

MANUAL

VLX-F231-B25 VLX Interface Module EtherNet/IP

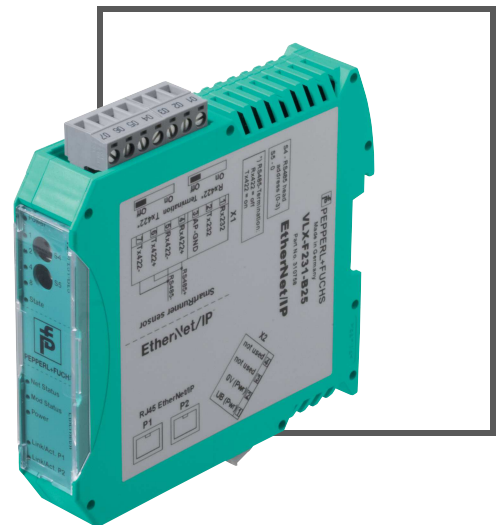

EtherNet/IP™

With regard to the supply of products, the current issue of the following document is applicable: The General Terms of Delivery for Products and Services of the Electrical Industry, published by the Central Association of the Electrical Industry (Zentralverband Elektrotechnik und Elektroindustrie (ZVEI) e.V.) in its most recent version as well as the supplementary clause: "Expanded reservation of proprietorship"

1	Introduction.....	4
1.1	Content of this Document	4
1.2	Target Group, Personnel.....	4
1.3	Symbols Used	4
2	Product Description	6
2.1	Use and Application.....	6
2.2	Dimensions.....	6
2.3	Design of the Device.....	7
3	Installation.....	10
3.1	Mounting.....	10
3.2	Electrical Connection	11
3.3	Dismounting	13
4	Commissioning.....	14
4.1	Introduction	14
4.2	Connecting the Sensor.....	14
4.3	Connection to the Network	15
4.4	IP Address	15
4.5	Configuration.....	18
4.6	Data Format for Modules	22

1 Introduction

1.1 Content of this Document

This document contains information required to use the product in the relevant phases of the product life cycle. This may include information on the following:

- Product identification
- Delivery, transport, and storage
- Mounting and installation
- Commissioning and operation
- Maintenance and repair
- Troubleshooting
- Dismounting
- Disposal



Note!

For full information on the product, refer to the further documentation on the Internet at www.pepperl-fuchs.com.

The documentation comprises the following parts:

- This document
- Datasheet

In addition, the documentation may comprise the following parts, if applicable:

- EU-type examination certificate
- EU declaration of conformity
- Attestation of conformity
- Certificates
- Control drawings
- Instruction manual
- Other documents

1.2 Target Group, Personnel

Responsibility for planning, assembly, commissioning, operation, maintenance, and dismounting lies with the plant operator.

Only appropriately trained and qualified personnel may carry out mounting, installation, commissioning, operation, maintenance, and dismounting of the product. The personnel must have read and understood the instruction manual and the further documentation.

Prior to using the product make yourself familiar with it. Read the document carefully.

1.3 Symbols Used

This document contains symbols for the identification of warning messages and of informative messages.

Warning Messages

You will find warning messages, whenever dangers may arise from your actions. It is mandatory that you observe these warning messages for your personal safety and in order to avoid property damage.

Depending on the risk level, the warning messages are displayed in descending order as follows:



Danger!

This symbol indicates an imminent danger.

Non-observance will result in personal injury or death.



Warning!

This symbol indicates a possible fault or danger.

Non-observance may cause personal injury or serious property damage.



Caution!

This symbol indicates a possible fault.

Non-observance could interrupt the device and any connected systems and plants, or result in their complete failure.

Informative Symbols



Note!

This symbol brings important information to your attention.



Action

This symbol indicates a paragraph with instructions. You are prompted to perform an action or a sequence of actions.

2 Product Description

2.1 Use and Application

The **VLX-F231-B25** interface module is used as an interface between the **SmartRunner** light section sensor (hereinafter referred to as "sensor") and the EtherNet/IP control panel. The interface module transfers process data between the connected sensors, and the higher-level EtherNet/IP control panel via an RS-485 interface.

You can connect up to four sensors to the interface module. If you connect multiple sensors, they must have different addresses.

The interface module has two EtherNet/IP ports. One port can be used as an outgoing EtherNet/IP port, for example.

2.2 Dimensions

The interface module housing has the following dimensions.

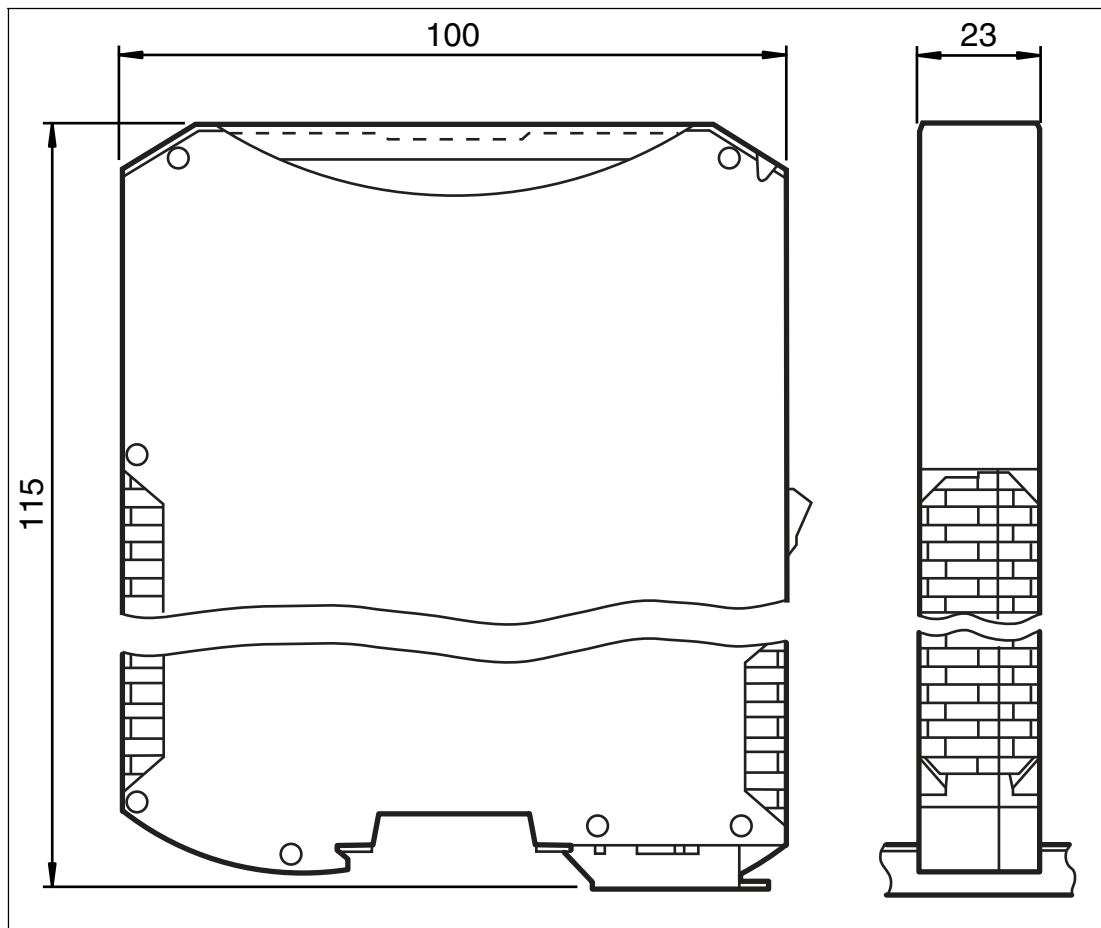

Figure 2.1 Dimensions

2.3 Design of the Device
Device Components

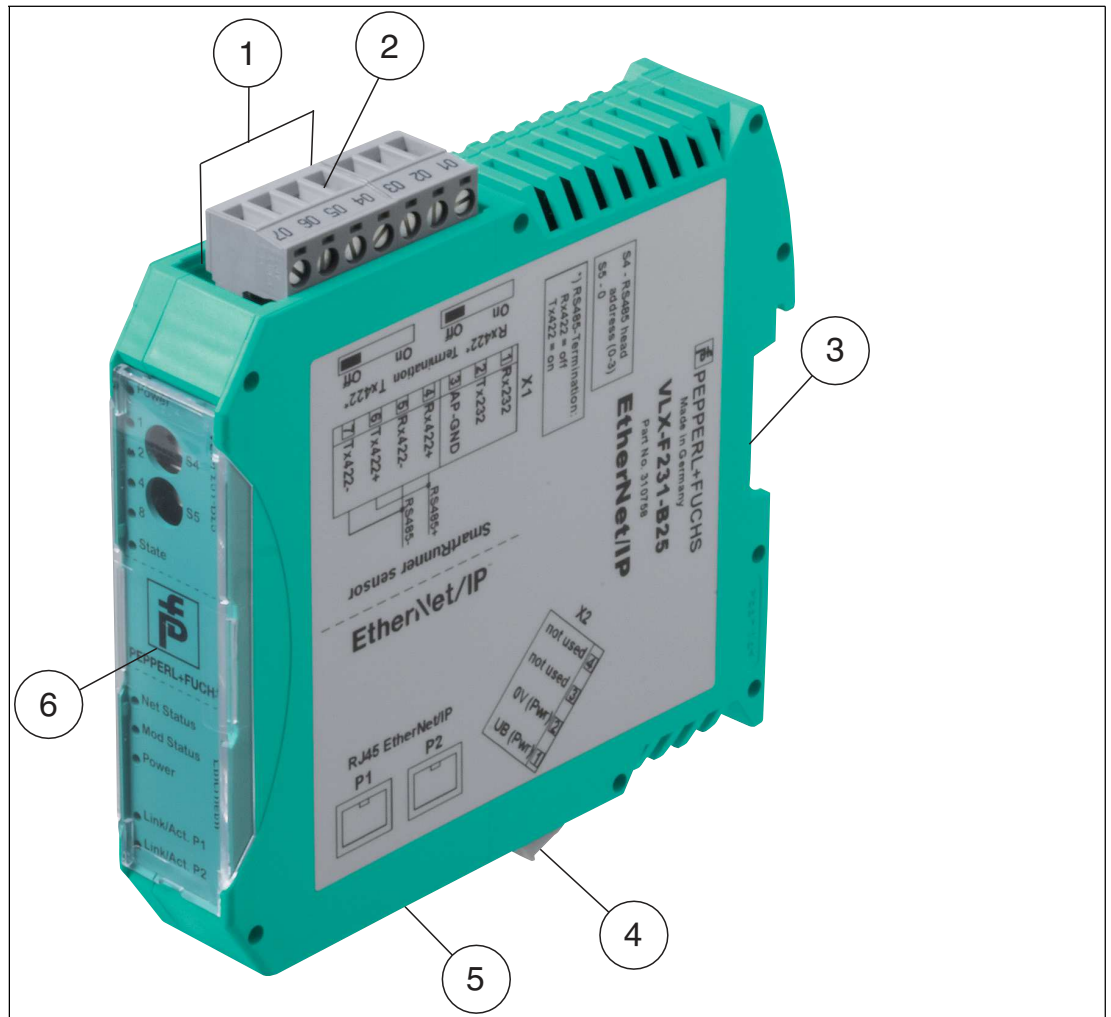

Figure 2.2 Interface module overview

- 1 RS-485 bus terminator sliding switch (behind the terminal block)
- 2 X1: RS-485 interface
- 3 Mounting bracket
- 4 X2: Connection for power supply
- 5 X3: EtherNet/IP communication interface
- 6 Front panel with rotary coding switches and indicator lights

Front Panel

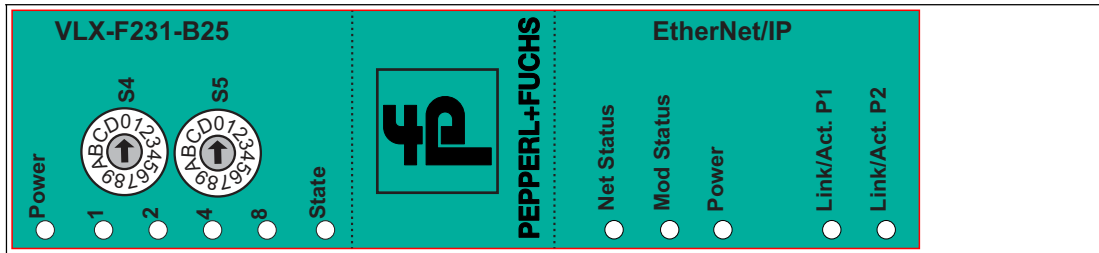

Figure 2.3 Front panel overview

Sensor (VLX-F231-B25)

Power

The "Power" LED lights up green: Power supply is present.

State

The "State" LED lights up green: Data is being exchanged with the sensor. The four "Error No/Select ID" LEDs are used to display the number of the currently polled sensor.

Error No/Select ID				Sensor address
8	4	2	1	
0	0	0	1	0
0	0	1	0	1
0	1	0	0	2
1	0	0	0	3

The "State" LED is red: The interface module has detected an error or a warning. The interface module displays the binary coded error and/or warning number via the "Error No/Select ID" LEDs.

Error (No. 1...5):

Switch the interface module off and back on. If the error occurs again, the module must be replaced.

Warning (No. 6...15):

The warning provides information. The interface module displays the warning for one minute and then resets automatically.

LED Error No/Select ID				Error number	Error description
LED8	LED4	LED2	LED1		
0	0	0	0	0	Reserved
0	0	0	1	1	Hardware error
0	0	1	0	2	EEPROM error
0	0	1	1	3	Internal memory error
0	1	0	0	4	Fieldbus hardware error or incorrect fieldbus ID
0	1	0	1	5	Script error
0	1	1	0	6	Reserved
0	1	1	1	7	Sensor communication, RS send buffer overflow
1	0	0	0	8	Sensor communication, RS receive buffer overflow
1	0	0	1	9	Sensor communication, RS timeout

2019-03

LED Error No/Select ID				Error number	Error description
LED8	LED4	LED2	LED1		
1	0	1	0	10	General fieldbus error
1	0	1	1	11	Parity error or frame check error
1	1	0	0	12	Reserved
1	1	0	1	13	Fieldbus configuration error
1	1	1	0	14	Fieldbus data buffer overflow
1	1	1	1	15	Reserved

Table 2.1 Meaning of the error codes (display via the four "Error No/Select ID" LEDs when the "State" LED lights up red and thus indicates an error or a warning)

Rotary coding switches S4 and S5

The two switches are used to control the operating modes. Ensure that the two switches are at **position 0** to enable the data exchange mode.

EtherNet/IP

Net Status

"Net Status" LED	Meaning (network status)
Lights up green	Connection present, data exchange is active
Flashes green	Waiting for a connection to be established
Flashes red/green	Self test
Lights up red	IP address assigned twice
Flashes red	Connection timed out

Mod Status

"Mod Status" LED	Meaning (module status)
Lights up green	Data exchange active
Flashes green	Standby/module waiting for connection
Flashes red/green	Self test
Lights up red	Serious module error
Flashes red	Module error

Power

The "Power" LED lights up green: The LED is connected directly to the electrically isolated supply voltage of the EtherNet/IP side.

Link/Act. P1

This LED is controlled directly by the EtherNet/IP controller. It lights up when the gateway identifies an operational network on Port 1 (X3 P1) (link pulses received) and flickers when there is data traffic on the network.

Link/Act. P2

This LED is controlled directly by the EtherNet/IP controller. It lights up when the gateway identifies an operational network on Port 2 (X3 P2) (link pulses received) and flickers when there is data traffic on the network.

3 Installation

3.1 Mounting



Mounting the Modules

The module is fastened to a DIN mounting rail with a width of 35 mm using a snap-on fixing method.

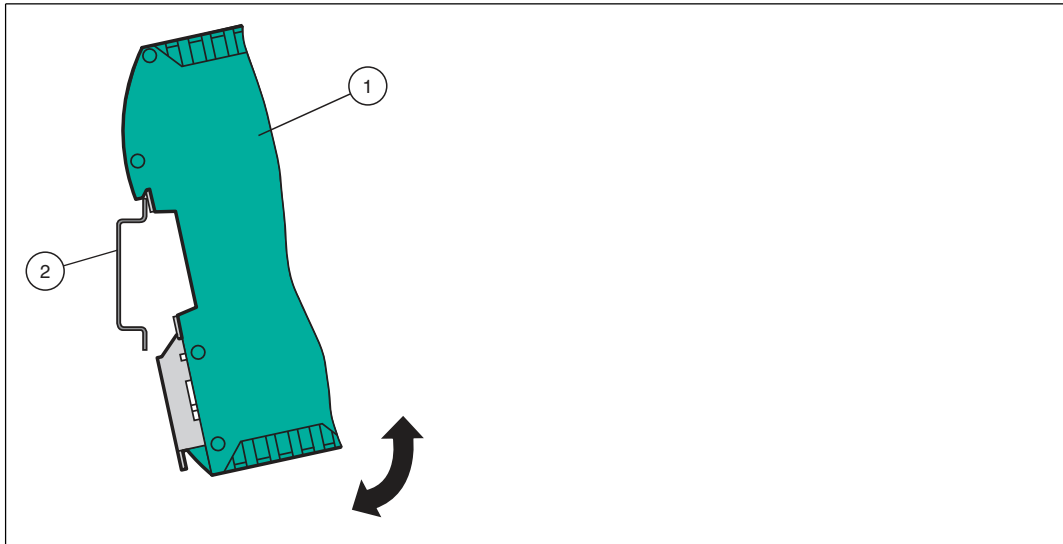

Figure 3.1 Mounting

1. Hook the module (1) onto the DIN mounting rail (2) from above and press it down until it snaps into place.

↳ The module is mounted.



Note!

Heat Dissipation

You may place other modules to the left and right of the module. Above and below the modules, there must be at least 5 cm of free space for heat dissipation.

2. You must connect the DIN mounting rail to the switch cabinet's equipotential busbar. The connection wire must have a cross section of at least 10 mm².



Note!

Vertical Installation

You can also install the DIN mounting rail vertically, so that the modules can be rotated by 90° for mounting.

3.2 Electrical Connection



Danger!

Device damage due to incorrect installation

Incorrect installation of cables and connection lines can endanger the function and the electrical safety of the device.

- Note the permissible core cross section of the conductor.
- If you are using stranded conductors, crimp the stranded conductors with wire end ferrules.
- Make sure that the insulation on the conductors extends all the way to the terminal.
- Observe the tightening torque for the screws on the terminal. The tightening torque is 0.5 Nm.
- Using an inappropriate tool may damage the screw heads. Use a slot-head screwdriver of size 3.5 x 0.5.
- Connecting an alternating current can damage the device or cause the device to malfunction. Connect the device to direct current (DC).

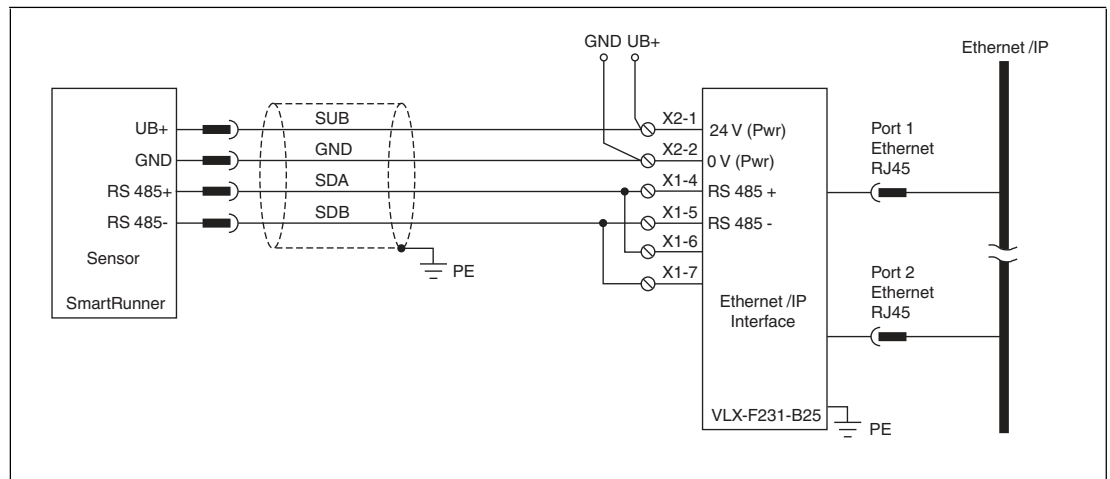

Figure 3.2 Electrical connection

Plug X1 is located on the top side of the interface module, and plug X2 is located on the underside.

Connection Technology

You must/may use the following connection technology when wiring the module:

- Standard screw/plug connection (supply + RS)
- 8-pin RJ45 connection (EtherNet/IP connection)

When using standard screw terminals, one cable per connection point can be clamped. To tighten the screws, use a screwdriver with a blade width of 3.5 mm.

Permissible cable cross section:

- Flexible cable with wire end ferrule: 1 x 0.25 ... 1.5 mm²
- Solid cable: 1 x 0.25 ... 1.5 mm²

The plug-in terminal strip combines a standard screw connection and a plug connector. The plug connector is coded and therefore cannot be plugged in incorrectly.



Connecting the Power Supply

Connect the operating voltage (10 VDC ... 30 VDC) to terminals 1 and 2 of the 4-pin plug X2 on the interface module. In addition, note the label on the module.

↳ The "Power" LED lights up green.

Terminal		Description
1	UB (Pwr)	Operating voltage interface module/ operating voltage sensor
2	0 V (Pwr)	Ground interface module/ground sensor
3	not used	Is not used
4	not used	Is not used

Table 3.1 Terminal X2

Equipotential Bonding Connection

The connection to equipotential bonding occurs automatically when attaching to the DIN mounting rail.



EtherNet/IP Communication Interface

This interface can be found on the interface module in the form of two 8-pin RJ45 sockets on the bottom of the housing.

Insert the EtherNet/IP connector into one of the RJ45 socket(s) with the inscription "In" (cable from master) or "Out" (further cable to the next EtherNet/IP slave).



Note!

Ensure that the cable length to the neighboring EtherNet/IP participants is at least 0.6 m.



Preparing for Operation on the RS-485 Interface

For operation on an RS-485 interface, the terminals on connector X1 must be connected as follows:

1. Connect terminal 4 "Rx 422+" to terminal 6 "Tx 422+."
2. Connect terminal 5 "Rx 422-" to terminal 7 "Tx 422-."

Terminal		Description
4	Rx 422+	Data line RS-485+ to sensor
5	Rx 422-	Data line RS-485- to sensor
6	Tx 422+	Connect terminal 6 "Tx 422+" to terminal 4 "Rx 422+"
7	Tx 422-	Connect terminal 7 "Tx 422-" to terminal 5 "Rx 422-"

Table 3.2 Terminal X1



Note!
RS-485 Bus Termination

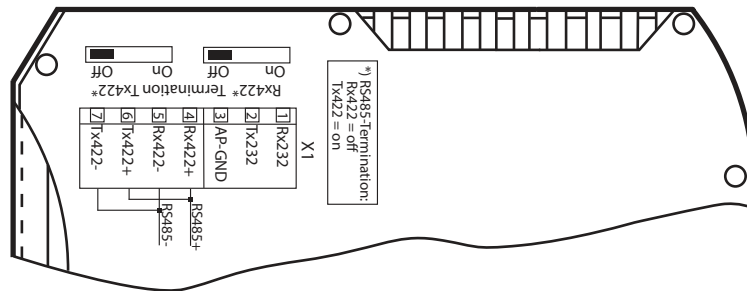

If the interface module is operated as the first or last physical device in an RS-485 bus, there must be a bus termination on this module. To do this, set the "Rx 422 Termination" slide switch to "Off" and the "Tx 422 Termination" slide switch to "On." This activates the RS-485 terminator (150 Ω) built into the interface module.

If you connect only one sensor to the interface module, you must always activate the RS-485 terminator.

3.3

Dismounting



Dismounting the modules

Use a suitable slot-head screwdriver for dismounting the module.

1. Disconnect all the supply and signal lines.

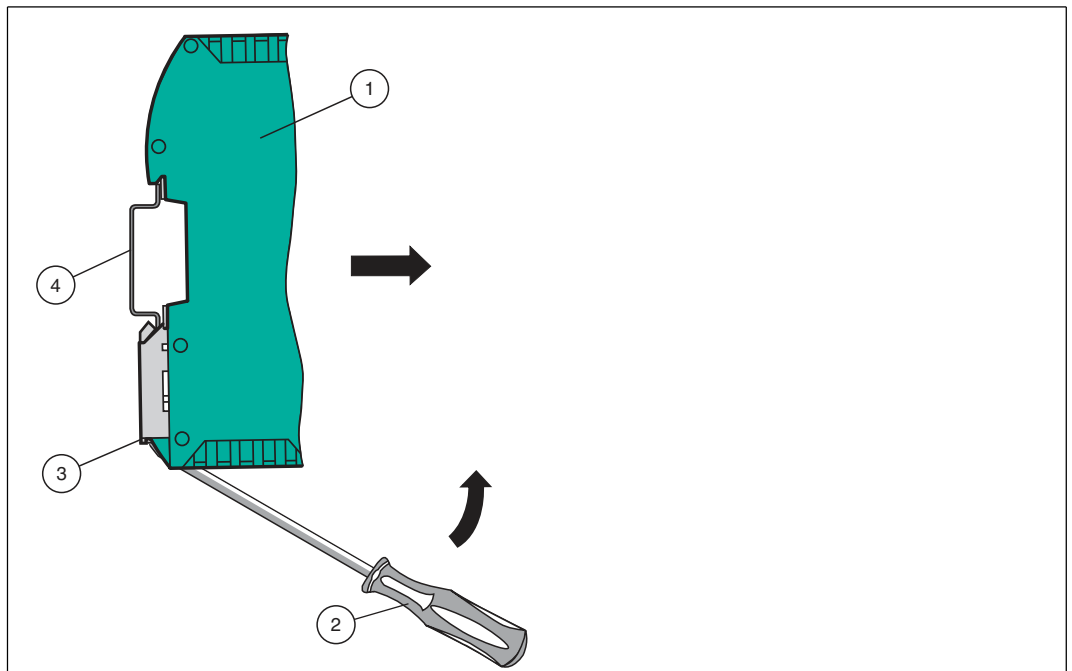

Figure 3.3 Dismounting

2. Insert the screwdriver (2) into the groove of the mounting bracket (3).
3. Press the screwdriver (2) in the specified direction until the lock on the DIN mounting rail (4) opens, see figure.
4. Then press the module (1) upwards and lift it out of the DIN mounting rail.

4 Commissioning

4.1 Introduction



Warning!

Danger to life due to defective work

Errors during installation and commissioning can cause life-threatening injuries and significant property damage.

- Installation and commissioning must only be carried out by trained personnel in accordance with safety regulations.

Components

To commission the module, you will require the following components:

- VLX-F231-B25 interface module
- EDS file (the EDS file can be obtained free of charge from our website www.pepperl-fuchs.com).
- Cordset from the interface module to the sensor
- Connector for the EtherNet/IP connection to the interface module
- Ethernet cable
- 10 VDC ... 30 VDC power supply



Downloading the EDS File

You will need an EDS file to operate the module described in this manual. The EDS file must be imported into the corresponding configuration tool before commissioning the module. The EDS file can be downloaded from our website: www.pepperl-fuchs.com. Simply enter the product name or item number in the product/keyword field and click the "Search" icon.

1. To access the product detail page for the device, go to <http://www.pepperl-fuchs.com> and enter information about the device (e.g., the product description or the item number) into the search function.
2. Select your product from the list of search results. Click on the information you require in the product information list, e.g., **Software**.



↳ A list of all available downloads is displayed.

4.2 Connecting the Sensor

If you connect several sensors to one interface module, the sensors must have different addresses. The different addresses will allow the programmable logic controller to allocate the data to the right sensors. If you connect only one sensor to an interface module, this sensor always receives the address 0. You can connect up to four sensors to an interface module via an RS-485 cable. Each sensor is supplied with the default address of 0. Details of how to change the address of the sensor can be found in the instruction manual for the sensor.

Sensor connection pin	Interface module terminal
1	X2-1
2	X1-4
4	X1-5
3	X2-2

Table 4.1 Connecting the sensor/sensors

Setting the Number of Connected Sensors

Set the number of connected sensors in the hardware project settings.

4.3 Connection to the Network

The connection to EtherNet/IP is made via the two **RJ 45 EtherNet/IP P1 and P2** sockets on the underside of the interface module. The front socket is labeled **P1** and the rear socket is labeled **P2**. Connect the device to the EtherNet/IP network at the interface with the label "P1" (cable from master) or "P2" (further cable to the next slave).

Pinout P1 and P2

Terminal		Designation
1	TD+	Transmission line +
2	TD-	Transmission line -
3	RD+	Receive line +
4	n.c.	Not connected
5	n.c.	Not connected
6	RD-	Receive line -
7	n.c.	Not connected
8	n.c.	Not connected

Table 4.2 Terminals of the 8-pin "RJ45 EtherNet/IP" sockets



Note!

The cable to the surrounding Ethernet devices must be at least 0.6 m long.



Connecting the Device to the Controller

Plug the Ethernet connector into the RJ45 socket. Use a Cat. 5 data cable.



Setting Data Exchange Mode

Set rotary switch "S5" to position 0. The rotary switch "S4" is set in accordance with the connected sensors.

4.4 IP Address



Setting the IP Address

The VLX-F231-B25 interface module is delivered in DHCP mode and waits for an address to be assigned by the control panel.

The following section describes how to assign an address, using the BOOT/DHCP server software from Rockwell Automation as an example.

1. Connect the sensor to the DHCP server.
2. Start the BOOT/DHCP server software.
3. Enter the following data into the **Network Settings** input mask:
 - Subnet Mask: 255.255.255.0
 - Gateway: 192.168.1.1
 - The remaining fields do not need to be filled in

Figure 4.1 Network Settings

4. Switch on the supply voltage to the sensor.
 - ↳ The sensor cyclically executes DHCP requests. This enters the MAC address of the sensor to the list in the **Discover History** field.

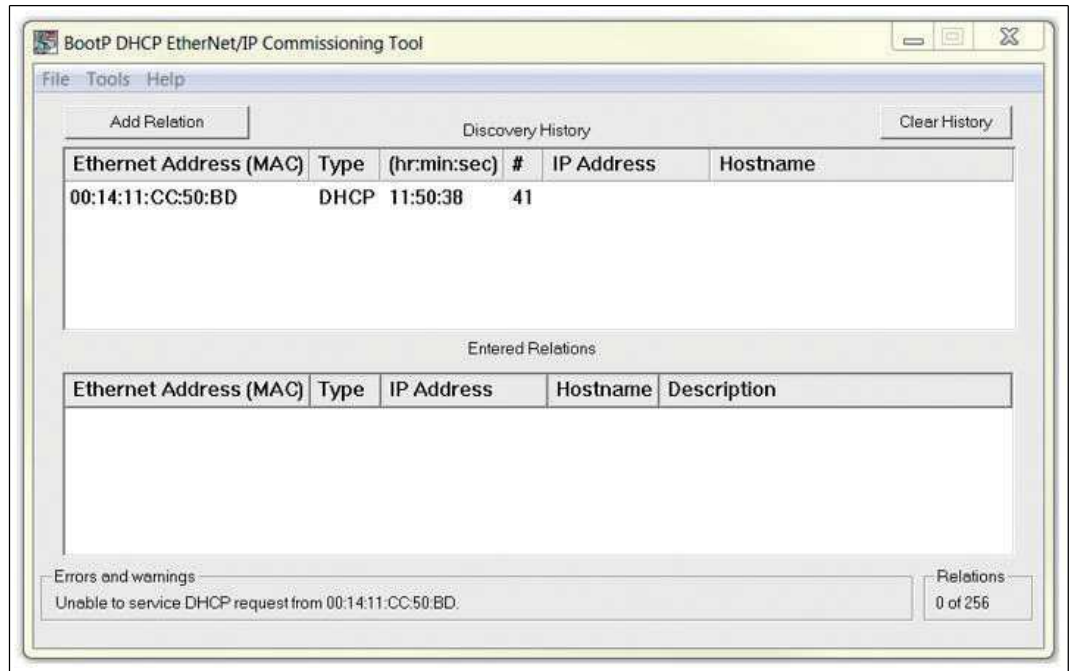

Figure 4.2 Discovery History

5. Enter the corresponding IP address in the **New Entry** input mask.
 - ↳ The software automatically fills in the MAC address of the sensor. The "Hostname" function is not supported. You can enter text under "Description."

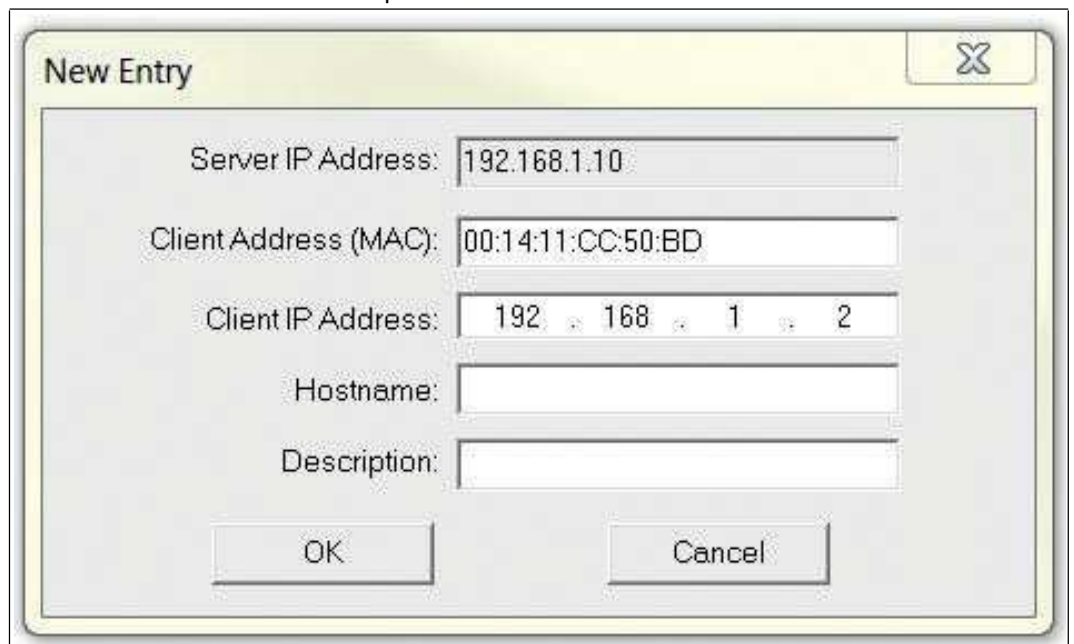

Figure 4.3 New Entry

6. Confirm the address data that has been entered by pressing the **OK** button.
 - ↳ The IP address is assigned to the sensor at the next DHCP request. The new address data will be displayed in the **Entered Relations** field.

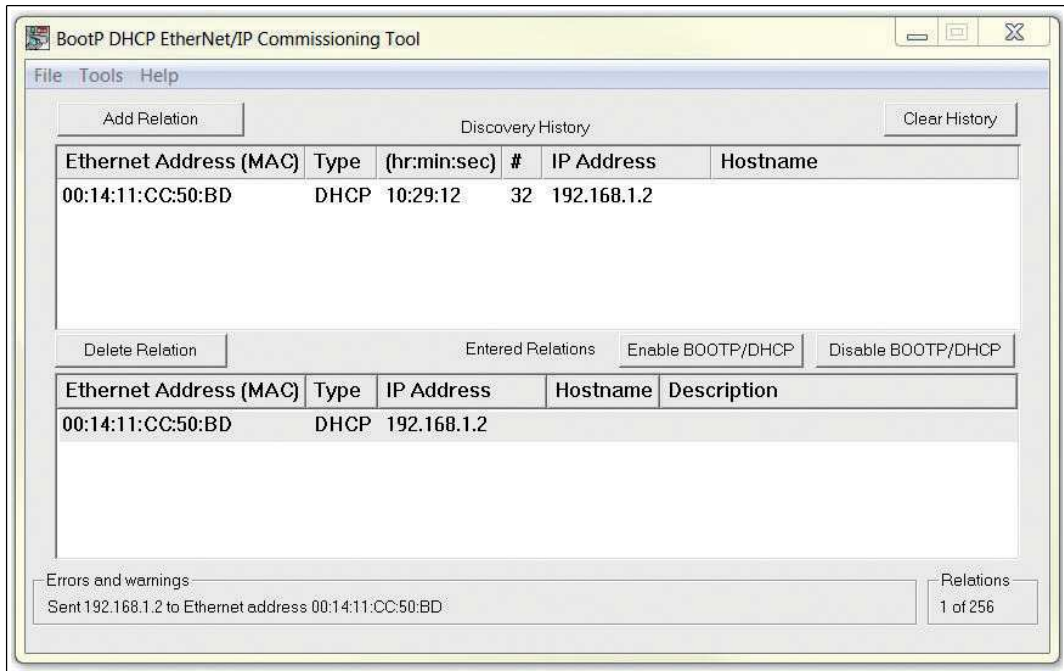

Figure 4.4 Entered Relations

7. Click on the **Disable BOOTP/DHCP** button (1) in the "Entered Relations" field.

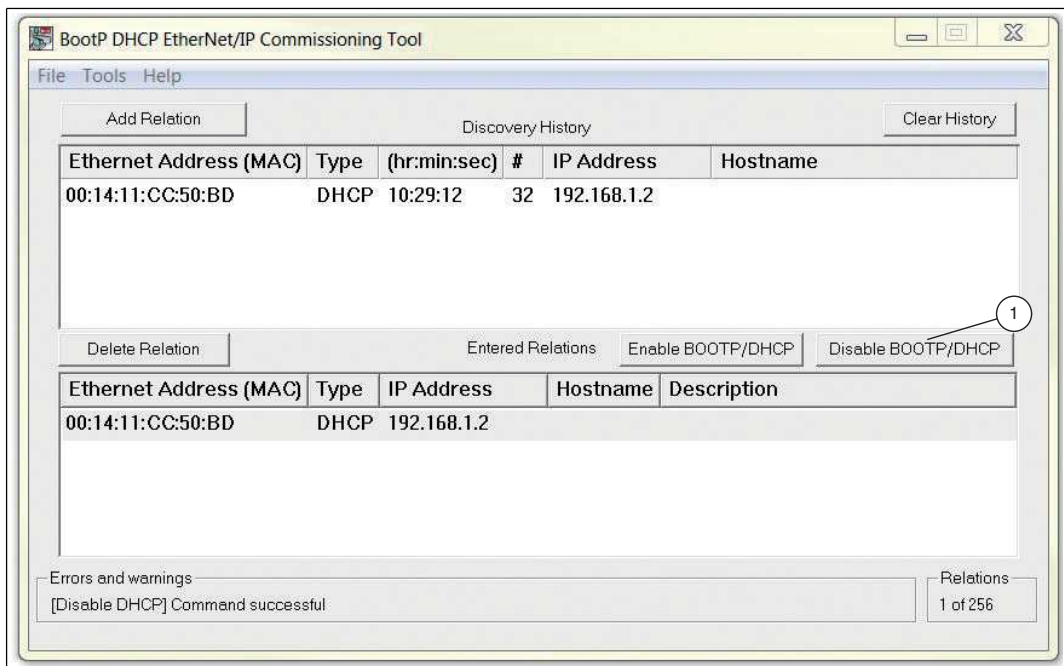

Figure 4.5 Disable BOOTP/DHCP

↳ As a result, the assigned IP address is stored permanently in the sensor.

4.5 Configuration



Caution!

Malfunction due to incorrectly configured devices

Incorrectly configured devices can cause the system to malfunction.

- Only put devices into operation after they have been configured correctly.



Configuration Example

The configuration and commissioning procedure for modules that is described on the following pages is based on the RSLogix5000 software from Rockwell Automation. When using a control system from a different provider, please refer to the corresponding documentation.

1. Install the EDS files for the modules in "RSLogix5000" using the EDS hardware installation tool in the "Tools" menu.
2. Select the right controller.
3. Select the "New Module" menu item. The following selection window opens:

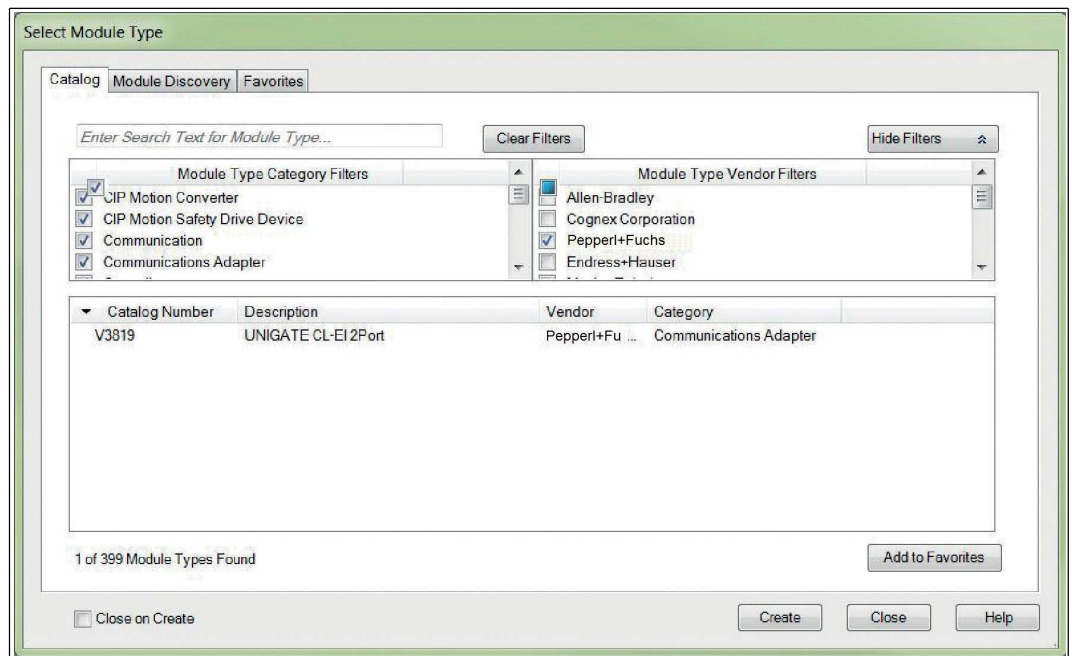

Figure 4.6 Select Module Type

4. On the right-hand side of the window, select the "Pepperl+Fuchs" option in the **Module Type Vendor Filters** list to display the installed VLX-F231-B25 interface module as a "UNIGATE CL-EI2Port."
5. Select the module you want to add and click the **Create** button.

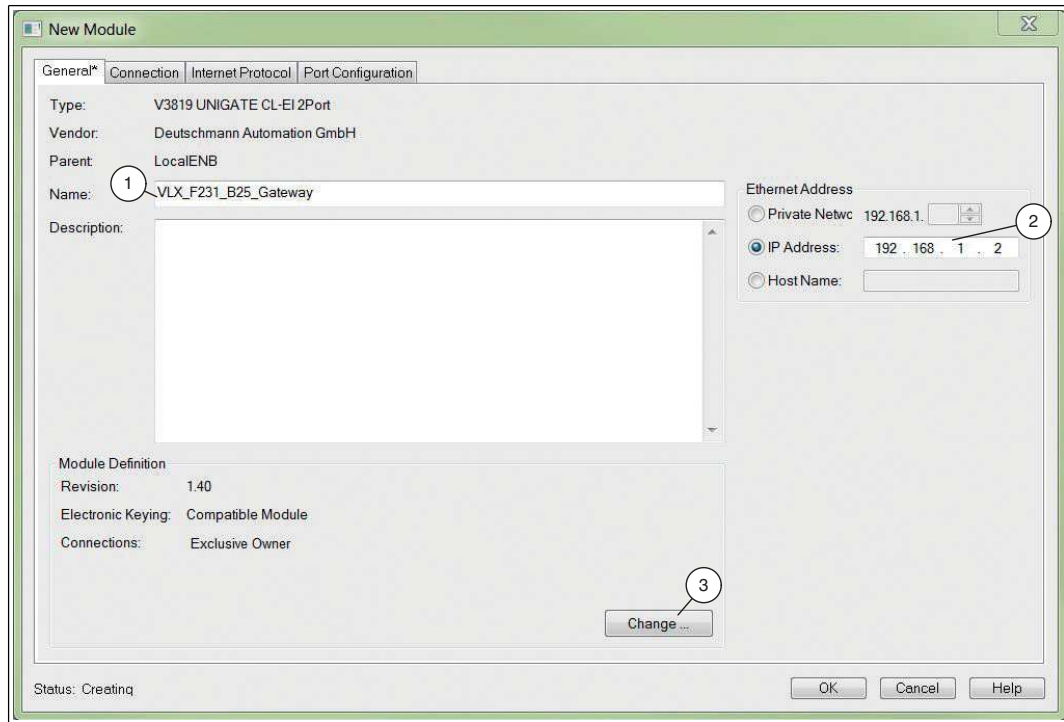

Figure 4.7 New Module

6. Enter a name for the interface module in the **Name** input field (1) and enter the right IP address in the **IP Address** input field (2). The name "VLX_F231_B25_Gateway" and IP address "192.168.1.2" have been used in this example.



Note!

The VLX-F231-B25 interface module can accommodate up to four sensors. There is a corresponding EDS file for the number of connected sensors.

Values for "input size" and "output size"

1 SmartRunner	INPUT	24 bytes	SINT
	OUTPUT	6 bytes	SINT
2 SmartRunners	INPUT	48 bytes	SINT
	OUTPUT	12 bytes	SINT
3 SmartRunners	INPUT	72 bytes	SINT
	OUTPUT	18 bytes	SINT
4 SmartRunners	INPUT	96 bytes	SINT
	OUTPUT	24 bytes	SINT

7. Confirm the module settings by clicking the **Change** button (1).

↳ The **Module Definition** window opens. Adjust the settings for the module revision, electronic keying, and connection type, and confirm your selection by clicking the **OK** button.

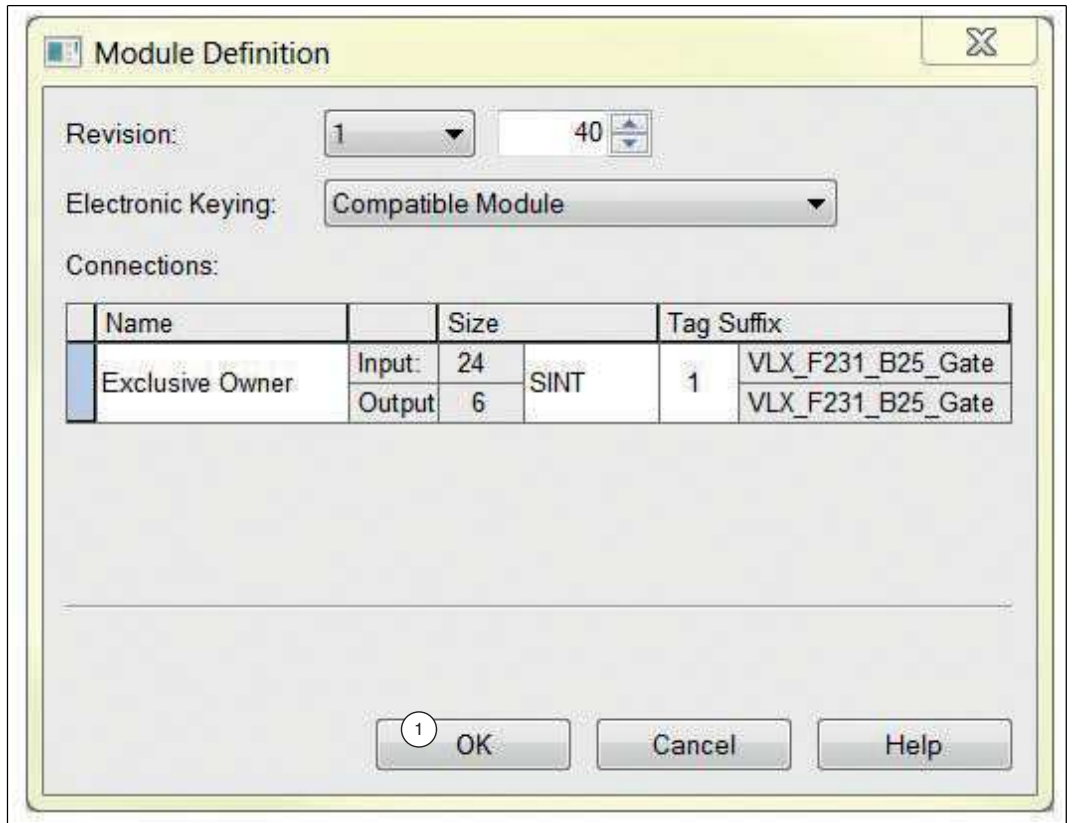

Figure 4.8 Module Definition

8. On the **Connection** tab, select the type of connection. This determines which process and diagnostic data the interface module provides.

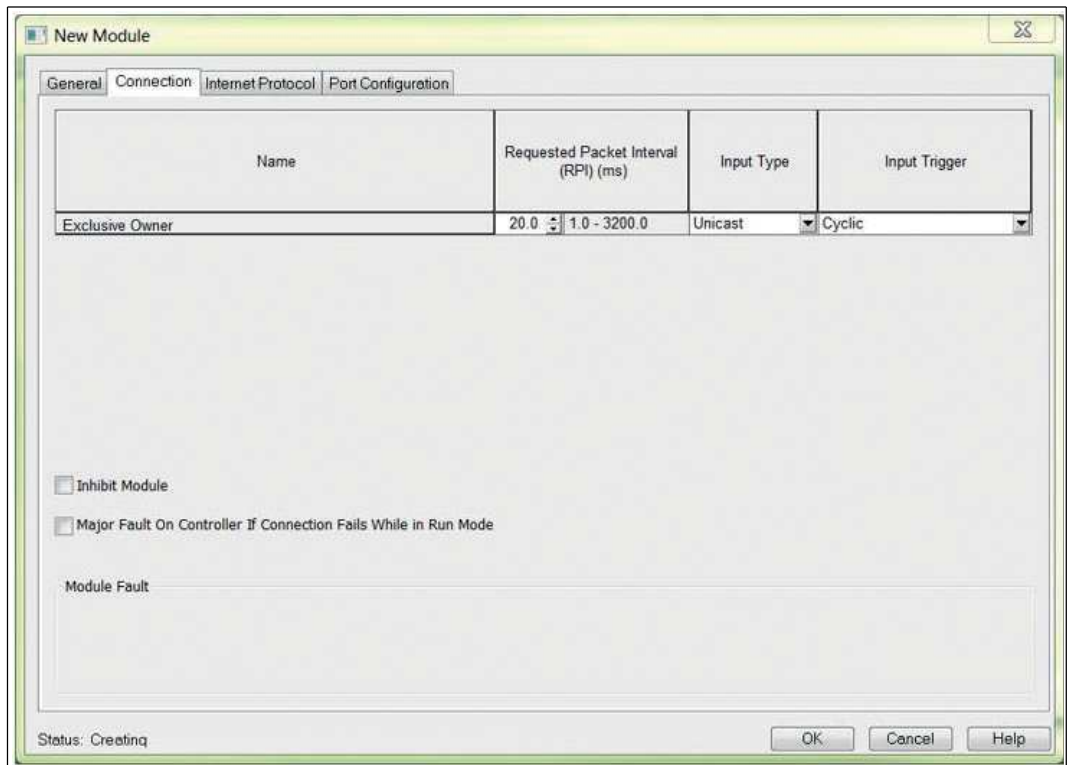

Figure 4.9 Connection

↳ In the **Connection** selection window, you can see the selected connection type and also set the "Requested Packet Interval (RPI)" and "Input Type."

Software Tool for RSLogix 5000/Studio 5000

A software tool is available to allow you to configure the interface module. This can be downloaded from our website: www.pepperl-fuchs.com. Simply enter the product name or item number in the Product/Keyword field and click the "Search" icon. Select your product from the list of search results. Click on the information you require in the product information list, e.g., Software. A list of all available downloads is displayed.

The following image shows the layout of the software tool and the variables to be parameterized.

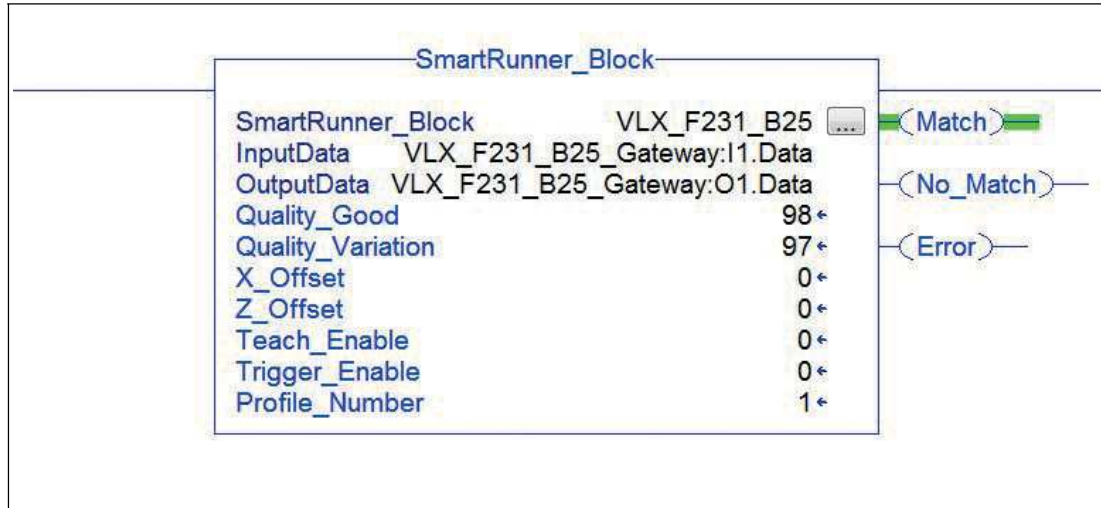

Figure 4.10 SmartRunner_Block

Name	Description
Quality_Good	Quality of the current profile (0 = no profile found, 100 = perfect match)
Quality_Variation	Quality check two
X_Offset	X-deviation of the current profile from the saved profile
Z_Offset	Z-deviation of the current profile from the saved profile
Teach_Enable	Teach trigger: 1 = Teach enabled, 0 = Teach deactivated
Trigger_Enable	Manual trigger: 1 = trigger enabled, 0 = trigger deactivated
Profile_Number	Profile number 1 ... 32
Match	Good: The profile corresponds to the saved profile
No_Match	Bad: The profile does not correspond to the saved profile
Error	System or evaluation error

4.6 Data Format for Modules

Output parameters

Byte	Bit 7	Bit 6	Bit 5	Bit 4	Bit 3	Bit 2	Bit 1	Bit 0
Byte 0 - Reserved	0	0	0	0	0	0	0	0
Byte 1 - Trigger	0	0	0	0	0	0	0	1
Byte 2 - Reserved	0	0	0	0	0	0	0	0
Byte 3 - Teach	0	0	0	0	0	0	0	1
Byte 4 - Reserved	0	0	0	0	0	0	0	0
Byte 5 - Choose profile ¹	0	0	x	x	x	x	x	x

1. Only for the VLM350-F280-R4-1001 and VLM350-F280-R4-1101

Legend

x	1 ... 32	Profile number
	0	Not defined
	> 32	Not defined

Trigger

After changing *bit 0* from **0 to 1**, a "**Trigger**" is activated. This means that the sensor triggers an image capture process. In order to run an additional "**Trigger**", **bit 0** must be reset.

Teach

After changing *bit 0* from **0 to 1**, a "**Teach-In**" is triggered. This means that the sensor initiates the teach-in process. A trigger must then be transmitted. In order to run the "**Teach**" process again, **bit 0** must be reset.

Input parameters



Note!

The two protocols "Result Protocol" and "Teach Result Protocol" are connected. The two protocols cannot be run at the same time. Only one of the two protocols can be run at a time.

Result Protocol

Result Data provides the measurement status and result as a response.

Byte	Bit 7	Bit 6	Bit 5	Bit 4	Bit 3	Bit 2	Bit 1	Bit 0
Byte 1 - Status	0	-	Addr 1	Addr 0	Event	WRN	No Match	ERR
Byte 2 - Result	0	R6	R5	R4	R3	R2	R1	R0
Byte 3 - Counter	0	C06	C05	C04	C03	C02	C01	C00
Byte 4 - Quality	0	Q06	Q05	Q04	Q03	Q02	Q01	Q00
Byte 5 - Quality	0	Q16	Q15	Q14	Q13	Q12	Q11	Q10
Byte 6 - Quality	0	Q26	Q25	Q24	Q23	Q22	Q21	Q20
Byte 7 - PosX	0	PosX13	PosX12	PosX11	PosX10	PosX09	PosX08	PosX07
Byte 8 - PosX	0	PosX06	PosX05	PosX04	PosX03	PosX02	PosX01	PosX00
Byte 9 - PosZ	0	PosZ13	PosZ12	PosZ11	PosZ10	PosZ09	PosZ08	PosZ07
Byte 10 - PosZ	0	PosZ06	PosZ05	PosZ04	PosZ03	PosZ02	PosZ01	PosZ00
Byte 11 - Checksum	0	xor	xor	xor	xor	xor	xor	xor
Byte 12	0	0	0	0	0	0	0	0
Byte 13	0	0	0	0	0	0	0	0
Byte 14	0	0	0	0	0	0	0	0
Byte 15	0	0	0	0	0	0	0	0
Byte 16	0	0	0	0	0	0	0	0

Legend

Status	Addr	Device address
	Event	Event occurred (future) Currently read as 0
	WRN	Unused
	No Match	Profile does not match the saved profile
	ERR	System error or evaluation error
Result	R0 ... R6	Profile number 1 ... 32 0x00 = no object found
Quality	Q00 ... Q26	Quality of the current profile (0 = no profile found, 100 = perfect match) Quality: Quality Good Quality2: Quality Variation Quality3: Quality Outliers
Counter		Increments for each evaluation, is restarted at 0x3F
Position Data ¹	PosX16 ... PosX00	X-deviation of current profile from saved profile
	PosZ16 ... PosZ00	Z-deviation of current profile from saved profile

1. Only for the VLM350-F280-R4-1001 and VLM350-F280-R4-1101

Teach Result Protocol

Teach Result Data returns the status and result of the teach-in process as a response.

Byte	Bit 7	Bit 6	Bit 5	Bit 4	Bit 3	Bit 2	Bit 1	Bit 0
Byte 17 - Status	0	-	Addr 1	Addr 0	Event	WRN	0	ERR
Byte 18 - Result	0	0	0	0	0	0	0	0
Byte 19 - Counter	0	C06	C05	C04	C03	C02	C01	C00
Byte 20 - Quality A	0	QA6	QA5	QA4	QA3	QA2	QA1	QA0
Byte 21 - Quality B	0	QB6	QB5	QB4	QB3	QB2	QB1	QB0
Byte 22 - Quality C	0	QC6	QC5	QC4	QC3	QC2	QC1	QC0
Byte 23 - Quality D	0	QD6	QD5	QD4	QD3	QD2	QD1	QD0
Byte 24 - Checksum	0	xor	xor	xor	xor	xor	xor	xor

Legend

Status	Addr	Device address
	Event	Event has occurred - for future use, currently read as 0
	WRN	Unused
	ERR	System error or evaluation error
Result	R0	For extended protocol Always 0
Counter	C00 ... C06	Increments with each teach-in
Quality A		The quality of the current teach-in 0 = teach-in not possible 100 = perfect teach-in
Quality B-D		Unused

FACTORY AUTOMATION – SENSING YOUR NEEDS



Worldwide Headquarters

Pepperl+Fuchs GmbH
68307 Mannheim · Germany
Tel. +49 621 776-0
E-mail: info@de.pepperl-fuchs.com

USA Headquarters

Pepperl+Fuchs Inc.
Twinsburg, Ohio 44087 · USA
Tel. +1 330 4253555
E-mail: sales@us.pepperl-fuchs.com

Asia Pacific Headquarters

Pepperl+Fuchs Pte Ltd.
Company Registration No. 199003130E
Singapore 139942
Tel. +65 67799091
E-mail: sales@sg.pepperl-fuchs.com

www.pepperl-fuchs.com

 **PEPPERL+FUCHS**
SENSING YOUR NEEDS