

Functional Safety
Remote I/O LB/FB Devices

Manual

SIL

IEC 61508/61511



CE

SIL 2



With regard to the supply of products, the current issue of the following document is applicable:
The General Terms of Delivery for Products and Services of the Electrical Industry, published by the Central Association of the Electrical Industry (Zentralverband Elektrotechnik und Elektroindustrie (ZVEI) e.V.) in its most recent version as well as the supplementary clause: "Expanded reservation of proprietorship"

Worldwide

Pepperl+Fuchs Group
Lilienthalstr. 200
68307 Mannheim
Germany
Phone: +49 621 776 - 0
E-mail: info@de.pepperl-fuchs.com

North American Headquarters

Pepperl+Fuchs Inc.
1600 Enterprise Parkway
Twinsburg, Ohio 44087
USA
Phone: +1 330 425-3555
E-mail: sales@us.pepperl-fuchs.com

Asia Headquarters

Pepperl+Fuchs Pte. Ltd.
P+F Building
18 Ayer Rajah Crescent
Singapore 139942
Phone: +65 6779-9091
E-mail: sales@sg.pepperl-fuchs.com
<https://www.pepperl-fuchs.com>

1	Introduction	5
1.1	Content of this Document	5
1.2	Safety Information	6
1.3	Symbols Used	7
2	Product Description	8
2.1	Function	8
2.2	Interfaces	9
2.3	Marking	9
2.4	Standards and Directives for Functional Safety	10
3	Planning	11
3.1	System Structure	11
3.2	Assumptions	12
3.3	Safety Function and Safe State	12
3.4	Characteristic Safety Values	14
3.5	Useful Lifetime	18
4	Mounting and Installation	19
4.1	Connection and Configuration of the Output Shutdown in the LB-System	19
4.2	Connection of the Output Shutdown in the FB-System	22
5	Operation	24
5.1	Proof Test	24
6	Maintenance and Repair	25
7	List of Abbreviations	26

1 Introduction

1.1 Content of this Document

This document contains information for usage of the device in functional safety-related applications. You need this information to use your product throughout the applicable stages of the product life cycle. These can include the following:

- Product identification
- Delivery, transport, and storage
- Mounting and installation
- Commissioning and operation
- Maintenance and repair
- Troubleshooting
- Dismounting
- Disposal

**Note**

This document does not substitute the instruction manual.

**Note**

For full information on the product, refer to the instruction manual and further documentation on the Internet at www.pepperl-fuchs.com.

**Note**

For specific device information such as the year of construction, scan the QR code on the device. As an alternative, enter the serial number in the serial number search at www.pepperl-fuchs.com.

The documentation consists of the following parts:

- Present document
- Instruction manual
- Manual
- Datasheet

Additionally, the following parts may belong to the documentation, if applicable:

- EU-type examination certificate
- EU declaration of conformity
- Attestation of conformity
- Certificates
- Control drawings
- FMEDA report
- Assessment report
- Additional documents

For more information about Pepperl+Fuchs products with functional safety, see www.pepperl-fuchs.com/sil.

1.2 Safety Information

Target Group, Personnel

Responsibility for planning, assembly, commissioning, operation, maintenance, and dismantling lies with the plant operator.

Only appropriately trained and qualified personnel may carry out mounting, installation, commissioning, operation, maintenance, and dismantling of the product. The personnel must have read and understood the instruction manual and the further documentation.

Intended Use

The device is only approved for appropriate and intended use. Ignoring these instructions will void any warranty and absolve the manufacturer from any liability.

The device is developed, manufactured and tested according to the relevant safety standards.

Use the device only

- for the application described
- with specified environmental conditions
- with devices that are suitable for this safety application

Improper Use

Protection of the personnel and the plant is not ensured if the device is not used according to its intended use.

1.3 Symbols Used

This document contains symbols for the identification of warning messages and of informative messages.

Warning Messages

You will find warning messages, whenever dangers may arise from your actions. It is mandatory that you observe these warning messages for your personal safety and in order to avoid property damage.

Depending on the risk level, the warning messages are displayed in descending order as follows:



Danger!

This symbol indicates an imminent danger.

Non-observance will result in personal injury or death.



Warning!

This symbol indicates a possible fault or danger.

Non-observance may cause personal injury or serious property damage.



Caution!

This symbol indicates a possible fault.

Non-observance could interrupt the device and any connected systems and plants, or result in their complete failure.

Informative Symbols



Note

This symbol brings important information to your attention.



Action

This symbol indicates a paragraph with instructions. You are prompted to perform an action or a sequence of actions.

2 Product Description

2.1 Function

The remote I/O devices are used in conjunction with a backplane that is integral part in the safety function. The devices act as interface between signals from the hazardous area and the non-hazardous area. The backplane also supplies the devices.

The safety function that can be implemented with the devices is influencing the outputs of the devices installed on the backplane. There is a control input on the backplane to which an output shutdown can be connected, e. g. an emergency switch. If the output shutdown is activated, the power supply for the safety circuit is interrupted and the outputs of all devices installed on the backplane are switched off.

All device outputs are galvanically isolated from the inputs. The outputs are not polarized and share a common reference potential of the power supply. The supply of the output shutdown and the outputs may be based on different potentials, as the signals are galvanically isolated from each other.

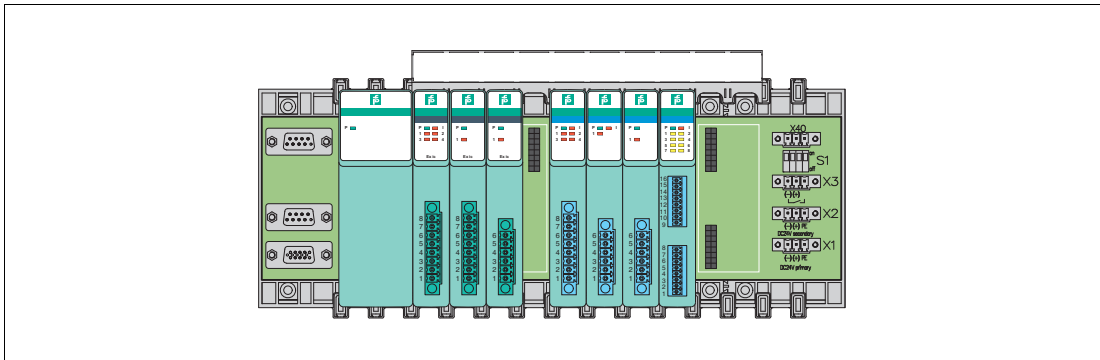

Figure 2.1 LB Remote I/O station with I/O devices mounted on a backplane

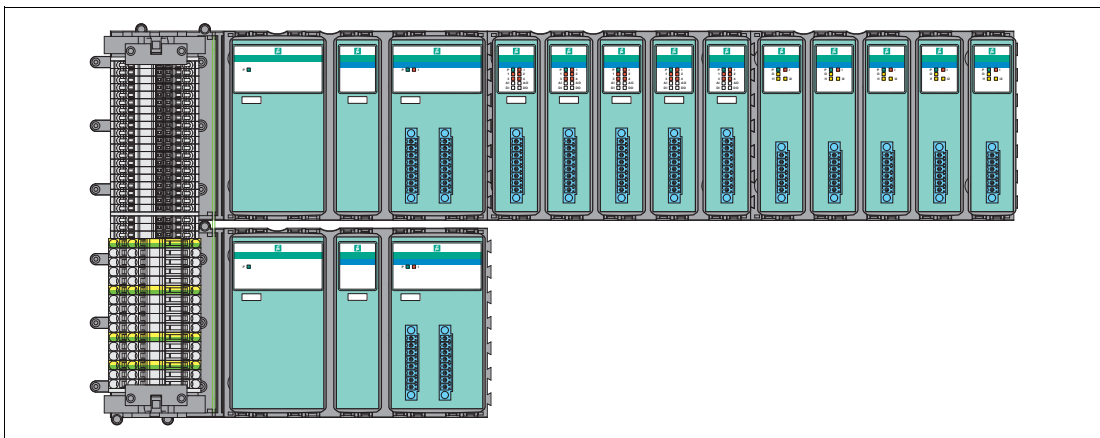

Figure 2.2 FB Remote I/O station with I/O devices mounted on a backplane

The safety function is implemented via a separate shutdown input and is independent of the bus communication. The separate shutdown input de-energizes outputs with a single action. In order to avoid unnecessary diagnostic messages the power supply to the module is not simply turned off but the output loop is interrupted. Modules with shutdown input can be combined with modules without shutdown input on the same backplane. Modules without shutdown input are consistently controlled by the bus. Modules with shutdown input are only controlled by the bus when the shutdown contact is closed. If the shutdown input is open, the modules are put into the safe state.



Note

See corresponding datasheets for further information.

2.2

Interfaces

The safety loop has the following interfaces:

- Safety relevant interfaces:
 - Outputs of the devices installed on the backplane
 - Control input for output shutdown connection, e. g. emergency switch
- Non-safety relevant interfaces: power supply output



Note

For corresponding connections see datasheet.

2.3

Marking

Pepperl+Fuchs Group Lilienthalstraße 200, 68307 Mannheim, Germany
Internet: www.pepperl-fuchs.com

Universal input/output (HART) LB7*04A, FB7*04A HART output isolator LB4*02*2, LB4*05*2, LB4*06*, FB4*02*2, FB4*05*2, FB4*06* Digital output LB2*01* to LB2*17*, LB6*08*, LB6*10* to LB6*17* FB2*01* to FB2*17*, FB6*08*, FB6*10* to FB6*17* Relay output LB6001*, LB6006* FB6306*	Up to SIL 2
--	-------------

The *-marked letters of the type code are placeholders for versions of the device.

2.4 Standards and Directives for Functional Safety

Device-specific standards and directives

Functional safety	IEC/EN 61508, part 2, edition 2010: Functional safety of electrical/electronic/programmable electronic safety-related systems (manufacturer)
-------------------	---

System-specific standards and directives

Functional safety	IEC/EN 61511, part 1 – 3, edition 2003: Functional safety – Safety instrumented systems for the process industry sector (user)
-------------------	---

3 Planning

3.1 System Structure

3.1.1 Low Demand Mode of Operation

If there are two control loops, one for the standard operation and another one for the functional safety, then usually the demand rate for the safety loop is assumed to be less than once per year.

The relevant safety parameters to be verified are:

- the PFD_{avg} value (average **P**robability of dangerous **F**ailure on **D**emand) and the T₁ value (proof test interval that has a direct impact on the PFD_{avg} value)
- the SFF value (**S**afe **F**ailure **F**raction)
- the HFT architecture (**H**ardware **F**ault **T**olerance)

3.1.2 High Demand or Continuous Mode of Operation

If there is only one safety loop, which combines the standard operation and safety-related operation, then usually the demand rate for this safety loop is assumed to be higher than once per year.

The relevant safety parameters to be verified are:

- the PFH value (**P**robability of dangerous **F**ailure per **H**our)
- Fault reaction time of the safety system
- the SFF value (**S**afe **F**ailure **F**raction)
- the HFT architecture (**H**ardware **F**ault **T**olerance)

3.1.3 Safe Failure Fraction

The safe failure fraction describes the ratio of all safe failures and dangerous detected failures to the total failure rate.

$$\text{SFF} = (\lambda_s + \lambda_{dd}) / (\lambda_s + \lambda_{dd} + \lambda_{du})$$

A safe failure fraction as defined in IEC/EN 61508 is only relevant for elements or (sub)systems in a complete safety loop. The device under consideration is always part of a safety loop but is not regarded as a complete element or subsystem.

For calculating the SIL of a safety loop it is necessary to evaluate the safe failure fraction of elements, subsystems and the complete system, but not of a single device.

Nevertheless the SFF of the device is given in this document for reference.

3.2 Assumptions

The following assumptions have been made during the FMEDA:

- Failure rate based on the Siemens standard SN 29500.
- Failure rates are constant, wear is not considered.
- To build a SIL safety loop for the defined SIL, it is assumed as an example that this device uses 10 % of the available budget for PFD_{avg} /PFH.
- For a SIL 2 application operating in low demand mode the total PFD_{avg} value of the SIF (**S**afety **I**nstrumented **F**unction) should be smaller than 10^{-2} , hence the maximum allowable PFD_{avg} value would then be 10^{-3} .
- For a SIL 2 application operating in high demand mode the total PFH value of the SIF should be smaller than 10^{-6} per hour, hence the maximum allowable PFH value would then be 10^{-7} per hour.
- Since the safety loop has a hardware fault tolerance of **0** and it is a type **A** device, the SFF must be $> 60\%$ according to table 2 of IEC/EN 61508-2 for a SIL 2 (sub) system.
- The device will be used under average industrial ambient conditions comparable to the classification **stationary mounted** according to MIL-HDBK-217F.

Alternatively, operating stress conditions typical of an industrial field environment similar to IEC/EN 60654-1 Class C with an average temperature over a long period of time of $40\text{ }^{\circ}\text{C}$ may be assumed. For a higher average temperature of $60\text{ }^{\circ}\text{C}$, the failure rates must be multiplied by a factor of 2.5 based on experience. A similar factor must be used if frequent temperature fluctuations are expected.

- Multiple channels of one device can fail based on one common fault. Do not use multiple channels of one device in the same safety function.

3.3 Safety Function and Safe State

Safe State

The safe state is present when all outputs of the devices installed on the backplane are de-energized (0 V, 0 mA).

Safety Function

The outputs of the devices installed on the backplane are de-energized via the bus-independent control input on the backplane. The control input controls all devices with a shutdown input.

The following figure shows the implementation of the safety function via an output shutdown connected to the control input.

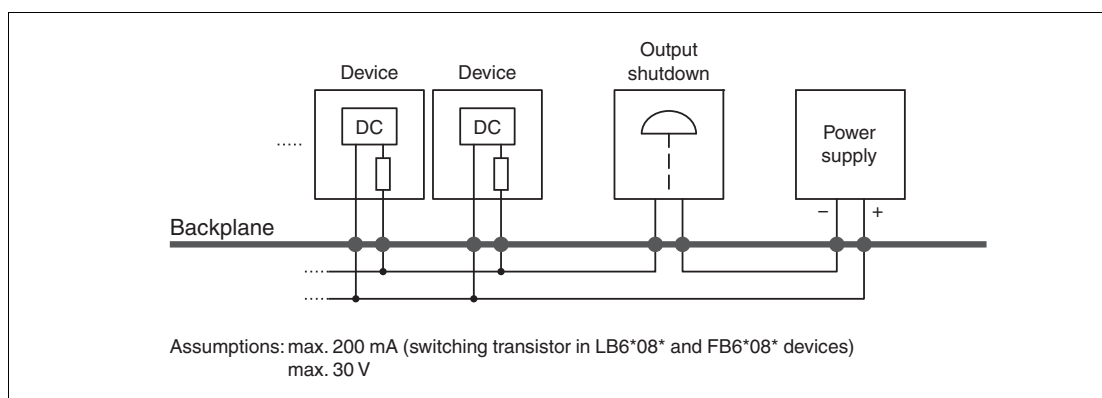

Figure 3.1 Basic structure of the safety function

Additional Safety Function for LB6*10* to LB6*15* and FB6*10* to FB6*15* Devices

The devices LB6*10* to LB6*15* and FB6*10* to FB6*15* are supplied via an additional external power supply (booster connection). This power supply interface can be used to deactivate the output safely as well by using an external safety device (i. e. safety relay to disconnect the power). The probability of a fault in the devices that activates the supply power to the outputs via the backplane supply is highly unlikely. Additional failure rates for the devices do not have to be taken into account for such an application.



Note

See corresponding datasheets for further information.

3.4 Characteristic Safety Values

Characteristic safety values for the following devices, used in a 1oo1 structure:

- LB2*01* to LB2*17*, LB6*16*, LB6*17*
- FB2*01* to FB2*17*, FB6*16*, FB6*17*

Parameters	Characteristic values	
Assessment type and documentation	FMEDA report	
Device type	A	
Operating mode	Low Demand Mode or High Demand Mode	
HFT	0	
SIL	2	
Safety function	De-energized to safe (DTS)	
Devices	LB2*01* to LB2*15* FB2*01* to FB2*15*	LB2*16*, LB2*17*, FB2*16*, FB2*17* LB6*16*, LB6*17*, FB6*16*, FB6*17*
λ_s	14.5 FIT	15.7 FIT
λ_{dd}	0 FIT	0 FIT
λ_{du}	5.4 FIT	9.4 FIT
λ_{total} (safety function)	19.9 FIT	25.1 FIT
SFF ¹	72 %	62 %
PTC	100 %	100 %
MTBF ²	4295 years	3437 years
PFH	5.41×10^{-9} 1/h	9.42×10^{-9} 1/h
PFD _{avg} for $T_1 = 1$ year	2.37×10^{-5} 1/h	4.13×10^{-5} 1/h
PFD _{avg} for $T_1 = 2$ years	4.74×10^{-5} 1/h	8.25×10^{-5} 1/h
PFD _{avg} for $T_1 = 5$ years	1.19×10^{-4} 1/h	2.06×10^{-4} 1/h
Reaction time ³	60 ms	60 ms

Table 3.1

¹ **No effect failures** are not influencing the safety function and are therefore not included in SFF.

² acc. to SN29500. This value includes failures which are not part of the safety function/MTTR = 8 h. The value is calculated for one safety function of the device.

³ Time between fault detection and fault reaction

Characteristic safety values for the following devices, used in a 1oo1 structure:

- LB4*02*2, LB4*05*2, LB4*06*, LB7*04*
- FB4*02*2, FB4*05*2, FB4*06*, FB7*04*

Parameters	Characteristic values
Assessment type and documentation	FMEDA report
Device type	A
Operating mode	Low Demand Mode or High Demand Mode
HFT	0
SIL	2
Safety function	De-energized to safe (DTS)
λ_s	15.7 FIT
λ_{dd}	0 FIT
λ_{du}	9.4 FIT
λ_{total} (safety function)	25.1 FIT
$\lambda_{no\ effect}$	8.1 FIT
$\lambda_{not\ part}$	0 FIT
SFF ¹	62 %
PTC	100 %
MTBF ²	3437 years
PFH	9.42×10^{-9} 1/h
PFD _{avg} for T ₁ = 1 year	4.13×10^{-5} 1/h
PFD _{avg} for T ₁ = 2 years	8.25×10^{-5} 1/h
PFD _{avg} for T ₁ = 5 years	2.06×10^{-4} 1/h
Reaction time ³	1 s

Table 3.2

- ¹ **No effect failures** are not influencing the safety function and are therefore not included in SFF.
- ² acc. to SN29500. This value includes failures which are not part of the safety function/MTTR = 8 h. The value is calculated for one safety function of the device.
- ³ Time between fault detection and fault reaction

Characteristic safety values for the following devices, used in a 1oo1 structure:

- LB6*08*, LB6*10* to LB6*15*
- FB6*08*, FB6*10* to FB6*15*

Parameters	Characteristic values	
Assessment type and documentation	FMEDA report	
Device type	A	
Operating mode	Low Demand Mode or High Demand Mode	
HFT	0	
SIL	2	
Safety function	De-energized to safe (DTS)	
Devices	LB6*08*, FB6*08*	LB6*10* to LB6*15* FB6*10* to FB6*15*
λ_s	13.1 FIT	18.0 FIT
λ_{dd}	0 FIT	0 FIT
λ_{du}	6.9 FIT	12.0 FIT
λ_{total} (safety function)	20.0 FIT	30.0 FIT
SFF ¹	65 %	60 %
PTC	100 %	100 %
MTBF ²	4295 years	1468 years
PFH	6.90×10^{-9} 1/h	1.20×10^{-8} 1/h
PFD _{avg} for T ₁ = 1 year	3.02×10^{-5} 1/h	5.26×10^{-5} 1/h
PFD _{avg} for T ₁ = 2 years	6.04×10^{-5} 1/h	1.05×10^{-4} 1/h
PFD _{avg} for T ₁ = 5 years	1.51×10^{-4} 1/h	2.62×10^{-4} 1/h
Reaction time ³	12 ms	30 ms

Table 3.3

- ¹ **No effect failures** are not influencing the safety function and are therefore not included in SFF.
- ² acc. to SN29500. This value includes failures which are not part of the safety function/MTTR = 8 h. The value is calculated for one safety function of the device.
- ³ Time between fault detection and fault reaction

Characteristic safety values for the following devices, used in a 1oo1 structure:

- LB6001*, LB6006*
- FB6306*

Parameters	Characteristic values
Assessment type and documentation	Full assessment
Device type	A
Mode of operation	Low demand mode oder high demand mode
HFT	0
SIL	2
Safety function	The output is switched to the safe (de-energized) state when the input from an attached switch is in open circuit.
λ_s	40 FIT
λ_{dd}	0 FIT
λ_{du}	25.6 FIT
$\lambda_{no\ effect}$	45.1 FIT
$\lambda_{total\ (safety\ function)}$	66 FIT
SFF ¹	61 %
PTC	100 %
MTBF ²	908 years
PFH	2.56×10^{-8} 1/h
PFD _{avg} for $T_1 = 1\ year$ ³	1.12×10^{-4}
PFD _{avg} for $T_1 = 2\ years$ ³	2.24×10^{-4}
PFD _{avg} for $T_1 = 5\ years$ ³	5.61×10^{-4}
Reaction time ⁴	$\leq 10\ ms$

Table 3.4

¹ **No effect failures** are not influencing the safety function and are therefore not included in SFF.

² acc. to SN29500. This value includes failures which are not part of the safety function/MTTR = 8 h. The value is calculated for one safety function of the device.

³ 8760 h/year

⁴ Time between fault detection and fault reaction

The characteristic safety values like PFD, PFH, SFF, HFT and T_1 are taken from the FMEDA report. Observe that PFD and T_1 are related to each other.

The function of the devices has to be checked within the proof test interval (T_1).

3.5 Useful Lifetime

Although a constant failure rate is assumed by the probabilistic estimation this only applies provided that the useful lifetime of components is not exceeded. Beyond this useful lifetime, the result of the probabilistic estimation is meaningless as the probability of failure significantly increases with time. This useful lifetime is highly dependent on the component itself and its operating conditions – temperature in particular. For example, electrolytic capacitors can be very sensitive to the operating temperature.

This assumption of a constant failure rate is based on the bathtub curve, which shows the typical behavior for electronic components.

Therefore it is obvious that failure calculation is only valid for components that have this constant domain and that the validity of the calculation is limited to the useful lifetime of each component.

It is assumed that early failures are detected to a huge percentage during the installation and therefore the assumption of a constant failure rate during the useful lifetime is valid.

The IEC/EN 61508-2 standard specifies a useful lifetime of 8 to 12 years for devices used within industrial environments. Observe that the useful lifetime can be reduced if the device is exposed to the following conditions:

- highly stressful environmental conditions such as constantly high temperatures
- temperature cycles with high temperature differences
- permanent repeated mechanical stress (vibration)

According to DIN EN 61508-2 standard note N3, appropriate measures taken by the manufacturer and plant operator can extend the useful lifetime.

Our experience has shown that the useful lifetime of a Pepperl+Fuchs product can be higher if the ambient conditions support a long useful lifetime, for example if the ambient temperature is significantly below the maximum ambient temperature.

Please note that the useful lifetime refers to the (constant) failure rate of the device. The effective lifetime can deviate from this.

The estimated useful lifetime is greater than the warranty period prescribed by law or the manufacturer's guarantee period. However, this does not result in an extension of the warranty or guarantee services. Failure to reach the estimated useful lifetime is not a material defect.

Derating

Observe the specified maximum switching cycles for devices that contain relays. For safety applications, reduce the number of switching cycles to up to 2/3 of the maximum value.

4 Mounting and Installation



Mounting and Installing the Device

1. Observe the safety instructions in the instruction manual.
2. Observe the information in the manual.
3. Observe the requirements for the safety loop.
4. Connect the device only to devices that are suitable for this safety application.
5. Check the safety function to ensure the expected output behavior.

4.1 Connection and Configuration of the Output Shutdown in the LB-System



Danger!

Danger to life from missing safety function

Many backplanes have DIP switches that can be used to bypass the output shutdown. If the shutdown is put out of service, the safety function is no longer guaranteed.

Prevent the access to the DIP switches and the manipulation of the output shutdown during operation. Use the Pepperl+Fuchs switch protection cover as described in the documentation.



Connecting and Configuring the Output Shutdown

1. Remove the switch protection cover.
2. Configure the output shutdown via DIP switches so that the safety function is active, see below
3. Connect the output shutdown, see below.
4. Mount the switch protection cover.

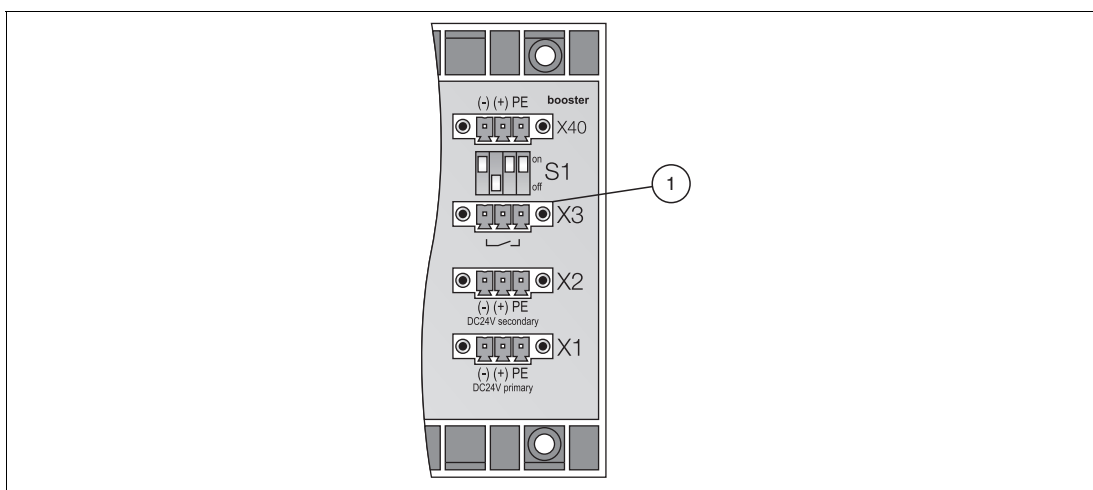

Figure 4.1 Position of the output shutdown on the backplane

- 1 **X3:** bus independent output shutdown of the I/O modules

Backplanes LB9022* to LB9029*
(Except LB9022S, LB9024S, LB9022BP22320.*, LB9024BP24300.*)

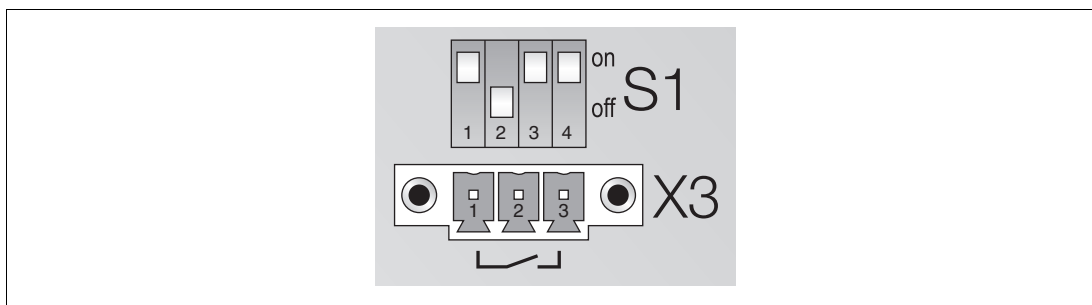

Figure 4.2 X3 terminals and S1 function switches



Danger!

Danger to life from missing safety function

If you set all DIP switches to **on**, the output shutdown is not active. The safety function is not guaranteed.

Set the DIP switches so that the output shutdown is controlled via the volt-free contact at the control input.

DIP switches S1.1 to S1.4				
S1.1	S1.2	S1.3	S1.4	
on	on	on	on	Output shutdown is not active, independent of control input X3.
on	off	on	on	Output shutdown is controlled via an external, volt-free contact at control input X3.

Table 4.1

Terminal assignment for control input X3:

- X3.1 = 0 V
Control terminal for all I/O modules with shutdown input.
- X3.1 to X3.3 for external volt-free contact (contact galvanically isolated from other contacts on other backplanes. See Figure 4.3, position (1)).

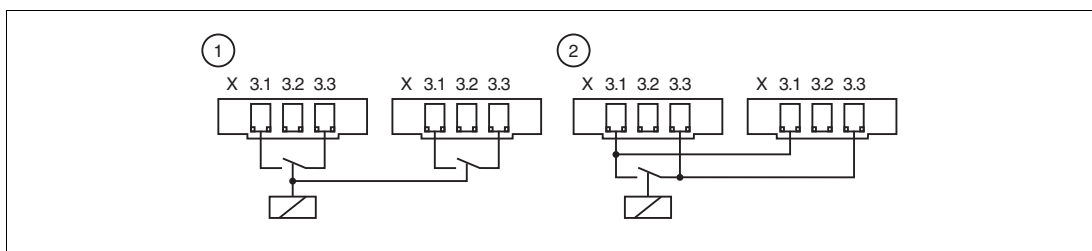

Figure 4.3 Control input X3

- 1 Control for 2 backplanes
- 2 Control for 2 backplanes with common contact
 - Base and expansion backplane can be controlled by either 1 or 2.
 - 2 backplanes with a larger distance can only be controlled by 1.

Backplanes LB9022S, LB9024S, LB9022BP22320.* , LB9024BP24300.*

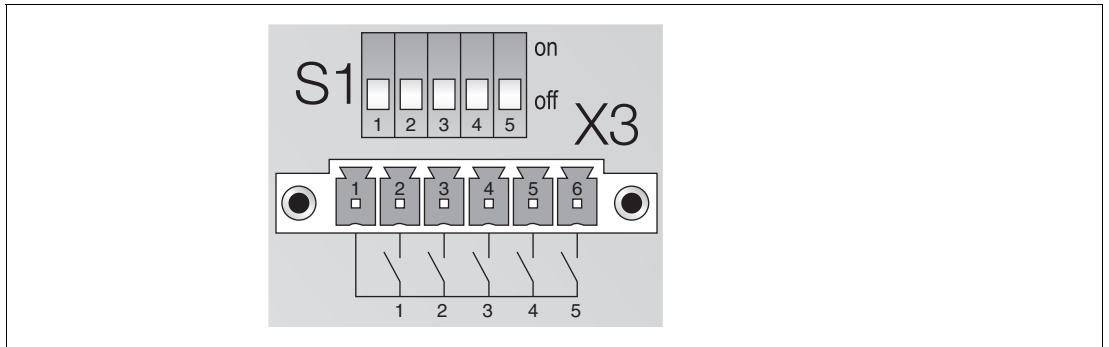

Figure 4.4 Steuereingang X3 und DIP-Schalter S1.1 ... S1.5

The output shutdown can be configured separately for 5 different segments (slot ranges) on the backplanes LB9022S, LB9024S, LB9022BP22320.* , and LB9024BP24300.* .

Segment	1	2	3	4	5
I/O module slots LB9022S, LB9022BP22320.*	3 to 5	6 to 10	11 to 15	16 to 20	21 to 24
I/O module slots LB9024S, LB9024BP24300.*	1 to 5	6 to 10	11 to 15	16 to 20	21 to 24
DIP switch S1	S1.1	S1.2	S1.3	S1.4	S1.5
Control input X3	X3.1	X3.2	X3.3	X3.4	X3.5

Table 4.2

The output shutdown for segment x is controlled with DIP switch S1.x and the volt-free contact at control input X3.x.



Danger!

Danger to life from missing safety function

If you set one of the DIP switches to **on**, the output shutdown of the corresponding devices is not active. The safety function is not guaranteed.

Set the DIP switches so that the output shutdowns are controlled via the volt-free contacts at the control input.

DIP switches S1	Control input X3	Effect
S1.x = on	X3.x = on/off	If the DIP switch S1.x is set to on , the output shutdown for segment x is not active, independent of control input X3.x.
S1.x = off	X3.x = on/off	If the DIP switch S1.x is set to off , the output shutdown of segment x is controlled via the volt-free contact at X3.x. All outputs of segment x are shut down if S1.x = off and X3.x = off .

Table 4.3

4.2 Connection of the Output Shutdown in the FB-System



Danger!

Explosion hazard from the use of non-approved devices

Devices which do not meet the requirements for use in explosion-hazardous areas can ignite an explosive mixture.

Only use volt-free contacts that are approved for operation in the respective environment. For installation in Zone 1, for example, use volt-free contacts designed in accordance with type of protection Ex e.



Connecting the Output Shutdown

1. To use the output shutdown of the I/O modules on slots 1 to 10, replace plug-in jumper 18/19 with an external, volt-free contact, see Figure 4.6.
2. To use the output shutdown of the I/O modules on slots 11 to 20 (not for FB9261BP10220.*), replace plug-in jumper 17/18 with an external, see Figure 4.6.

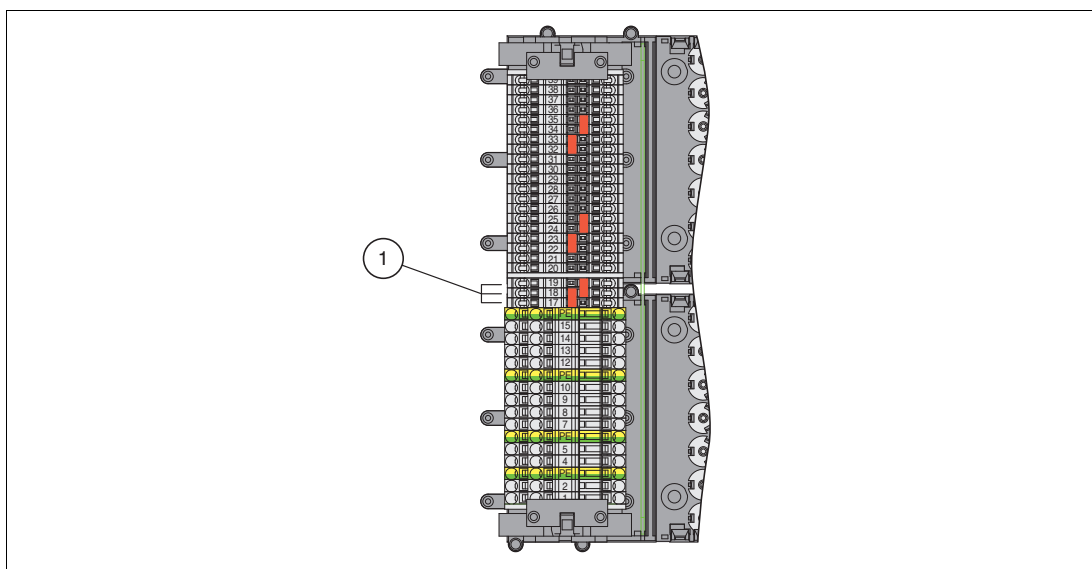

Figure 4.5 Position of the output shutdown on the backplane

Terminal	Plug-in jumper	Function
19	X	Terminals for bus independent output shutdown of the I/O modules
18	X	
17		<ul style="list-style-type: none"> • Plug-in jumpers inserted: output shutdown disabled • Plug-in jumpers not inserted: output shutdown enabled

Table 4.4

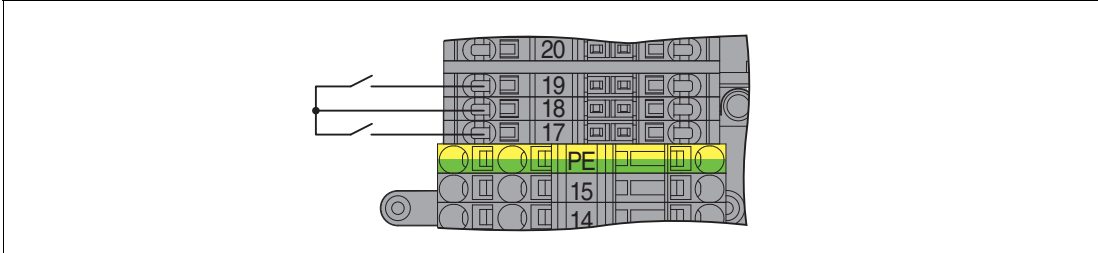

Figure 4.6 Output shutdown connection

5 Operation



Danger!

Danger to life from missing safety function

If the safety loop is put out of service, the safety function is no longer guaranteed.

- Do not deactivate the device.
- Do not bypass the safety function.
- Do not repair, modify, or manipulate the device.



Danger!

Danger to life from missing safety function

Many backplanes have DIP switches that can be used to bypass the output shutdown. If the output shutdown is put out of service, the safety function is no longer guaranteed.

Prevent the access to the DIP switches and the manipulation of the output shutdown during operation. Use the Pepperl+Fuchs switch protection cover as described in the documentation.



Operating the device

1. Observe the safety instructions in the instruction manual.
2. Observe the information in the manual.
3. Use the device only with devices that are suitable for this safety application.
4. Correct any occurring safe failures within 8 hours. Take measures to maintain the safety function while the device is being repaired.

5.1 Proof Test

The proof test must detect the dangerous undetected faults (λ_{du}), which have been noticed during the FMEDA.

Dangerous failures are limited to an incorrect or delayed reaction of the signal loop on activating the output shutdown. No dangerous failures occur if the signal loop reacts to the activation of the output shutdown within a defined time. To test this, the application running under maximum load must be shutdown. The previously defined time until the signal loop is de-energized must not be exceeded. By this, all dangerous undetected failures are revealed.

Assuming 10% of the failure budget of a safety loop to be available for the Remote I/O device results in a proof test interval of more than 100 years. It is possible that the device is used in other environments than specified within the assumptions for the FMEDA assessment so a different calculation is necessary. The calculations for the safety loop can also reveal that the device may claim a different amount of the PFD value (standard is 10%). Both effects have an influence on the proof test time.

It is under the responsibility of the plant operator to define the type of proof test and the interval time period.

6 Maintenance and Repair



Danger!

Danger to life from missing safety function

Changes to the device or a defect of the device can lead to device malfunction. The function of the device and the safety function is no longer guaranteed.

Do not repair, modify, or manipulate the device.



Maintaining, Repairing or Replacing the Device

In case of maintenance, repair or replacement of the device, proceed as follows:

1. Implement appropriate maintenance procedures for regular maintenance of the safety loop.
2. While the device is maintained, repaired or replaced, the safety function does not work. Take appropriate measures to protect personnel and equipment while the safety function is not available. Secure the application against accidental restart.
3. Do not repair a defective device. A defective device must only be repaired by the manufacturer.
4. If there is a defect, always replace the device with an original device.



Reporting Device Failure

If you use the device in a safety loop according to IEC/EN 61508, it is required to inform the device manufacturer about possible systematic failures.

Report all failures in the safety function that are due to functional limitations or a loss of device function – especially in the case of possible dangerous failures.

In these cases, contact your local sales partner or the Pepperl+Fuchs technical sales support (service line).

It is not necessary to report failures in the safety function that are due to external influences or damage.

7 List of Abbreviations

ESD	E mergency S hutdown
FIT	F ailure I n T ime in 10^{-9} 1/h
FMEDA	F ailure M ode, E ffects, and D iagnostics A nalysis
λ_s	Probability of safe failure
λ_{dd}	Probability of dangerous detected failure
λ_{du}	Probability of dangerous undetected failure
$\lambda_{\text{no effect}}$	Probability of failures of components in the safety loop that have no effect on the safety function.
$\lambda_{\text{not part}}$	Probability of failure of components that are not in the safety loop
$\lambda_{\text{total (safety function)}}$	Probability of failure of components that are in the safety loop
HFT	H ardware F ault T olerance
MTBF	M ean T ime B etween F ailures
MTTR	M ean T ime T o R estoration
PCS	P rocess C ontrol S ystem
PFD_{avg}	A verage P robability of dangerous F ailure on D emand
PFH	A verage frequency of dangerous failure per hour
PLC	P rogrammable L ogic C ontroller
PTC	P roof T est C overage
SC	S ystematic C apability
SFF	S afe F ailure F raction
SIF	S afety I nstrumented F unction
SIL	S afety I ntegrity L evel
SIS	S afety I nstrumented S ystem
T₁	P roof T est I nterval

Your automation, our passion.

Explosion Protection

- Intrinsic Safety Barriers
- Signal Conditioners
- FieldConnex® Fieldbus
- Remote I/O Systems
- Electrical Ex Equipment
- Purge and Pressurization
- Industrial HMI
- Mobile Computing and Communications
- HART Interface Solutions
- Surge Protection
- Wireless Solutions
- Level Measurement

Industrial Sensors

- Proximity Sensors
- Photoelectric Sensors
- Industrial Vision
- Ultrasonic Sensors
- Rotary Encoders
- Positioning Systems
- Inclination and Acceleration Sensors
- Fieldbus Modules
- AS-Interface
- Identification Systems
- Displays and Signal Processing
- Connectivity

Pepperl+Fuchs Quality

Download our latest policy here:

www.pepperl-fuchs.com/quality

