

Reliable Skid Control in Automotive Bodyshell Construction

R201 Retroreflective Sensors with
Polarization Filter Regulate Skid Speed

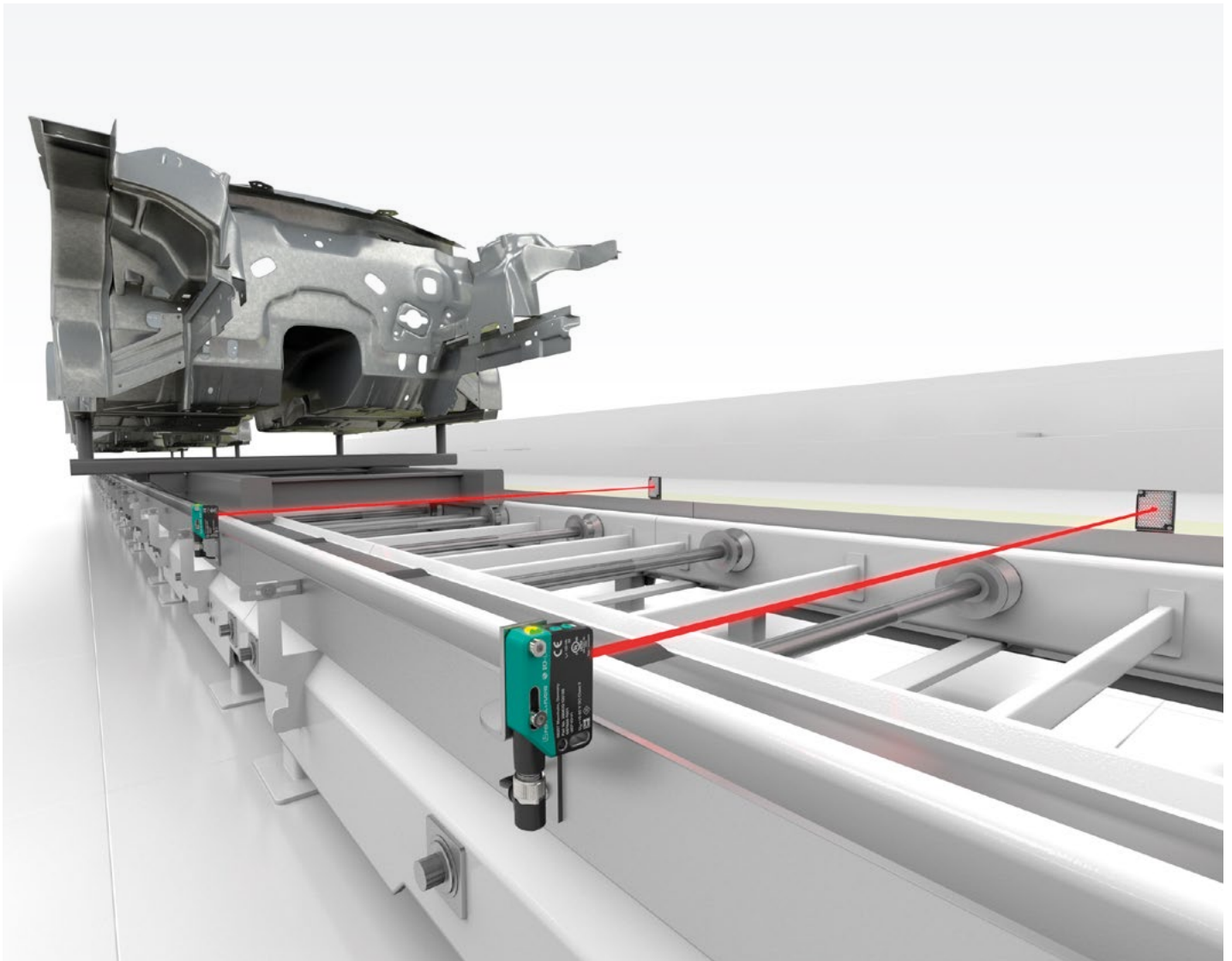

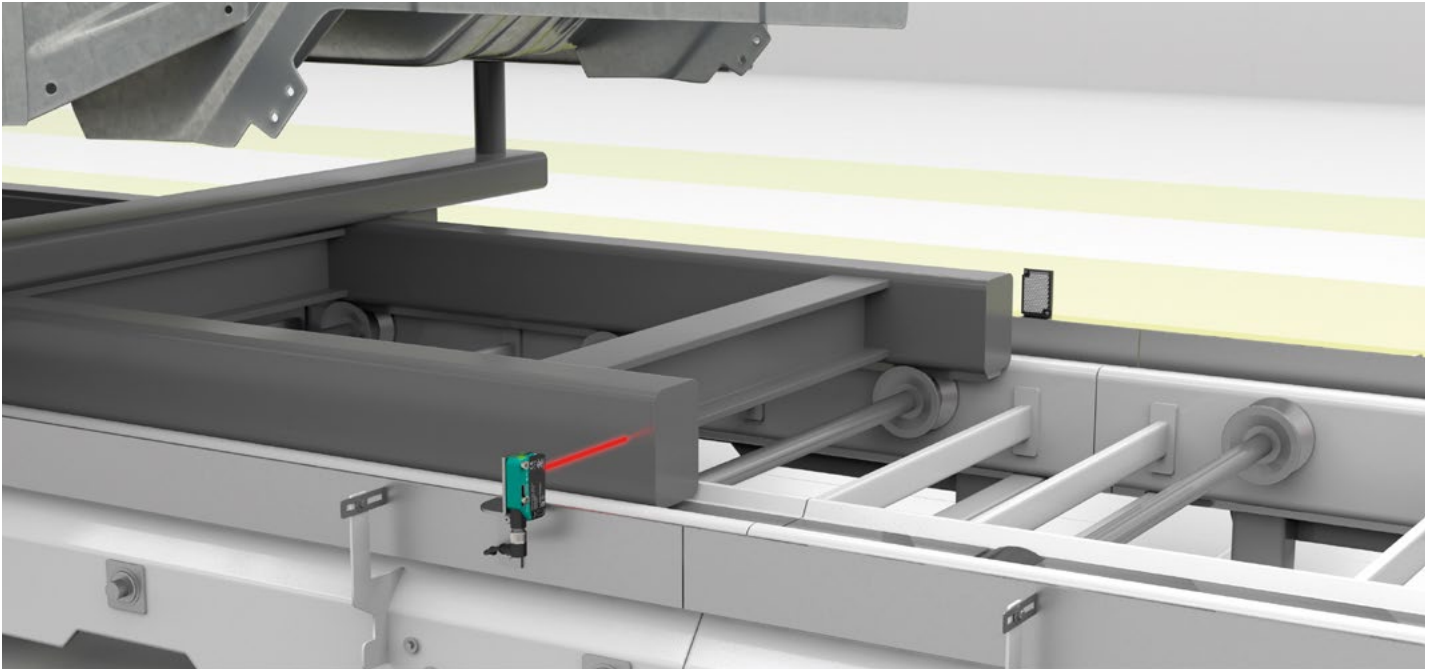

The Application

During the automotive manufacturing process, various components are added in stages to create the vehicle bodyshell. The components include sheet metal parts from the pressing plant; front, rear, and floor assemblies; and add-on parts such as doors and side walls. The components are moved along the production line on transport platforms—or skids—and delivered to the various production stations. At this point, robots weld, glue, or rivet the components together, or they grip and position them in preparation for assembly processes. During this process, there should only be one bodyshell at a time in each production station.

The Goal

If a production cell is already in use, the incoming skid must stop in front of the cell until entry is possible. The transport platform typically moves at speeds of around 60 m/min. In order to slow it down as gently as possible, the speed is gradually reduced before the platform comes to a complete stop. The photoelectric sensors that detect the skids must ensure complete reliability—even when the skids cause reflections and mirroring, and when there is extraneous light and other sources of interference from the plant environment.

The Solution

R201 series retroreflective sensors—which have a polarization filter that prevents disruptive light incidence from reaching the receiver element in the sensor—makes light work of this task. Reflective skid surfaces are reliably detected. When an incoming skid interrupts the light path between the first sensor and the reflector mounted on the opposite side, the transport speed is immediately reduced. By the time it reaches the second

R201 series retroreflective sensor, the transport platform has stopped. This reliable detection of skids enables efficient, interference-free control of the entire process.

The Benefits

R201 series retroreflective sensors with polarization filter can reliably detect even extremely glossy parts. Mirroring from the bodyshell and extraneous light from the environment do not inhibit reliable sensor performance. The R201 series for medium-sized applications is complemented by the impressive performance of the R200 series for larger operating ranges. All five series—the R201 and R200 alongside the smaller R100, R101, and R103 series for space-restricted applications—offer the same sensing modes, standard configurations, and one user interface for maximum flexibility.

At a Glance

- R201 retroreflective sensors with polarization filter: Maximum detection reliability in bright conditions and with mirroring and extraneous light
- Suitable for operating distances of up to 15 meters
- Standardized IO-Link connection via Smart Sensor Profile as the basis for Sensorik4.0®
- All photoelectric sensing modes in five standard housings for maximum flexibility and a variety of integration possibilities