

Functional Safety

**Inductive Varikont L2 Sensor
NS*-L2M-2E2-*-S2D2**

Manual

SIL

IEC 61508/61511



CE SIL 2 PL d

With regard to the supply of products, the current issue of the following document is applicable:
The General Terms of Delivery for Products and Services of the Electrical Industry, published by the Central Association of the Electrical Industry (Zentralverband Elektrotechnik und Elektroindustrie (ZVEI) e.V.) in its most recent version as well as the supplementary clause: "Expanded reservation of proprietorship"

Worldwide

Pepperl+Fuchs Group

Lilienthalstr. 200

68307 Mannheim

Germany

Phone: +49 621 776 - 0

E-mail: info@de.pepperl-fuchs.com

North American Headquarters

Pepperl+Fuchs Inc.

1600 Enterprise Parkway

Twinsburg, Ohio 44087

USA

Phone: +1 330 425-3555

E-mail: sales@us.pepperl-fuchs.com

Asia Headquarters

Pepperl+Fuchs Pte. Ltd.

P+F Building

18 Ayer Rajah Crescent

Singapore 139942

Phone: +65 6779-9091

E-mail: sales@sg.pepperl-fuchs.com

<https://www.pepperl-fuchs.com>

1	Introduction	5
1.1	Content of this Document	5
1.2	Safety Information	6
1.3	Symbols Used	7
2	Product Description	8
2.1	Function	8
2.2	Interfaces	8
2.3	Marking	8
2.4	Standards and Directives for Functional Safe	9
3	Planning	10
3.1	Assumptions	10
3.2	Safety Function and Safe State	11
3.3	Characteristic Safety Values	13
3.4	Useful Lifetime	14
4	Mounting and Installation	15
4.1	Mounting	15
4.2	Connection	19
4.3	Configuration	20
5	Operation	21
5.1	Functional Test	21
5.2	Proof Test	22
5.3	Indication of the Operating States	22
6	Maintenance and Repair	23
7	List of Abbreviations	24

1 Introduction

1.1 Content of this Document

This document contains information for usage of the device in functional safety-related applications. You need this information to use your product throughout the applicable stages of the product life cycle. These can include the following:

- Product identification
- Delivery, transport, and storage
- Mounting and installation
- Commissioning and operation
- Maintenance and repair
- Troubleshooting
- Dismounting
- Disposal

**Note**

This document does not substitute the instruction manual.

**Note**

For full information on the product, refer to the instruction manual and further documentation on the Internet at www.pepperl-fuchs.com.

**Note**

For specific device information such as the year of construction, scan the QR code on the device. As an alternative, enter the serial number in the serial number search at www.pepperl-fuchs.com.

The documentation consists of the following parts:

- Present document
- Instruction manual
- Datasheet

Additionally, the following parts may belong to the documentation, if applicable:

- EU-type examination certificate
- EU declaration of conformity
- Attestation of conformity
- Certificates
- Control drawings
- FMEDA report
- Assessment report
- Additional documents

For more information about Pepperl+Fuchs products with functional safety, see www.pepperl-fuchs.com/sil.

1.2 Safety Information

Target Group, Personnel

Responsibility for planning, assembly, commissioning, operation, maintenance, and dismantling lies with the plant operator.

Only appropriately trained and qualified personnel may carry out mounting, installation, commissioning, operation, maintenance, and dismantling of the product. The personnel must have read and understood the instruction manual and the further documentation.

Intended Use

The device is only approved for appropriate and intended use. Ignoring these instructions will void any warranty and absolve the manufacturer from any liability.

The device is developed, manufactured and tested according to the relevant safety standards.

Use the device only

- for the application described
- with specified environmental conditions
- with devices that are suitable for this safety application

Improper Use

Protection of the personnel and the plant is not ensured if the device is not used according to its intended use.

1.3 Symbols Used

This document contains symbols for the identification of warning messages and of informative messages.

Warning Messages

You will find warning messages, whenever dangers may arise from your actions. It is mandatory that you observe these warning messages for your personal safety and in order to avoid property damage.

Depending on the risk level, the warning messages are displayed in descending order as follows:



Danger!

This symbol indicates an imminent danger.

Non-observance will result in personal injury or death.



Warning!

This symbol indicates a possible fault or danger.

Non-observance may cause personal injury or serious property damage.



Caution!

This symbol indicates a possible fault.

Non-observance could interrupt the device and any connected systems and plants, or result in their complete failure.

Informative Symbols



Note

This symbol brings important information to your attention.



Action

This symbol indicates a paragraph with instructions. You are prompted to perform an action or a sequence of actions.

2 Product Description

2.1 Function

The device is an inductive sensor (proximity sensor). If an electrical conductive object, also known as a measuring plate, is inside the sensing range of the sensor coil, the magnetic field of the coil is influenced and an electrical switching signal is generated. The device can be operated in 3-wire or 4-wire circuits.

The device has 2 OSSD outputs with normally open function. The outputs switch to the off state according to their defined behavior under fault conditions (PDDb). If there is no object inside the sensing range, the outputs are high-impedance (off state). These outputs are compatible with the digital input types 1, 2 or 3 according to IEC/EN 61131-2.

The device transmits the digital signal to a safety PLC.

Display Elements

The device has 2 status indications. The following states are displayed:

- The yellow status indication lights up when the outputs are low-impedance (on state).
- The red status indication lights up when a fault occurs.

Note

See corresponding datasheets for further information.

2.2 Interfaces

The device has the following interfaces:

- Safety-related interface: digital outputs OSSD1 and OSSD2
- Non-safety-related interface: none

Note

For corresponding connections see datasheet.

2.3 Marking

Pepperl+Fuchs Group Lilienthalstraße 200, 68307 Mannheim, Germany	
Internet: www.pepperl-fuchs.com	
Inductive sensors, Varikont design	Up to SIL 3 and category 4, PL e

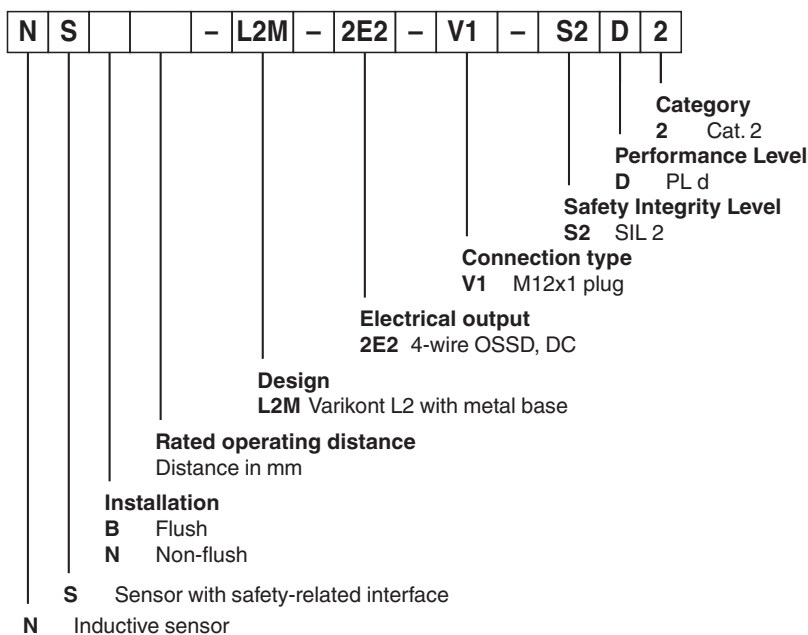

2.4 Standards and Directives for Functional Safe

Device specific standards and directives

Functional safety	IEC/EN 61508, part 1 – 7, edition 2010: Functional safety of electrical/electronic/programmable electronic safety-related systems (manufacturer)
Machinery Directive 2006/42/EC	<ul style="list-style-type: none"> EN ISO 13849-1:2023: Safety of machinery – Safety-related parts of control systems part 1: General principles for design IEC/EN 62061:2021: Safety of machinery – Functional safety of safety-related electrical, electronic and programmable electronic control systems EN 60947-5-3:2013: Low-voltage switchgear and controlgear, control circuit devices and switching elements - requirements for proximity devices with defined behavior under fault conditions (PDDb)

3 Planning

3.1 Assumptions

The following assumptions have been made during the FMEDA:

- Failure rate based on the Siemens standard SN 29500.
- Failure rates are constant, wear is not considered.
- External power supply failure rates are not included.
- The safety-related device is considered to be of type **A** device with a hardware fault tolerance of **0**.
- The device will be used under average industrial ambient conditions comparable to the classification **stationary mounted** according to MIL-HDBK-217F.

Alternatively, operating stress conditions typical of an industrial field environment similar to IEC/EN 60654-1 Class C with an average temperature over a long period of time of 40 °C may be assumed. For a higher average temperature of 60 °C, the failure rates must be multiplied by a factor of 2.5 based on experience. A similar factor must be used if frequent temperature fluctuations are expected.

- If both outputs of one device are used in redundancy in a safety loop, the output reaction must be compared using the discrepancy time, see chapter 3.3.

Applications according to IEC/EN 61508

- The device claims less than 35 % of the total failure budget for a SIL 2 safety loop.
- For a SIL 2 application operating in low demand mode the total PFD_{avg} value of the SIF (**S**afety **I**nstrumented **F**unction) should be smaller than 1×10^{-2} , hence the maximum allowable PFD_{avg} value would then be 3.5×10^{-3} .
- For a SIL 2 application operating in high demand mode the total PFH value of the SIF should be smaller than 1×10^{-6} per hour, hence the maximum allowable PFH value would then be 3.5×10^{-7} per hour.
- Since the safety loop has a hardware fault tolerance of **0** and it is a type **A** device, the SFF must be > 60 % according to table 2 of IEC/EN 61508-2 for a SIL 2 (sub) system.

Applications according to IEC/EN 62061 and EN ISO 13849-1

- The device was qualified for use in safety functions acc. to IEC/EN 62061 and EN ISO 13849-1. The device fulfills the requirements for a SIL_{CL} of SIL 2 according to IEC/EN 62061 and PL d acc. to EN ISO 13849-1. If 2 devices are used in redundancy in a safety loop, the device may be used in applications up to SIL 3, category 3/4, PL e.
- For a category 2 PL d application, the diagnostic coverage DC must at least be low (> 60 %). For a category 3/4, PL e application, the diagnostic coverage DC must at least be medium (> 90 %).

3.2 Safety Function and Safe State

Safe State

The safe state of the device is the high impedance state (off state).

Safety functions where the safe state is the low impedance state (on state) were not evaluated.

A dangerous failure is present if the device does not signal the safe state.

Safety Function

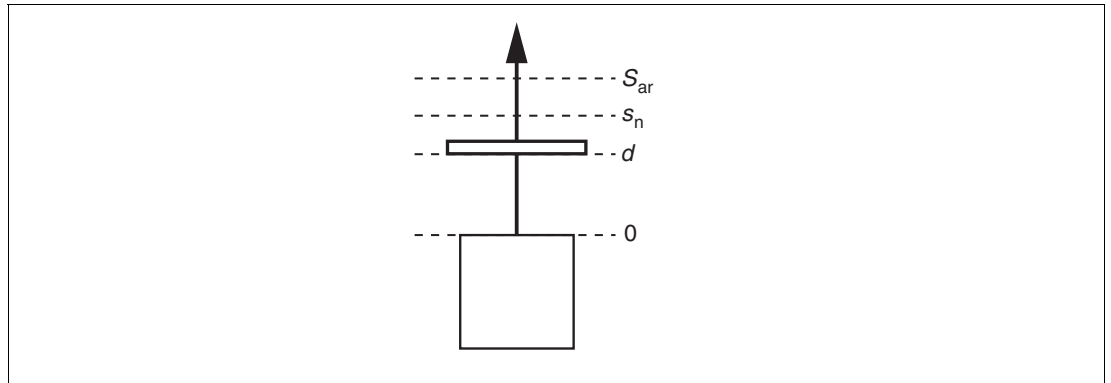

Figure 3.1 Distance values for the design of the safety function (abstract figure)

- d** Current distance of the measuring plate
- s_n** Rated operating distance
- s_{ar}** Assured release distance of a PDDB

The sensor signals the safe state when the reference object is outside of the assured release distance s_{ar} ($d > s_{ar}$).

These distances are valid when using the following reference objects:

Design	NSB15	NSN20
Mounting conditions	flush	non-flush
Dimensions of the reference object (a x b x c)	45 mm x 45 mm x 1 mm	60 mm x 60 mm x 1 mm
Material of the reference object	FE360 - ST37K	
s_n	15 mm	20 mm
s_{ar}	22.5 mm	30 mm
Safety reaction time	≤ 80 ms	≤ 80 ms

Table 3.1

Reaction Times

The safety reaction time is the maximum time required from the removal of the reference object to the reaction of the outputs in normal operation without faults.

The combined fault detection and fault reaction time is the time in which the sensor outputs react to an occurred fault. This time depends on the application, see chapter 3.3.

The discrepancy time is the time in which the device's OSSD1 and OSSD2 outputs can indicate different switching states during a switching operation. The discrepancy time is 1 ms. If both outputs of one device are used in redundancy in a safety loop, the output reaction must be compared, see chapter 3.3. Only compare the output reaction after the discrepancy time has ended, as the outputs may show different reactions during the switching operation.

Cross Fault

A cross fault is a short circuit between the outputs or between an output and the supply. Depending on the cross fault, the fault is detected and indicated immediately or during the next switching operation.

The fault causes at least one output to switch continuously to the safe state (off state). The safe state ends when the fault condition is over and the power supply is switched off and on again.

Conditions for correct cross fault detection:

max. capacitive load of 20 nF, max. lead resistance of 10 Ω .

3.3 Characteristic Safety Values

Parameter	Characteristic values		
Assessment type and documentation	Full assessment		
Device type	A		
Mode of operation	Low Demand Mode, High Demand Mode or Continuous Mode		
HFT	0	1	0
Safety function	Safety loop via the OSSD1 and OSSD2 outputs of one sensor (1oo2)	Safety loop via the OSSD1 outputs of 2 sensors (1oo2)	Safety loop via the OSSD1 output of one sensor (1oo1)
SIL	2	3	2
SIL _{CL}	2	3	2
SC	3	3	3
Category	2	3/4 ¹	–
PL	d	e	–
Interval of the function test ²	maximum 1 year	–	–
λ_s^3	36.8 FIT	74 FIT	36.8 FIT
λ_{dd}	25.7 FIT	79 FIT	21.3 FIT
λ_{du}	14.9 FIT	1.93 FIT	19.3 FIT
SFF ³	80 %	98.7 %	75 %
DC	63 % (low)	97.6 % (medium)	52 %
MTBF ⁴	557 years	278 years	557 years
MTTF _D	7600 years	59000 years	5900 years
PFH	1.49×10^{-8} 1/h	1.93×10^{-9} 1/h	1.93×10^{-8} 1/h
PFD _{avg} for T ₁ = 1 year	6.51×10^{-5}	8.44×10^{-6}	8.44×10^{-5}
PFD _{avg} for T ₁ = 2 years	1.30×10^{-4}	1.69×10^{-5}	1.69×10^{-4}
PFD _{avg} for T ₁ = 5 years	3.25×10^{-4}	4.22×10^{-5}	4.22×10^{-4}
Fault reaction time ⁵	< 200 ms	< 5 ms	< 5 ms
Useful lifetime T _M	maximum 20 years		

Table 3.2

¹ Make sure that both sensors switch when required. Depending on the design of the following circuit, the safety circuit can reach category 3 or 4. The safety PLC must be able to evaluate that the switching signals are synchronous.

² See chapter 5.1.

³ "No effect failures" are not influencing the safety function and are therefore not included in SFF and in the failure rates of the safety function.

⁴ acc. to SN29500. This value includes failures which are not part of the safety function/MTTR = 24 h. The value is calculated for one safety function of the device.

⁵ Time between fault occurrence and fault reaction, including cross fault detection

The characteristic safety values like PFD, PFH, SFF, HFT and T₁ are taken from the FMEDA report. Observe that PFD and T₁ are related to each other.

The function of the devices has to be checked within the proof test interval (T₁).

3.4 Useful Lifetime

Although a constant failure rate is assumed by the probabilistic estimation this only applies provided that the useful lifetime of components is not exceeded. Beyond this useful lifetime, the result of the probabilistic estimation is meaningless as the probability of failure significantly increases with time. This useful lifetime is highly dependent on the component itself and its operating conditions – temperature in particular. For example, electrolytic capacitors can be very sensitive to the operating temperature.

This assumption of a constant failure rate is based on the bathtub curve, which shows the typical behavior for electronic components.

Therefore it is obvious that failure calculation is only valid for components that have this constant domain and that the validity of the calculation is limited to the useful lifetime of each component.

It is assumed that early failures are detected to a huge percentage during the installation and therefore the assumption of a constant failure rate during the useful lifetime is valid.

The EN ISO 13849-1 standard defines a useful lifetime T_M for devices used within industrial environments. For the useful lifetime of the device described here refer to chapter 3.3. Observe that the useful lifetime can be reduced if the device is exposed to the following conditions:

- highly stressful environmental conditions such as constantly high temperatures
- temperature cycles with high temperature differences
- permanent repeated mechanical stress (vibration)

According to DIN EN 61508-2 standard note N3, appropriate measures taken by the manufacturer and plant operator can extend the useful lifetime.

Our experience has shown that the useful lifetime of a Pepperl+Fuchs product can be higher if the ambient conditions support a long useful lifetime, for example if the ambient temperature is significantly below the maximum ambient temperature.

Please note that the useful lifetime refers to the (constant) failure rate of the device. The effective lifetime can deviate from this.

The estimated useful lifetime is greater than the warranty period prescribed by law or the manufacturer's guarantee period. However, this does not result in an extension of the warranty or guarantee services. Failure to reach the estimated useful lifetime is not a material defect.

4 Mounting and Installation



Mounting and Installing the Device

1. Observe the safety instructions in the instruction manual.
2. Observe the information in the manual.
3. Observe the requirements for the safety loop.
4. Connect the device only to devices that are suitable for this safety application.
5. Check the safety function to ensure the expected output behavior.

4.1 Mounting

This sensor has no dead band in which the function is unsafe. Failures are indicated via the outputs and via the 2 status indications.



Danger!

Danger to life from loss of safety function

If an electrically conductive material is unintentionally placed near the active area, the safety function is no longer guaranteed.

- Take appropriate measures to prevent electrical conductive material, with the exception of the designated measuring plate, is placed near the active area.
 - Mount the device according to the application.
 - Setup the device according to the application. Keep the required operating distances.
 - Check the assured distances.
-



Mounting the Sensor

1. Mount the sensor. Observe the mounting conditions, see chapter 4.1.1 and figure below.
2. To align the active surface of the sensor (1), loosen the screws (2).
3. Align the active surface of the sensor (1) according to your application, see chapter 4.1.1.
4. Tighten the screws (2) with the recommended tightening torque.
5. Mount the sensor (1) on a suitable mounting surface (4).
6. Tighten the screws (3) with the recommended tightening torque.

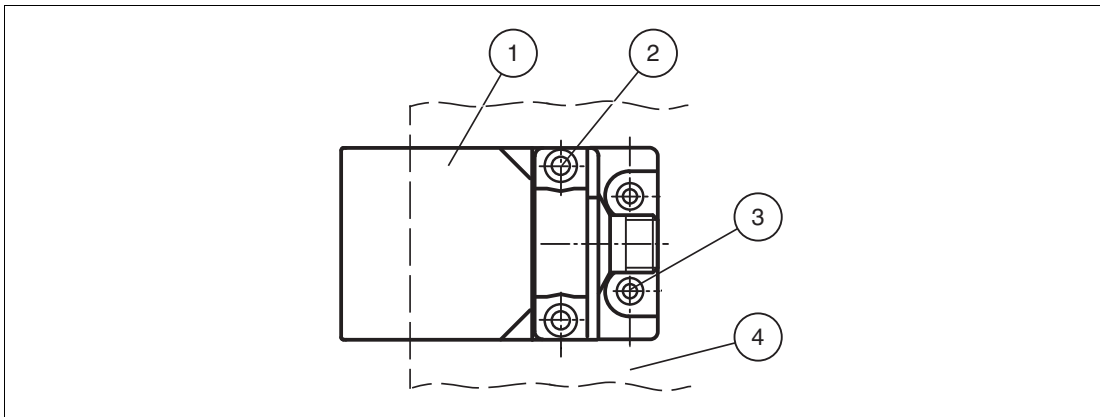

Figure 4.1

- | | |
|---|--|
| 1 | Sensor |
| 2 | M6 screw, recommended tightening torque 4 Nm |
| 3 | M5 screw, recommended tightening torque 2.7 Nm |
| 4 | Mounting surface |



Mounting the Measuring Plate

In a real application, a customer-specific measuring plate, not the reference object according to IEC/EN 60947-5-2, will probably be used. If a customer-specific measuring plate is used, observe the following notes:

- To achieve the safe state, move the measuring plate more than $3 \times s_n$ away from the active area of the sensor.
- If the distance $3 \times s_n$ is too large for your application, determine the real switching distance of the measuring plate.
If the real switching distance is $\leq s_n$, you may use the distance S_{ar} . See datasheet.
If the real switching distance is $> s_n$, the distance S_{ar} is 1.5 times the real switching distance.
- Even if the measuring plate approaches from the side, make sure that it leaves the measuring range far enough to reach the safe state.

4.1.1 Installation Conditions for Inductive Varikont L Safety Sensors Varikont L with Active Surface in Front

Sensors for Flush Mounting

Type	Installation situation								
Dimension in mm	X	X	Y		Y		B	Y	X
NSB15-L2M	≥ 0	≥ 0	≥ 0		≥ 0		≥ 45	≥ 40	≥ 60

Table 4.1

Sensors for Non-flush Mounting

Type	Installation situation									
Dimension in mm	X	X	X	Y	X	Y	B	X	Y	X
NSN20-L2M	≥ 30	≥ 0	≥ 0	≥ 10	≥ 0	≥ 20	≥ 60	≥ 0	≥ 80	≥ 80

Table 4.2

Varikont L with Active Top Surface

Sensors for Flush Mounting

Type	Installation situation				
		$A \leq 40$	$A \leq 40$	$A = \text{any}$	$A = \text{any}$
Dimension in mm	X	Y	Y	Y	Y
NSB15-L2M	≥ 0	≥ 0	≥ 0	≥ 5	≥ 10

Table 4.3

Sensors for Non-flush Mounting

Type	Installation situation								
		$A \leq 40$	$A \leq 40$	$A = \text{any}$	$A = \text{any}$				
Dimension in mm	X	X	Y	X	Y	X	Y	X	Y
NSN20-L2M	≥ 0	≥ 0	≥ 10	≥ 0	≥ 20	≥ 0	≥ 10	≥ 0	≥ 20

Table 4.4

4.2 Connection



Caution!

Danger to life from loss of safety function

If the supply voltage exceeds 40 V DC in a fault condition, the safety function is no longer guaranteed.

Take appropriate measures to prevent that the supply voltage exceeds 40 V DC. Use a suitable power supply.



Connecting the Sensor

Only connect the device to suitable digital inputs. The device is compatible with digital inputs of type 1, 2 or 3 according to IEC/EN 61131-2.

Connect the device according to the required safety circuits. The supply voltage can be found in the datasheet.

- If you are using the sensor in a safety loop for category 2, PL d, SIL 2, connect the sensor via the OSSD1 and OSSD2 outputs, see Figure 4.2. Observe that the OSSD1 and OSSD2 outputs can have different switching states during the discrepancy time, see chapter 3.2. If the difference between the switching states of the outputs occurs longer the discrepancy time, this is to be evaluated as an fault. Take appropriate measures.
- If you are using the sensor in a safety loop for category 3/4, PL e, SIL 3, connect 2 sensors via their OSSD1 outputs, see Figure 4.3. The OSSD2 output is not connected in this application.
- If you are using the sensor in a safety loop for SIL 2, connect the sensor via the OSSD1 output, see Figure 4.4. The OSSD2 output is not used for the safety function. Protect possibly not connected output lines against short circuit.

Safety Loop via the OSSD1 and OSSD2 Outputs (1oo2)

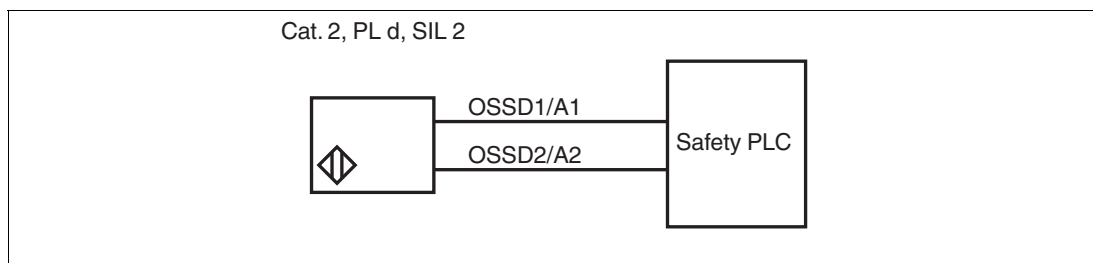

Figure 4.2 Example of a safety loop via the OSSD1 and OSSD2 outputs

Safety Loop via the OSSD1 Outputs of 2 Sensors (1oo2)

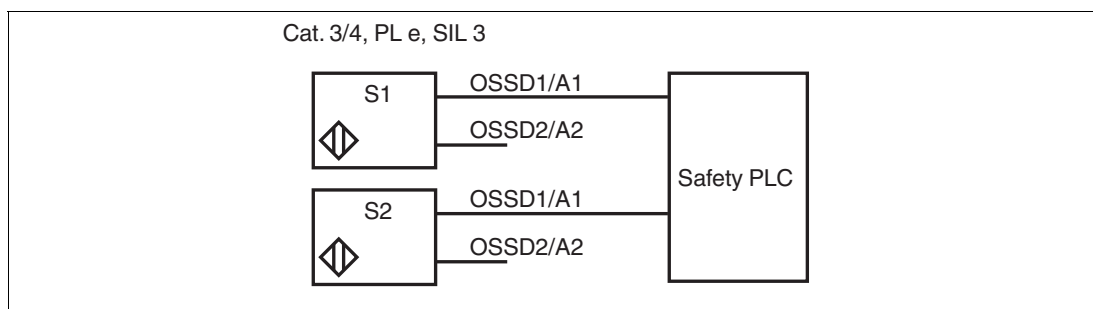

Figure 4.3 Example of a safety loop via the OSSD1 outputs of 2 sensors

Safety Loop via the OSSD1 Output (1oo1)

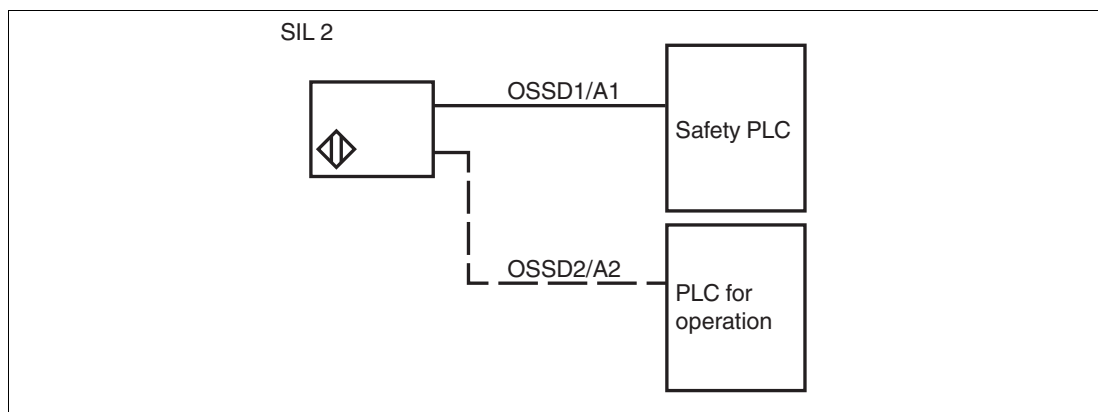

Figure 4.4 Example of a safety loop via the OSSD1 output



Note

See corresponding datasheets for further information.

4.3

Configuration

A configuration of the device is not necessary and not possible.

5 Operation



Danger!

Danger to life from missing safety function

If the safety loop is put out of service, the safety function is no longer guaranteed.

- Do not deactivate the device.
- Do not bypass the safety function.
- Do not repair, modify, or manipulate the device.



Operating the device

1. Observe the safety instruction in the instruction manual.
2. Observe the information in the manual.
3. Use the device only with devices that are suitable for this safety application.
4. Correct any occurring safe failures within 24 hours. Take measures to maintain the safety function while the device is being replaced.

5.1 Functional Test

This functional test is only required for EN ISO 13849-1, category 2 applications.



Functional Test Procedure

A one-time check of the correct function within the application is sufficient.

In category 2 safety loops, it is typical to check safety function once a day or when switching on the device.

Since this device has low failure rates and the internal structure of the device is similar to the structure of category 3 safety loops, you can extend the functional test interval to up to 1 year.

Choose the functional test interval depending on the stress of the device in the application, e. g., after stressful environmental conditions or mechanical stress.

Choose the functional test interval taking into account the operating procedures, e. g., always on Mondays, on the first of a month, etc.

5.2 Proof Test

This proof test is only required for low demand applications.



Proof Test Procedure

For this proof test, no proof test coverage (PTC) can be specified because only a complete test over the temperature range can reveal an unacceptable shift of the switch point.

The safety characteristic values are, however, considered low enough to continually manage without proof test.

1. Check the device for housing damages. If moisture penetrates into the device or internal components of the device are damaged, this can lead to unpredictable effects.
2. Check that the device is working correctly. If the device is not working correctly or not working, replace the device.
3. If both outputs are used in redundancy in a safety loop, check whether both outputs switch to the same state within the specified time between signal and diagnosis (discrepancy time), see chapter 3.2.
4. Faults are indicated via the 2 status indications. Check the correct function of the status indications during regular inspection. The meaning of the status indications is shown in the table.
5. Compare the signal behavior of the outputs by a safety PLC.
↳ The signal behavior has to be synchronous.
6. Check the correct behavior of the safety loop. Is the configuration correct?

5.3 Indication of the Operating States

The operating states are indicated via the 2 status indications. The indications has the following states:

- On = on state = low-impedance
- Off = off state = high-impedance

Operating state	OSSD1	OSSD2	LED
Measuring plate in the assured operating distance	On	On	Yellow
Measuring plate in the assured release distance	Off	Off	Off
No power supply	Off	Off	Off
Low voltage/overvoltage	Off	Off	Red
Cross fault ¹	At least one output is switched off ² .		Red
Detected internal fault	At least one output is switched off.		Red

Table 5.1

¹ See chapter 3.2.

² The fault causes at least one output to switch constantly to the safe state (off state). The safe state is indicated via status indication. The safe state ends when the fault condition is over and the power supply is switched off and on again.

6 Maintenance and Repair



Danger!

Danger to life from missing safety function

Changes to the device or a defect of the device can lead to device malfunction. The function of the device and the safety function is no longer guaranteed.

Do not repair, modify, or manipulate the device.



Maintaining or Replacing the Device

In case of maintenance or replacement of the device, proceed as follows:

1. Implement appropriate maintenance procedures for regular maintenance of the safety loop.
2. While the device is maintained or replaced, the safety function does not work.
Exception: The safety function is still guaranteed if the device is operated in redundancy. Take appropriate measures to protect personnel and equipment while the safety function is not available.
Secure the application against accidental restart.
3. Do not repair a defective device.
4. If there is a defect, always replace the device with an original device.



Reporting Device Failure

If you use the device in a safety loop according to IEC/EN 61508, it is required to inform the device manufacturer about possible systematic failures.

Report all failures in the safety function that are due to functional limitations or a loss of device function – especially in the case of possible dangerous failures.

In these cases, contact your local sales partner or the Pepperl+Fuchs technical sales support (service line).

It is not necessary to report failures in the safety function that are due to external influences or damage.

7 List of Abbreviations

DC	D agnostic C overage of dangerous faults
FIT	F ailure I n T ime in 10^{-9} 1/h
FMEDA	F ailure M ode, E ffects, and D iagnostics A nalysis
λ_s	Probability of safe failure
λ_{dd}	Probability of dangerous detected failure
λ_{du}	Probability of dangerous undetected failure
$\lambda_{\text{no effect}}$	Probability of failures of components in the safety loop that have no effect on the safety function.
$\lambda_{\text{not part}}$	Probability of failure of components that are not in the safety loop
$\lambda_{\text{total (safety function)}}$	Probability of failure of components that are in the safety loop
HFT	H ardware F ault T olerance
MTBF	M ean T ime B etween F ailures
MTTF_D	M ean T ime T o dangerous F ailure
MTTR	M ean T ime T o R estoration
OSSD	O utput S ignal S witching D evice
PDDB	P roximity D evice with D efined B ehaviour under fault conditions
PF_D_{avg}	A verage P robability of dangerous F ailure on D emand
PFH	A verage frequency of dangerous failure per hour
PL	P erformance L evel
PLC	P rogrammable L ogic C ontroller
PTC	P roof T est C overage
S_{ao}	A ssured operating distance of a PDDB
s_n	R ated operating distance
SC	S ystematic C apability
SFF	S afe F ailure F raction
SIL	S afety I ntegrity L evel
T₁	P roof T est I nterval
T_M	U seful lifetime according to EN ISO 13849-1 (mission time)

Your automation, our passion.

Explosion Protection

- Intrinsic Safety Barriers
- Signal Conditioners
- FieldConnex® Fieldbus
- Remote I/O Systems
- Electrical Ex Equipment
- Purge and Pressurization
- Industrial HMI
- Mobile Computing and Communications
- HART Interface Solutions
- Surge Protection
- Wireless Solutions
- Level Measurement

Industrial Sensors

- Proximity Sensors
- Photoelectric Sensors
- Industrial Vision
- Ultrasonic Sensors
- Rotary Encoders
- Positioning Systems
- Inclination and Acceleration Sensors
- Fieldbus Modules
- AS-Interface
- Identification Systems
- Displays and Signal Processing
- Connectivity

Pepperl+Fuchs Quality

Download our latest policy here:

www.pepperl-fuchs.com/quality

