

# WCS-EIG310

## WCS Interface Module EtherNet/IP

Manual



EtherNet/IP™

Your automation, our passion.

 **PEPPERL+FUCHS**

---

With regard to the supply of products, the current issue of the following document is applicable: The General Terms of Delivery for Products and Services of the Electrical Industry, published by the Central Association of the Electrical Industry (Zentralverband Elektrotechnik und Elektroindustrie (ZVEI) e.V.) in its most recent version as well as the supplementary clause: "Expanded reservation of proprietorship"

#### **Worldwide**

Pepperl+Fuchs Group  
Lilienthalstr. 200  
68307 Mannheim  
Germany  
Phone: +49 621 776 - 0  
E-mail: [info@de.pepperl-fuchs.com](mailto:info@de.pepperl-fuchs.com)

#### **North American Headquarters**

Pepperl+Fuchs Inc.  
1600 Enterprise Parkway  
Twinsburg, Ohio 44087  
USA  
Phone: +1 330 425-3555  
E-mail: [sales@us.pepperl-fuchs.com](mailto:sales@us.pepperl-fuchs.com)

#### **Asia Headquarters**

Pepperl+Fuchs Pte. Ltd.  
P+F Building  
18 Ayer Rajah Crescent  
Singapore 139942  
Phone: +65 6779-9091  
E-mail: [sales@sg.pepperl-fuchs.com](mailto:sales@sg.pepperl-fuchs.com)  
<https://www.pepperl-fuchs.com>

<b>1</b>	<b>Introduction.....</b>	<b>4</b>
1.1	Content of this Document.....	4
1.2	Target Group, Personnel .....	4
1.3	Symbols Used .....	4
<b>2</b>	<b>Product description.....</b>	<b>6</b>
2.1	Use and Application .....	6
2.2	Dimensions.....	6
2.3	Design of the Device.....	7
<b>3</b>	<b>Installation.....</b>	<b>11</b>
3.1	Mounting.....	11
3.2	Electrical Connection .....	12
3.3	Dismounting .....	14
<b>4</b>	<b>Commissioning.....</b>	<b>15</b>
4.1	Introduction.....	15
4.2	Connecting the WCS Read Head.....	15
4.3	Connection to the Network.....	17
4.4	Setting the IP Address and Subnet Screen.....	18
4.5	Network Settings .....	19
<b>5</b>	<b>Communication with WCS read heads .....</b>	<b>21</b>
5.1	Request Byte for Read Heads .....	21
5.2	Data Format for Modules .....	21
<b>6</b>	<b>Appendix .....</b>	<b>23</b>
6.1	Software Tool for RSLogix 5000, V15, and V17 .....	23
6.2	Cable Routing in the RS-485 Bus.....	23
6.3	Data Cable .....	26

# 1 Introduction

## 1.1 Content of this Document

This document contains information required to use the product in the relevant phases of the product life cycle. This may include information on the following:

- Product identification
- Delivery, transport, and storage
- Mounting and installation
- Commissioning and operation
- Maintenance and repair
- Troubleshooting
- Dismounting
- Disposal



---

**Note**

For full information on the product, refer to the further documentation on the Internet at [www.pepperl-fuchs.com](http://www.pepperl-fuchs.com).

---

The documentation comprises the following parts:

- This document
- Datasheet

In addition, the documentation may comprise the following parts, if applicable:

- EU-type examination certificate
- EU declaration of conformity
- Attestation of conformity
- Certificates
- Control drawings
- Instruction manual
- Other documents

## 1.2 Target Group, Personnel

Responsibility for planning, assembly, commissioning, operation, maintenance, and dismounting lies with the plant operator.

Only appropriately trained and qualified personnel may carry out mounting, installation, commissioning, operation, maintenance, and dismounting of the product. The personnel must have read and understood the instruction manual and the further documentation.

Prior to using the product make yourself familiar with it. Read the document carefully.

## 1.3 Symbols Used

This document contains symbols for the identification of warning messages and of informative messages.

### Warning Messages

You will find warning messages, whenever dangers may arise from your actions. It is mandatory that you observe these warning messages for your personal safety and in order to avoid property damage.

Depending on the risk level, the warning messages are displayed in descending order as follows:



---

#### **Danger!**

This symbol indicates an imminent danger.

Non-observance will result in personal injury or death.

---



---

#### **Warning!**

This symbol indicates a possible fault or danger.

Non-observance may cause personal injury or serious property damage.

---



---

#### **Caution!**

This symbol indicates a possible fault.

Non-observance could interrupt the device and any connected systems and plants, or result in their complete failure.

---

### Informative Symbols



---

#### **Note**

This symbol brings important information to your attention.

---



---

#### **Action**

This symbol indicates a paragraph with instructions. You are prompted to perform an action or a sequence of actions.

## 2 Product Description

### 2.1 Use and Application

The **WCS-EIG310** interface module acts as an interface between the WCS read head and the EtherNet/IP controller. Data is transferred between the WCS read head and the interface module via an RS-485 interface. The data from the interface module to the control panel is transferred via the EtherNet/IP protocol.

You can connect a maximum of four WCS read heads of type LS221 (and/or LS121) to one WCS-EIG310 interface module. If you connect several WCS read heads, they must have different addresses. The number of connected WCS read heads is configured in the hardware project settings.

### 2.2 Dimensions

The interface module housing has the following dimensions.

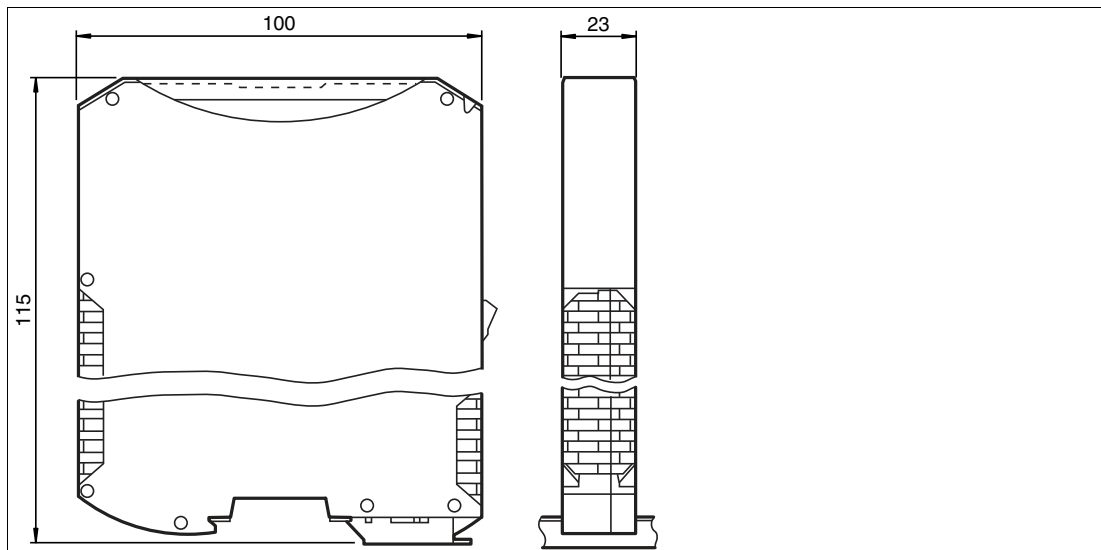

Figure 2.1 Dimensions

## 2.3 Design of the Device

### Device Components

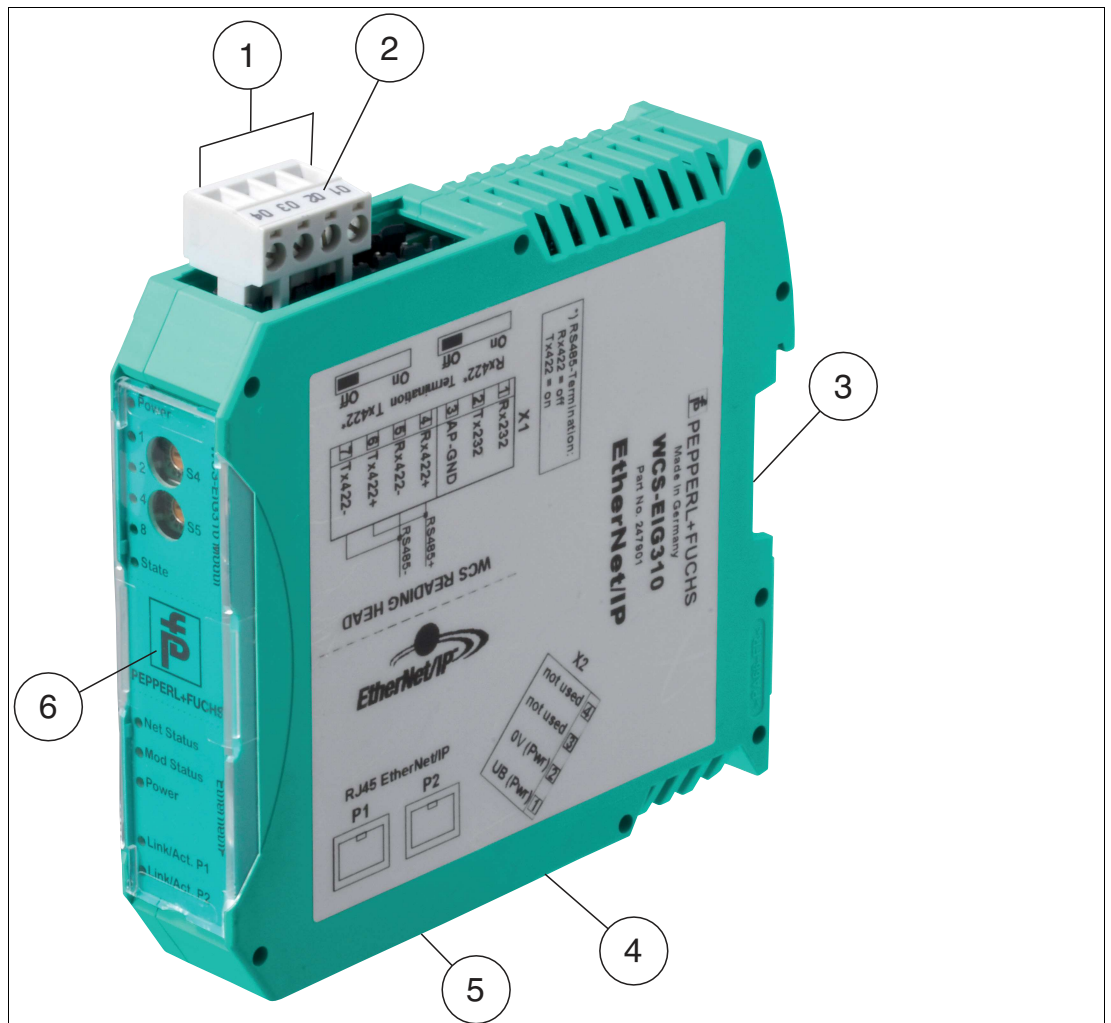

Figure 2.2 Interface module overview

- 1 RS-485 bus termination slide switch
- 2 X1: RS-485 interface
- 3 Mounting bracket
- 4 X2: Connection for power supply
- 5 X3: EtherNet/IP communication interface
- 6 Front panel with rotary coding switch and LED indicator lights

### Front Panel

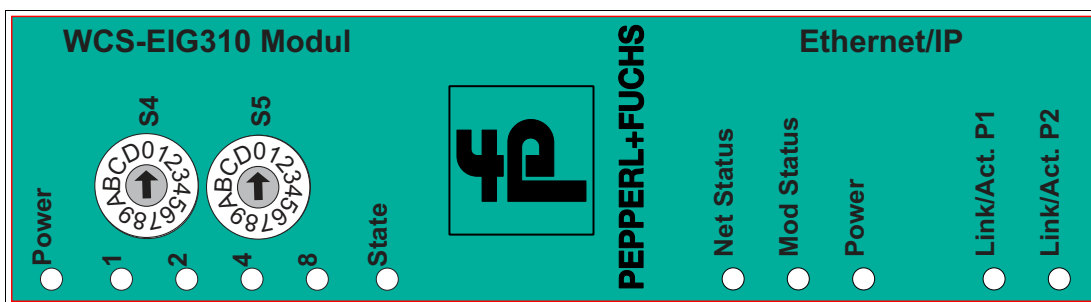

Figure 2.3 Front panel overview

### WCS read head: LED status indicator and rotary coding switch

#### Power:

The "Power" LED lights up green: power supply is present.

#### State:

The "State" LED is green: Data is being exchanged with the WCS read heads. The four "Error No/Select ID" LEDs are used to display the number of the currently polled WCS read head.

Error No/Select ID				Read head address
8	4	2	1	
0	0	0	1	0
0	0	1	0	1
0	1	0	0	2
1	0	0	0	3

Table 2.1 Display via the four "ErrorNo/Select ID" LEDs when the "State" LED lights up green

The "State" LED lights up red: The interface module has detected an error or a warning. The interface module displays the binary coded error and/or warning number via the "Error No/Select ID" LEDs.

- Error (No. 1...5): Switch the interface module off and back on. If the error occurs again, the module must be replaced.
- Warning (No. 6...15): The warning provides information. The interface module displays the warning for one minute and then resets automatically.



LED ErrorNo/Select ID				Error number	Error description
LED8	LED4	LED2	LED1		
0	0	0	0	0	Reserved
0	0	0	1	1	Hardware error
0	0	1	0	2	EEPROM error
0	0	1	1	3	Internal memory error
0	1	0	0	4	Fieldbus hardware error or incorrect fieldbus ID
0	1	0	1	5	Script error
0	1	1	0	6	Reserved
0	1	1	1	7	WCS read head communication, RS send buffer overflow
1	0	0	0	8	WCS read head communication, RS receive buffer overflow
1	0	0	1	9	WCS read head communication, RS timeout
1	0	1	0	10	General fieldbus error
1	0	1	1	11	Parity error or frame check error
1	1	0	0	12	Reserved
1	1	0	1	13	Fieldbus configuration error
1	1	1	0	14	Fieldbus data buffer overflow
1	1	1	1	15	Reserved

Table 2.2 Significance of the error codes (display via the four "Error No/Select ID" LEDs when the "State" LED lights up red and thus indicates an error or a warning)

### Rotary coding switches S4 and S5

The rotary coding switch S4 is used to determine the number of read heads. The rotary coding switch S5 has no function and is always in the "0" switch position.

## EtherNet/IP: LED status indicator

### Net Status:

"Net Status" LED	Interface state
Flashes green/red	Self-test
Lights up green	Connection present, data exchange is active
Flashes green	Waiting for a connection to be established
Flashes red	Connection has timed out
Lights up red	IP address assigned twice

Table 2.3 "Net Status" LED display

### Mod Status:

"Mod Status" LED	Interface state
Flashes green/red	Self-test
Lights up green	Data exchange active
Flashes green	Standby/module waiting for connection
Flashes red	Module error
Lights up red	Serious module error

Table 2.4 "Mod Status" LED display

### Power:

The "Power" LED lights up green: This LED is directly connected to the supply voltage of the serial interface (RS232/422/485).

### Link/Activity P1:

The "Link/Activity Port 1" LED is directly activated by the Ethernet controller and lights up green when the interface module at port 1 is on a working network. When there is data traffic on the network, the LED flashes green at the same speed as the sent/received data.

### Link/Activity P2:

The "Link/Activity Port 2" LED is directly activated by the Ethernet controller and lights up green when the interface module at port 2 is on a working network. When there is data traffic on the network, the LED flashes green at the same speed as the sent/received data.

## 3 Installation

### 3.1 Mounting



#### Mounting the Modules

The module is fastened to a DIN mounting rail with a width of 35 mm using a snap-on fixing method.

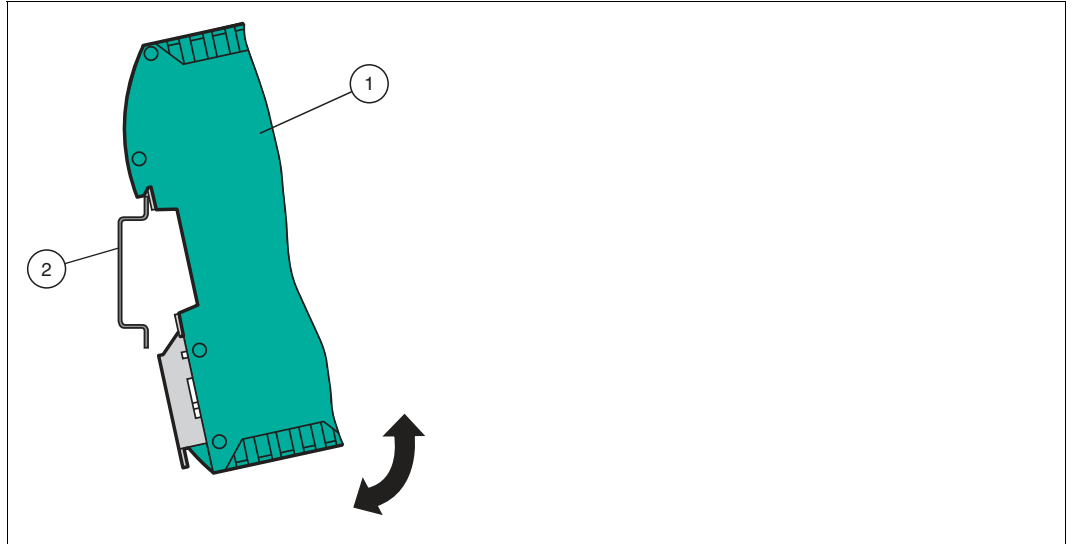

Figure 3.1 Mounting

1. Hook the module (1) onto the DIN mounting rail (2) from above and press it down until it snaps into place.

↳ The module is mounted.



#### Note

##### Heat Dissipation

You may place other modules to the left and right of the module. Above and below the modules, there must be at least 5 cm of free space for heat dissipation.

2. You must connect the DIN mounting rail to the switch cabinet's equipotential busbar. The connection wire must have a cross section of at least 10 mm<sup>2</sup>.



#### Note

##### Vertical Installation

You can also install the DIN mounting rail vertically, so that the modules can be rotated by 90° for mounting.

## 3.2 Electrical Connection



### Danger!

Device damage due to incorrect installation

Incorrect installation of cables and connection lines can endanger the function and the electrical safety of the device.

- Observe the permissible core cross section of the conductor.
- If you are using stranded conductors, crimp the stranded conductors with wire end ferrules.
- Make sure that conductors are insulated all the way up to the terminal.
- Observe the tightening torque for the screws on the terminal. The tightening torque is 0.5 Nm.
- Using an unsuitable tool may damage the screw heads. Use a slot-head screwdriver sized 3.5 x 0.5.
- Connecting an alternating current can damage the device or cause the device to malfunction. Connect the device to direct current (DC).

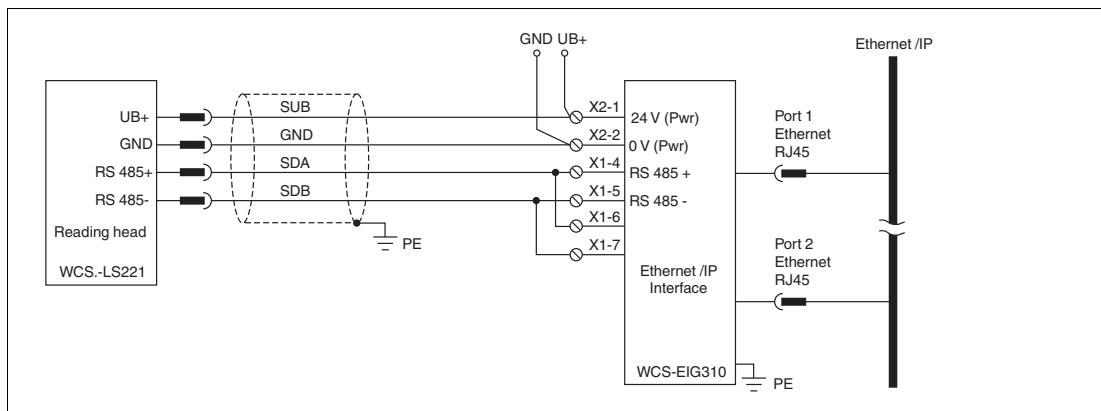

Figure 3.2 Electrical connection

Plug X1 is located on the top side of the interface module, and Plug X2 is located on the underside.

### Connection Technology

You must/may use the following connection technologies when wiring the assembly:

- Standard screw/plug connection (supply + RS)
- 8-pin RJ45 connection (EtherNet/IP connection)

When using standard screw terminals, one cable per connection point can be clamped. To tighten the screws, use a screwdriver with a blade width of 3.5 mm.

Permissible cable cross section:

- Flexible cable with wire end ferrule: 1 x 0.25 ... 1.5 mm<sup>2</sup>
- Solid cable: 1 x 0.25 ... 1.5 mm<sup>2</sup>

The plug-in terminal strip combines a standard screw connection and a plug connector. The plug connector is coded and therefore cannot be plugged in incorrectly.



## Connecting the Power Supply

Connect the operating voltage (10 VDC ... 30 VDC) to terminals 1 and 2 of the 4-pin plug X2 on the interface module. In addition, note the label on the module.

↳ The "Power" LED lights up green.

Terminal		Description
1	UB+ (Pwr)	Operating voltage of interface module/ operating voltage of sensor
2	0 V (Pwr)	Ground of interface module/ground of sensor
3	not used	is not used
4	not used	is not used

Table 3.1 Terminal X2

## Equipotential Bonding Connection

The connection to equipotential bonding occurs automatically when attaching to the DIN mounting rail.



## EtherNet/IP Communication Interface

This interface can be found on the interface module in the form of two 8-pin RJ45 sockets on the bottom of the housing.

Insert the EtherNet/IP connector into one of the RJ45 socket(s) with the inscription "In" (cable from master) or "Out" (further cable to the next EtherNet/IP slave).



### Note

Ensure that the cable length to the neighboring EtherNet/IP participants is at least 0.6 m.



## Preparing for Operation on RS-485 Interface

For operation on an RS-485 interface, the terminals on connector X1 must be connected:

Connect the read head to the terminal. Use the enclosed jumper to connect the terminals to each other

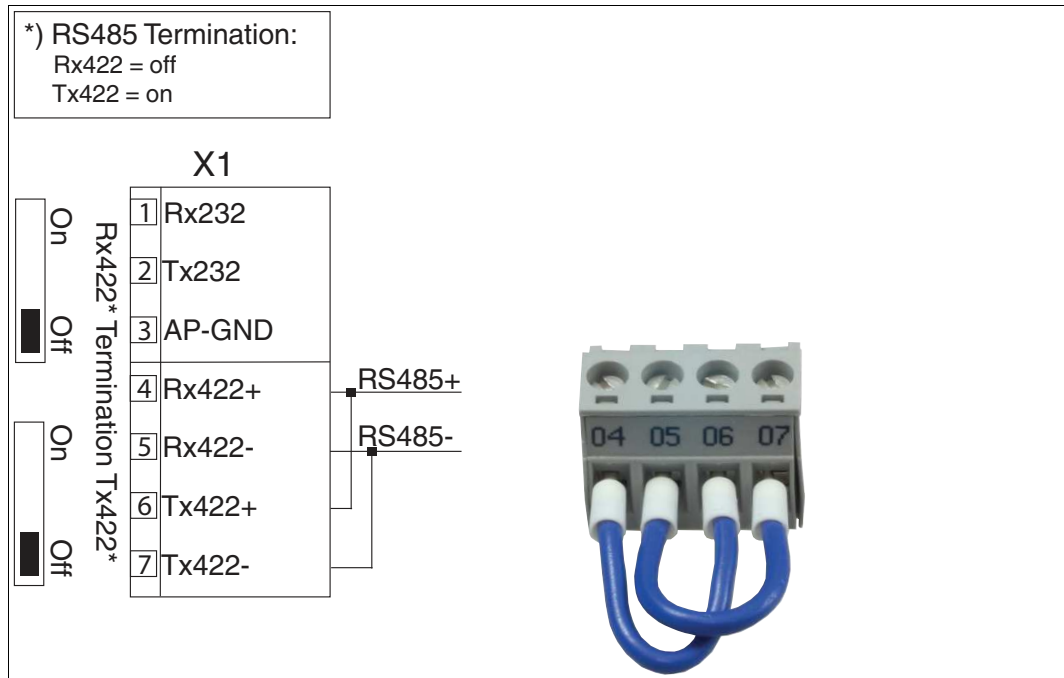

Figure 3.3 Terminal X1

### 3.3 Dismounting



#### Dismounting the modules

Use a suitable slot-head screwdriver for dismounting the module.

1. Disconnect all the supply and signal lines.

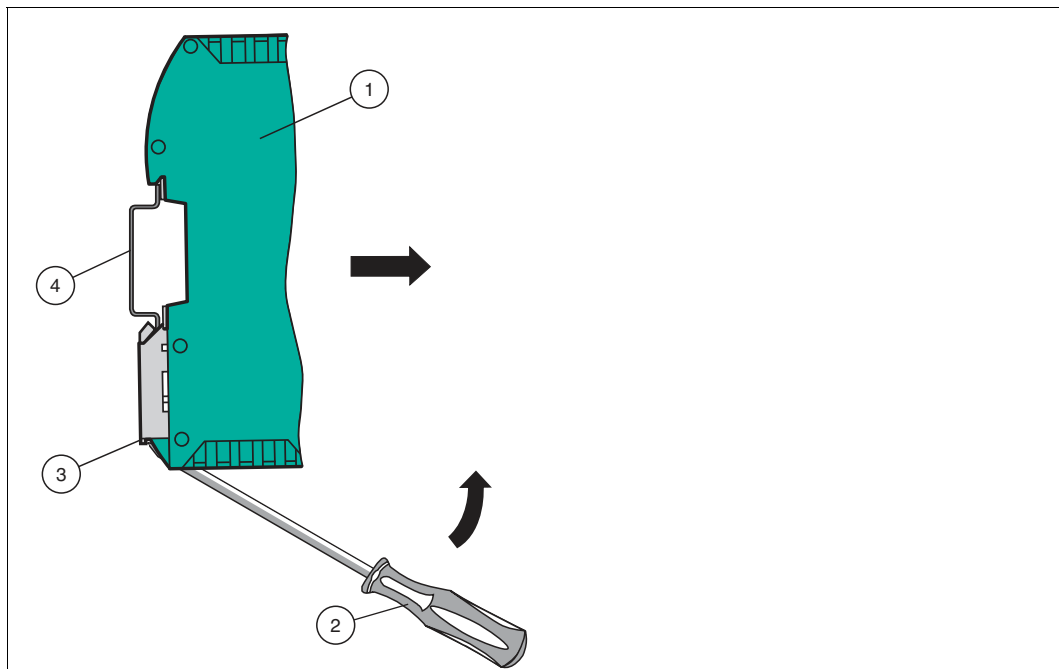

Figure 3.4 Dismounting

2. Insert the screwdriver (2) into the groove of the mounting bracket (3).
3. Press the screwdriver (2) in the specified direction until the lock on the DIN mounting rail (4) opens, see figure.
4. Then press the module (1) upwards and lift it out of the DIN mounting rail.

## 4 Commissioning

### 4.1 Introduction



#### Warning!

Danger to life due to defective work

Errors during installation and commissioning can cause life-threatening injuries and significant property damage.

- Installation and commissioning must only be carried out by trained personnel in accordance with safety regulations.

#### Components

To commission the module, you will require the following components:

- WCS-EIG310 interface module
- EDS file (the EDS file can be obtained free of charge from our website [www.pepperl-fuchs.com](http://www.pepperl-fuchs.com)).
- Cordset from the interface module to the sensor
- Connector for the EtherNet/IP connection to the interface module
- Ethernet cable
- 10 VDC ... 30 VDC voltage supply



#### Downloading the EDS File

You will need an EDS file to operate the module described in this manual. The EDS file must be imported into the corresponding configuration tool before commissioning the module. The EDS file can be downloaded from our website: [www.pepperl-fuchs.com](http://www.pepperl-fuchs.com). Simply enter the product name or item number in the product/keyword field and click the "Search" icon.

1. To access the product detail page for the device, go to <http://www.pepperl-fuchs.com> and enter information about the device (e.g., the product description or the item number) into the search function.
2. Select your product from the list of search results. Click on the information you require in the product information list, e.g., **Software**.

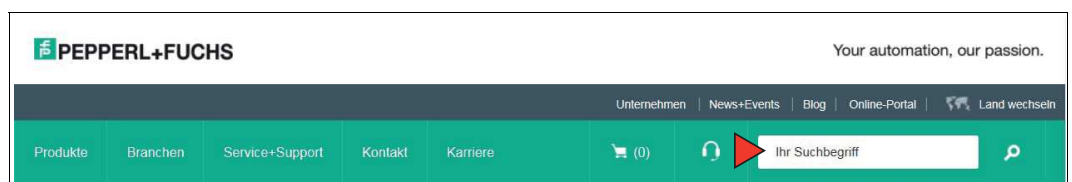

↳ A list of all available downloads is displayed.



## 4.2 Connecting the WCS Read Head

If you connect several WCS read heads to one interface module, the WCS read heads must have different addresses. This will allow the programmable logic controller to allocate the data to the correct WCS read heads. If you only connect one WCS read head to an interface module, this WCS read head always receives the address 0. You can connect up to WCS read heads to an interface module via an RS-485 cable. Each WCS read head is supplied with the default address of 0. Details of how to change the address of the WCS read head can be found in the configuration instructions for the WCS read head.

WCS read head connection pin		Terminal on interface module
WCS2B	WCS3B	
2	1	X2-1
4	2	X1-4
1	4	X1-5
3	3	X2-2

Table 4.1 Connection of WCS read heads

### Setting the Number of Connected WCS Read Heads

Set the number of connected WCS read heads with the rotary switch S4 in accordance with the table "Rotary switch S4."

#### Rotary switch S4

Switch position S4	Number of WCS read heads	Read head address
0	1 WCS read head	0
1	2 WCS read heads	0, 1
2	3 WCS read heads	0, 1, 2
3	4 WCS read heads	0, 1, 2, 3
4	1 WCS read head with velocity output	0
5	2 WCS read heads with velocity output	0, 1
6	3 WCS read heads with velocity output	0, 1, 2
7	4 WCS read heads with velocity output	0, 1, 2, 3

Table 4.2 Position of rotary switch S4 for setting the number of WCS read heads



#### Example

You have connected three read heads to the interface module and want to use the velocity output. Set the rotary switch S4 to switch position 6 and set the addresses 0, 1, 2 on the three read heads.

### Rotary Coding Switch S5

Rotary coding switch S5 has no function. Always set this switch to the "0" switch position.



## Connecting the WCS Read Head

1. Connect the voltage supply for the WCS read head to terminals 1 and 2 of the 4-pin connector X2 on the interface module.
2. Connect the RS-485 data cable to the WCS read head on terminals 4 and 5 of connector X1.



## Activating the RS-485 Bus Termination

If the interface module is operated as the first or last physical device in an RS-485 bus or if you operate one read head on the interface module, a bus termination must be performed on this interface module.

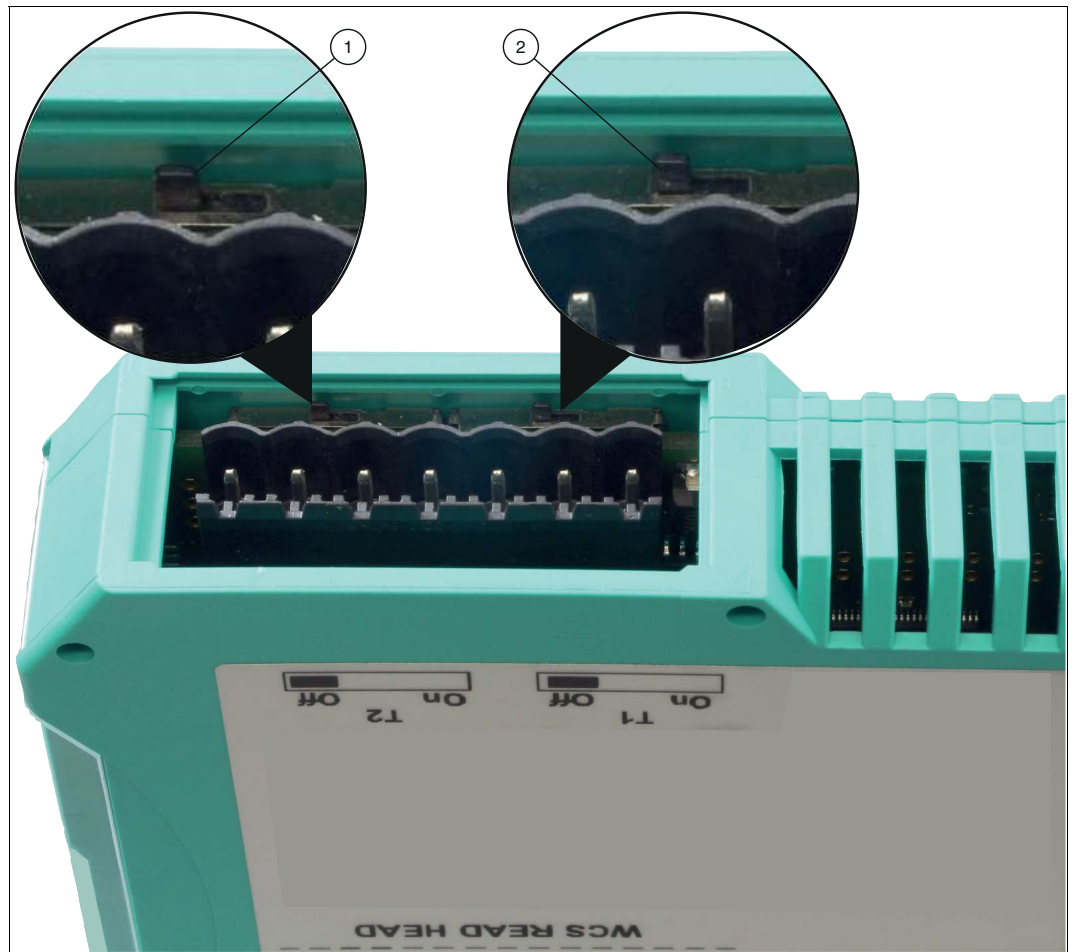

Figure 4.1 RS-485 Bus Termination

Set the T2 slide switch (1) to "On" to activate the bus termination (150  $\Omega$ ).



### Note

The T1 slide switch (2) has no function and remains in the "Off" switch position.

### 4.3 Connection to the Network

The connection to EtherNet/IP is made via the two RJ45 EtherNet/IP P1 and P2 sockets on the underside of the interface module. The front socket is labeled P1 and the rear socket is labeled P2. Connect the device to the EtherNet/IP network at the interface with the label "P1" (cable from master) or "P2" (further cable to the next slave).



#### Note

The cable to the surrounding Ethernet devices must be at least 0.6 m long.

#### Pinout P1 and P2

Terminal		Designation
1	TD+	Transmission line +
2	TD-	Transmission line -
3	RD+	Receive line +
4	n.c.	Not connected
5	n.c.	Not connected
6	RD-	Receive line -
7	n.c.	Not connected
8	n.c.	Not connected

Table 4.3 Terminals of the 8-pin "RJ45 EtherNet/IP" sockets



#### Connecting the Device to the Controller

Plug the Ethernet connector into the RJ45 socket. Use a data cable of at least Category 5.

## 4.4 Setting the IP Address and Subnet Screen

To set the device IP address, the subnet screen, and the gateway IP address, you need the WCS UGC\_PF configuration tool.



### Downloading the Software Tool from the Internet

The software tool can be downloaded from our website: [www.pepperl-fuchs.com](http://www.pepperl-fuchs.com).

1. Simply enter the product name or item number in the Product/Keyword field and click "Search."
2. Select your product from the list of search results.
3. Click on the information you require in the product information list, e.g., Software.

↳ A list of all available downloads is displayed.

### WCS UGC\_PF configuration tool

Unzip the files contained in the ZIP file in a directory of your choice on your computer. Start UGC\_PF.exe and select "Help" from the menu bar. Select "Readme" in the drop-down menu. Here you will find a brief description of the WCS UGC\_PF configuration tool's functions.

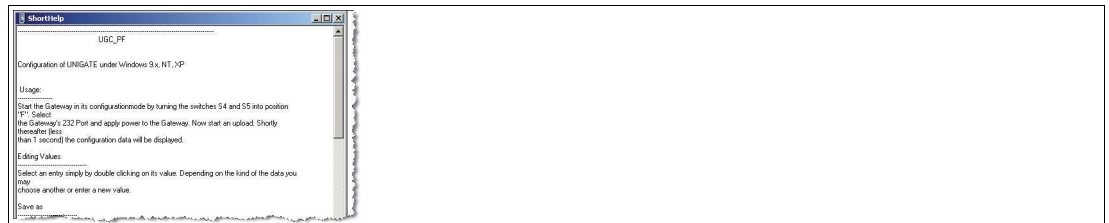

1. Set the two rotary switches S4 and S5 on the front panel of the interface module to position **F**.
2. Establish a connection between the RS-232 interface of the interface module and your PC.
3. Use the **"Upload" function** to load the interface module configuration to the software interface.
4. Select the entry to be edited by double-clicking and edit it. Proceed in the same way with all entries to be changed until the configuration matches your specifications.
5. Save the configuration by clicking **"Safe"** or **"Safe as."**

6. Write the amended configuration into the interface module by clicking "**Download.**"

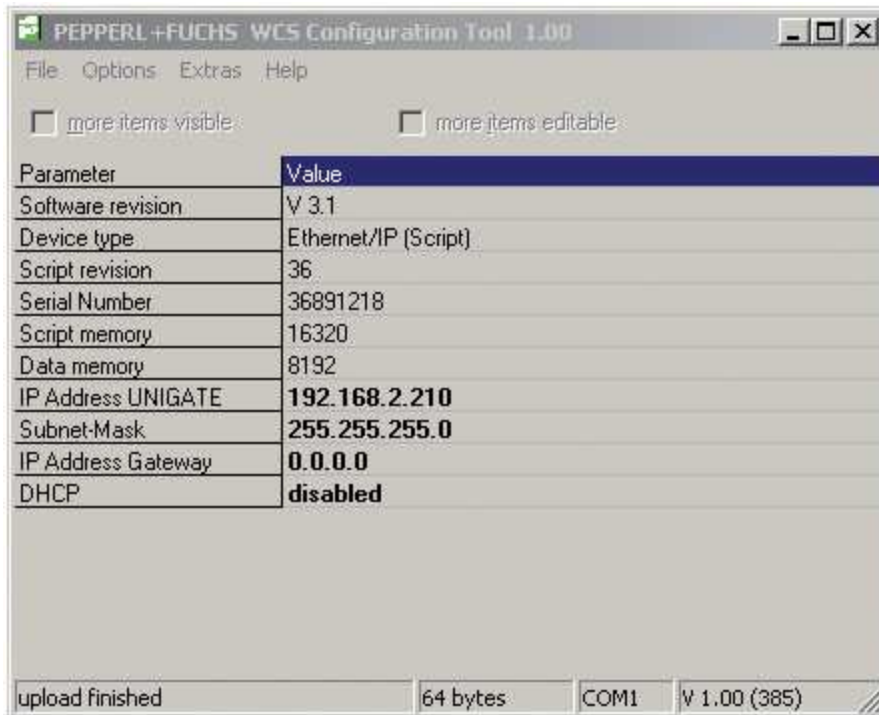

The configuration has now been changed according to your requirements and saved in the non-volatile memory of the interface module.



### Setting Rotary Switches S4 and S5

1. Switch off the interface module.
2. Close the WCS UGC\_PF configuration tool.
3. Disconnect the RS-232 connection between the interface module and the PC.
4. Set the rotary switch S4 to the correct position in accordance with your hardware configuration.
5. Set the rotary switch S5 to the correct position in accordance with your hardware configuration.

↳ The interface module is now ready to use.

## 4.5 Network Settings

The interface modul uses implicit messaging. Therefore, any position and speed data is mapped directly in the controller. The following figure shows the correct setting for integrating the interface module into the network.

Parameters	Value
Input assembly	101
Output assembly	100
Configuration assembly	4
Minimum RPI	20 ms

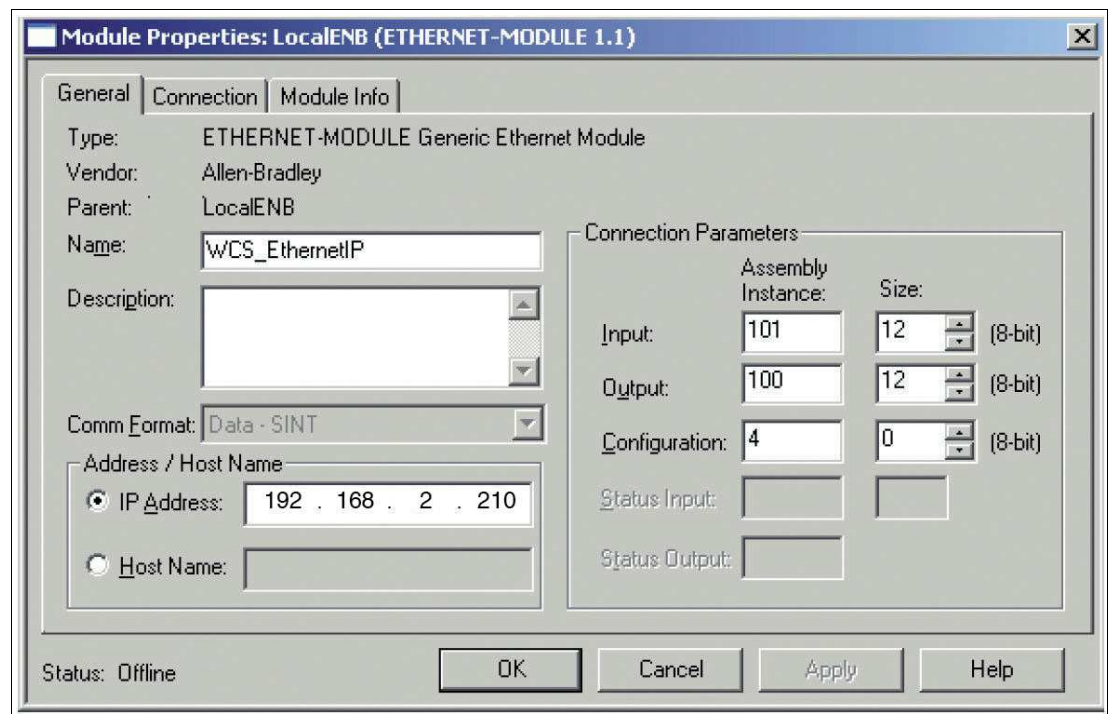

Figure 4.2 Network settings

You can enter all values with the exception of the values for "Input Size" and "Output Size" on the input screen of your project planning tool. The values for "Input Size" and "Output Size" depend on the number of readers and the desired data output. You have to adjust these according to your hardware configuration.

### Values for "Input Size" and "Output Size"

Hardware configuration	"Input Size" and "Output Size"
1 reader	4 bytes
2 readers	8 bytes
3 readers	12 bytes
4 readers	16 bytes
1 reader with velocity output	6 bytes
2 readers with velocity output	12 bytes
3 readers with velocity output	18 bytes
4 readers with velocity output	24 bytes

### Example:

You have connected three readers to the interface module and want to use the velocity output. Enter the value 18 in both fields "Input Size" and "Output Size".

## 5 Communication with WCS read heads

### 5.1 Request Byte for Read Heads

	Read head address 3		Read head address 2		Read head address 1		Read head address 0	
Bit	7	6	5	4	3	2	1	0
	0	F0	0	F0	0	F0	0	F0

F0=0: The read head sends the position data to the interface module. This standard function is automatically active after commissioning.

F0=1: The read head sends the results of the diagnostic function.

### 5.2 Data Format for Modules

In "only Position" operating mode, 4 bytes are reserved for each WCS reader.

Bit	7	6	5	4	3	2	1	0
Byte 0	0	0	0	0	0	P18	P17	P16
Byte 1	P15	P14	P13	P12	P11	P10	P09	P08
Byte 2	P07	P06	P05	P04	P03	P02	P01	P00
Byte 3	0	0	0	DB	ERR	OUT	A1	A0

Table 5.1 Data format for each connected WCS reader in "only Position" operating mode, reader address = 0...3

In "Position and Speed" operating mode, 6 bytes are reserved for each WCS reader.

Bit	7	6	5	4	3	2	1	0
Byte 0	0	0	0	0	0	P18	P17	P16
Byte 1	P15	P14	P13	P12	P11	P10	P09	P08
Byte 2	P07	P06	P05	P04	P03	P02	P01	P00
Byte 3	0	0	0	DB	ERR	OUT	A1	A0
Byte 4	0	0	0	0	0	0	0	0
Byte 5	0	S06	S05	S04	S03	S02	S01	S00

Table 5.2 Data format for each connected WCS reader in "Position and Speed" operating mode, reader address = 0...3

Pxx: position data, P00 = LSB

Sxx: speed (in multiples of 0.1 m/s), S00 = LSB

Example: Byte 5 = 00011011 = 27, corresponds to 2.7 m/s

A1, A0: reader address, 00 = WCS reader address #1

DB: pollution display, 1 = cleaning necessary

OUT: code rail loss, 0 = code rail recognized

ERR: error display, error code (LEDs)



**Address bits A1 and A0**

A1	A0	Reader address
0	0	Reader address 0
0	1	Reader address 1
1	0	Reader address 2
1	1	Reader address 3

**Status bits**

DB	ERR	OUT	Description	Optical state of WCS reader
0	0	0	Current position value binary coded in P00...P18	Good
0	0	1	WCS reader outside of the code rail, not a position value	Good
			P0...P18=0: WCS reader partly outside the code rail	
			P0=1, P2...P18=0: WCS reader completely outside of the code rail	
1	0	0	Current position value binary coded in P00...P18	Poor
1	0	1	No position value, WCS reader outside of the code rail	Poor
X	1	X	No position value, error message from WCS reader, error number binary coded in P00...P18	-

## 6 Appendix

### 6.1 Software Tool for RSLogix 5000, V15, and V17

This small tool divides the 4 or 6 byte long messages of each WCS read head into the position values, the speed values, and diagnostic information.

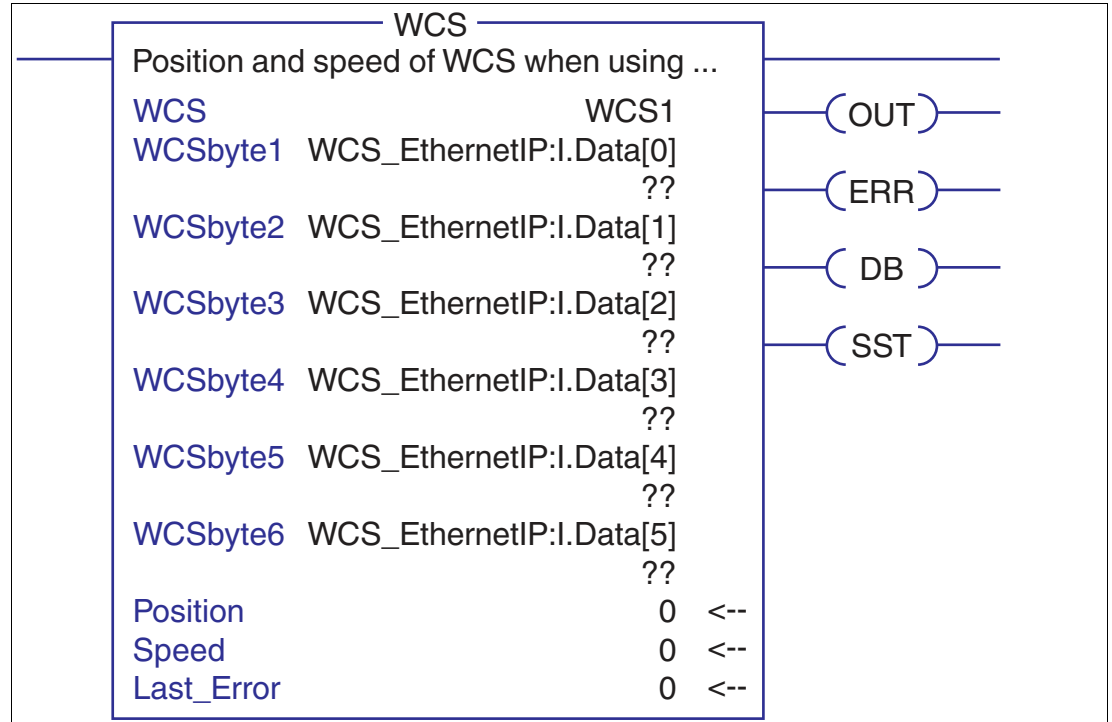

- Position: position data of the read head
- Speed: speed of the read head = speed value x 0.1 m/s
- Last Error: If an error bit is active, it will appear here. It can be reset by the user.
- SST: Status bit speed, usually "0". "1" when an invalid speed value occurs.
- Out: Code rail outside of read head range.
- ERR: An error has occurred. Check "Last Error" for details
- DB: dirty lens system. Please clean the scanning system with a soft, damp cloth without cleaning additives.

## 6.2 Cable Routing in the RS-485 Bus

The data cables must always form an in-line connection between the first and the last node. This in-line connection must end with a terminator.

The RS-485 terminators are integrated in the WCS readers and can be switched on and off with the interface module.

If only **one WCS reader** is connected, one device is connected at the beginning and one device is connected at the end of the data line.

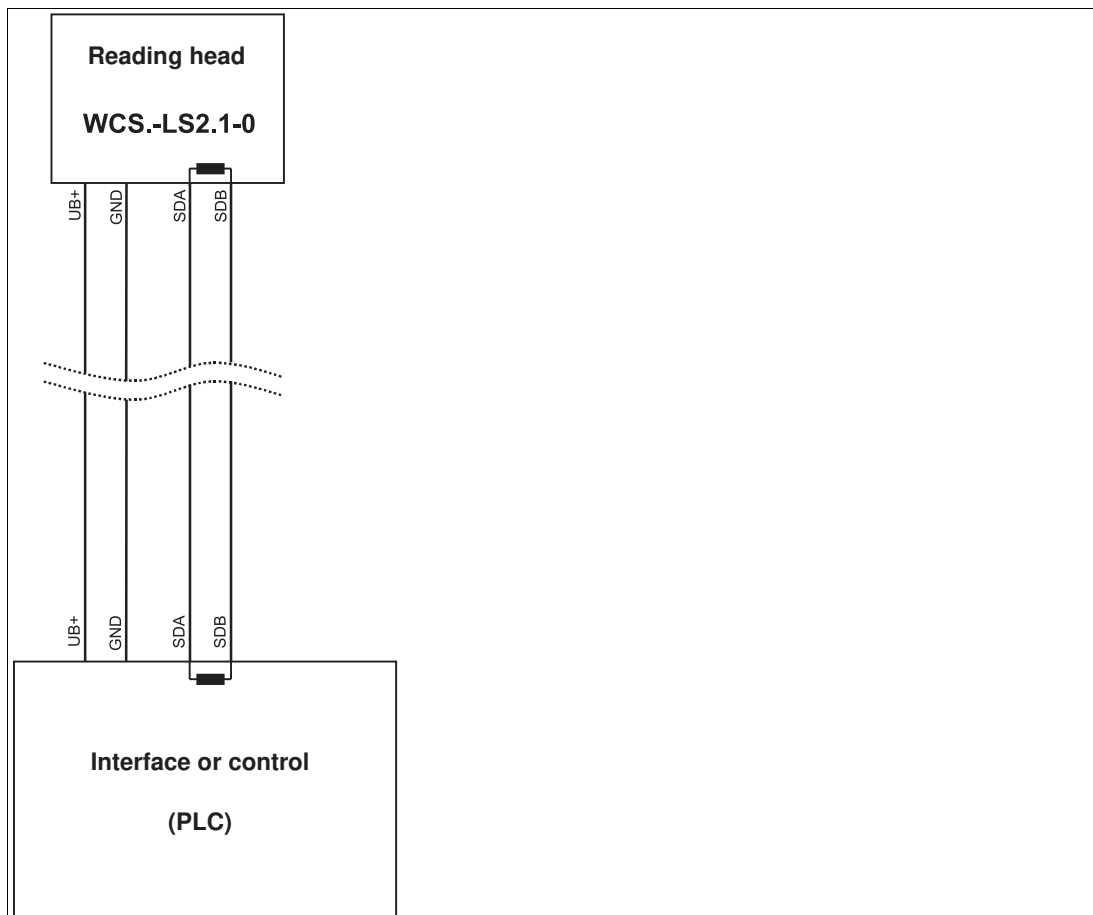

Figure 6.1 Connection of **one** reading head

If **two WCS readers** are connected to one interface module, there are two wiring versions:

- **Version A:**

One WCS reader is located at the beginning and one WCS reader at the end of the data line. For both WCS readers, the RS-485 terminator is activated. The interface module is located between these two readers and does not have an RS-485 terminator. Each WCS reader is connected to the interface module by a separate data cable.

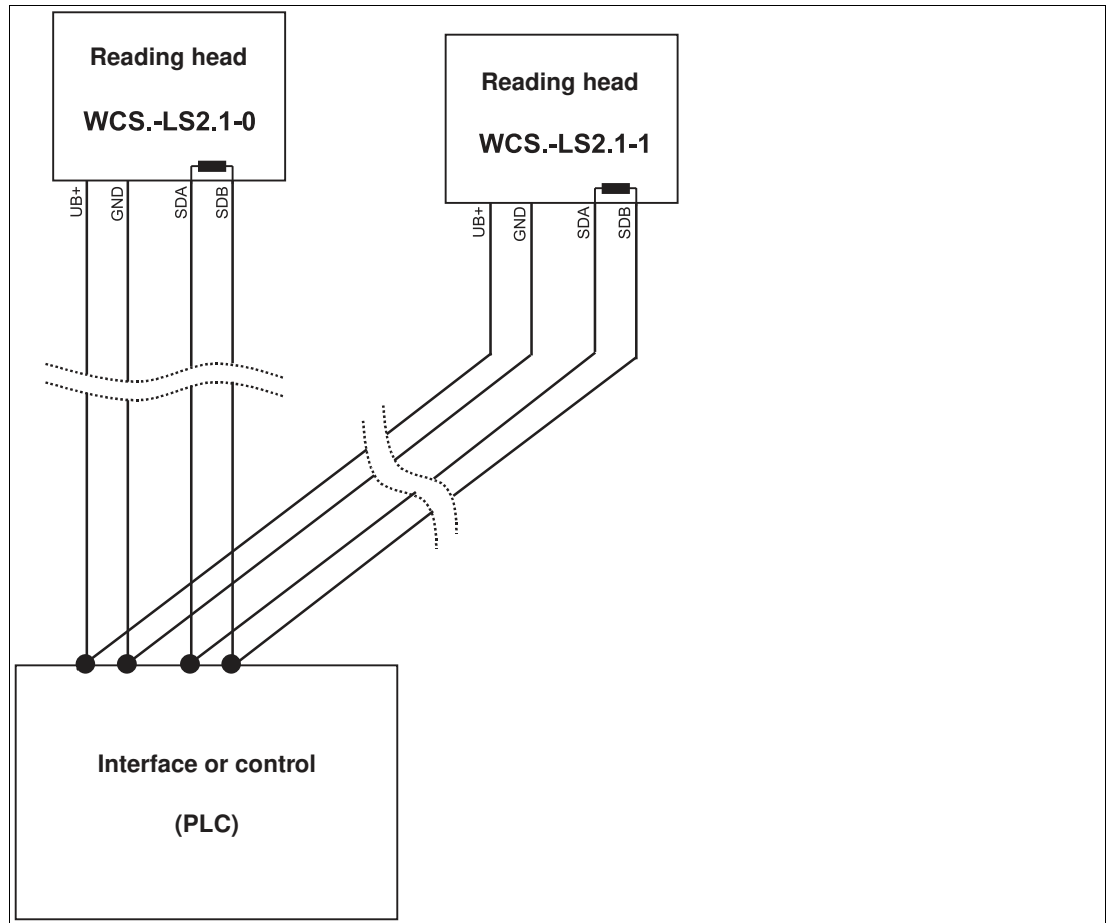

Figure 6.2 Connection of **two** reading heads, Version A

- **Version B:**

The interface module is located at the beginning of the data line; one WCS reader is located at the end of the data line. Both need the RS-485 terminator. The second WCS reader is connected to the line connection between the interface module and the first WCS reader through a short spur (length <1 m). Use a bus terminal to connect the spur.

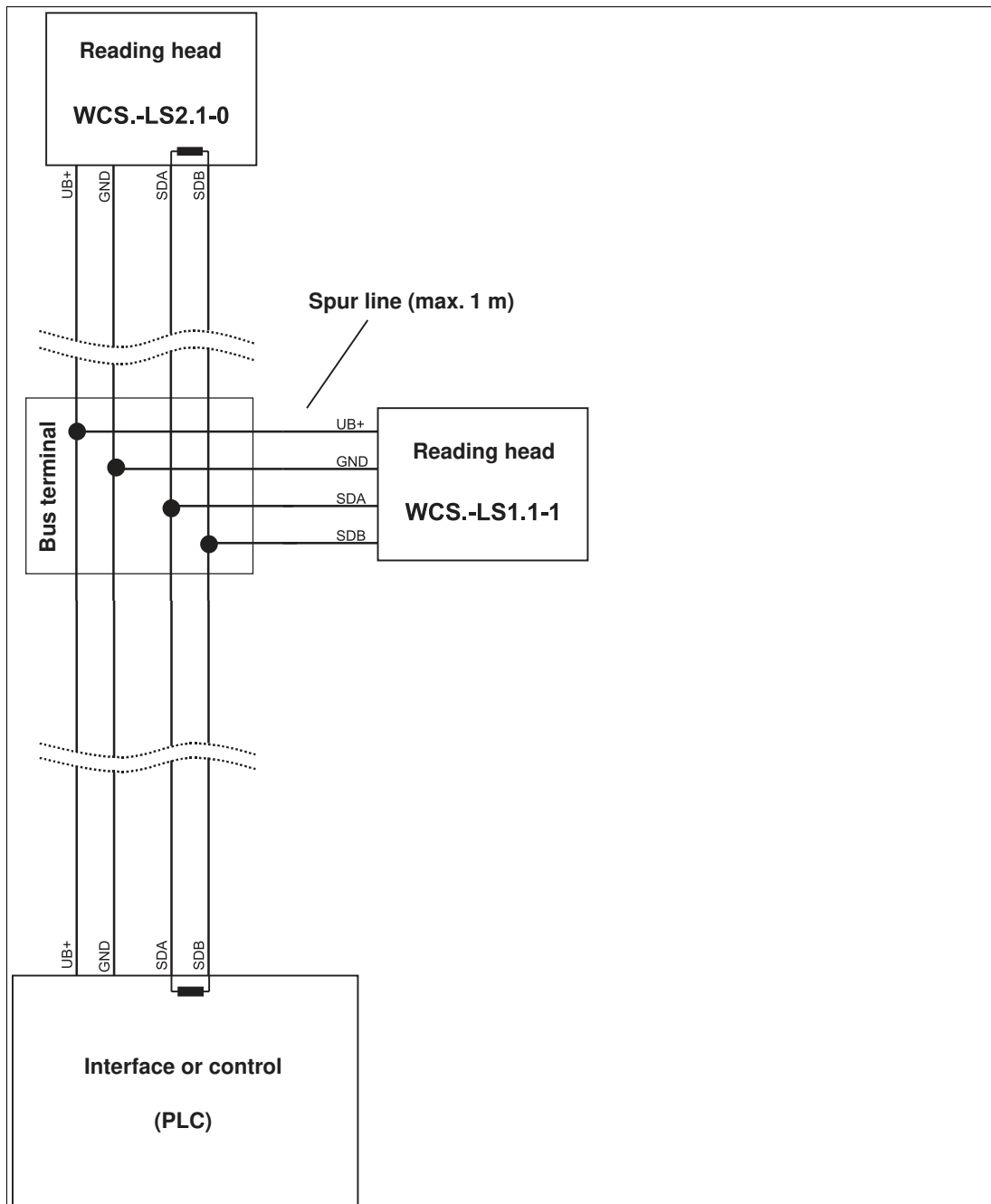

Figure 6.3 Connection of **two** reading heads, Version B

The wiring version used depends on which is best suited for the application. If **three** or **four WCS readers** are used on the same interface module, connect these using spurs as shown in variant B.

## 6.3 Data Cable

A shielded data cable with twisted-pair cores is used for the electrical connection. Pepperl+Fuchs can supply suitable preassembled M12 single-ended female cordsets ( ) or field-attachable M12 female connectors and data cables.

### Data Cable WCS-DC\*

There are two types of data cable available:

- **WCS-DCS** for stationary cable routing
- **WCS-DCF** for routing trailing cables and drag chains.

The data cables are twisted pairs and have a tinned copper braided shield. The braided shield surrounds all wire pairs. The parameters of the data cables suitable for RS-485, SSI, and CANopen data transfer are listed in the table below.

	WCS-DCS	WCS-DCF
Capacitance (core-core)	120 pF/m	60 pF/m
Cross section	0.14 mm <sup>2</sup>	0.25 mm <sup>2</sup>
Number of cores	6 (3 x 2)	6 (3 x 2)
External diameter	5.8 mm	7.5 mm
Temperature range	-40 ... 80 °C	-40 ... 70 °C

### Cable Routing

The basic prerequisite for uninterrupted data transfer is that the data cables are routed in such a way that any coupling of electromagnetic fields and interference is excluded. For EMC-compliant cable routing, it is necessary to divide the cables into cable groups and route these groups separately.

#### Group A

- Shielded data cable (including analog)
- Unshielded cable for DC and AC voltages 0 ... 60 V
- Shielded cable for DC and AC voltages 0 ... 230 V
- Coaxial cables for monitors

#### Group B

- Unshielded cable for DC and AC voltages 60 ... 400 V

#### Group C

- Unshielded cable for DC and AC voltages greater than 400 V

### Shielding Cables

The shielding of cables is required to suppress electromagnetic interference. Establishing a low resistance or low impedance connection with the protective conductor is a particularly important factor in ensuring that these interference currents do not become a source of interference themselves.

The WCSB2B and WCS3B read heads have no connection option for the cable shield. The cable shield is connected to the plant potential in the switch cabinet with low resistance (large area). In the case of high electromagnetic interference, it is advisable to connect the shield of the data cable to the plant potential in the immediate vicinity of the read head with low resistance using a grounding clip.

## Cable Length

For the RS-485 data transfer path, a four-wire, shielded, twisted pair data cable must be used. One core pair is used for the supply voltage, and one pair for the RS-485 data connection. The maximum length of the cable depends on the capacitance of the data cable—core-core—for data transfer, and on the cross section of the cables for voltage supply to the read heads. For data transfer, a small core cross section and thus a small cable capacitance is an advantage, whereas for the voltage supply, the largest possible cross section is required. The table below shows the possible cable lengths depending on the cable cross section.

Cable cross section	AWG <sup>1</sup>	Number of read heads without heater				Number of read heads with heater			
		1	2	3	4	1	2	3	4
0.14 mm <sup>2</sup>	~ 26	200 m	110 m	70 m	50 m	15 m	10 m	7 m	5 m
0.22 mm <sup>2</sup>	~ 24	320 m	170 m	110 m	80 m	30 m	15 m	10 m	7 m
0.25 mm <sup>2</sup>	-	350 m	190 m	130 m	90 m	35 m	17 m	12 m	8 m
0.28 mm <sup>2</sup>	-	400 m	220 m	150 m	110 m	40 m	20 m	15 m	10 m
0.34 mm <sup>2</sup>	~ 22	500 m	250 m	180 m	140 m	50 m	25 m	17 m	12 m
0.50 mm <sup>2</sup>	~ 20	500 m	400 m	270 m	200 m	70 m	35 m	25 m	17 m

1. American Wire Gauge, a system commonly used in North America for the specification of wire diameters in electrical engineering.

In the calculations, the worst-case scenario was assumed: All read heads are located at the end of the data cable. In the case of large cable lengths, and when connecting multiple WCS2 read heads with a heater, 6-wire data cables (3 x 2) can be used. These data cables use two pairs for the voltage supply (doubling the cable cross section), and one pair for the RS-485 data line. The table below shows the possible cable lengths depending on the cable capacitance (core-core). The number of connected read heads is of no significance.

Capacitance (core-core)	RS-485 interface		
	19.2 kb	62.5 kb	187.5 kb
60 pF	500 m	500 m	300 m
90 pF	500 m	450 m	275 m
120 pF	500 m	400 m	250 m

## Cable Overview

The cable types listed below represent a selection of the types available from Pepperl+Fuchs. You can find additional cable types on our website.



### Note

For customizable cables, observe the cable length restrictions specified by the interface specifications. Refer to the relevant interface chapters for maximum cable length recommendations.

### RS-485 (LS1xx\*, LS2xx\*)

Cable	Description
<b>Field attachable cable</b>	
V15-G-2M-PUR-ABG	M12 single-ended female cordset, 5-pin, straight, 2 m PUR cable, shielded
V15-G-5M-PUR-ABG	M12 single-ended female cordset, 5-pin, straight, 5 m PUR cable, shielded
V15-G-10M-PUR-ABG	M12 single-ended female cordset, 5-pin, straight, 10 m PUR cable, shielded
<b>Field attachable single-ended female cordsets and available by the meter</b>	
V15-G-ABG-PG9	M12 single-ended female cordset, 5-pin, straight, field attachable, shielded
V15-G-ABG-PG9-FE	M12 single-ended female cordset, 5-pin, straight, field attachable, shielded with grounding terminal
V15-G-PG9	M12 single-ended female cordset, 5-pin, straight, field attachable
V15-W-PG9	M12 single-ended female cordset, 5-pin, angled, field attachable
WCS-DCS	Available by the meter, 6-pin data cable + shield, 0.14 mm <sup>2</sup> 3 x 2 twisted core pair
WCS-DCF	Available by the meter, 6-pin data cable + shield, 0.25 mm <sup>2</sup> 3 x 2 twisted core-pair, suitable for drag chains



# Your automation, our passion.

## Explosion Protection

- Intrinsic Safety Barriers
- Signal Conditioners
- FieldConnex® Fieldbus
- Remote I/O Systems
- Electrical Ex Equipment
- Purge and Pressurization
- Industrial HMI
- Mobile Computing and Communications
- HART Interface Solutions
- Surge Protection
- Wireless Solutions
- Level Measurement

## Industrial Sensors

- Proximity Sensors
- Photoelectric Sensors
- Industrial Vision
- Ultrasonic Sensors
- Rotary Encoders
- Positioning Systems
- Inclination and Acceleration Sensors
- Fieldbus Modules
- AS-Interface
- Identification Systems
- Displays and Signal Processing
- Connectivity

### Pepperl+Fuchs Quality

Download our latest policy here:

[www.pepperl-fuchs.com/quality](http://www.pepperl-fuchs.com/quality)

