

MANUAL

IO-Link master

ICE3-8IOL-G65L-V1D

ICE3-8IOL-K45P-RJ45

ICE3-8IOL-K45S-RJ45

ICE3-8IOL1-G65L-V1D

Fieldbus Module with
PROFINET IO, Modbus/TCP
and IO-Link



With regard to the supply of products, the current issue of the following document is applicable: The General Terms of Delivery for Products and Services of the Electrical Industry, published by the Central Association of the Electrical Industry (Zentralverband Elektrotechnik und Elektroindustrie (ZVEI) e.V.) in its most recent version as well as the supplementary clause: "Expanded reservation of proprietorship".

Table of Contents

1. Introduction	8
1.1. Installation and Configuration Overview	8
1.2. Locating the Latest Software and Documentation	9
2. Hardware Installation	10
2.1. ICE3-8IOL-G65L-V1D Hardware Installation	10
2.1.1. Setting the Rotary Switch	10
2.1.2. Connecting to the Network	12
2.1.3. Connecting the Power	12
2.1.4. Mounting the ICE3-8IOL-G65L-V1D.....	14
2.2. ICE3-8IOL1-G65L-V1D Hardware Installation	15
2.2.1. Setting the Rotary Switch	15
2.2.2. Connecting to the Network	17
2.2.3. Connecting the Power	17
2.2.4. Mounting the ICE3-8IOL1-G65L-V1D.....	19
2.3. ICE3-8IOL-K45P-RJ45 Hardware Installation	20
2.3.1. Connecting to the Network	20
2.3.2. Connecting the Power	21
2.3.3. Mounting	22
2.4. ICE3-8IOL-K45S-RJ45 Hardware Installation	23
2.4.1. Connecting to the Network	23
2.4.2. Connecting the Power	24
2.4.3. Mounting	25
3. Configuring the IO-Link master with STEP 7 or TIA Portal	26
3.1. Overview	26
3.2. Installing the GSD File	26
3.3. Configuring the IO-Link master	27
3.3.1. STEP 7 V5.5.....	27
3.3.2. TIA Portal V13	28
3.4. IP Address Assignment	28
3.4.1. Assigning an IP Address via IO Controller (DCP)	28
3.4.1.1. STEP 7 V5.5.....	29
3.4.1.2. TIA Portal V13.....	30
3.4.2. Assigning an IP Address via DHCP	31
3.4.3. Assigning an IP Address Statically (LOCAL)	33
3.4.3.1. STEP 7 V5.5.....	33
3.4.3.2. TIA Portal V13.....	35
3.4.3.3. Assign IP Address Statically Using the Web Page	37
3.5. Device Name Assignment	39
3.5.1. Assign the Device Name in STEP 7.....	39
3.5.1.1. STEP 7 V5.5.....	39
3.5.1.2. TIA Portal V13.....	40
3.5.2. Using the Web Interface to Assign the Device Name	40
3.6. Setting the IO Device Update Time	42
3.6.1. STEP 7 V5.5.....	42
3.6.2. TIA Portal V13	43

3.7. Configuring IO-Link Ports	44
3.7.1. IO-Link Port Modules	45
3.7.1.1. IO-Link Port Settings (IO-Link Port Module Parameters).....	46
3.7.1.1.1. STEP 7 V5.5	47
3.7.1.1.2. TIA Portal V13.....	48
3.7.1.2. SIO Digital In/Out Module Parameters	49
3.7.1.2.1. STEP 7 V5.5	49
3.7.1.2.2. TIA Portal V13.....	50
3.7.2. IO-Link Device Modules	50
3.7.2.1. STEP 7 V5.5	51
3.7.2.2. TIA Portal V13.....	52
3.7.3. Port Status Modules	53
3.7.3.1. IO-Link Status Module	53
3.7.3.2. Auxiliary Input Parameters	54
3.7.3.2.1. STEP 7 V5.5	55
3.7.3.2.2. TIA Portal V13.....	56
3.7.3.3. IO-Link Power Module (ICE3-8IOL1-G65L-V1D)	56
3.7.3.3.1. Configuring IO-Link Power Parameters.....	58
3.7.4. Configuring IO-Link Ports with the Web Interface	59
3.8. Configuring other Settings and Diagnosis	64
3.8.1. Configuring OPC UA Settings.....	64
3.8.1.1. STEP 7 V5.5	64
3.8.1.2. TIA Portal V13.....	64
3.8.2. Configuring Diagnosis Settings.....	65
3.8.2.1. STEP 7 V5.5	66
3.8.2.2. TIA Portal V13.....	67
4. Updating Images and Applications	68
4.1. Images and Application Sub-Assemblies Overview	68
4.1.1. Images.....	69
4.1.2. Application Sub-assemblies	70
4.2. Using the Web Interface to Update Software	71
4.2.1. Updating Images	71
4.2.2. Updating Application Subassemblies	72
5. Connecting Devices	73
5.1. Overview.....	73
5.2. ICE3-8IOL-G65L-V1D IO-Link Ports	74
5.3. ICE3-8IOL1-G65L-V1D IO-Link Ports	76
5.4. ICE3-8IOL-K45P-RJ45 IO-Link Ports.....	78
5.5. ICE3-8IOL-K45S-RJ45 IO-Link Ports.....	79
6. IO-Link Port Configuration	81
6.1. Preparing for Port Configuration	81
6.2. IO-Link Configuration Page.....	84
6.2.1. Editing IO-Link Port Settings.....	84
6.2.2. IO-Link Settings Parameters.....	86
6.3. PROFINET IO Settings Configuration Page.....	89
6.4. Modbus/TCP Settings Configuration Page.....	90
6.4.1. Editing Modbus/TCP Settings.....	90
6.4.2. Modbus/TCP Settings Parameters	92



- 6.5. OPC UA Settings Configuration Page 96**
 - 6.5.1. Edit OPC UA Settings..... 97
 - 6.5.2. OPC UA Settings Parameters 97
- 6.6. MQTT Settings Configuration Page..... 99**
 - 6.6.1. MQTT Settings Page..... 100
 - 6.6.2. Configuring MQTT..... 101
- 7. Loading and Managing IODD Files 102**
 - 7.1. IO-Link Device Description Files Page 102**
 - 7.1.1. Locating IODD Files Using IODD Finder 103
 - 7.1.2. Preparing IODD Files to Upload 104
 - 7.1.3. Uploading IODD Zip Files..... 105
 - 7.1.4. Uploading Specific .XML Files or Supporting Files..... 107
 - 7.1.5. Viewing IODD Files 109
 - 7.1.6. Deleting IODD Files..... 110
 - 7.2. IO-Link Device Configuration Summary Page 111**
- 8. Configuring IO-Link Devices 112**
 - 8.1. Port Pages Overview 112**
 - 8.2. Editing Parameters - IO-Link Device - Port Table 116**
 - 8.3. Resetting IO-Link Device Parameters to Factory Defaults 118**
 - 8.4. Editing Parameters - IO-Link Device ISDU Interface - Port..... 119**
 - 8.4.1. Overview 120
- 9. Utilizing IO-Link master Features 121**
 - 9.1. Setting User Accounts and Passwords 121**
 - 9.2. Data Storage..... 124**
 - 9.2.1. Uploading Data Storage to the IO-Link master 124
 - 9.2.2. Downloading Data Storage to the IO-Link Device 124
 - 9.2.3. Automatic Device Configuration 125
 - 9.2.4. Automatic Device Configuration Backup 127
 - 9.3. Device Validation 128**
 - 9.4. Data Validation 129**
 - 9.5. IO-Link master Configuration Files 130**
 - 9.5.1. Saving Configuration Files..... 130
 - 9.5.2. Loading Configuration Files..... 131
 - 9.6. Configuring Miscellaneous Settings..... 132**
 - 9.6.1. Using the Menu Bar Hover Shows Submenu Option 133
 - 9.6.2. Enable PDO Write From Attached Devices Port Page..... 133
 - 9.6.3. IO-Link Test Event Generator 134
 - 9.7. Clearing Settings..... 137**
- 10. Using the Diagnostics Pages 138**
 - 10.1. IO-Link Port Diagnostics 138**
 - 10.2. PROFINET IO Diagnostics Page 142**
 - 10.3. Modbus/TCP Diagnostics..... 146**
 - 10.4. OPC UA Diagnostics Page 149**
 - 10.5. MQTT Diagnostics Page..... 150**
 - 10.6. Power Diagnostics Page (ICE3-8IOL1-G65L-V1D Only)..... 152**

11. PROFINET IO Reference Information	154
11.1. Sample IO-Link master Gateway Configuration	154
11.2. Available Record Data	156
11.2.1. PDI as Record Data	156
11.2.2. IO-Link Device Information as Record Data	156
11.2.3. Using the SFB52 RDREC	157
11.3. Read and Write ISDU with the FB IOL_CALL	158
11.3.1. Using the IO-Link Library In the TIA Portal	159
11.4. Diagnostic Alarm	163
11.4.1. IO-Link Event Mapping Overview	163
11.4.2. IO-Link EventCode Mapping	163
12. Modbus/TCP Interface	166
12.1. Overview	166
12.2. Modbus Function Codes	168
12.3. Modbus Address Definitions	168
12.4. Multiple Port Process Data (PDI/PDO) Access via Modbus/TCP	171
12.5. Modbus Read/Write Example	173
12.5.1. Modbus Configuration Data	173
13. Functionality Descriptions	177
13.1. Process Data Block Descriptions	177
13.1.1. Input Process Data Block Description	178
13.1.1.1. Input Process Data Block-16 Bit Data Format	179
13.1.2. Output Process Data Block Description	180
13.1.2.1. Output Process Data Block-16 Bit (INT) Data Format	180
13.2. Event Handling	181
13.2.1. Clear Event After Hold Time Process	182
13.2.2. Clear Event in PDO Block Process	183
13.2.3. Clear Event Code in PDO Block and Clear Event After Hold Time Process-PDO Block First	184
13.2.4. Clear Event Code in PDO Block and Clear Event After Hold Time Process-Hold Time Expires	185
13.3. ISDU Handling	186
13.3.1. ISDU Request/Response Structure	186
13.3.1.1. Single ISDU Command Request	186
13.3.1.2. Multiple ISDU Command Structure	187
13.3.2. ISDU Request Message Format-From PLC to IO-Link master	189
13.3.2.1. Standard ISDU Request Command Format	189
13.3.2.2. Integer (16-Bit Word) ISDU Request Command Format	190
13.3.3. ISDU Response Message Format	191
13.3.3.1. Standard ISDU Response Command Format	191
13.3.3.2. Integer (16-Bit Word) ISDU Response Command Format	192
13.3.4. ISDU Blocking and Non-Blocking Methods	193
13.3.4.1. Single Command Blocking	193
13.3.4.2. Multiple Command Blocking	194
13.3.4.3. Single Command Non-Blocking	195
13.3.4.4. Multiple Command Non-Blocking	196
14. OPC UA	197
14.1. OPC UA Server	197
14.1.1. PDI Data	199
14.1.2. PDO Data	199
14.2. Data Models	200
14.3. Functions	203



15. MQTT	204
15.1. Overview	204
15.2. Process Data Publish Interval	205
15.3. Topics and Payloads	206
15.4. ISDU Read/Write.....	209
15.5. ISDU Request Payload	210
15.6. ISDU Response Payload	210
15.7. PDO Write	212
16. Troubleshooting	217
16.1. Troubleshooting.....	217
16.2. IO-Link master LEDs.....	218
16.2.1. ICE3-8IOL-G65L-V1D LEDs.....	218
16.2.2. ICE3-8IOL1-G65L-V1D LEDs.....	220
16.2.3. ICE3-8IOL-K45P-RJ45 LEDs	223
16.2.4. ICE3-8IOL-K45S-RJ45 LEDs	224
16.3. Using Log Files.....	225
16.3.1. View a Log File	226
16.3.2. Export a Log File	226
16.3.3. Clear a Log File	227

1. Introduction

This document provides installation, configuration, and embedded web interface information for the Pepperl+Fuchs IO-Link master. In addition, it includes detailed information about PROFINET IO and Modbus/TCP.

The web interface provides a platform so that you can easily configure, review diagnostic pages, and access advanced features, such as the ability to:

- Upload the latest IO-Link master images or applications
- Set up user accounts with different user levels and passwords
- Load IODD files and configure IO-Link device parameters
- Implement manual or automatic data storage (upload or download)
- Implement device and/or data validation

1.1. Installation and Configuration Overview

The IO-Link master installation includes the following procedures.

1. Connect the power and Ethernet cable (Page 10).
Note: *ICE3-8IOL-G65L-V1D or ICE3-8IOL1-G65L-V1D: If desired you can use the rotary switch to set the IP address (Page 15).*
2. Download, unzip, and upload the GSD file for the IO-Link master. (Page 26)
3. Insert the IO-Link master in the PROFINET IO system. (Page 27)
4. Configure the IP address for the IO-Link master. (Page 28)
5. Assign the PROFINET Device Name. (Page 39)
6. Set the IO Device Update Time. (Page 42)
7. Configure the IO-Link ports. (Page 81)
 - a. Configure IO-Link port modules.
 - b. Configure port status modules.
 - c. If desired, configure data storage, automatic or manual - upload or download.
 - d. If desired, configure device validation and data validation.
 - e. Use the Diagnostic pages to monitor or troubleshoot your devices.
8. If applicable, use the web interface to configuration pages for the following:
 - Modbus/TCP (Page 90)
 - OPC UA (Page 96)
 - MQTT (Page 99)
9. Refer to *PROFINET IO Reference Information* on Page 154 to complete configuration after attaching the IO-Link devices.



1.2. Locating the Latest Software and Documentation

Go to the Pepperl + Fuchs web site at: <https://www.pepperl-fuchs.com> to locate the latest utilities and documentation for your product. model

For information about images and updating the IO-Link master, see *Updating Images and Applications* on Page 68.

2. Hardware Installation

Use the appropriate hardware installation for your IO-Link master model:

- *ICE3-8IOL-G65L-V1D Hardware Installation on Page 10*
- *ICE3-8IOL1-G65L-V1D Hardware Installation on Page 15*
- *ICE3-8IOL-K45P-RJ45 Hardware Installation on Page 20*
- *ICE3-8IOL-K45S-RJ45 Hardware Installation on Page 23*

Note: Refer to *Connecting Devices on Page 73* for information about connecting IO-Link or digital devices to the ports after you program the network information using the next chapter.

2.1. ICE3-8IOL-G65L-V1D Hardware Installation

Use the following subsections to install the hardware and verify operation.

- *Setting the Rotary Switch*
- *Connecting to the Network on Page 12*
- *Connecting the Power on Page 12*
- *Mounting the ICE3-8IOL-G65L-V1D on Page 14*

Note: Refer to *ICE3-8IOL-G65L-V1D IO-Link Ports on Page 74* for information about connecting IO-Link or digital devices to the ports after you program the network information using the next chapter.

2.1.1. Setting the Rotary Switch

You can use the rotary switches under the configuration window on the IO-Link master to set the lower 3-digits (8 bits) of the static IP address.

Note: *Optionally, you can leave the rotary switch set to the default and use the web interface or PortVision DX to set the network address.*

If the rotary switches are set to a non-default position, the upper 9-digits (24 bits) of the IP address are then taken from the static network address. The switches only take effect during startup, but the current position is always shown on the **SUPPORT** page.

Using the rotary switches to set the IP address may be useful in the following situations:

- A permanent method to assign IP addresses while setting machines for a special application where a PC or laptop is not available.
- A temporary method to assign IP addresses to several IO-Link masters so that they do not have duplicate addresses to make setting the IP addresses using software easier. After using PortVision DX or the web page to change the IP address, reset the rotary switches back to 000.
- An emergency method to return the IO-Link master back to factory defaults, so that software can be used to program the appropriate IP address, and then return the switches back to 000.

Note: *If you set the network address using the rotary switches, the Rotary Switch setting overrides the network settings in the web interface when the IO-Link master is initially powered on or after cycling the power.*

Switch Setting	Node Address
000 (Default setting)	<p>Use the network configuration stored in the flash. The default network configuration values are:</p> <ul style="list-style-type: none"> IP address = 192.168.1.250 Subnet mask = 255.255.255.0 IP gateway = 0.0.0.0 <p>After completing the hardware installation, see <i>Configuring the IO-Link master</i> on Page 27 to set the network address using the web interface or PortVision DX.</p>
001, 255-887	Reserved.
002	Setting the rotary switches to 002 configures the IO-Link master to use DHCP addressing.
003-254	<p>This is the last three digits in the IP address. This uses the first three numbers from the configured static address, which defaults to 192.168.1.xxx.</p> <p>Note: If software is used to change the IP address to another value before setting the rotary switches, the IO-Link master uses that IP address value. For example, if the IO-Link master is set to 10.0.0.250 and the first rotary switch is set to 3, the IP address would still be 10.0.0.250.</p>
888	Reset to factory defaults. If the IO-Link master is set to 888 and the IP address is changed using other methods, the IP address is returned to the default IP address if the IO-Link master is rebooted or power cycled.
889-998	Reserved.
999	Use the default IP address. If the IO-Link master is set to 999 and the IP address is changed using other methods, the IP address is returned to the default IP address if the IO-Link master is rebooted or power cycled.

Use the following steps if you want to change the default rotary switch settings.

1. Gently pop open the window using a small flathead screwdriver.
2. Gently swing open the switch window from the top to the bottom, allowing it to pivot on the hinge on the bottom of the window.
3. Turn each dial to the appropriate position using a small flathead screwdriver.

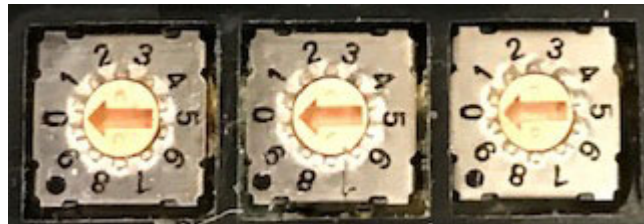

The default setting is 000 as shown above.

The arrow points to the switch location. 0 is located at the 9:00 position. Turn the dial to the appropriate setting.

4. Close the window and make sure that it snaps shut tightly.

Note: Failure to close the configuration window properly may compromise IP67 integrity.

2.1.2. Connecting to the Network

The IO-Link master provides two Fast Ethernet (10/100BASE-TX) M12, 4-pin female D-coded connectors.

Pin	Signal
1	Tx+
2	Rx+
3	Tx-
4	Rx-

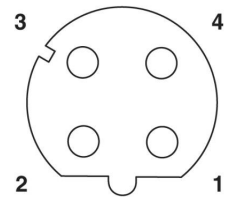

You can use this procedure to connect the IO-Link master to the network.

1. Securely connect one end of a shielded twisted-pair (Cat 5 or higher) M12 Ethernet cable to either Ethernet port.
2. Connect the other end of the cable to the network.
3. Optionally, use the other Ethernet port to daisy-chain to another Ethernet device.
4. If you did not connect both Ethernet ports, make sure that the unused port is covered with a connector cap to keep dust and liquids from getting in the connector.

Note: Ethernet ports must have an approved cable or protective cover attached to the connector to guarantee IP67 integrity.

2.1.3. Connecting the Power

The ICE3-8IOL-G65L-V1D provides M12 (5-poles) L-coded input and output power connectors. Use a 24VDC power supply capable of the total output current required.

Note: Power connectors must have an approved cable or protective cover attached to the port guarantee to IP67 compliance. If you require cables or protective covers, see the Pepperl+Fuchs web site.

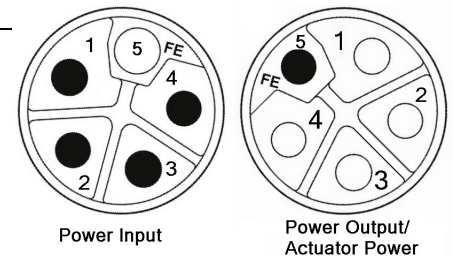

Pin	Power Input (Male)	Power Output or Actuator Power (Female)	Description
1	U _S ⁺	U _S ⁺ or +V	IO-Link master's system electronics and IO-Link devices
2	U _A ⁻	U _A ⁻ or 0V	Actuator supply
3	U _S ⁻	U _S ⁻ or 0V	IO-Link master's system electronics and IO-Link devices
4	U _A ⁺	U _A ⁺ or +V	Actuator supply
5	FE		

Note: The IO-Link master requires a UL listed power supply with an output rating of 24VDC.

Power Supply	Values
Power Supply In - Maximum V_S and V_A	16A (Maximum)
IO-Link Connector Port 1 C/Q (Pin 4) configured as digital output L+/L- Sensor Supply (Pins 1 and 3)	200 mA (Maximum) 1.6A (Maximum)
IO-Link Connector Port 3 C/Q (Pin 4) configured as digital output L+/L- Sensor Supply (Pins 1 and 3)	200 mA (Maximum) 1A (Maximum)
IO-Link Connectors Ports 2 and 4 - 8 C/Q (Pin 4) configured as digital output L+/L- Sensor Supply (Pins 1 and 3)	200 mA (Maximum) 500 mA (Maximum) Note: See ICE3-8IOL-G65L-V1D IO-Link Ports on Page 74 for information about how to divide up the power output between ports.
IO-Link master Power	100mA @ 24VDC (V_S)
Power Supply Out V_S V_A	16A † (Maximum) 16A †† (Maximum)
<p>† V_S output available is determined by subtracting the following from the available input current.</p> <ul style="list-style-type: none"> - IO-Link master module electronics current. - Total L+/L- current for all IO-Link ports. - Total C/Q current for all IO-Link ports. <p>†† V_A output available is the same as the available V_A input current.</p>	

You can use the following procedure to connect the IO-Link master to a power supply.

Note: Power should be disconnected from the power supply before connecting it to the IO-Link master. Otherwise, your screwdriver blade can inadvertently short your power supply terminal connections to the grounded enclosure.

1. Securely attach the power cable between the male power connector (**PWR In**) and the power supply.
2. Either attach a power cable between the female power connector and another device to which you want to provide power or securely attach a connector cap to prevent dust or liquids from getting into the connector. Contact your Customer Sales Representative if you need to order connector caps for the ICE3-8IOL-G65L-V1D.
3. Apply the power and verify that the following LEDs are lit indicating that you are ready to attach your IO-Link or digital I/O devices.
 - a. The **US** LED lights.
 - b. The **ETH1/ETH2** LED lights on the connected port.
 - c. The **MOD** and **NET** LEDs are lit.
 - d. The IO-Link LEDs  flash (if no IO-Link device attached) or are lit if an IO-Link device is attached.

Note: It takes approximately 25 seconds after power up for the IO-Link master to be ready for operation.

 - e. If a PLC is connected, the **NET** LED is lit and green.

If the LEDs indicate that you are ready to go to the next installation step:

- Program the IP address using PortVision DX or the web interface. Refer to *Configuring the IO-Link master* on Page 27 for configuring the network information.
- If using the rotary switches to set the IP address, then you are ready to attach devices using *Connecting Devices* on Page 73.

If the LEDs do not meet the above conditions, you can refer to *ICE3-8IOL1-G65L-V1D LEDs* on Page 220 in the *Troubleshooting* chapter for more information.

2.1.4. Mounting the ICE3-8IOL-G65L-V1D

Use the following procedure to mount the IO-Link master. You can mount the IO-Link master on a mounting panel or a machine.

1. Verify that the mounting surface is level (flat) to prevent mechanical stress to the IO-Link master.
2. Attach the IO-Link master to the surface with two 6mm screws and washers, torque down to 8Nm.

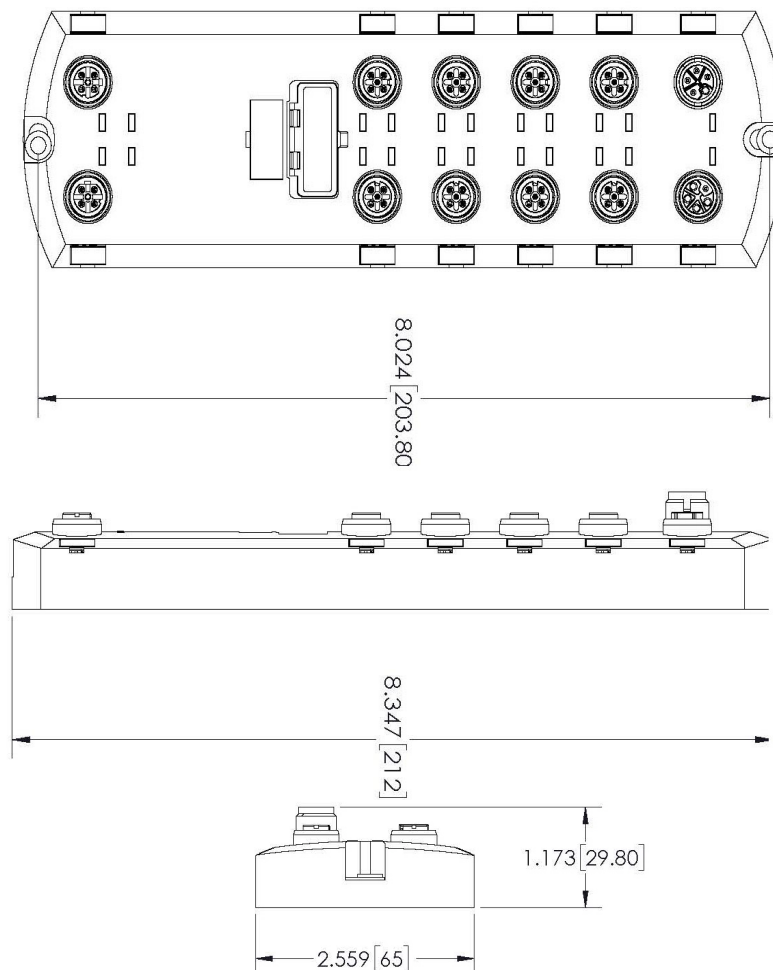

2.2. ICE3-8IOL1-G65L-V1D Hardware Installation

Use the following subsections to install the hardware and verify operation.

- *Setting the Rotary Switch*
- *Connecting to the Network on Page 17*
- *Connecting the Power on Page 17*
- *Mounting the ICE3-8IOL1-G65L-V1D on Page 19*

Note: Refer to *ICE3-8IOL1-G65L-V1D IO-Link Ports on Page 76* for information about connecting IO-Link or digital devices to the ports after you program the network information using the next chapter.

2.2.1. Setting the Rotary Switch

You can use the rotary switches under the configuration window on the IO-Link master to set the lower 3-digits (8 bits) of the static IP address.

Note: *Optionally, you can leave the rotary switch set to the default and use the web interface or PortVision DX to set the network address.*

If the rotary switches are set to a non-default position, the upper 9-digits (24 bits) of the IP address are then taken from the static network address. The switches only take effect during startup, but the current position is always shown on the **SUPPORT** page.

Using the rotary switches to set the IP address may be useful in the following situations:

- A permanent method to assign IP addresses while setting machines for a special application where a PC or laptop is not available.
- A temporary method to assign IP addresses to several IO-Link masters so that they do not have duplicate addresses to make setting the IP addresses using software easier. After using PortVision DX or the web page to change the IP address, reset the rotary switches back to 000.
- An emergency method to return the IO-Link master back to factory defaults, so that software can be used to program the appropriate IP address, and then return the switches back to 000.

Note: *If you set the network address using the rotary switches, the Rotary Switch setting overrides the network settings in the web interface when the IO-Link master is initially powered on or after cycling the power.*

Switch Setting	Node Address
000 (Default setting)	Use the network configuration stored in the flash. The default network configuration values are: <ul style="list-style-type: none"> • IP address = 192.168.1.250 • Subnet mask = 255.255.255.0 • IP gateway = 0.0.0.0 After completing the hardware installation, see <i>Configuring the IO-Link master on Page 27</i> to set the network address using the web interface or PortVision DX.
001, 255-887	Reserved.
002	Setting the rotary switches to 002 configures the IO-Link master to use DHCP addressing.

Switch Setting	Node Address (Continued)
003-254	This is the last three digits in the IP address. This uses the first three numbers from the configured static address, which defaults to 192.168.1.xxx. Note: <i>If software is used to change the IP address to another value before setting the rotary switches, the IO-Link master uses that IP address value. For example, if the IO-Link master is set to 10.0.0.250 and the first rotary switch is set to 3, the IP address would still be 10.0.0.250.</i>
888	Reset to factory defaults. If the IO-Link master is set to 888 and the IP address is changed using other methods, the IP address is returned to the default IP address if the IO-Link master is rebooted or power cycled.
889-998	Reserved.
999	Use the default IP address. If the IO-Link master is set to 999 and the IP address is changed using other methods, the IP address is returned to the default IP address if the IO-Link master is rebooted or power cycled.

Use the following steps if you want to change the default rotary switch settings.

1. Gently pop open the window using a small flathead screwdriver.
2. Gently swing open the switch window from the top to the bottom, allowing it to pivot on the hinge on the bottom of the window.
3. Turn each dial to the appropriate position using a small flathead screwdriver.

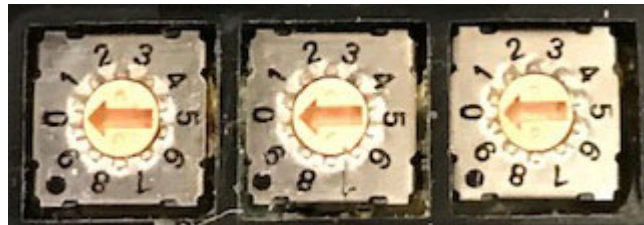

The default setting is 000 as shown above.

The arrow points to the switch location. 0 is located at the 9:00 position. Turn the dial to the appropriate setting.

4. Close the window and make sure that it snaps shut tightly.

Note: *Failure to close the configuration window properly may compromise IP67 integrity.*

2.2.2. Connecting to the Network

The IO-Link master provides two Fast Ethernet (10/100BASE-TX) M12, 4-pin female D-coded connectors.

Pin	Signal
1	Tx+
2	Rx+
3	Tx-
4	Rx-

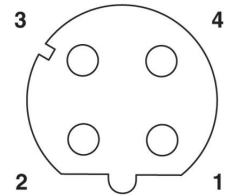

You can use this procedure to connect the IO-Link master to the network.

1. Securely connect one end of a shielded twisted-pair (Cat 5 or higher) M12 Ethernet cable to either Ethernet port.
2. Connect the other end of the cable to the network.
3. Optionally, use the other Ethernet port to daisy-chain to another Ethernet device.
4. If you did not connect both Ethernet ports, make sure that the unused port is covered with a connector cap to keep dust and liquids from getting in the connector.

Note: Ethernet ports must have an approved cable or protective cover attached to the connector to guarantee IP67 integrity.

2.2.3. Connecting the Power

The ICE3-8IOL1-G65L-V1D provides M12 (5-poles) L-coded input and output power connectors. Use a 24VDC power supply capable of the total output current required.

Note: Power connectors must have an approved cable or protective cover attached to the port guarantee to IP67 compliance. If you require cables or protective covers, see the Pepperl+Fuchs web site.

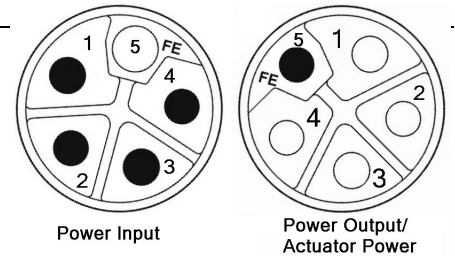

Pin	Power Input (Male)	Power Output or Actuator Power (Female)	Description
1	U _S +	U _S + or +V	IO-Link master's system electronics and IO-Link devices
2	U _A -	U _A - or 0V	Actuator supply
3	U _S -	U _S - or 0V	IO-Link master's system electronics and IO-Link devices
4	U _A +	U _A + or +V	Actuator supply
5	FE		

Note: The IO-Link master requires a UL listed power supply with an output rating of 24VDC.

Power Supply	Values
Power Supply In - Maximum V_S and V_A	16A (Maximum)
IO-Link Connector Port 1B (Class B) C/Q (Pin 4) configured as digital output L+/L- Sensor Supply (Pins 1 and 3)	Max 500mA via L+ (Pin 1) Max 3.5A via 2L+ (Pin 2) Max 200mA via C/Q (Pin 4)
IO-Link Connector Ports 2B through 4B (Class B) C/Q (Pin 4) configured as digital output L+/L- Sensor Supply (Pins 1 and 3)	Max 500mA via L+ (Pin 1) Max 2.3A via 2L+ (Pin 2) Max 200mA via C/Q (Pin 4)
IO-Link Connectors Ports 5A through 8A (Class A) C/Q (Pin 4) configured as digital output L+/L- Sensor Supply (Pins 1 and 3)	Max 500mA via L+ (Pin 1) Max 200mA via C/Q (Pin 4) Max 200mA via DO (Pin 2) Note: See ICE3-8IOL1-G65L-V1D IO-Link Ports on Page 76 for information about how to divide up the power output between ports.
IO-Link master Power	120mA @ 24VDC (V_S)
Power Supply Out V_S V_A	16A † (Maximum) 16A †† (Maximum) Note: DO current for the Class A DO pins, if used. So V_A would be the same as for V_S with this one exception.
<p>† V_S output available is determined by subtracting the following from the available input current.</p> <ul style="list-style-type: none"> - IO-Link master module electronics current. - Total L+/L- current for all IO-Link ports. - Total C/Q current for all IO-Link ports. <p>†† V_A output available is the same as the available V_A input current.</p>	

You can use the following procedure to connect the IO-Link master to a power supply.

Note: Power should be disconnected from the power supply before connecting it to the IO-Link master. Otherwise, your screwdriver blade can inadvertently short your power supply terminal connections to the grounded enclosure.

1. Securely attach the power cable between the male power connector (**PWR In**) and the power supply.
2. Either attach a power cable between the female power connector and another device to which you want to provide power or securely attach a connector cap to prevent dust or liquids from getting into the connector. Contact your Customer Sales Representative if you need to order connector caps for the ICE3-8IOL1-G65L-V1D.
3. Apply the power and verify that the following LEDs are lit indicating that you are ready to attach your IO-Link or digital I/O devices.
 - a. The **US** LED lights.

Note: If the power supply applies power to Pin 2, the UA LED also lights green.

 - b. The **ETH1/ETH2** LED lights on the connected port.
 - c. The **MOD** and **NET** LEDs are lit.

- d. The IO-Link LEDs  flash (if no IO-Link device attached) or are lit if an IO-Link device is attached.

Note: It takes approximately 25 seconds after power up for the IO-Link master to be ready for operation.

- e. If a PLC is connected, the **NET** LED is lit and green.

If the LEDs indicate that you are ready to go to the next installation step:

- Program the IP address using PortVision DX or the web interface. Refer to *Configuring the IO-Link master* on Page 27 for configuring the network information.
- If using the rotary switches to set the IP address, then you are ready to attach devices using *Connecting Devices* on Page 73.

If the LEDs do not meet the above conditions, you can refer to *ICE3-8IOL1-G65L-V1D LEDs* on Page 220 in the *Troubleshooting* chapter for more information.

2.2.4. Mounting the ICE3-8IOL1-G65L-V1D

Use the following procedure to mount the IO-Link master. You can mount the IO-Link master on a mounting panel or a machine.

1. Verify that the mounting surface is level (flat) to prevent mechanical stress to the IO-Link master.
2. Attach the IO-Link master to the surface with two 6mm screws and washers, torque down to 8Nm.

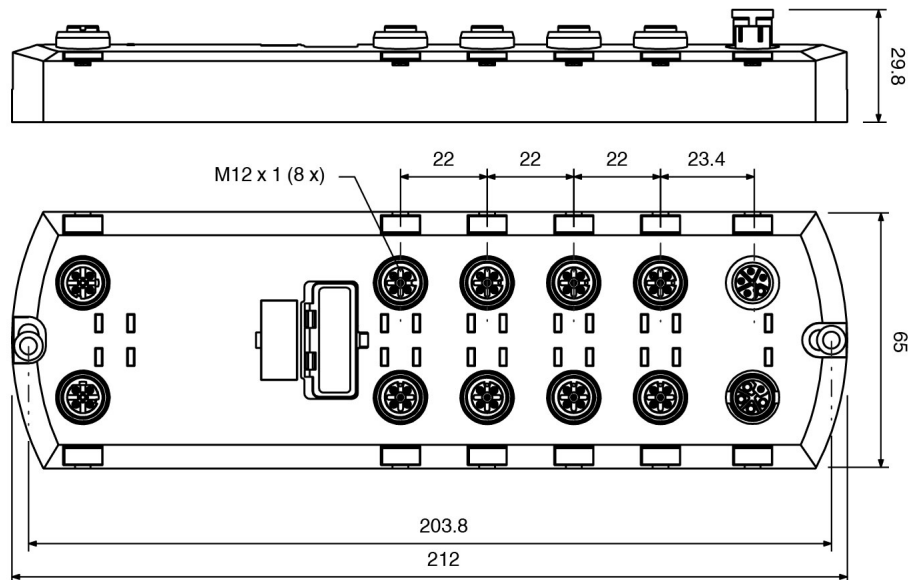

2.3. ICE3-8IOL-K45P-RJ45 Hardware Installation

Use the following information to install the hardware for the ICE3-8IOL-K45P-RJ45.

- *Connecting to the Network* on Page 20
- *Connecting the Power* on Page 21
- *Mounting* on Page 22

Note: The ICE3-8IOL-K45P-RJ45 must be installed in a suitable fire, electrical, mechanical enclosure.

Depending on your preference you can connect the ICE3-8IOL-K45P-RJ45 using several methods:

- First mount the ICE3-8IOL-K45P-RJ45 and connect the power with it attached to the DIN rail.
- Remove the connector with a small flat screwdriver, connect the power, and insert the connector into the receptacle.

Note: Refer to ICE3-8IOL-K45P-RJ45 IO-Link Ports on Page 78 for information about connecting IO-Link or digital devices to the ports after you program the network information using the next chapter.

2.3.1. Connecting to the Network

The IO-Link master provides two Fast Ethernet (10/100BASE-TX) standard RJ45 connectors.

Pin	Signal
1	Tx+
2	Tx-
3	Rx+
6	Rx-

Port 2
(PROFINET)

Port 1
(PROFINET)



You can use this procedure to connect the IO-Link master to the network or IO controller.

1. Securely connect one end of the RJ45 Ethernet cable to either Ethernet port.
2. Connect the other end to the network or an IO controller.
3. Optionally, use the other Ethernet port to daisy-chain to another Ethernet device.

Note: If you do not connect the IO-Link master to an IO controller, an IO controller needs to be connected to the network for PROFINET IO configuration.

2.3.2. Connecting the Power

The ICE3-8IOL-K45P-RJ45 provides redundant power input with a single pluggable connector on the top of the IO-Link master. The power plug is keyed for your safety so that it cannot be inserted into an IO-Link port using the headers and plugs keyed as supplied.

Signal	Pins	Description
V-	1 and 2	24VDC Power Supply Return
V+	3	Primary +24VDC Supply
V+	4	Secondary +24VDC Supply

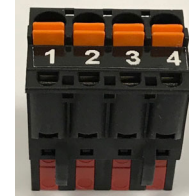

Power Supply	Values
Power Supply In (V+)	3.7A (Maximum) †
IO-Link Connectors Ports 1 - 8 C/Q L+	200 mA (Maximum) 200 mA (Maximum)
IO-Link master Power	155mA @ 24VDC (V _S)
† The sum of the following must not exceed V+ maximum input current: <ul style="list-style-type: none"> - IO-Link Mode module power - Actual C/Q current for each IO-Link port - Actual U_S current for each IO-Link port 	

You can use this procedure to connect the IO-Link master to a UL Listed power supply and UL Listed power cord.

Note: Power should be disconnected from the power supply before connecting it to the IO-Link master. Otherwise, your screwdriver blade can inadvertently short your connections to the grounded enclosure.

1. Optionally, use a small screw driver to remove the power connector from the receptacle.
2. Depress the orange tab until it is flush with the connector to insert positive and negative solid or ferrule wires (12-24AWG) into the V+ and V- contacts.
3. If necessary, re-insert the connector into the power receptacle.
4. Apply the power and verify that the following LEDs are lit indicating that you are ready to program the IP address and then attach your IO-Link devices.
 - a. The **ETH1/ETH2** LED lights on the connected port.
 - b. The **MOD** and **NET** LEDs are lit.
 - c. The IO-Link LEDs  flash (if no IO-Link device attached) or are lit if an IO-Link device is attached.
 - d. If a PLC is connected, the **NET** LED is lit and green.

If the LEDs indicate that you are ready to go to the next installation step. Refer to *Configuring the IO-Link master* on Page 27 to configure the network information.

If the LEDs do not meet the above conditions, you can refer to *ICE3-8IOL-K45P-RJ45 LEDs* on Page 223 in the *Troubleshooting* chapter for more information.

2022-12

2.3.3. Mounting

You may want to mount the IO-Link master after programming the IP address and connecting the IO-Link and digital input/output devices.

1. Slide the metal latch down, hook the top of the ICE3-8IOL-K45P-RJ45 to the DIN rail and release the latch.
2. Verify that it is tightly mounted.

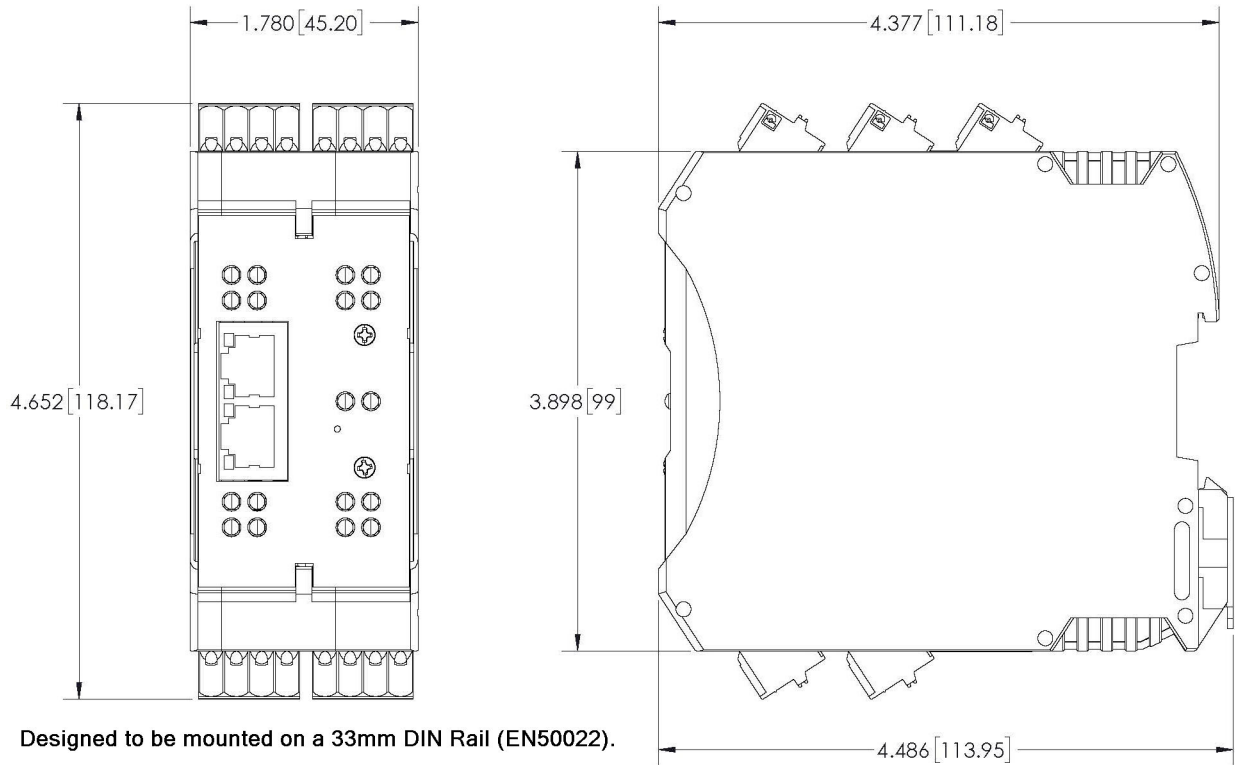

Note: You may want to connect the IO-Link devices before attaching the ICE3-8IOL-K45P-RJ45 to the DIN rail. Use Connecting Devices on Page 73 if you require IO-Link cabling information.

2.4. ICE3-8IOL-K45S-RJ45 Hardware Installation

Use the following information to install the hardware for the ICE3-8IOL-K45S-RJ45.

- *Connecting to the Network* on Page 23
- *Connecting the Power* on Page 24
- *Mounting* on Page 25

Note: The ICE3-8IOL-K45S-RJ45 must be installed in a suitable fire, electrical, mechanical enclosure.

Depending on your preference you can connect the ICE3-8IOL-K45S-RJ45 using several methods:

- First mount the ICE3-8IOL-K45S-RJ45 and connect the power with it attached to the DIN rail.
- Remove the connector with a small flat screwdriver, connect the power, and insert the connector into the receptacle.

Note: Refer to ICE3-8IOL-K45S-RJ45 IO-Link Ports on Page 79 for information about connecting IO-Link or digital devices to the ports after you program the network information using the next chapter.

2.4.1. Connecting to the Network

The IO-Link master provides two Fast Ethernet (10/100BASE-TX) standard RJ45 connectors.

Pin	Signal
1	Tx+
2	Tx-
3	Rx+
6	Rx-

Port 2
(PROFINET)

Port 1
(PROFINET)



You can use this procedure to connect the IO-Link master to the network or IO controller.

1. Securely connect one end of the RJ45 Ethernet cable to either Ethernet port.
2. Connect the other end to the network or an IO controller.
3. Optionally, use the other Ethernet port to daisy-chain to another Ethernet device.

Note: If you do not connect the IO-Link master to an IO controller, an IO controller needs to be connected to the network for PROFINET IO configuration.

2.4.2. Connecting the Power

The ICE3-8IOL-K45S-RJ45 provides power input with a pluggable screw terminal on the top of the unit. The power plug is keyed for your safety so that it cannot be inserted into an IO-Link port using the headers and plugs keyed as supplied



Signal	Pins	Description
V-	1 and 2	24VDC Power Supply Return
V+	3	Primary +24VDC Supply
V+	4	Secondary +24VDC Supply

Note: The ICE3-8IOL-K45S-RJ45 must be installed in a suitable fire, electrical, mechanical enclosure.

Power Supply	Values
Power Supply In V+	3.7A (Maximum) †
IO-Link Connectors Ports 1 - 8 C/Q L+	200 mA (Maximum) 200 mA (Maximum)
IO-Link master Power	155mA @ 24VDC (V _S)
† The sum of the following must not exceed V+ maximum input current: <ul style="list-style-type: none"> - IO-Link Mode module power - Actual C/Q current for each IO-Link port - Actual U_S current for each IO-Link port 	

You can use this procedure to connect the IO-Link master to a UL Listed power supply and UL Listed power cord.

Note: Power should be disconnected from the power supply before connecting it to the IO-Link master. Otherwise, your screwdriver blade can inadvertently short your terminal connections to the grounded enclosure.

1. Insert positive and negative wires (12-24AWG) into the V+ and V- contacts.
2. Tighten the wire-clamp screws to prevent the wires from coming loose.
3. Apply the power and verify that the following LEDs are lit indicating that you are ready to program the IP address and then attach your IO-Link devices.
 - a. The **E1/E2** LED lights on the connected port.
 - b. The **MOD** and **NET** LEDs are lit.
 - c. The IO-Link LEDs  flash (if no IO-Link device attached) or are lit if an IO-Link device is attached.
 - d. If a PLC is connected, the **NET** LED is lit and green.

If the LEDs indicate that you are ready to go to the next installation step. Refer to *Configuring the IO-Link master* on Page 27 to configure the network information.

If the LEDs do not meet the above conditions, you can refer to *ICE3-8IOL-K45S-RJ45 LEDs* on Page 224 in the *Troubleshooting* chapter for more information.

2.4.3. Mounting

You may want to mount the IO-Link master after programming the IP address and connecting the IO-Link and digital input/output devices.

1. Slide the metal latch down, hook the top of the ICE3-8IOL-K45S-RJ45 to the DIN rail and release the latch.
2. Verify that it is tightly mounted.

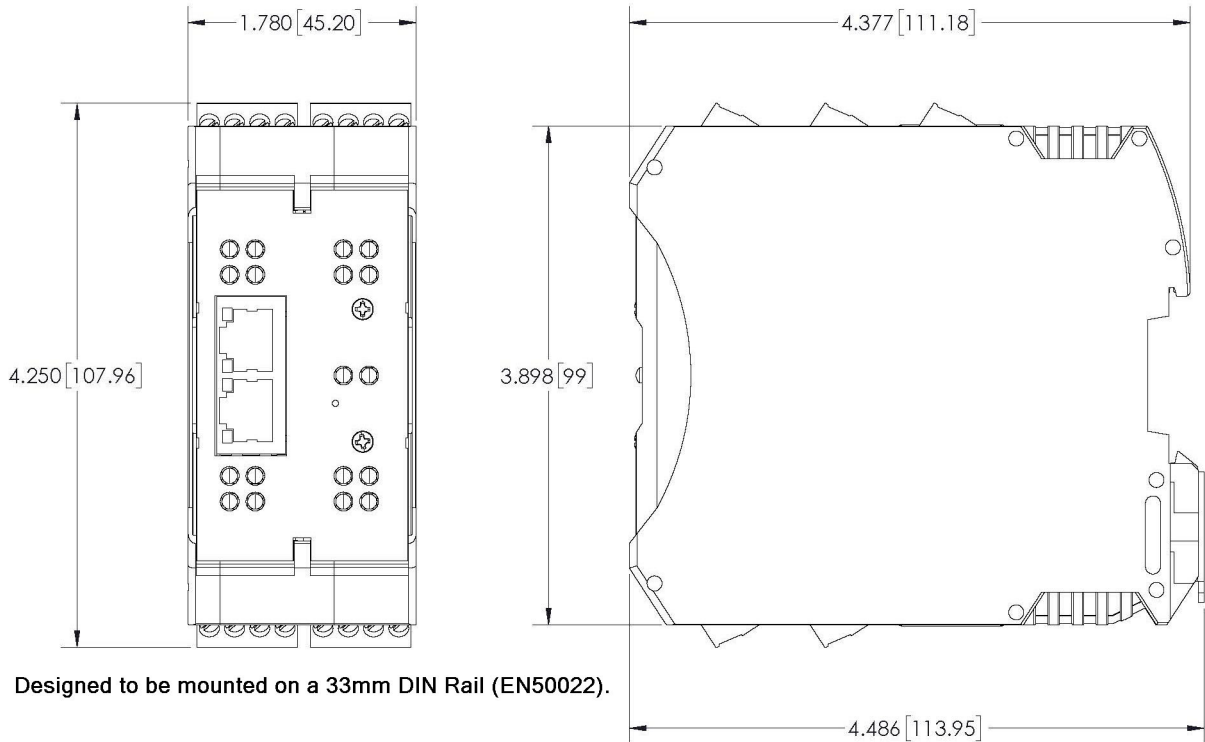

You may want to connect the IO-Link devices before attaching the ICE3-8IOL-K45S-RJ45 to the DIN rail. Use Connecting Devices on Page 73 if you require IO-Link cabling information.

3. Configuring the IO-Link master with STEP 7 or TIA Portal

3.1. Overview

PROFINET IO configuration procedures vary between software versions but the following configuration steps are required in all cases. Refer to your STEP 7 documentation, if you require step-by-step procedures.

1. Download, unzip, and upload the GSD file for the IO-Link master.
2. Insert the IO-Link master in the PROFINET IO system.
3. Configure the IP address for the IO-Link master.
4. Assign the PROFINET Device Name.
5. Set the IO Device Update Time.
6. Configure the IO-Link ports.
 - a. Configure IO-Link port modules.
 - b. Configure port status modules.
 - c. If desired, configure data storage, automatic or manual - upload or download.
 - d. If desired, configure device validation and data validation.
7. Use *PROFINET IO Reference Information* on Page 154 to complete configuration after attaching the IO-Link devices.

The following subsections provides PROFINET IO configuration procedures using STEP 7 V5.5 and TIA Portal V13:

- *Installing the GSD File*
- *Configuring the IO-Link master on Page 27*
- *IP Address Assignment on Page 28*
- *Device Name Assignment on Page 39*
- *Setting the IO Device Update Time on Page 42*
- *Configuring IO-Link Ports on Page 44*

3.2. Installing the GSD File

Use the following procedure to install the GSD file for PROFINET IO using STEP 7 V5.5.

1. Unzip **GSDML-V2.xx-Pepperl+Fuchs-ICE38IOL-yyyymmdd.zip** to a working directory.
2. Use the appropriate steps:

STEP 7 V5.5:

- a. Open **SIMATIC STEP 7 | HW Config**.
- b. Use **Menu Options | Install GSD Files** to install the GSD file.

TIA Portal V13:

- a. Open the TIA Portal and switch to the **Project** view.
- b. Use **Menu Options | manage general station description files (GSD)** to install the GSD file.

Note: If an older version of the GSD file was installed before, you may need to remove the IO-Link master

object from an existing project, and reinsert it after the new GSDML file is installed.

3.3. Configuring the IO-Link master

Use the appropriate procedure for your environment.

- STEP 7 V5.5
- TIA Portal V13 on Page 28

3.3.1. STEP 7 V5.5

Select the IO-Link master from the *Hardware Catalog* window and insert it into a PROFINET-IO- System in the **HW Config (PROFINET IO | Additional Field Device | Gateway | Pepperl+Fuchs | ICE3-8IOL)** as shown in Figure 1.

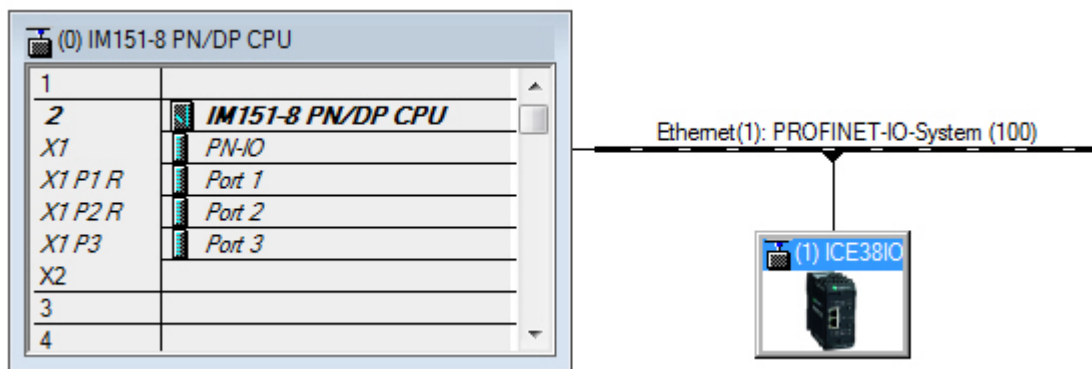
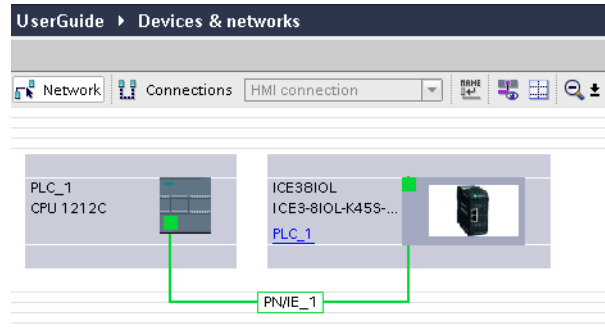

Figure 1: Inserting an ICE3-8IOL-K45S-RJ45 into a PROFINET IO System.

3.3.2. TIA Portal V13

Select the IO-Link master from the **Hardware** catalog window (Other field devices | PROFINET IO | Gateway | Pepperl+Fuchs | ICE3-8IOL) and drag it into the **Device configuration | Network** view. Then connect the IO-Link master to the IO controller, as shown in the Figure below.



3.4. IP Address Assignment

Pepperl+Fuchs gateways support three methods for IP address assignment according to *GSDML Specification*.

- **DCP** - The IO-Link master supports IP address assignment via Discovery and basic Configuration Protocol (DCP). See *Assigning an IP Address via IO Controller (DCP)* on Page 28 for procedures.
- **DHCP** - The IO-Link master supports the Dynamic Host Configuration Protocol for IP address assignment. See *Assigning an IP Address via DHCP* on Page 31 for procedures.
- **LOCAL** - The IO-Link master supports a device specific method for IP address assignment. See *Assigning an IP Address Statically (LOCAL)* on Page 33 for procedures.

3.4.1. Assigning an IP Address via IO Controller (DCP)

An IO controller can assign an IP address to the Pepperl+Fuchs gateway via DCP. The IO controller and the Pepperl+Fuchs gateway have to be on the same subnet. The IO-Link master default IP address is: 192.168.1.250 and the subnet mask is 255.255.255.0.

Use the appropriate procedure for your environment.

- *STEP 7 V5.5*
- *TIA Portal V13*

3.4.1.1. STEP 7 V5.5

Use the following procedure to assign an IP address via DCP.

1. Double-click the **X1 PNIO-IO** interface of the IO control to open the *Properties* window.
2. On the **General** tab, click the **Properties** button, which opens the *Ethernet interface Properties* window.
3. Uncheck the **Use different method to obtain IP address** option.
4. Manually enter the IP address and subnet mask for the IO controller.

In this example the IO controller was assigned an IP address of 10.0.0.31 and a subnet mask of 255.0.0.0.

5. Double-click the IO-Link master, check **Assign IP address via IO controller** as shown in Figure 3.
6. On the **General** tab, click the **Ethernet** button, which opens the *Ethernet interface properties* window, where you can specify what IP address the IO controller should assign to the IO-Link master.

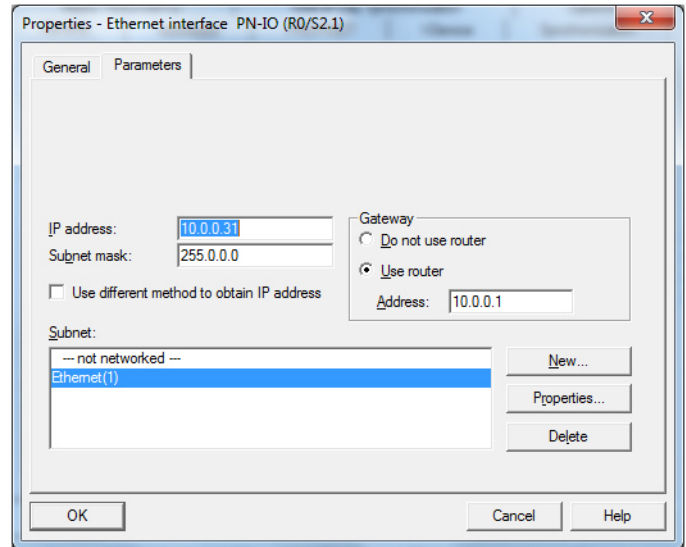

Figure 2: IO Controller Ethernet Interface Properties

Steps 2 through 4 are necessary in STEP 7 V5.5 so that both the IO controller and the IO-Link master are on the same subnet. Otherwise, the **Assign IP address via IO controller** function may not work correctly.

In this example, IP address 10.0.0.100 is assigned to the IO-Link master via the IO controller.

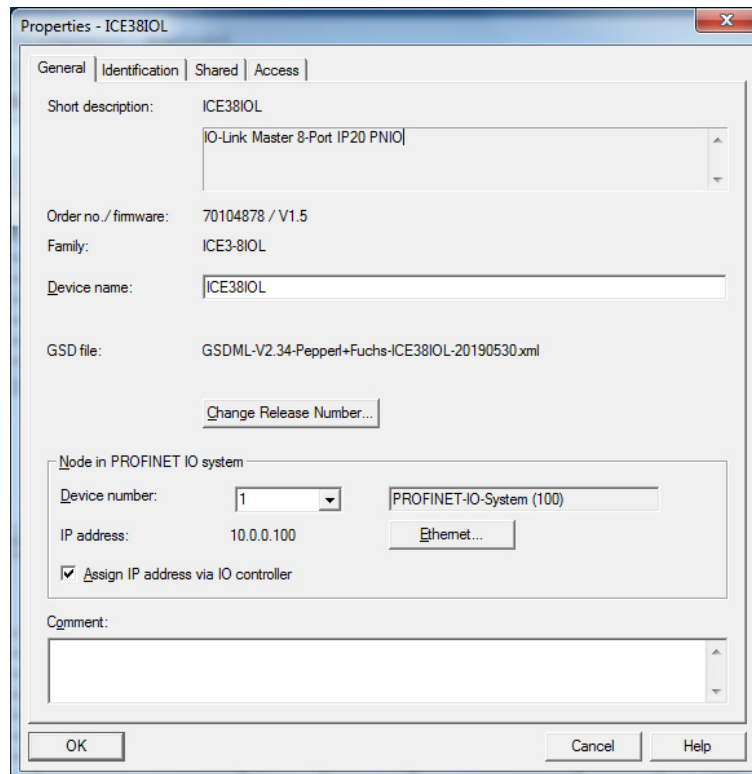
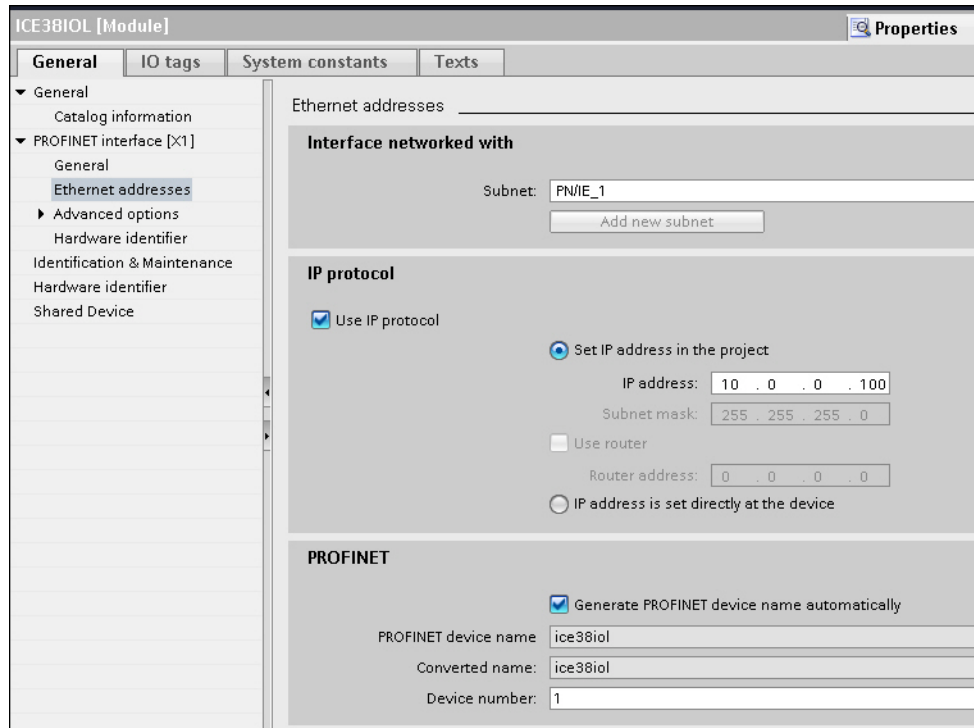

Figure 3: IO-Link master Properties

3.4.1.2. TIA Portal V13

Use the following procedure to assign an IP address via DCP.

1. Double-click the IO-Link master in the **Device configuration | Network** view.
2. On the **Properties | General tag**, select **Ethernet addresses**.
 - a. Make sure that the **User IP protocol** option is checked and the **Set IP address in the project** is selected.
 - b. Enter the desired IP address for the IO-Link master. In this example the IP address 10.0.0.100 is assigned to the IO-Link master via the IO controller.



3.4.2. Assigning an IP Address via DHCP

The Pepperl+Fuchs gateway supports DHCP for IP address assignment. DHCP is disabled by default. Use the following steps to enable DHCP.

Note: The IO-Link master default IP address is: 192.168.1.250 and the subnet mask is 255.255.255.0. You may need to change your laptop or PC IP address range to access the IO-Link master web interface or you can use IO-Link master to change the IP address without changing your settings.

1. Open a web browser and enter the IO-Link master IP address.
2. Click **Configuration | Network**.
3. Click **EDIT** button.

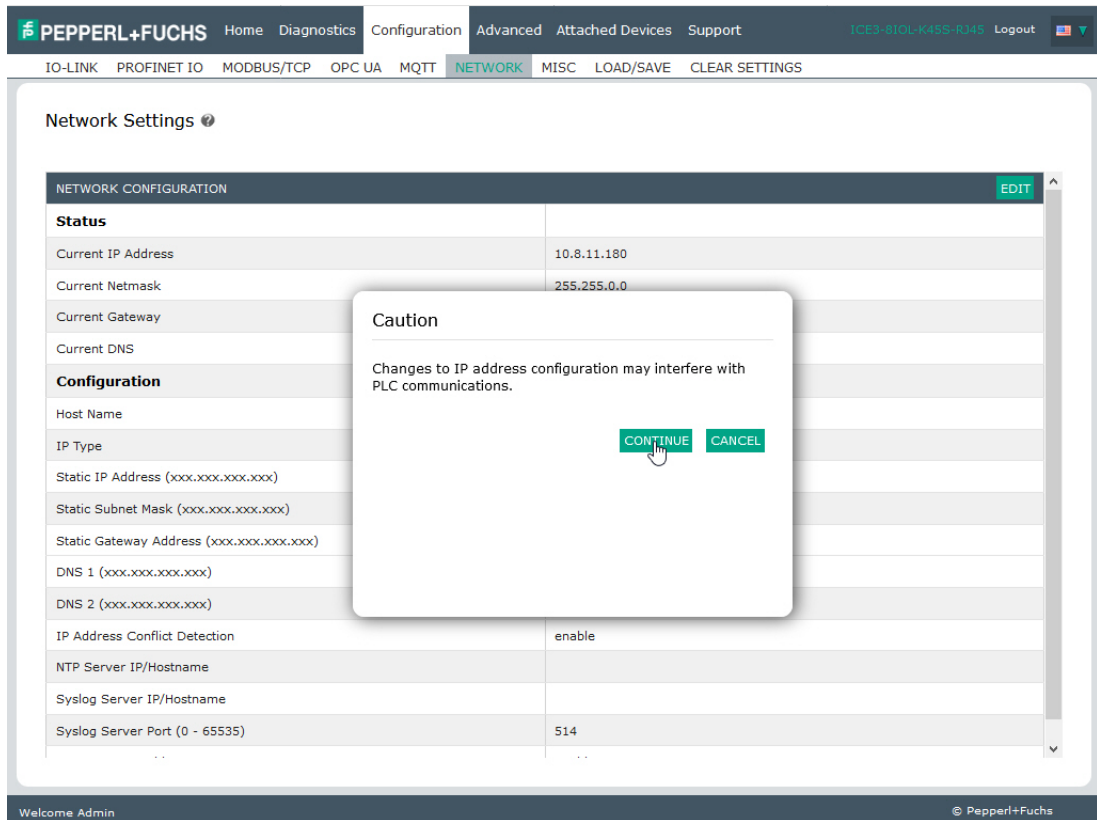

Figure 4: Web Network Configuration Page

4. Change **IP Type** from **static** to **dhcp**.

The screenshot shows the 'Network Settings' page in the Pepperl+Fuchs web interface. The page has a dark header with navigation links: Home, Diagnostics, Configuration, Advanced, Attached Devices, Support. The user is logged in as 'ICE3-BIOL-K455-RJ45'. Below the header is a secondary navigation bar with links: IO-LINK, PROFINET IO, MODBUS/TCP, OPC UA, MQTT, NETWORK (selected), MISC, LOAD/SAVE, CLEAR SETTINGS.

The main content area is titled 'Network Settings' and contains a 'NETWORK CONFIGURATION' table. The table has two columns: 'Parameter' and 'Value'. The 'IP Type' parameter is highlighted in blue and has a dropdown menu set to 'dhcp'. Other parameters include Current IP Address (10.8.11.180), Current Netmask (255.255.0.0), Current Gateway (10.8.0.254), Current DNS, Host Name, DNSmode (automatic), IP Address Conflict Detection (enable), NTP Server IP/Hostname, Syslog Server IP/Hostname, Syslog Server Port (514), and SSH Server Enable (enable). There are 'CANCEL' and 'SAVE' buttons in the top right corner of the configuration table.

NETWORK CONFIGURATION		CANCEL	SAVE
Status			
Current IP Address	10.8.11.180		
Current Netmask	255.255.0.0		
Current Gateway	10.8.0.254		
Current DNS			
Configuration			
Host Name	<input type="text"/>		
IP Type	dhcp		
DNSmode	automatic		
IP Address Conflict Detection	enable		
NTP Server IP/Hostname	<input type="text"/>		
Syslog Server IP/Hostname	<input type="text"/>		
Syslog Server Port (0 - 65535)	514		
SSH Server Enable	enable		

Welcome Admin © Pepperl+Fuchs

5. Click the **SAVE** button.

Once DHCP is enabled, the IO-Link master attempts to obtain an IP address from a DHCP server. If a new IP address is assigned by a DHCP server, then the IO-Link master switches to the new IP address immediately. This may interfere with communications between the device and the IO controller.

The **Obtain IP address from a DHCP server** option in the *Edit Ethernet Node* window in STEP 7 (Figure 5, Page 34) is not supported. DHCP can only be enabled or disabled via the web interface.

Note: An IO controller can overwrite DHCP IP assignment by assigning IP address via DCP.

The next configuration step is to assign the device name, go to *Device Name Assignment* on Page 39.

3.4.3. Assigning an IP Address Statically (LOCAL)

IP addresses can also be assigned statically using one of the following methods:

- The **LOCAL** method as defined in the GSDML Specification
- Embedded web interface

Use the appropriate procedure for your environment:

- *STEP 7 V5.5*
- *TIA Portal V13* on Page 35

3.4.3.1. STEP 7 V5.5

Use the following procedure if you want to use the LOCAL method using STEP 7.

1. In the *STEP 7 HW Config* window, double-click the IO-Link master object to open up the *Properties* window.

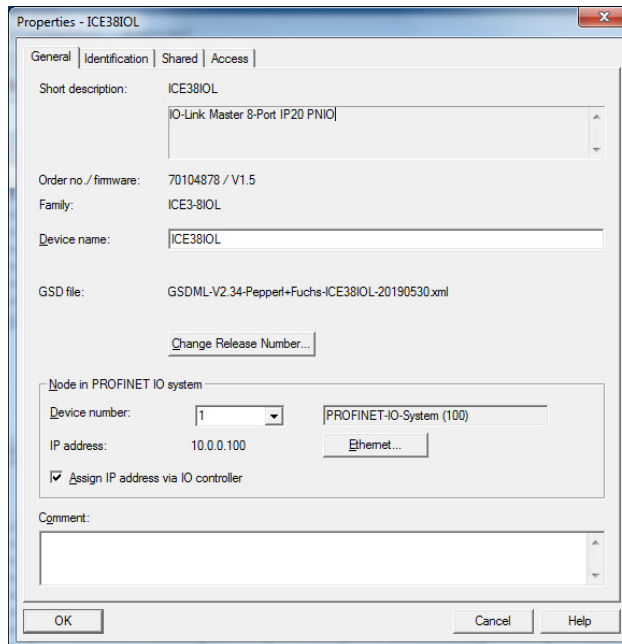

2. Uncheck the **Assign IP address via IO controller** option and click **OK**.
3. Download and run the project.
 The IO controller will not attempt to assign IP address to the IO-Link master. You must assign a static IP address to the IO-Link master manually.
4. Select the IO-Link master in **HW Config**, open the *Edit Ethernet Node* window (Figure 5, Page 34) by using menu **PLC | Ethernet | Edit Ethernet Node** option.
5. Once opened, click the **Browse** button, which opens the *Browse Network* window.
 The IO-Link master should be displayed as an Pepperl+Fuchs IO-Link master with a default IP address of 192.168.1.250.
6. Select the IO-Link master and click the **OK** button to return to the *Edit Ethernet Node* window.
7. Enter the desired IP configurations.

In Figure 5, the IO-Link master was configured to use a static IP address 10.0.0.100, subnet mask 255.0.0.0 and no router.

- Click the **Assign IP Configuration** button, the IP configuration is assigned to the IO-Link master.

The screenshot shows the 'Edit Ethernet Node' dialog box. It is divided into several sections:

- Ethernet node:** Contains a 'MAC address' field with the value '00-0D-81-08-CC-9F' and a 'Browse...' button. The text 'Nodes accessible online' is visible above the field.
- Set IP configuration:** Contains two radio buttons: 'Use IP parameters' (which is selected) and 'Obtain IP address from a DHCP server'.
 - Under 'Use IP parameters':
 - IP address: 10.0.0.100
 - Subnet mask: 255.0.0.0
 - Gateway: 'Do not use router' (selected) and 'Use router'.
 - Under 'Obtain IP address from a DHCP server':
 - Identified by: 'Client ID' (selected), 'MAC address', and 'Device name'.
 - Client ID: [Empty field]
- Assign device name:** Contains a 'Device name' field with the value 'ICE39IOL' and an 'Assign Name' button.
- Reset to factory settings:** Contains a 'Reset' button.
- At the bottom: 'Close' and 'Help' buttons.

Figure 5: Configure IP Address and Device Name

The next configuration step is to assign the device name, go to *Device Name Assignment* on Page 39.

3.4.3.2. TIA Portal V13

Use the following procedure if you want to set the LOCAL method using TIA Portal.

1. Double-click the IO-Link master in the **Device configuration | Network** view.
2. On the **Properties | General tag**, select **Ethernet addresses**.
3. Make sure that the **User IP protocol** option is checked and the **IP address is set directly at the device** is selected.
4. Download and run the project. The IO controller will not attempt to assign IP address to the IO-Link master. You must assign a static IP address to the IO-Link master manually.

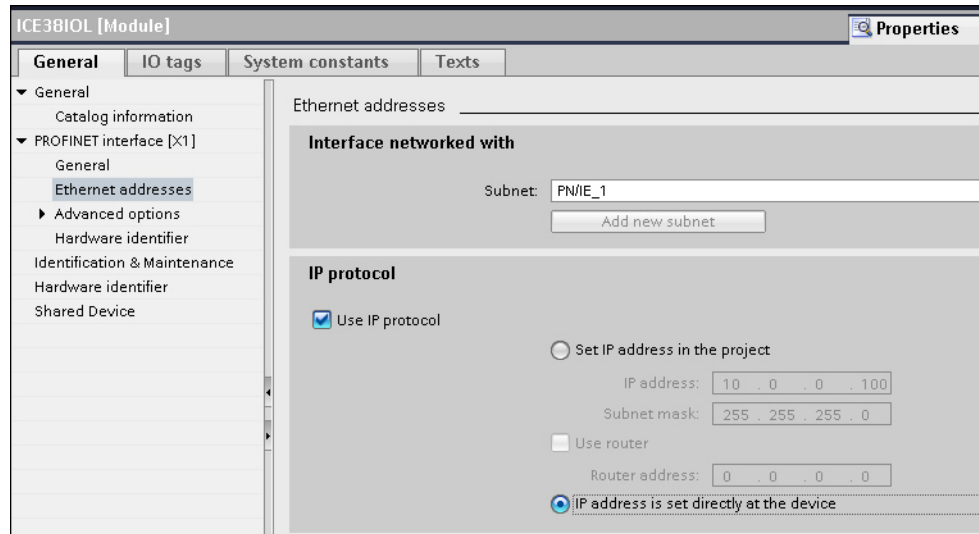

5. In the TIA Portal Project view, navigate to **Project tree | Online access**, double-click the **Ethernet adapter that is used as PROFINET IO network in your system**, then double-click **Update accessible devices**.

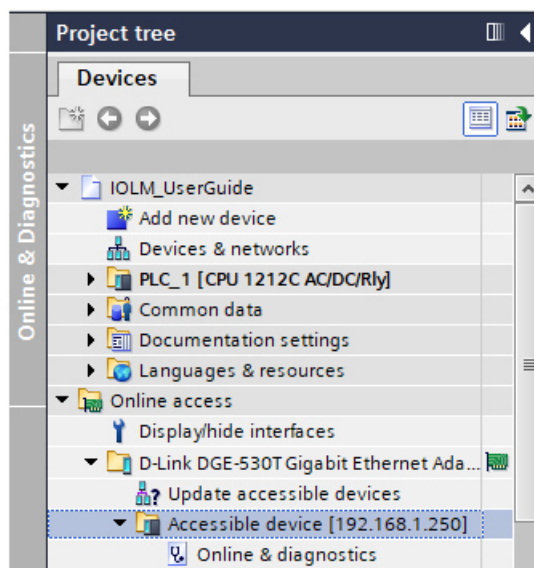

6. Once the accessible devices list is updated, find the IO-Link master by using the default IP address 192.168.1.250 or the previous IP address that the IO-Link master was assigned by IO controller.

7. Double-click the **Accessible device** [192.168.1.250], then double-click the **Online & diagnostics** to open up the Online access view.
8. Click **Functions | Assign IP address**, enter the desired IP configurations. In the following figure, the IO-Link master was configured to use a static IP address 10.0.0.100, subnet mask 255.0.0.0 and no router.
9. Click the Assign IP address button, the IP configuration is assigned to the IO-Link master.

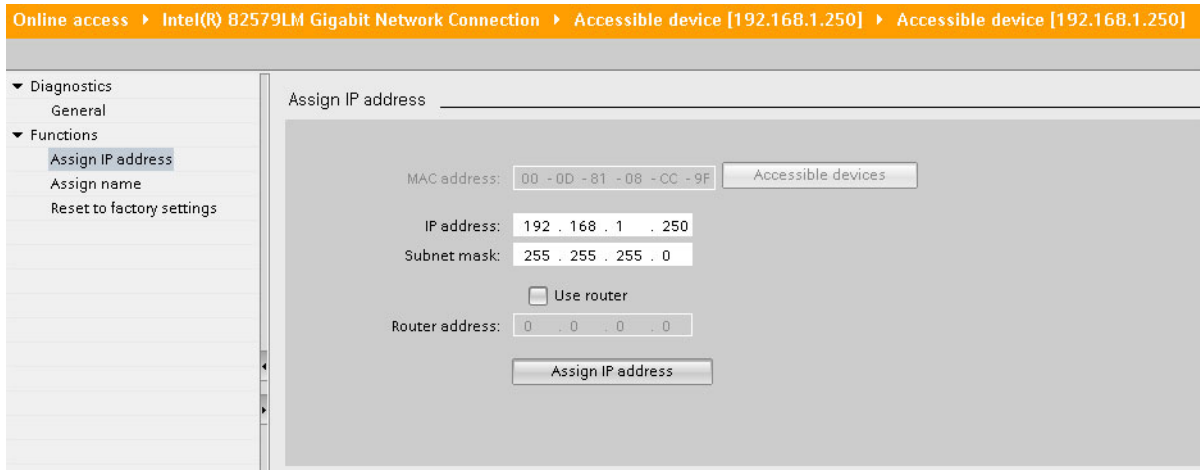

The next configuration step is to assign the device name, go to *Device Name Assignment* on Page 39.

3.4.3.3. Assign IP Address Statically Using the Web Page

You can use the following procedure to configure a static IP address. The IO-Link master web interface switches to the new IP address immediately.

Note: The IO-Link master default IP address is: 192.168.1.250 and the subnet mask is 255.255.255.0. You may need to change your laptop or PC IP address range to access the IO-Link master web interface or you can use PortVision DX to change the IP address without changing your settings.

1. Open a web browser and enter the IO-Link master IP address.
2. Click **Configuration | Network**.
3. Click the **EDIT** button.

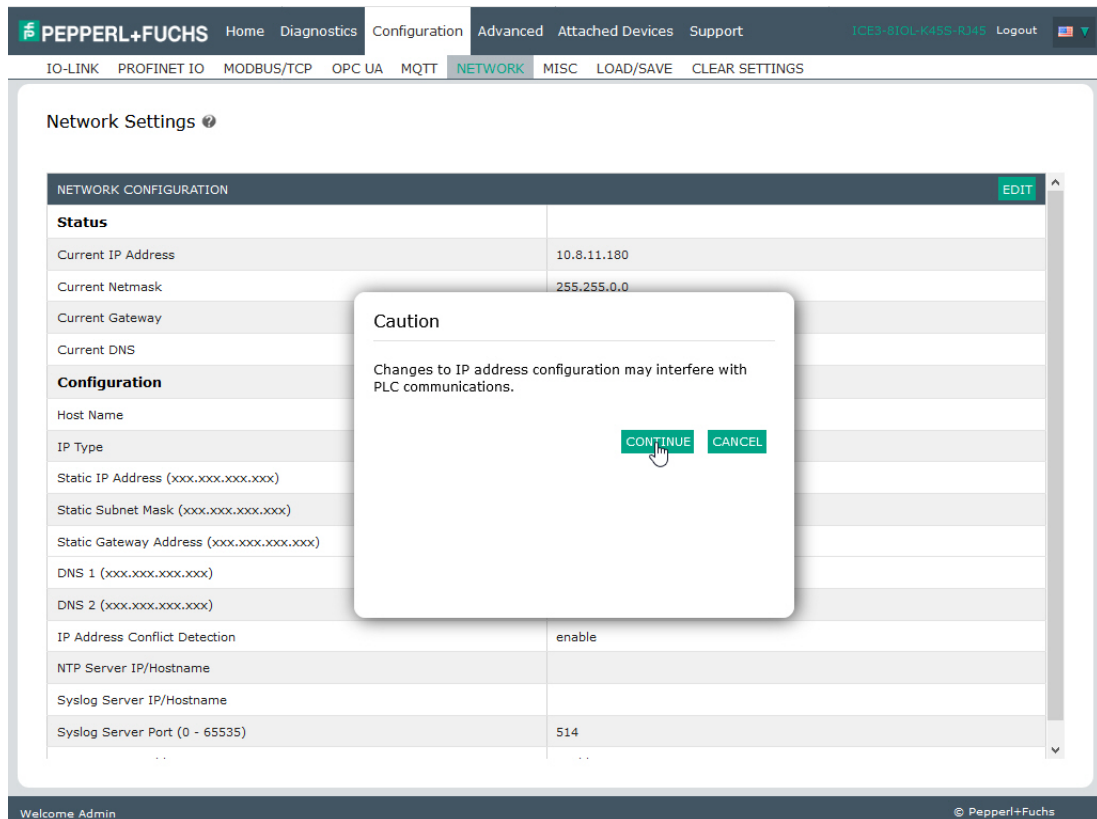

4. If necessary, change the **IP Type** to **static**.
5. Enter an IP address, subnet mask, and gateway address.

6. If applicable, enter the DNS1 and DNS2 addresses.

The screenshot shows the 'Network Settings' page in the Pepperl+Fuchs web interface. The page is titled 'Network Settings' and has a 'NETWORK CONFIGURATION' header. The interface includes a navigation bar with options like 'Home', 'Diagnostics', 'Configuration', 'Advanced', 'Attached Devices', and 'Support'. The 'Configuration' tab is active, and the 'NETWORK' sub-tab is selected. The main content area is a table with two columns: 'Field' and 'Value'. The 'Status' section shows current values for IP Address (10.8.11.180), Netmask (255.255.0.0), Gateway (10.8.0.254), and DNS. The 'Configuration' section includes fields for Host Name, IP Type (set to 'static'), Static IP Address (10.8.11.180), Static Subnet Mask (255.255.0.0), Static Gateway Address (10.8.0.254), DNS 1, DNS 2, and IP Address Conflict Detection (set to 'enable'). A 'SAVE' button is highlighted with a mouse cursor in the top right corner of the configuration area.

NETWORK CONFIGURATION		CANCEL	SAVE
Status			
Current IP Address	10.8.11.180		
Current Netmask	255.255.0.0		
Current Gateway	10.8.0.254		
Current DNS			
Configuration			
Host Name	<input type="text"/>		
IP Type	static		
Static IP Address (xxx.xxx.xxx.xxx)	<input type="text" value="10.8.11.180"/>		
Static Subnet Mask (xxx.xxx.xxx.xxx)	<input type="text" value="255.255.0.0"/>		
Static Gateway Address (xxx.xxx.xxx.xxx)	<input type="text" value="10.8.0.254"/>		
DNS 1 (xxx.xxx.xxx.xxx)	<input type="text"/>		
DNS 2 (xxx.xxx.xxx.xxx)	<input type="text"/>		
IP Address Conflict Detection	enable		

7. Click the **SAVE** button.

The next configuration step is to assign the device name, go to *Device Name Assignment* on Page 39.

3.5. Device Name Assignment

Use one of the following methods to configure the Device Name.

- STEP 7 - refer to the following procedure
- Web interface - see *Using the Web Interface to Assign the Device Name* on Page 40 for information about using the IO-Link master **Configuration | PROFINET IO** page.

3.5.1. Assign the Device Name in STEP 7

Use the appropriate procedure for your environment:

- STEP 7 V5.5
- TIA Portal V13 on Page 40

3.5.1.1. STEP 7 V5.5

Use the following procedure to configure the Device Name using STEP 7.

1. Select the IO-Link master, open the *Edit Ethernet Node* window using the **PLC | Ethernet | Edit Ethernet Node** menu.
2. Click the **Browse** button to open the *Browse Network* window.
The unit should be displayed as an IO-Link master with an empty device name.
3. Select the unit and click the **OK** button to return to the *Edit Ethernet Node* window.

The screenshot shows the 'Edit Ethernet Node' dialog box. It is divided into several sections:

- Ethernet node:** Contains a 'MAC address' field with the value '00-0D-81-08-CC-9F' and a 'Browse...' button.
- Set IP configuration:** Contains radio buttons for 'Use IP parameters' (selected), 'Obtain IP address from a DHCP server', and 'Gateway'. Under 'Gateway', there are radio buttons for 'Do not use router' (selected) and 'Use router' (with an empty 'Address' field).
- Identified by:** Contains radio buttons for 'Client ID', 'MAC address', and 'Device name'. Below is a 'Client ID' field.
- Assign device name:** Contains a 'Device name' field with the value 'ICE38IOL' and an 'Assign Name' button.
- Reset to factory settings:** Contains a 'Reset' button.

At the bottom of the dialog are 'Close' and 'Help' buttons.

4. Set the device name. PROFINET IO Device Names are not case-sensitive. In this example, the device name was set to ICE3-8IOL.

If there is a cyclic communication between the device and an IO controller, the cyclic communication has to be stopped before the device name can be changed.

3.5.1.2. TIA Portal V13

1. Use the same procedure in *TIA Portal V13* on Page 35 to access the **Online access** view.
2. Click **Functions | Assign name**, enter the device name and click the **Assign name** button. PROFINET IO Device Names are not case-sensitive. In this example, the device name was set to **ice3_io-link1**.

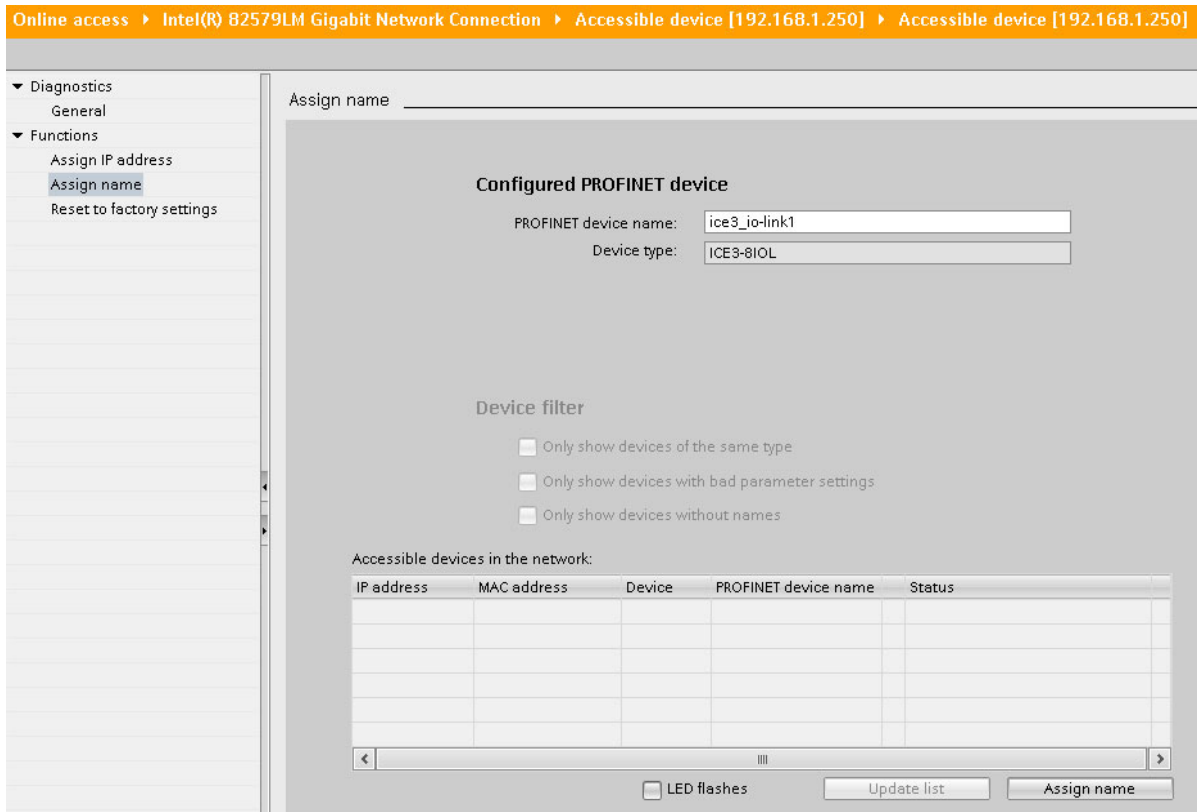

3.5.2. Using the Web Interface to Assign the Device Name

You can use the **Configuration | Profinet IO Settings** page to assign the device name for PROFINET IO with the IO-Link master.

Note: *Changes to device name using the web interface take effect immediately. It may interfere with the communication between the device and IO controller.*

1. If necessary, open the IO-Link master web interface with your web browser using the IP address.
2. Click **Configuration | PROFINET IO Settings**.
3. Click the **EDIT** button.
4. Enter the **PROFINET IO Device Name**.

The **PROFINET IO Device Name** is the same as the name later used to configure PROFINET IO for the IO-Link master. The **PROFINET IO Device Name** is not case-sensitive.

5. If necessary, change the **IOL_CALL Function Block Timeout** (1-20) value to reflect your environment.

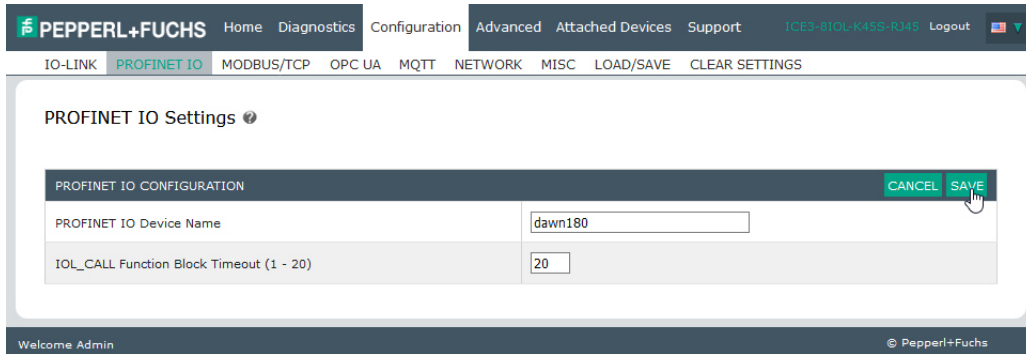

6. Click **SAVE**.

Parameter	Description
PROFINET IO Device Name (Default: empty)	<p>The device name must be specified according to DNS conventions.</p> <ul style="list-style-type: none"> Restricted to a total of 240 characters (letters, digits, dash or period) Parts of the name within the device name; in other words, a string between two periods, must not exceed a maximum of 63 characters. No special characters such as umlauts (ä, ö etc.), brackets, underscore, slash, blank etc. The dash is the only permitted special character. The device name must not begin or end with the "-" character. The device name must not begin with numbers. The device name must not have the structure n.n.n.n (n = 0...999). The device name must not begin with the character string "port-xyz-" (x , y, z = 0...9).
IOL_CALL Function Block Timeout (1-20) (Default: 20)	The timeout value in seconds for IOL_CALL function block.

3.6. Setting the IO Device Update Time

Use the appropriate procedure for your environment:

- STEP 7 V5.5
- TIA Portal V13 on Page 43

3.6.1. STEP 7 V5.5

Use the following procedure to set the IO Device Update Time.

1. Double-click the **Ethernet(1): PROFINET-IO-System (100)**.

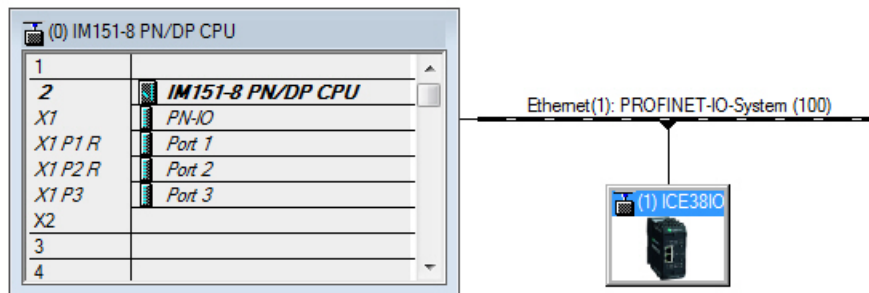

2. In the *Properties - PROFINET IO-System* window, select the **Update Time** tab, as shown in the image below.

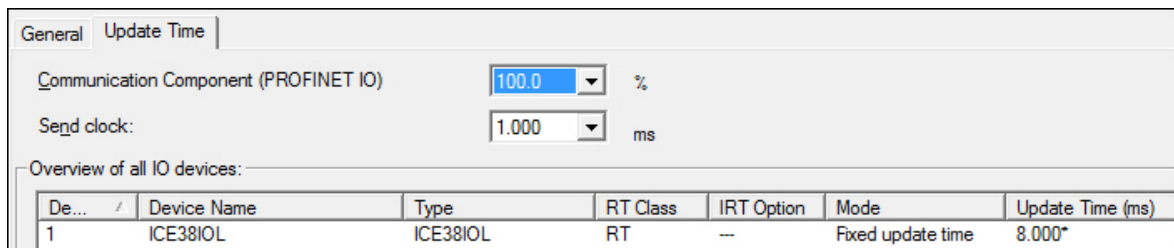

Configuring IO Device Update Timer

3. Set the desired update time. The fastest IO device update time is 8ms.

3.6.2. TIA Portal V13

Use the following procedure to set the IO Device Update Time.

1. Double-click the IO-Link master in the **Device configuration | Network view**.
2. On the **Properties | General tag**, select **PROFINET interface [X1] | Advanced options | Real time settings**.
3. Select the **Can be set** option and set the update time to the desired value from the list. The fastest IO device update time is 8ms.

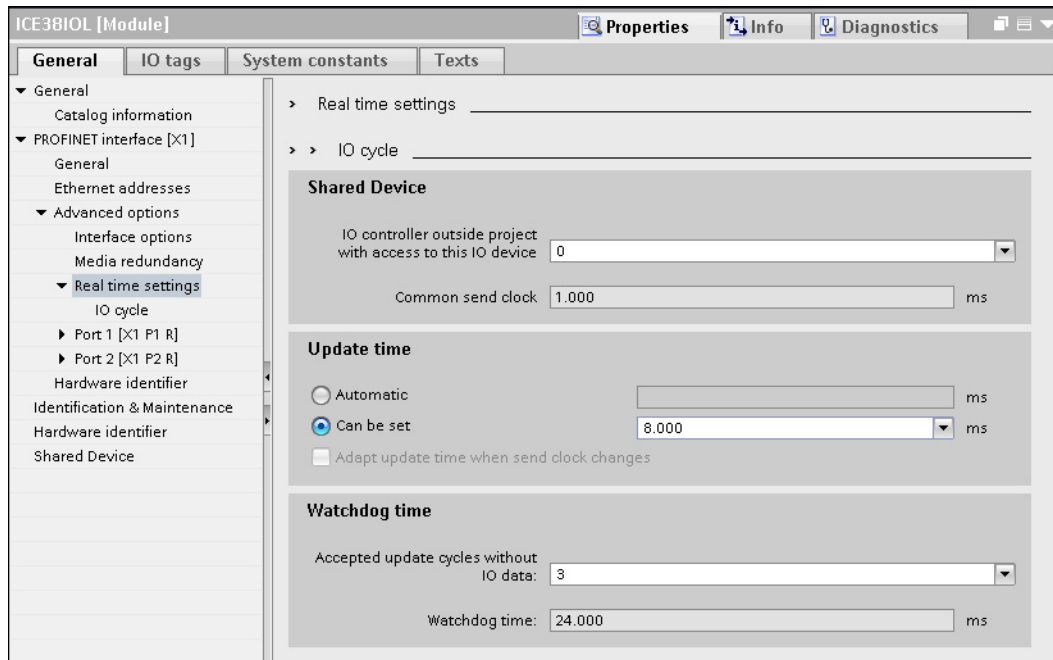

3.7. Configuring IO-Link Ports

The IO-Link master gateway has two categories of IO modules:

- *IO-Link Port Modules* on Page 45
- *Port Status Modules* on Page 53

IO modules are used to configure IO-Link ports and exchange PDI and PDO data with various IO-Link devices and digital I/O devices. The following image shows available modules of the IO-Link master.

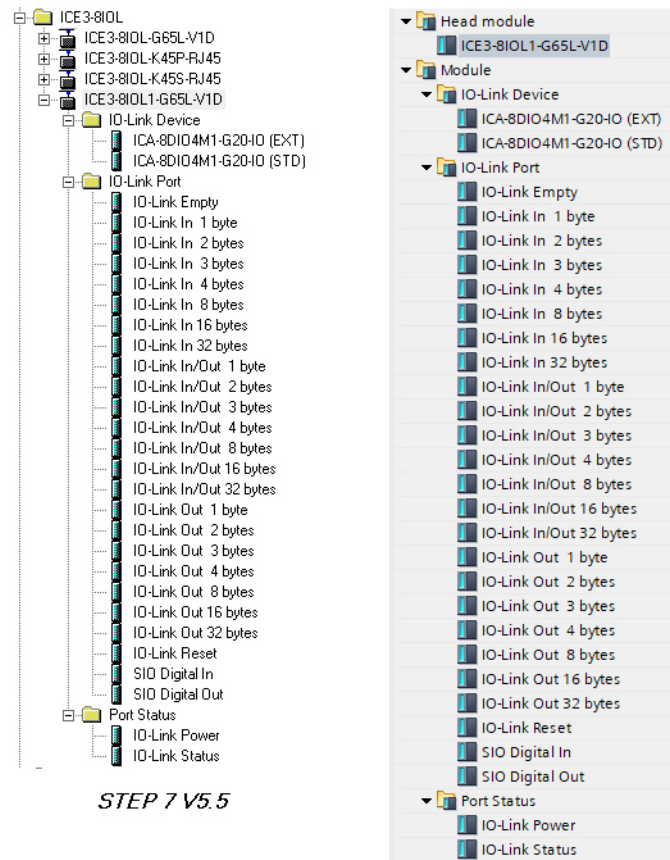

3.7.1. IO-Link Port Modules

An IO-Link port can be configured as one of the following:

- IO-Link Mode
- SIO Digital In Mode
- SIO Digital Out Mode
- Deactivated Mode
- Empty Mode

IO-Link Port modules are used to configure the mode of an IO-Link port.

All the IO-Link modules start with the **IO-Link** (that is: IO-Link In, IO-Link Out and IO-Link In/Out) configure the corresponding IO-Link port as IO-Link Mode. An SIO Digital In module configures the IO-Link port as SIO Digital In Mode. Similarly, an SIO Digital Out module configures the port as SIO Digital Out Mode.

- An **IO-Link module** can be input only, output only or both. In addition, there are different modules with various IO data sizes (1 to 32 bytes). For example, the IO-Link In/Out 4 bytes module is for an IO-Link device that supports up to 4-byte PDI data and 4-byte PDO data. If you do not find an exact matching IO size, select the next size (larger). For instance, use IO-Link in 16-bytes module for an IO-Link device that has 10-byte PDI data. The unused PDI data is filled with zeros.
- For **SIO Digital In module**, the PDI data is fixed at 1-byte. A high voltage on the IO-Link port C/Q Pin results in a 0x01 PDI data; a low voltage on the C/Q Pin results in a 0x00 PDI data.
- For **SIO Digital Out module**, the PDO data is fixed at 1-byte. A zero output value from an SIO Digital Out module sets the IO-Link port C/Q pin to low voltage. Any non-zero output value sets the C/Q pin to high voltage.
- An **IO-Link Reset** module deactivates an IO-Link port.

IO-Link Port Module Input Data Format	
Byte Offset	Description
0	PDI Data Block byte 0
1	PDI Data Block byte 1
...	...
31	PDI Data Block byte 31

IO-Link Port Module Output Data Format	
Byte Offset	Description
0	PDO Data Block byte 0
1	PDO Data Block byte 1
...	...
31	PDO Data Block bytes 31

- An IO-Link Empty module indicates that an IO-Link port should not be used. Plugging an IO-Link device into a port in Empty Mode may trigger an alarm.

IO-Link Port modules are allowed in Slot 1 to 8 on the IO-Link master. Slot 1 corresponds to IO-Link Port 1. Slot 2 is for IO-Link Port 2, so on and so forth. If a slot is unpopulated, the corresponding IO-Link port is not configured. That port uses the previously configured settings, or default settings if it has not been configured before.

3.7.1.1. IO-Link Port Settings (IO-Link Port Module Parameters)

Additional IO-Link port settings can be configured by using module parameters.

Use the appropriate procedure for your environment:

- STEP 7 V5.5 on Page 47
- TIA Portal V13 on Page 48

IO-Link Port Module Parameters	
IO-Link Port Config	
Minimum Cycle Time (Default: 4) Valid range: 4-538ms	The minimum or fastest cycle time at which the IO-Link device may operate. You can leave the Minimum Cycle Time set to the default value and the IO-Link master negotiates with the IO-Link device for its minimum cycle time. The IO-Link Diagnostics page displays the Actual Cycle Time , which is the negotiated cycle time.
Data Storage Config	
Automatic Data Storage Upload Enable Default: Off	When this option is initially set to On , the IO-Link master saves the data storage (if the data storage is empty) from the IO-Link device to that port. Some IO-Link devices update the data storage contents if you use the Teach buttons on the IO-Link device, but that is determined by the IO-Link device manufacturer. Automatic upload occurs when the Automatic Upload Enable option is set to On and one of these conditions exists: <ul style="list-style-type: none"> • There is no upload data stored on the gateway. • The IO-Link device executes a requests_ at upload function (generally because you have changed the configuration via Teach buttons). When a port contains data storage for an IO-Link device and if you attach a device whose Vendor and Device ID do not match, the IO-Link LED on the IO-Link master flashes red to indicate a wrong device is attached. In addition, the IO-Link Diagnostics page displays DV: Wrong Sensor in the IO-Link State field. You should not enable Automatic Upload until after you have configured the IO-Link device attached to the port unless you want to capture the default settings. Refer to <i>Data Storage</i> on Page 124 for more information.
Automatic Data Storage Download Enable Default: Off	The data stored on the IO-Link master port is downloaded to the IO-Link device if: <ol style="list-style-type: none"> 1. This option is selected. 2. The data stored on the IO-Link master port contains the same Vendor ID and Product ID as the IO-Link device connected to the port. 3. The data stored on the IO-Link master port is different than that of the IO-Link device. 4. The IO-Link device requests an upload and the Automatic Upload Enable option is set to Off. If you change configuration parameters on the IO-Link device and want the parameters to remain loaded on the IO-Link device, you must disable the Automatic Download option. If you do not disable Automatic Download, the IO-Link master will reload the data storage on the port to the IO-Link device.

IO-Link Port Module Parameters	
Validation Config	
Device Validation Mode (Default: None)	<p>Device Validation Mode provides these options:</p> <ul style="list-style-type: none"> • None - this disables Device Validation Mode. • Compatible - permits a compatible IO-Link device (same Vendor ID and Device ID) to function on the corresponding port. • Identical - only permits an IO-Link device to function on the corresponding port as defined in the following fields. <ul style="list-style-type: none"> - Vendor ID - Device ID - Serial Number
Vendor Id (0-65535)	This is required if you select a Device Validation Mode other than None .
Device Id (0-16777215)	This is required if you select a Device Validation Mode other than None .
Serial Num	This is required if you select Identical for the Device Validation Mode .
Data Validation Mode (Default: None)	<p>There are three Data Validation Modes:</p> <ul style="list-style-type: none"> • None - no data validation is performed on the port. • Loose - the slave device's PDI/PDO lengths must be less than or equal to the user-configured values. • Strict - the slave device's PDI/PDO lengths must be the same as the user-configured values.
PDI Length (0-32)	This is input length of the PDI data field. This is required if you select a Data Validation Mode other than None .
PDO Length (0-32)	This is input length of the PDO data field. This is required if you select a Data Validation Mode other than None .

3.7.1.1.1. STEP 7 V5.5

Use the following information to configure IO-Link port module parameters.

1. Double-click an IO-Link Port module.
2. Select the **Parameters** table.

Available parameters are shown in this figure and the table (Page 46) describes how to use the parameters.

Parameter	Value
Parameters	
IO-Link Port Config	
Minimum Cycle Time	4
Data Storage Config	
Automatic Upload Enable	Off
Automatic Download Enable	Off
Validation Config	
Device Validation Mode	None
Vendor Id	0
Device Id	0
Serial Num	
Data Validation Mode	None
PDI Length	0
PDO Length	0

3.7.1.1.2. TIA Portal V13

Use the following information to configure IO-Link port module parameters.

1. Open the IO-Link master **Device** view.
2. Click an IO-Link Port module.
3. On the **Properties | General tag**, select **Module parameters**. Available parameters are shown in the following figure and the table (Page 46) describes how to use the parameters.

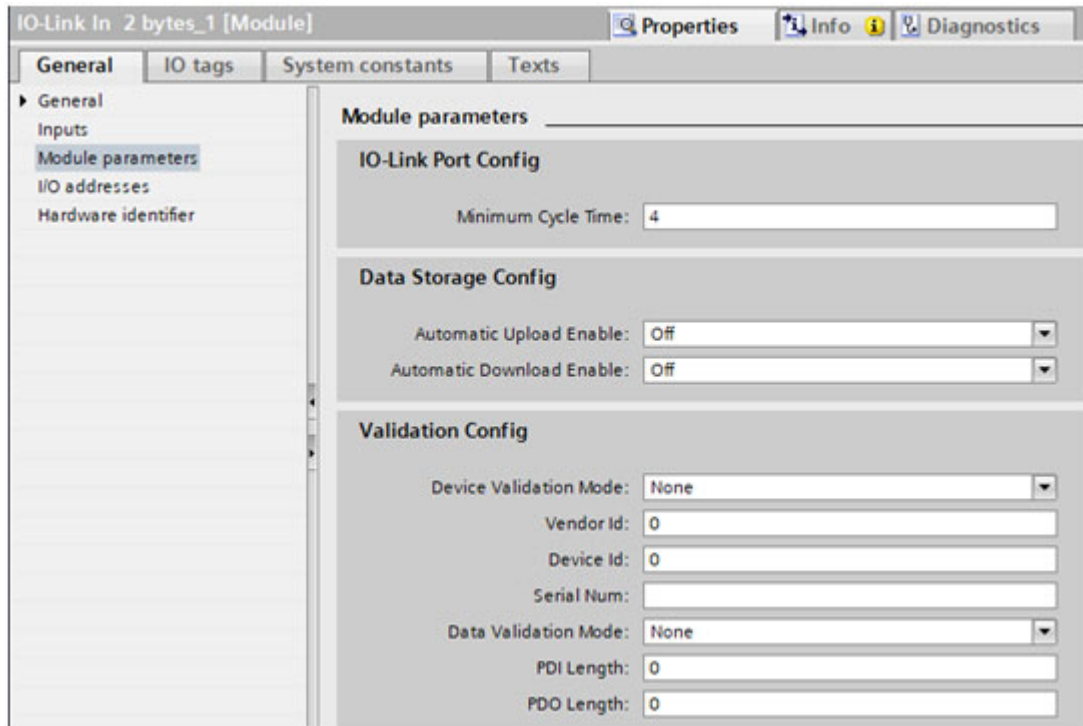

3.7.1.2. SIO Digital In/Out Module Parameters

Use the appropriate procedure to configure SIO digital in/out module parameters.

- STEP 7 V5.5 on Page 49
- TIA Portal V13 on Page 50

SIO Digital Input and Output Module Parameters	
SIO Digital Input	
Invert IO (Default: False)	<p>If enabled, this inverts the I/O value.</p> <ul style="list-style-type: none"> • False (Disabled - Do not invert IO) • True (Enabled - Invert IO) <p>Note: This does not affect the Auxiliary Input.</p>
Input Settling Time (0 - 10000ms) Default= 0ms	<p>If non-zero and Mode is set to Digital-Input, the required time that the input status must remain constant before an input status change is reported.</p>
Input Hold Time (0 - 10000ms) (Default: 0ms)	<p>This is how long the IO-Link master keeps the input at its present value. For example, if the IO-Link master detects the input to go to high, and the hold time is X milliseconds, then the IO-Link master reports the input as high for X milliseconds, even though the input itself may have gone away already. If X is zero, then you get the behavior currently in the field.</p>
SIO Digital Output	
Invert IO (Default: False)	<p>If enabled, this inverts the I/O value.</p> <ul style="list-style-type: none"> • False (Disabled - Do not invert IO) • True (Enabled - Invert IO) <p>Note: This does not affect the Auxiliary Input.</p>
Default Digital Output (Default: Off)	<p>Defines the default digital output value that is used at startup and when there is no active PDO controller.</p> <ul style="list-style-type: none"> • Off (low voltage) • On (high voltage)

3.7.1.2.1. STEP 7 V5.5

Use the following procedure to configure SIO digital in/out module parameters.

1. Double-click an SIO Digital In or SIO Digital Output module.
2. Select the **Parameters** table. Available parameters are shown in the next images and the table (Page 49) describes SIO digital input and output module parameters.

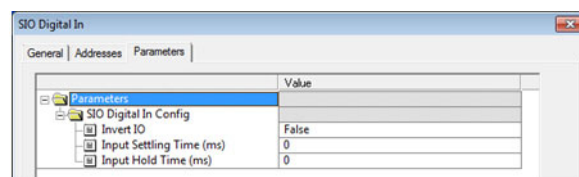

SIO Input Module Parameters

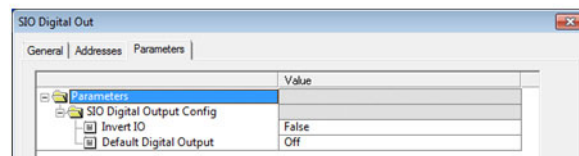

SIO Output Module Parameters

3.7.1.2.2. TIA Portal V13

Use the following procedure to configure SIO digital in/out module parameters.

1. Open the IO-Link master **Device** view. Click an SIO Digital In or SIO Digital Output module.
2. On the **Properties | General tag**, select **Module parameters**. Available parameters are shown in the next images and the table (Page 49) describes SIO digital input and output module parameters.

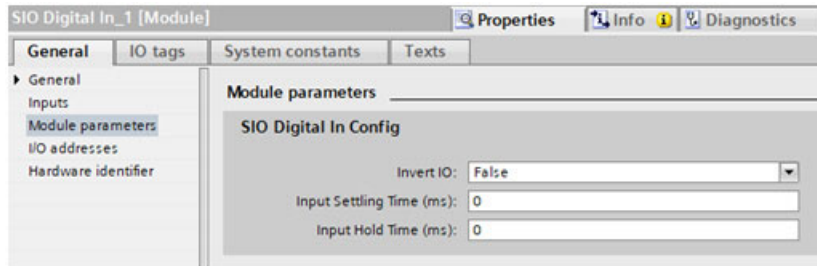

SIO Input Module Parameters

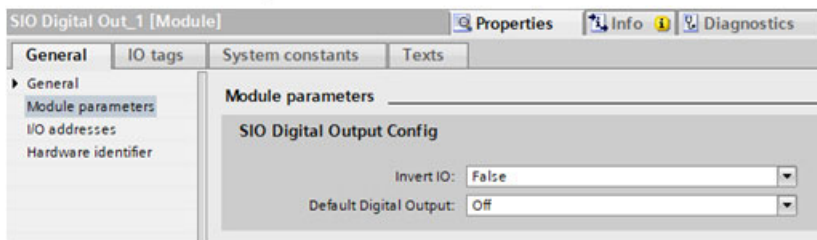

SIO Output Module Parameters

3.7.2. IO-Link Device Modules

In addition to IO-Link modules, IO-Link Device modules can also be used in Slot 1 to 8 on the IO-Link master. When an IO-Link Device module is used, IO-Link master expects the specified IO-Link device, or a compatible device, to be plugged into that port. The IO-Link Device module comes with additional device specific parameters, which can be configured by using module parameters. IO-Link master will be applied the parameters to the device automatically once a PLC connection is established.

Available IO-Link Device modules are:

- ICA-8DIO4M1-G20-IO (STD)
- ICA-8DIO4M1-G20-IO (EXT)

Besides normal IO-Link port settings, device specific settings can be configured by using module parameters. Use the appropriate procedure for your environment:

3.7.2.1. STEP 7 V5.5

Using the following information to configure a IO-Link Device module parameters.

1. Double-click an IO-Link Device module.
2. Select the **Parameters** table.

A sample of available device specific parameters are show in this figure. Please refer to the IO-Link device manual on how to configure and use the parameters.

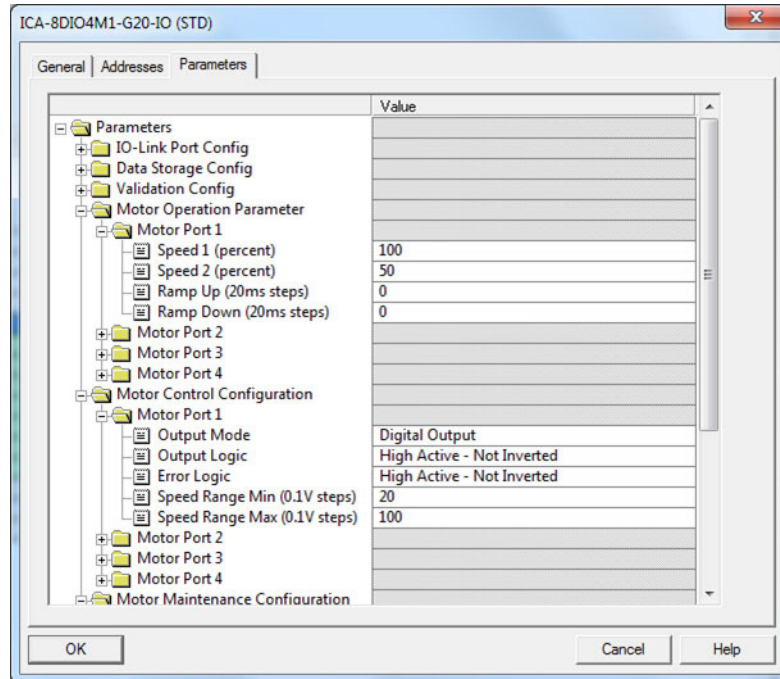

3.7.2.2. TIA Portal V13

Use the following information to configure IO-Link Device module parameters.

1. Open the IO-Link master Device view.
2. Click an IO-Link Device module.
3. **Properties | General** tag, select **Module parameters**.

A sample of available device specific parameters are show in this figure. Please refer to the IO-Link device manual on how to configure and use the parameters.

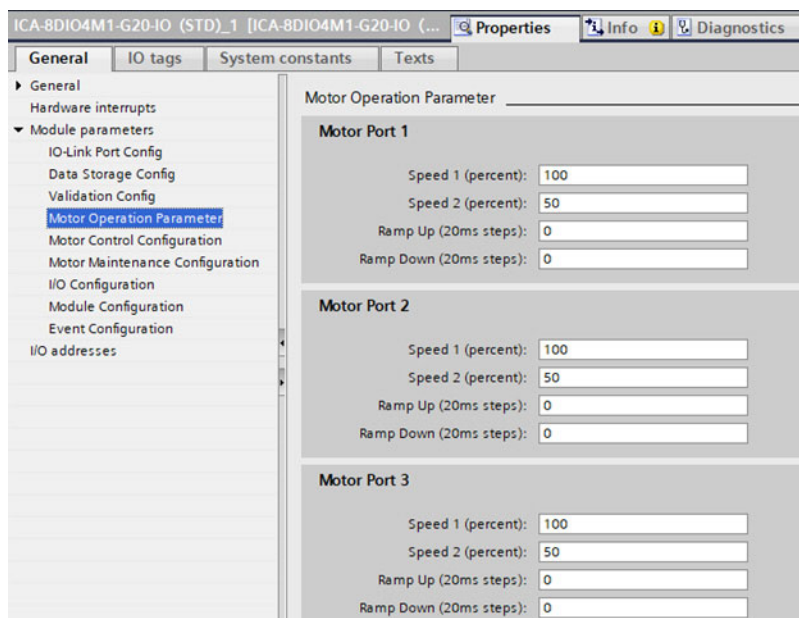

3.7.3. Port Status Modules

There are two **Port Status** modules:

- IO-Link Status Module
- IO-Link Power Module (available on selected models)

3.7.3.1. IO-Link Status Module

IO-Link Status module is a 4-byte input only module that provides status information of all IO-Link ports. The following table shows the data format of IO-Link Status module.

Byte Offset	Status Byte Description
0	IO-Link Active
1	IO-Link PDI Valid
2	IO-Link Auxiliary Input
3	IO-Link Error

Each IO-Link port is mapped into one bit of each byte in the IO-Link Status module as shown in this table.

<i>Bit Map of IO-Link Active, IO-Link Error, and Auxiliary Input Modules</i>								
	Bit 7	Bit 6	Bit 5	Bit 4	Bit 3	Bit 2	Bit 1	Bit 0
Byte 1	Port 8	Port 7	Port 6	Port 5	Port 4	Port 3	Port 2	Port 1

For IO-Link Active status byte (offset 0), a bit one means the corresponding IO-Link port is active. An IO-Link port is considered as active when it is configured correctly and has a working IO-Link device attached.

A bit one in IO-Link PDI Valid status byte (offset 1) means the PDI data from the corresponding IO-Link port is valid. PDI Valid is only applicable to IO-Link port modules that have input data.

- If there are any errors detected when communicating with the IO-Link device, the corresponding bit in the IO-Link Error status byte (offset 2) will be set to 1.
- If a high voltage is detected on the auxiliary input of an IO-Link port, the corresponding bit in the IO-Link Auxiliary Input status byte (offset 3) will be set to 1.

See the following table for the description of each byte of the **IO-Link Status** module.

Status Byte	Status Bit Description
IO-Link Active	<ul style="list-style-type: none"> • 0: IO-Link port is not active, no IO-Link device is detected. • 1: IO-Link port is active, an IO-Link device is detected and operational.
IO-Link PDI Valid	<ul style="list-style-type: none"> • 0: IO-Link port PDI data is not valid. • 1: IO-Link port PDI data is valid.
IO-Link Auxiliary Input	<ul style="list-style-type: none"> • 0: Low voltage detected on the auxiliary pin of an IO-Link port. • 1: High voltage detected on the auxiliary pin of an IO-Link port.
IO-Link Error	<ul style="list-style-type: none"> • 0: No error detected • 1: An error detected. The further information about the error is available in PROFINET IO channel diagnostics.

3.7.3.2. Auxiliary Input Parameters

Use the appropriate procedure for your environment:

- *STEP 7 V5.5*
- *TIA Portal V13* on Page 56

Port N Auxiliary Input Parameters	
Enable (Default: False)	If enabled, the auxiliary input of Port n will be used. <ul style="list-style-type: none"> • True (Enabled – Enable auxiliary input) • False (Disable – Do not use auxiliary input)
Invert Input (Default: False)	If enabled, this inverts the auxiliary input of port n. <ul style="list-style-type: none"> • False (Disabled - Do not auxiliary input) • True (Enabled – Invert auxiliary input)
Input Settling Time (ms) (Default: 0)	The auxiliary input settling time that remains constant before that input is considered/accepted.
Input Hold Time (ms) (Default: 0)	This is how long the IO-Link master keeps the input at its present value. For example, if the IO-Link master detects the input to go to high, and the hold time is X milliseconds, then the IO-Link master reports the input as high for X milliseconds, even though the input itself may have gone away already. If X is zero, then you get the behavior currently in the field.

3.7.3.2.1. STEP 7 V5.5

Use this procedure to set the auxiliary input parameters.

1. Double-click the IO-Link Status module.
2. Select the **Parameters** table. Available parameters are shown in the next image and the table (Page 54) describes Auxiliary Input parameters.

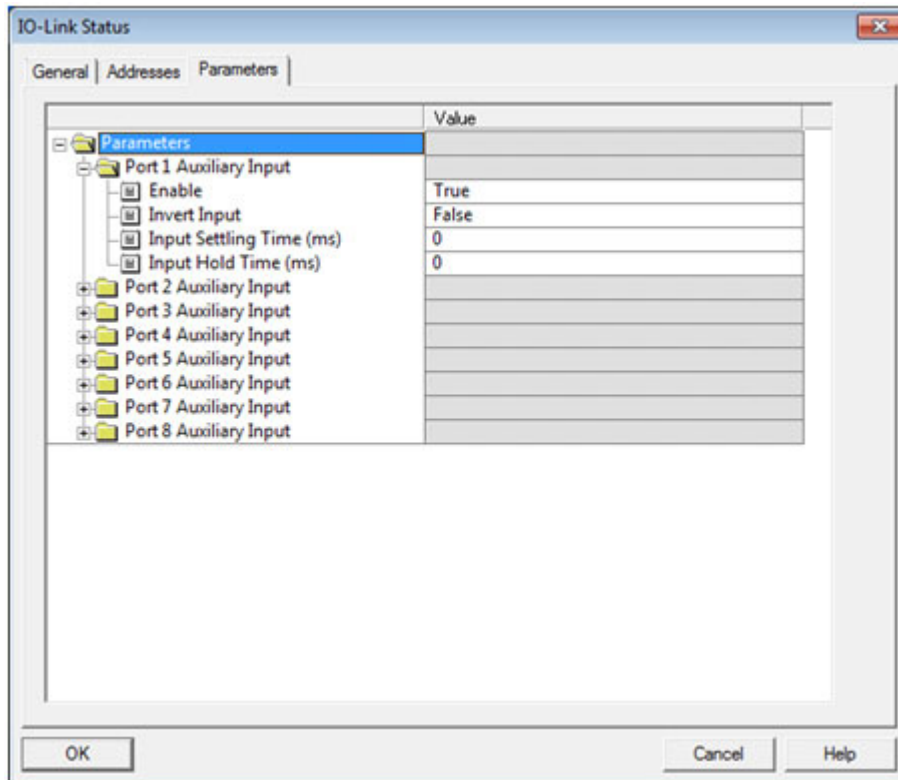

3.7.3.2.2. TIA Portal V13

Use this procedure to set the auxiliary input parameters.

1. Open the IO-Link master **Device** view.
2. Click the **IO-Link Status** module.
3. On the **Properties | General** tag, select **Module parameters**. Available parameters are shown in the next image and the table (Page 54) describes Auxiliary Input parameters.

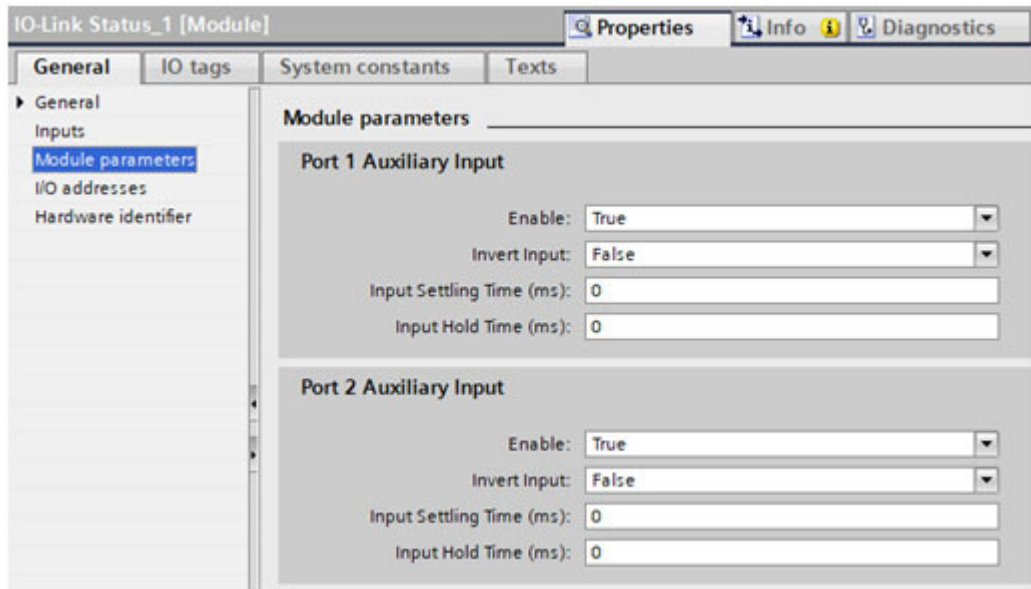

3.7.3.3. IO-Link Power Module (ICE3-8IOL1-G65L-V1D)

Available on modes that support IO-Link Class B ports, such as the ICE3-8IOL1-G65L-V1D, the IO-Link Power module provides status information of 2L+ power supply on the Class B ports. It also allows PLC to control the auxiliary digital output on the Class A ports.

The IO-Link Power module has a 2-byte input, which provides 2L+ power supply status of the Class B IO-Link ports and auxiliary digital output status of the Class A IO-Link ports.

Input Data Format of the IO-Link Power Module

Input Byte	Input Bit Description
Byte 0	For Class B IO-Link ports: <ul style="list-style-type: none"> • 0: 2L+ power supply is disabled • 1: 2L+ power supply is enabled For Class A IO-Link ports: <ul style="list-style-type: none"> • 0: Auxiliary digital output is disabled • 1: Auxiliary digital output is enabled

Input Data Format of the IO-Link Power Module (Continued)

Input Byte	Input Bit Description
Byte 1	For Class B IO-Link ports: <ul style="list-style-type: none"> 0: There is no fault detected on 2L+ power supply 1: There is a fault detected on 2L+ power supply For Class A IO-Link ports: <ul style="list-style-type: none"> 0: There is no fault detected on auxiliary digital output 1: There is a fault detected on auxiliary digital output

Each IO-Link port is mapped into one bit of each byte in the IO-Link Power module. For example, the following table shows the bit map of IO-Link Power module input for ICE3-8IOL1-G65L-V1D.

Bit Map of IO-Link Power Module Input (ICE3-8IOL1-G65L-V1D)

	Bit 7 (Port 8)	Bit 6 (Port 7)	Bit 5 (Port 6)	Bit 4 (Port 5)	Bit 3 (Port 4)	Bit 2 (Port 3)	Bit 1 (Port 2)	Bit 0 (Port 1)
Byte 0	Auxiliary output status	Auxiliary output status	Auxiliary output status	Auxiliary output status	2L+ power supply status	2L+ power supply status	2L+ power supply status	2L+ power supply status
Byte 1	Auxiliary output fault	Auxiliary output fault	Auxiliary output fault	Auxiliary output fault	2L+ power supply fault	2L+ power supply fault	2L+ power supply fault	2L+ power supply fault

For IO-Link Class B ports, Pin 2 is the 2L+ power supply. For IO-Link Class A ports, Pin 2 is the auxiliary digital output. Therefore the input byte 0 of IO-Link Power module provides the current status of an IO-Link port Pin 2. The input byte 1 of IO-Link Power module indicates whether there is a fault detected on Pin 2.

The fault bit will be cleared automatically when the faulty condition is removed. Additionally, for auxiliary digital output, the fault bit will also be cleared when the auxiliary digital output is enabled and set to high by PLC. However, if the faulty condition still exists, the corresponding fault bit will be set again.

IO-Link Power module also has 1-byte output that allows PLC to enable or disable the auxiliary digital output of a Class A IO-Link port. See the following table for the description of the output data format of IO-Link Power module.

Output Byte	Output Bit Description
Byte 0	For Class B IO-Link ports: <ul style="list-style-type: none"> Not used. Writing to the output bit has no effect. For Class A IO-Link ports: <ul style="list-style-type: none"> 0: Disable the auxiliary digital output (pin 2 set to high impedance) 1: Enable the auxiliary digital output (pin 2 set to high)

For model ICE3-8IOL1-G65L-V1D, the following table shows the bit map of IO-Link Power module output.

Bit Map of IO-Link Power Module Output (ICE3-8IOL1-G65L-V1D)

	Bit 7 (Port 8)	Bit 6 (Port 7)	Bit 5 (Port 6)	Bit 4 (Port 5)	Bit 3 (Port 4)	Bit 2 (Port 3)	Bit 1 (Port 2)	Bit 0 (Port 1)
Byte 0	Auxiliary digital output	Auxiliary output status	Auxiliary output status	Auxiliary output status	Not applicable	Not applicable	Not applicable	Not applicable

In order for PLC to actually control an auxiliary digital output, the Auxiliary Output option must be set to True in PLC project using the IO-Link Power module parameters.

3.7.3.3.1. Configuring IO-Link Power Parameters

Use the appropriate procedure for your environment:

- STEP 7 V5.5
- TIA Portal V13

IO-Link Power Output Parameters	
Port n Auxiliary Output Enable (Default: False)	<p>If enabled, PLC controls the auxiliary digital output of Port n through the output of IO-Link Power module.</p> <ul style="list-style-type: none"> • True (Enabled – PLC controls the auxiliary digital output) • False (Disable – PLC does not control the auxiliary digital output)
Port n Auxiliary Output Default Output (Default: Off)	<p>Defines the default auxiliary digital output value that is used at startup and when there is no active PDO controller.</p> <ul style="list-style-type: none"> • Off (high impedance) • On (high voltage) - 24V

STEP 7 V5.5

Use this procedure to set the auxiliary output parameters.

1. Double-click the IO-Link Power module.
2. Select the **Parameters** table. Available parameters are shown in the next image and table *IO-Link Power Output Parameters* on Page 58 describes Auxiliary Output parameters. Only IO-Link ports that have auxiliary digital output are displayed.

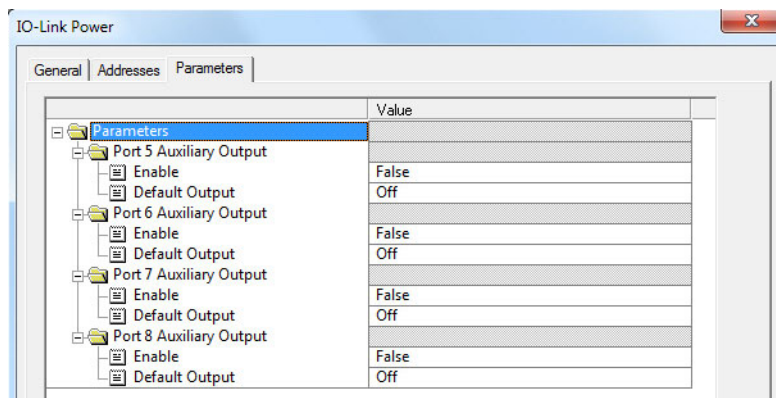

TIA Portal V13

Use this procedure to set the auxiliary input parameters.

1. Open the IO-Link Master **Device** view.
2. Click the **IO-Link Power** module.

- On the **Properties | General** tag, select **Module parameters**. Available parameters are shown in the next image and table *IO-Link Power Output Parameters* on Page 58 describes Auxiliary Output parameters. Only IO-Link ports that have auxiliary digital output are displayed.

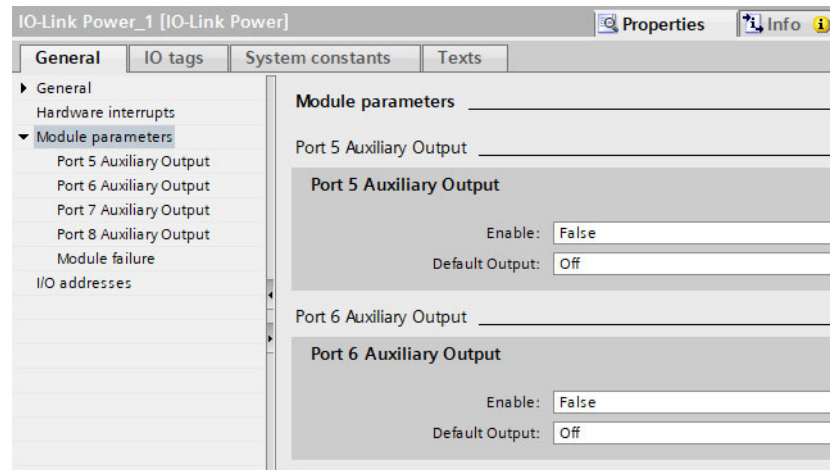

3.7.4. Configuring IO-Link Ports with the Web Interface

IO-Link port settings (for example, port mode, minimum cycle time, data storage, validation, and device validation) should be configured through STEP 7 by adding correct modules and setting modules' parameters. Optionally, the same settings can be changed through the web interface.

Note: Any changes made through the web interface are overwritten when an application relation is established between a gateway and an IO controller.

This page provides special features such as Data Storage, Device Validation, and Data Validation.

Note: Do not configure Data Storage until the IO-Link device is configured. Data Storage, Device Validation, and Data Validation are discussed in Utilizing IO-Link master Features on Page 121.

You can use this procedure to configure IO-Link settings for each IO-Link port.

If an IO-Link device is attached to the port, no configuration is required for operation. If a digital input or output device is attached, it is necessary to change the **Port Mode**.

- If necessary, open the IO-Link master web interface with your web browser using the IP address.
- Click **Configuration | IO-Link Settings**.
- Click the **EDIT** button for the port or ports that you want to configure.

Note: You can click each **EDIT** button and open all ports to quickly configure port parameters.

4. Optionally, enter a friendly port name.

The screenshot shows the 'IO-Link Settings' page with a table for configuring 8 ports. The table has columns for each port (PORT 1 to PORT 8) and rows for various configuration parameters. The 'Port Name' row is highlighted, and a cursor is pointing to the 'SAVE' button for Port 1.

IO-LINK PORT CONFIG	PORT 1	PORT 2	PORT 3	PORT 4	PORT 5	PORT 6	PORT 7	PORT 8
Port Name	Triangulation	IO-Link Port 2	IO-Link Port 3	IO-Link Port 4	IO-Link Port 5	IO-Link Port 6	IO-Link Port 7	IO-Link Port 8
Port Mode	IOLink	IOLink	IOLink	IOLink	IOLink	IOLink	DigitalIn	DigitalOut
PDO Lock Enable	true	true	true	true	true	true	true	true
Invert SIO	false	false	false	false	false	false	false	false
Invert Auxiliary Input	false	false	false	false	false	false	false	false
Default SIO Digital Output State	Off	Off	Off	Off	Off	Off	Off	Off
Minimum Cycle Time (4 - 538)	4 ms	4 ms	4 ms	4 ms	4 ms	4 ms	4 ms	4 ms
Auxiliary Input Settling Time (0 - 10000)	0 ms	0 ms	0 ms	0 ms	0 ms	0 ms	0 ms	0 ms
Auxiliary Input Hold Time (0 - 10000)	0 ms	0 ms	0 ms	0 ms	0 ms	0 ms	0 ms	0 ms
SIO Input Settling Time (0 - 10000)	0 ms	0 ms	0 ms	0 ms	0 ms	0 ms	0 ms	0 ms
SIO Input Hold Time (0 - 10000)	0 ms	0 ms	0 ms	0 ms	0 ms	0 ms	0 ms	0 ms
Data Storage Config								
Storage Contents	empty	empty	empty	empty	empty	empty	empty	empty
Automatic Upload Enable	Off	Off	Off	Off	Off	Off	Off	Off
Automatic Download Enable	Off	Off	Off	Off	Off	Off	Off	Off
Data Storage Manual Ops								
	CLEAR	CLEAR	CLEAR	CLEAR	CLEAR	CLEAR	CLEAR	CLEAR
	UPLOAD			UPLOAD				
	DOWNLOAD			DOWNLOAD				

5. Make appropriate selections for the device that you connected to that port.

Make sure you select the **DigitalIn** option for a digital input device and the **DigitalOut** option for a digital output device for the **Port Mode**.

The IO-Link master negotiates the **Minimum Cycle Time** so it is not necessary to set a cycle time unless you need a specific cycle time.

You can refer to the following table if you require definitions or values for the options.

Note: Do not configure Data Storage until the IO-Link device is configured.

Note: Do not enable **Automatic Download** and then attempt device configuration as Automatic Download changes the settings back to what is stored on the IO-Link master. Data Storage, Device Validation, and Data Validation are discussed in Utilizing IO-Link master Features on Page 121.

6. Click the **SAVE** button for each port.

7. Return to the **IO-Link Diagnostics** page to verify that your changes have taken affect.

The **Configuration | IO-Link Settings** page supports the following options.

IO-LINK Settings Page	
Port Name	User defined port or device description. <ul style="list-style-type: none"> Standard ASCII characters Max length = 80 characters
Port Mode <i>Default: IO-Link</i>	Selected IO-Link port mode. Valid settings are: <ul style="list-style-type: none"> Reset - Select to disable a port or to reset/restart an IO-Link port. IO-Link - Select to connect and operate an IO-Link device on the port. Digital In - Select if a DI device is attached to the port. Digital Out - Select if a DO device is attached to the port.
Invert SIO <i>Default: False</i>	If enabled and the Port Mode is Digital In or Digital Out , this option inverts the SIO value. <ul style="list-style-type: none"> False (Disabled - Do not invert SIO) True (Enabled - Invert SIO) <p>Note: This option does not affect the Auxiliary Input.</p>
Invert Auxiliary Input	If this option is enabled, the Auxiliary bit is inverted.
Default SIO Digital Output State <i>Default: Off</i>	If the port mode is Digital Out , defines the default digital output value that is used at startup and when there is no active PDO controller. <ul style="list-style-type: none"> Off (low voltage) - 0 On (high voltage) - 24V
Default Auxiliary Output State <i>Default: Off</i>	Available on selected models, this option defines the default auxiliary digital output value that is used at startup and when there is no active PDO controller. <ul style="list-style-type: none"> Off (high impedance) On (high voltage) - 24V
Minimum Cycle Time <i>Default: 4</i>	The minimum, or fastest, cycle time at which the IO-Link device may operate. The valid range is 4-538 ms. You can leave the Minimum Cycle Time set to the default value and the IO-Link master negotiates with the IO-Link device for its minimum cycle time. The IO-Link Diagnostics page displays the Actual Cycle Time , which is the negotiated cycle time.
Auxiliary Input Settling Time (0 - 10000)	The auxiliary input settling time that remains constant before that input is considered/accepted
Auxiliary Input Hold Time (0 - 10000)	This is how long the IO-Link master keeps the input at its present value. For example, if the IO-Link master detects the input to go to high, and the hold time is X milliseconds, then the IO-Link master reports the input as high for X milliseconds, even though the input itself may have gone away already. If X is zero, then you get the behavior currently in the field.
SIO Input Settling Time (0 - 10000)	The SIO input settling time that remains constant before that input is considered/accepted.
SIO Input Hold Time (0 - 10000)	This is how long the IO-Link master keeps the input at its present value. For example, if the IO-Link master detects the input to go to high, and the hold time is X milliseconds, then the IO-Link master reports the input as high for X milliseconds, even though the input itself may have gone away already. If X is zero, then you get the behavior currently in the field.

IO-LINK Settings Page (Continued)	
Data Storage Config	
Storage Contents	Indicates that the data storage for the port is empty or displays the Vendor ID and Product ID of the data stored on that port.
Automatic Data Storage Upload Enable <i>Default: Off</i>	<p>When this option is initially set to On, the IO-Link master saves the data storage parameters (if the data storage is empty) from the IO-Link device to the IO-Link master.</p> <p>Automatic upload occurs when the Automatic Upload Enable option is set to On and one of these conditions exists:</p> <ul style="list-style-type: none"> • There is no upload data stored on the gateway and the IO-Link device is connected to the port. • The IO-Link device has the DS_upload bit on (generally because you have changed the configuration via Teach buttons or web page). <p>When a port contains data storage for an IO-Link device and if you attach a device whose Vendor and Device ID do not match, the IO-Link LED on the IO-Link master flashes red to indicate a wrong device is attached. In addition, the IO-Link Diagnostics page displays DS: Wrong Sensor in the IOLink State field.</p> <p>Note: <i>Not all device parameters are sent to data storage, this is determined by the IO-Link device manufacturer.</i></p>
Automatic Data Storage Download Enable <i>Default: Off</i>	<p>The data storage parameters on the IO-Link master are downloaded to the connected IO-Link device if:</p> <ol style="list-style-type: none"> 1. The Automatic Download option is enabled. 2. The data stored on the IO-Link master port contains the same Vendor ID and Product ID as the IO-Link device connected to the port. 3. Data storage parameters are also downloaded to the IO-Link device if configuration changes are made on the device causing the DS_upload bit to turn on and automatic upload is not enabled. 4. The IO-Link device requests an upload and the Automatic Upload Enable option is set to Off. <p>If you change configuration parameters on the IO-Link device and want the parameters to remain loaded on the IO-Link device, you must disable the Automatic Download option. If you do not disable Automatic Download, the IO-Link master will reload the data storage on the port to the IO-Link device.</p>
Data Storage Manual Ops	<p>The Manual Data Storage Ops option provides the following functionality, if data storage is supported by the IO-Link device.</p> <ul style="list-style-type: none"> • CLEAR - this clears any stored data for an IO-Link device on this port. • UPLOAD - this uploads and stores the IO-Link device configuration on the IO-Link master. • DOWNLOAD - this downloads the stored IO-Link device configuration from the IO-Link master to the IO-Link device attached to this port if the Vendor ID and Device ID match.

IO-LINK Settings Page (Continued)	
Validation Config	
Device Validation Mode (Default: None)	<p>Device Validation Mode provides these options:</p> <ul style="list-style-type: none"> • None - this disables Device Validation Mode. • Compatible - permits a compatible IO-Link device (same Vendor ID and Device ID) to function on the corresponding port. • Identical - only permits an IO-Link device to function on the corresponding port as defined in the following fields. <ul style="list-style-type: none"> - Vendor ID - Device ID - Serial Number <p>Note: <i>Connecting an IO-Link device that is different than the configured with Data Validation enabled will generate a DV: wrong sensor error.</i></p>
Vendor Id (0-65535)	<p>This is required if you select a Device Validation Mode other than <i>None</i>.</p> <p>The Vendor ID can be manually entered in this field or click the GET ATTACHED button and the IO-Link master populates the Vendor ID in this field.</p>
Device Id (0-16777215)	<p>This is required if you select a Device Validation Mode other than <i>None</i>.</p> <p>The Device ID can be manually entered in this field or click the GET ATTACHED button and the IO-Link master populates the Device ID in this field.</p>
Serial Num	<p>This is required if you select Identical for the Device Validation Mode.</p> <p>The Serial Number can be manually entered in this field or click the GET ATTACHED button and the IO-Link master populates the serial number in this field.</p>
Data Validation Mode (Default: None)	<p>There are three Data Validation Modes:</p> <ul style="list-style-type: none"> • None - no data validation is performed on the port. • Loose - the slave device's PDI/PDO lengths must be less than or equal to the user-configured values. • Strict - the slave device's PDI/PDO lengths must be the same as the user-configured values.
PDI Length (0-32)	<p>This is input length of the PDI data field.</p> <p>This is required if you select a Data Validation Mode other than <i>None</i>.</p> <p>The PDI Length can be manually entered in this field or click the GET ATTACHED button and the IO-Link master populates the PDI length in this field.</p>
PDO Length (0-32)	<p>This is input length of the PDO data field.</p> <p>This is required if you select a Data Validation Mode other than <i>None</i>.</p> <p>The PDO Length can be manually entered in this field or click the GET ATTACHED button and the IO-Link master populates the PDO length in this field.</p>
GET ATTACHED (Button)	<p>After opening a port for editing, you can click the GET ATTACHED button to automatically populate the following fields with data from the IO-Link device:</p> <ul style="list-style-type: none"> • Vendor Id • Device Id • Serial Num • PDI Length • PDO Length

3.8. Configuring other Settings and Diagnosis

The IO-Link master head module has additional module parameters that can be used to configure other features and settings.

3.8.1. Configuring OPC UA Settings

Please refer to *OPC UA Settings Parameters* on Page 97 for information about the OPC UA settings. Use the appropriate procedure for your environment:

3.8.1.1. STEP 7 V5.5

Use the following information to configure OPC UA settings.

1. Double-click the head module.
2. Select the **Parameters** table. Available parameters are shown in this figure and the table OPC UA Settings Page (Page 97) describes how to use the parameters.

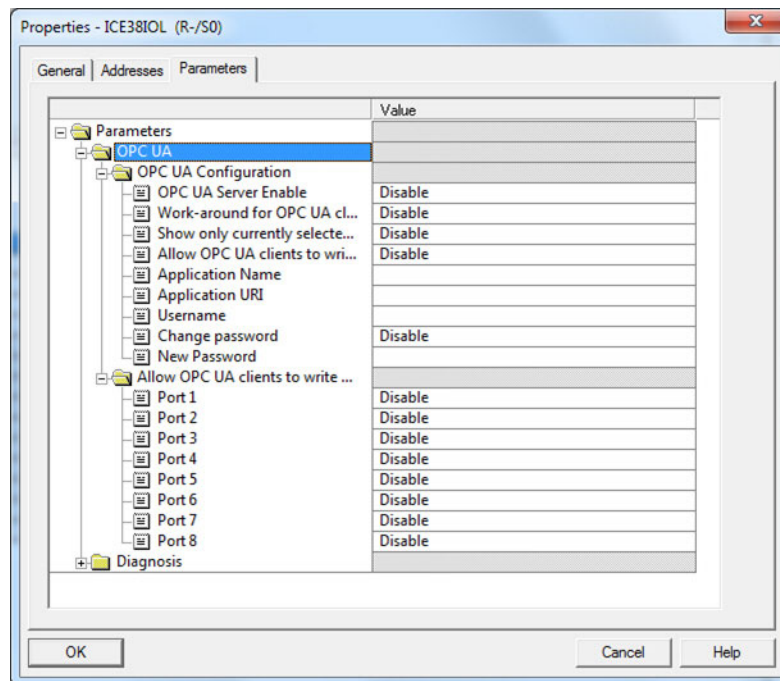

3.8.1.2. TIA Portal V13

Use the following information to configure OPC UA settings.

1. Open the IO-Link master **Device** view.
2. Click the head module.

- On the **Properties | General** tag, select Module parameters. Available parameters are shown in the following figure and the table OPC UA Settings Page (Page 97) describes how to use the parameters.

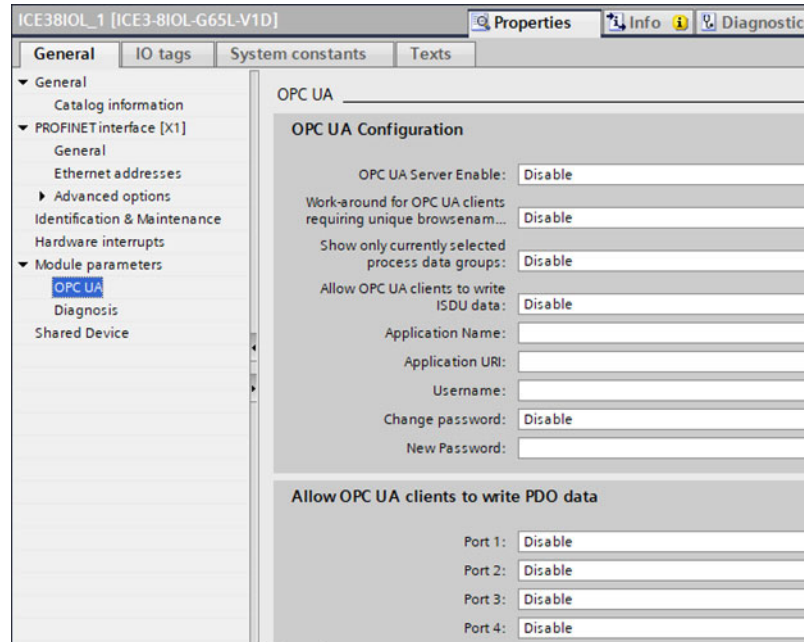

3.8.2. Configuring Diagnosis Settings

Additional diagnosis settings can be configured by using head module parameters. Use the appropriate procedure for your environment:

- STEP 7 V5.5
- TIA Portal V13

Diagnosis Settings	
General Diagnosis Settings	
Report alarms (Default: Enable)	If enabled, report all alarms <ul style="list-style-type: none"> Enable – All alarms enabled Disable – All alarms disabled
Report IO-Link Master alarms (Default: Enable)	If enabled, report alarms from IO-Link master <ul style="list-style-type: none"> Enable – IO-Link master alarms enabled Disable – IO-Link master alarms disabled
Report IO-Link Device error alarms (Default: Enable)	If enabled, report error type alarms from IO-Link device <ul style="list-style-type: none"> Enable – IO-Link device error alarms enabled Disable – IO-Link device error alarms disabled

Diagnosis Settings (Continued)	
Report IO-Link Device warning alarms (Default: Enable)	If enabled, report warning type alarms from IO-Link device <ul style="list-style-type: none"> • Enable – IO-Link device warning alarms enabled • Disable – IO-Link device warning alarms disabled
Report IO-Link Device notification alarms (Default: Enable)	If enabled, report notification type alarms from IO-Link device <ul style="list-style-type: none"> • Enable – IO-Link device notification alarms enabled • Disable – IO-Link device notification alarms disabled
IO-Link Device Diagnosis	
Port n (Default: Enable)	If enabled, report alarms from Port n <ul style="list-style-type: none"> • Enable – alarms from Port n enabled • Disable – alarms from Port n disabled

3.8.2.1. STEP 7 V5.5

Use the following information to configure diagnosis settings.

1. Double-click the head module.
2. Select the **Parameters** table.

Available parameters are shown in this figure and the table Diagnosis Settings on Page 65 describes how to use the parameters.

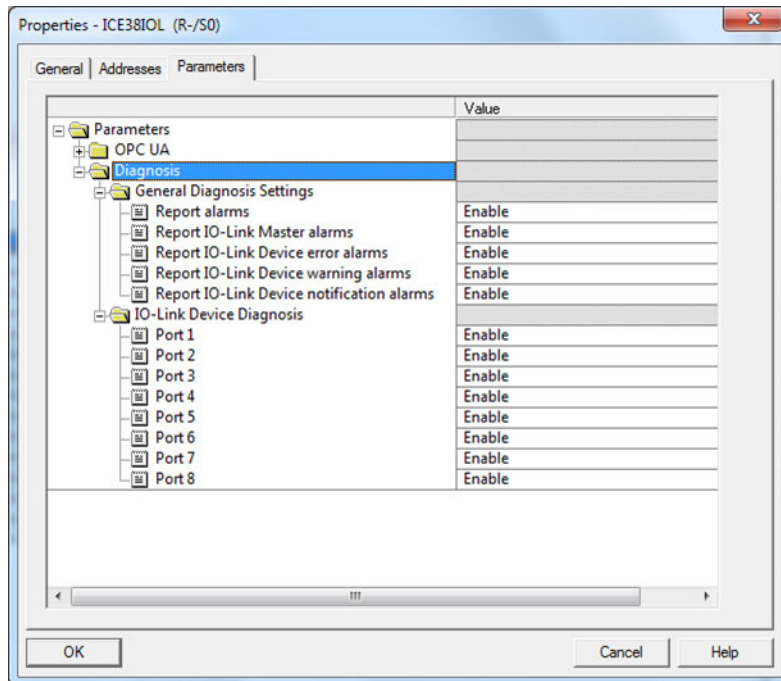

3.8.2.2. TIA Portal V13

Use this procedure to configure diagnosis settings.

1. Open the IO-Link Master **Device** view.
2. Click the head module.
3. On the **Properties | General** tag, select **Module parameters**. Available parameters are shown in the next image and table Diagnosis Settings on Page 65 describes how to use the parameters.

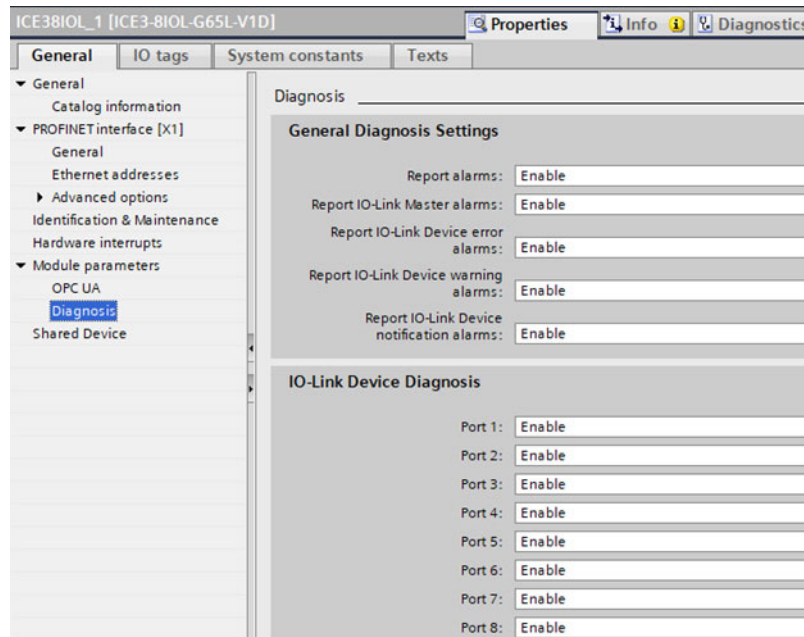

4. Updating Images and Applications

This chapter provides an overview of the software (images and applications) on the IO-Link master. In addition it contains procedures to update images (Page 71) and application sub-assemblies (Page 72).

After verifying that the IO-Link master contains the latest software, the next step is to configure the port characteristics using *Configuring the IO-Link master* on Page 27.

4.1. Images and Application Sub-Assemblies Overview

The IO-Link master is loaded with the latest images at the factory but you may need to update images or application sub-assemblies to have access to the latest features. You can view all image and application versions in the IO-Link master **ADVANCED | Software** page.

The screenshot shows the 'Software' page in the IO-Link master web interface. The page is divided into two main sections: 'IMAGES' and 'APPLICATIONS'. Each section contains a table with columns for the component name and its version number. In the 'IMAGES' section, each row has an 'UPDATE' button. At the bottom of the page, there is an 'Update Application' section with a file browser, an 'Install' button, and a 'REBOOT' button.

IMAGES	
U-Boot Bootloader	1.39
FPGA	1.01
System - Primary	1.56
System - Backup	1.56
Application Base	1.6.36

APPLICATIONS	
application-manager	1.6.0.3
configuration-manager	1.6.0.3
discovery-protocol	1.6.0.2
event-log	1.6.0.0
iolink-driver	1.6.0.12
libiolinkutils	1.6.0.25
modbus	1.6.1.17
mqtt	1.6.0.8
opcua-server	1.6.0.6
profinetio	1.6.2.5
web-help	1.6.0.0
web-user-interface	1.6.0.34b

Update Application
 Browse... No file selected. Install REBOOT

Optionally, you can use PortVision DX to load all images or application sub-assemblies.

Note: *PortVision DX displays the main application base version, which in this case is PROFINET IO. Use the Software page to determine other image or application versions.*

2022-12

4.1.1. Images

The following table discusses IO-Link master images.

IO-Link master Images	
U-Boot Bootloader	<p>U-Boot is a high-level Bootloader that has networking and console command line capabilities. Among other things, it implements a TFTP server and Pepperl+Fuchs new discovery protocol.</p> <p>This verifies that a Linux kernel image exists in NAND, then copies it to RAM and starts the IO-Link master. The U-Boot version is displayed after the image name.</p>
FPGA	<p>The FPGA partition/image contains configuration data used by programmable hardware within the IO-Link master unit.</p> <p>FPGA images are unique to the hardware and protocol type. Make sure you download the correct image for your platform.</p>
ulmage - Primary/Backup	<p>The ulmage contains the Linux kernel and the RAM-resident root file system. It does not contain industrial protocol support or application-specific features.</p> <p>There is a Primary and Backup version loaded on the IO-Link master. The IO-Link master automatically reloads the Backup ulmage if the file system corrupted.</p> <p>The ulmage version is displayed after the Primary/Backup ulmage.</p>
Application Base	<p>The Application Base image comprises a flash-resident file system containing applications and protocol support.</p> <p>The Application Base is built from a collection of application subassemblies -- each of which may be updated individually between releases of the application base as a whole.</p> <p>The application sub-assemblies in the Application Base image are displayed in the lower portion of the Software page.</p> <p>The Application Base assembly has a 3-tuple version number: (for example, 1.6.36).</p>

4.1.2. Application Sub-assemblies

Application sub-assemblies are the components of the Application Base image. Application sub-assemblies have a 4-tuple version number (for example, 1.3.18.3). The first two values in a sub-assembly version correspond to the version of the application base assembly for which it was built and tested.

For example, a sub-assembly with version 1.3.18.3 was tested with application base version 1.3.18. When using the **Software** page or PortVision DX, an application sub-assembly can install only if its version number matches that of the installed application base assembly. A sub-assembly with a version of 1.20.2.4 only installs if the application base version is 1.20.2. It will not install on a device with application base version 1.21.5.

IO-Link master Application Sub-assemblies	
application-manager	The Application Manager version loaded on the IO-Link master.
configuration-manager	The Configuration Manager version loaded on the IO-Link master.
discovery-protocol	The Discovery Protocol version loaded on the IO-Link master.
event-log	The Event log version loaded on the IO-Link master.
iolink-driver	The IO-Link driver version loaded on the IO-Link master.
libiolinkutils	The IO-Link utilities library version loaded on the IO-Link master.
modbus	Modbus/TCP interface version loaded on the IO-Link master.
mqtt	If applicable, the MQTT interface version loaded on the IO-Link master.
opcua-server	If applicable, the opcua-server interface version loaded on the IO-Link master.
profinetio	The PROFINET IO version loaded on the IO-Link master.
web-help	If applicable, the web-help system version loaded on the IO-Link master.
web-user-interface	The web-user interface version loaded on the IO-Link master

4.2. Using the Web Interface to Update Software

The upper portion of the **Advanced | Software** page is used to update the IO-Link master images. The lower portion of this page is used for updating application sub-assemblies that are integrated in the Application Base.

Typically, the latest application sub-assemblies are available in the Application Base image. There may times when a feature enhancement or bug fix is available in an application sub-assembly and not yet available in the Application Base image.

4.2.1. Updating Images

Use this procedure to upload images or images using the **Software** page.

1. Download the latest image or images from <https://www.pepperl-fuchs.com>.

Note: Make sure that you download the appropriate software for your model. For example, the FPGA images are unique for different hardware models and protocol.

2. Open your browser and enter the IP address of the IO-Link master.
3. Click **Advanced | SOFTWARE**.
4. Click the **UPDATE** button next to the image you want to update.
5. Click the **Browse** button, navigate to the file location, highlight the image, and click **Open**.
6. Click the **Install** button.

The screenshot shows the 'Software' page in the Pepperl+Fuchs web interface. The page is divided into two main sections: 'IMAGES' and 'APPLICATIONS'. The 'IMAGES' section contains a table with the following data:

Image Name	Version	Action
U-Boot Bootloader	1.39	UPDATE
FPGA	0.23	UPDATE
System - Primary	1.56	UPDATE
System - Backup	1.43	UPDATE
Application Base	1.6.36a	UPDATE

The 'APPLICATIONS' section contains a list of application sub-assemblies:

- application-manager
- configuration-manager
- discovery-protocol
- event-log
- iolink-driver
- libiolinkutils
- modbus
- mqtt
- opcua-server
- profinetio
- web-help (1.6.0.0)
- web-user-interface (1.6.0.34b)

An 'Update Image: Application Base In Progress' dialog box is displayed over the 'APPLICATIONS' section. The dialog box contains the following text:

Update Image: Application Base
In Progress

You are about to install application-base-pnio-1.6.36a.uImage

It will replace any existing version of that package or image.

Do NOT disconnect power during the installation process.

Buttons: CONTINUE, CANCEL

At the bottom of the page, there is an 'Update Application' section with a 'Browse...' button (No file selected.), an 'Install' button, and a 'REBOOT' button.

2022-12

7. Click the **CONTINUE** button to the *Update Image* message.
 8. Click **OK** to close the *Update Image Successful* message.
- Note:** Some images may require the IO-Link master web server to restart.

4.2.2. Updating Application Subassemblies

Use this procedure to upload applications using the **Software** page.

1. Download the latest application from <https://www.pepperl-fuchs.com>.
2. Open your browser and enter the IP address of the IO-Link master.
3. Click **Advanced** and **SOFTWARE**.
4. Click the **Browse** button under **Update Application** navigate to the file location, highlight the application, and click **Open**.
5. Click the **Install** button.
6. Click the **CONTINUE** button to the *Update Application* message.

The screenshot shows the Pepperl+Fuchs web interface. The top navigation bar includes 'Home', 'Diagnostics', 'Configuration', 'Advanced', 'Attached Devices', and 'Support'. The 'SOFTWARE' tab is selected. Below the navigation, there are sections for 'IMAGES' and 'APPLICATIONS'. The 'IMAGES' section contains a table with columns for name, version, and an 'UPDATE' button. The 'APPLICATIONS' section contains a table with columns for name and version. A modal dialog box titled 'Update Application In Progress' is displayed over the 'APPLICATIONS' table. The dialog contains the following text: 'You are about to install Pepperl+Fuchs-web-user-interface_1.6.0.34b_arm.ipk', 'It will replace any existing version of that package or image.', and 'Do NOT disconnect power during the installation process.' At the bottom of the dialog are 'CONTINUE' and 'CANCEL' buttons. Below the dialog, the 'Update Application' section shows a 'Browse...' button, the text 'No file selected.', an 'Install' button, and a 'REBOOT' button.

IMAGES		
U-Boot Bootloader	1.39	UPDATE
FPGA	0.23	UPDATE
System - Primary	1.56	UPDATE
System - Backup	1.43	UPDATE
Application Base	1.6.36a	UPDATE

APPLICATIONS	
application-manager	
configuration-manager	
discovery-protocol	
event-log	
iolink-driver	
libiolinkutils	
modbus	
mqtt	
opcua-server	
profinetio	
web-help	1.6.0.0
web-user-interface	1.6.0.34b

Update Application

Browse... No file selected. Install REBOOT

7. Click **OK** to close the *Update Application Successful* message.

5. Connecting Devices

This chapter discusses connecting devices to the IO-Link master. Use the appropriate discussion for your IO-Link master model.

- *Overview*
- *ICE3-8IOL-G65L-V1D IO-Link Ports on Page 74*
- *ICE3-8IOL1-G65L-V1D IO-Link Ports on Page 76*
- *ICE3-8IOL-K45P-RJ45 IO-Link Ports on Page 78*
- *ICE3-8IOL-K45S-RJ45 IO-Link Ports on Page 79*

5.1. Overview

The **C/Q** pin for the IO-Link ports in SIO mode for all models:

- **DI** – sinking input
The **DI** pin on the IO-Link ports for all models is a sinking input.
- **DO** – PNP/NPN (push/pull) output

The following table provides definitions of the terminology used above.

Term	Definition
PNP output	Is an output that can source current. That is; the (+) side of the device is connected to the output and the (-) side of the device is connected to (-) of the supply. The device is powered when the output LED is on.
NPN output	Is an output that sinks current. That is: the (-) of the device is connected to the output and the (+) side of the device is connected to (+) side of the supply. The device is powered when the output LED is off.
Sinking input	Sinks current into the IO-Link master so a positive voltage will cause the input to turn on. Note: <i>Using NPN with inputs is not correct as NPN described an output situation – however some vendors describe their inputs as accepting a certain type of sensor output - so in this case a sinking input will accept a PNP output sensor.</i>

5.2. ICE3-8IOL-G65L-V1D IO-Link Ports

The ICE3-8IOL-G65L-V1D provides eight IO-Link ports with M12, 5-pin female/A coded connectors. Each port has robust over-current protection and short circuit protection on its L+/L- power output and C/Q IO-Link signal. The pin-out for each IO-Link port is per the IO-Link standard and is provided in the following table:

This table provides signal information for the IO-Link connectors.

Pin	Signal	Description
1	L+	IO-Link device power supply (+24V)
2	DI	Digital input
3	L-	IO-Link device power supply (0V)
4	C/Q	Communication signal, which supports SDCl (IO-Link) or SIO (standard input/output) digital I/O
5	FE	Functional Earth (electronics wiring)

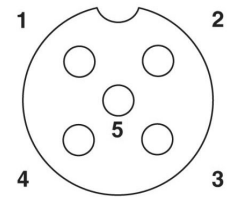

The standard SDCl (IO-Link) transmission rates are supported:

- COM1 at 4.8Kbps
- COM2 at 38.4Kbps
- COM3 at 230.4Kbps

There are active over-current limiter electronics for each port in the ICE3-8IOL-G65L-V1D that detects the overload/short-circuit condition within a few milliseconds and shuts off the output power to protect the port and the devices connected to it. The port's power output self-recovers and restores to normal immediately after the overload or short-circuit condition is removed.

The over-current limiter circuit for L+/L- pins is separate circuits than the over-current limiter circuit for the C/Q output pin. When a port is affected by overload/short-circuit condition, it does not affect the operation of the other ports. All other ports will continue to operate normally without any glitch or interruption. The current output capacity, cutoff current, and power sharing/budgeting for L+/L- and C/Q signal for the ports on the ICE3-8IOL-G65L-V1D are as follows.

ICE3-8IOL-G65L-V1D	L+/L-			C/Q		
	Output Current Capacity (max.)	Overload Cutoff Current	Short-Circuit Protection	Output Current Capacity (max.)	Overload Cutoff Current	Short-Circuit Protection
Port 1: Independent over-current limiter circuits/IC for L+/L- and C/Q pins	1.6A	1.65A	Yes	200mA	400mA	Yes
Port 3: Independent over-current limiter circuits/IC for L+/L- and C/Q pins	1A	1.05A	Yes	200mA	400mA	Yes

ICE3-8IOL-G65L-V1D	L+/L-			C/Q		
Port	Output Current Capacity (max.)	Overload Cutoff Current	Short-Circuit Protection	Output Current Capacity (max.)	Overload Cutoff Current	Short-Circuit Protection
Ports 2 and 4 (Pair) Ports 5 and 7 (Pair) Ports 6 and 8 (Pair) There's one independent over-current limiter that protects L+/L- pins on each pair of ports, for example: Port 2 and 4. This allows you to do power budgeting on pair of ports that allows flexibility in the application. The combined overload cutoff current on a pair of ports is 1.05A for the L+/L- pins. As long as the cutoff current of 1.05A is not exceeded, the current output could be budgeted between a pair of ports such as, Port 2 and 4 any way you want. For example, Port 2 output can be at 900mA and Port 4 output can be at 100mA. Or, Port 2 could be left open and Port 4 output can be at 1A.	500mA/ port pair (1A output power budget per port pair)	1.05A/port pair	Yes	200mA*/ port	400mA*/ port	Yes
* Each port's C/Q pin has its own independent over-current limiter circuit and are not combined. The current output of C/Q pin for each port is also independently controlled and cannot be budgeted with other ports.						

Use the following procedure to attach IO-Link or digital input/output devices to the ports.

- Securely attach the IO-link cable between the IO-Link or digital input/output device and the IO-Link port.
Note: Make sure that you tighten the cables properly to maintain IP67 integrity.
- If necessary, securely attach a connector cap to prevent dust or liquids from getting into any unused ports.
Note: IO-Link ports must have an approved cable or protective cover attached to the port to guarantee IP67 compliance.
- If necessary, configure IO-Link port parameters using the **Configuration | IO-Link Settings** page to configure the port mode.
 - If an IO-Link device is attached to the port, the IO-Link LED should now be lit green and the device is receiving power.
 - If a digital input or output device is attached to the IO-Link port, after the port is configured for digital input or output on the **IO-Link Settings** page, the IO-Link LED does not light but when an event occurs:
 - Digital input causes the DI LED to flash.
 - Digital output causes the IO-Link LED to flash.

You can refer to *Configuring IO-Link Ports* on Page 44 for configuration information.

5.3. ICE3-8IOL1-G65L-V1D IO-Link Ports

The ICE3-8IOL1-G65L-V1D provides eight IO-Link ports with M12, 5-pin female/A coded connectors. Each port has robust over-current protection and short circuit protection on its L+/L- power output and C/Q IO-Link signal. The pin-out for each IO-Link port is per the IO-Link standard and is provided in the following table:

This table provides signal information for the IO-Link connectors.

	Pin	Signal	Description
IO-Link	1	L+	IO-Link device power supply (+24V)
	2	DIO	Digital input/output and diagnostics
	3	L-	IO-Link device power supply (0V)
	4	C/Q	Communication signal, which supports SDCI (IO-Link) or SIO (standard input/output) digital I/O
	5	NC	Not connected
IO-Link Class B	1	L+	IO-Link device power supply (+24V)
	2	2L+ (or UA+)	IO-Link device Actuator power supply (+24V)
	3	L-	IO-Link device power supply (0V)
	4	C/Q	Communication signal, which supports SDCI (IO-Link) or SIO (standard input/output) digital I/O
	5	2L- (or UA-)	IO-Link device Actuator power supply (0V)

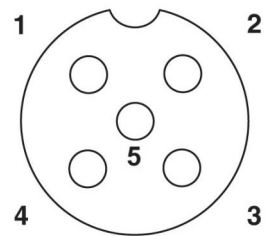

The standard SDCI (IO-Link) transmission rates are supported:

- COM1 at 4.8Kbps
- COM2 at 38.4Kbps
- COM3 at 230.4Kbps

There are active over-current limiter electronics for each port in the ICE3-8IOL1-G65L-V1D that detects the overload/short-circuit condition within a few milliseconds and shuts off the output power to protect the port and the devices connected to it. The port's power output self-recovers and restores to normal immediately after the overload or short-circuit condition is removed.

The over-current limiter circuit for L+/L- pins is separate circuits than the over-current limiter circuit for the C/Q output pin. When a port is affected by overload/short-circuit condition, it does not affect the operation of the other ports. All other ports will continue to operate normally without any glitch or interruption. The current output capacity, cutoff current, and power sharing/budgeting for L+/L- and C/Q signal for the ports on the ICE3-8IOL1-G65L-V1D are as follows.

ICE3-8IOL1-G65L-V1D		Port X1 (Class B): Output Current	Ports X2-X4 (Class B): Output Current	Ports X5-X8 (Class A): Output Current.
2L+/2L- (24VU _A / GND U _A)	Output Current Capacity (max.)	3.5A†	2.3A†	N/A
	Overload Cutoff Protection	Yes	Yes	N/A
	Short-Circuit Protection	Yes	Yes	N/A
L+/L- (24V U _S / GND U _S)	Output Current Capacity (max.)	500mA†	500mA†	500mA†
	Overload Cutoff Protection	Yes	Yes	Yes
	Short-Circuit Protection	Yes	Yes	Yes
C/Q (IO-Link mode, Digital Output mode)	Output Current Capacity (max.)	200mA*	200mA*	200mA*
	Overload Cutoff Protection	Yes	Yes	Yes
	Short-Circuit Protection	Yes	Yes	Yes
† Each port's 2L+ and L+ pins have their own independent over-current limiter circuit. The current output for each port is also independently controlled and cannot be budgeted with other ports. * Each port's C/Q pin has its own independent over-current limiter circuit. The current output of C/Q pin for each port is also independently controlled.				

Use the following procedure to attach IO-Link or digital input/output devices to the ports.

- Securely attach the IO-link cable between the IO-Link or digital input/output device and the IO-Link port.
Note: Make sure that you tighten the cables properly to maintain IP67 integrity.
- If necessary, securely attach a connector cap to prevent dust or liquids from getting into any unused ports.
Note: IO-Link ports must have an approved cable or protective cover attached to the port to guarantee IP67 compliance.
- If necessary, configure IO-Link port parameters using the **Configuration | IO-Link Settings** page to configure the port mode.
 - If an IO-Link device is attached to the port, the IO-Link LED should now be lit green and the device is receiving power.
 - If a digital input or output device is attached to the IO-Link port, after the port is configured for digital input or output on the **IO-Link Settings** page, the IO-Link LED does not light but when an event occurs:
 - Digital input causes the DI LED to flash.
 - Digital output causes the IO-Link LED to flash.

You can refer to *Configuring IO-Link Ports* on Page 44 for configuration information.

5.4. ICE3-8IOL-K45P-RJ45 IO-Link Ports

The following provides information about the IO-Link ports.

Label	Signal	Description	Value
1	L+	Power Supply Output (+)	200mA @ 24V (Maximum)
2	L-	Power Supply Output (-)	
3	DI	Digital Input	Not applicable
4	C/Q	Communication signal, which supports SDCI (IO-Link) or SIO (standard input/output) digital I/O	200mA @ 24V (Maximum)



The standard SDCI (IO-Link) transmission rates are supported:

- COM1 at 4.8Kbps
- COM2 at 38.4Kbps
- COM3 at 230.4Kbps

The ICE3-8IOL-K45P-RJ45 provides removable, pluggable terminals to connect your IO-Link devices.

The connectors on the ICE3-8IOL-K45P-RJ45 IO-Link ports are keyed headers that prevent inserting the power plug in an IO-Link port. If you want to key IO-Link ports, contact your Pepperl+Fuchs Sales Representative to purchase a key kit.

Note: A small percentage of IO-Link devices may fail to establish IO-Link communications with the ICE3-8IOL-K45P-RJ45 on Ports 1 through 4. If an actuator or a digital output driven device is connected to these ports, they may inadvertently get driven during the first 5-seconds at power-up of the ICE3-8IOL-K45P-RJ45. At power up for the first 5-seconds, Pin 4 of Ports 1 – 4 outputs 250µS long pulses once every 25ms. After the first 5-seconds, the output operates normally.

The following are the recommendations to resolve this issue:

- Do not connect an actuator to Pin 4 of Ports 1 – 4.
- Use Ports 5 – 8 to connect an actuator or a digital output device.
- If an IO-Link device does not establish communications on Ports 1 – 4, please move them to Port 5 – 8.

Use the following procedure to attach IO-Link or digital input/output devices to the ports.

1. Optionally, use a small screw driver to remove the IO-Link plug from the receptacle. By default, the IO-Link ports are keyed headers on Pins 2 and 3 of the receptacle.

Note: Do not remove the red coding sections from the headers on the IO-Link receptacle or the fully keyed power connector could be inserted in an IO-Link receptacle.

2. Optionally, key the port plug using the following information.
 - a. Locate the top of the Coding Profile Star, which is the side that has the mold markings.
 - b. Slide the Coding Profile tab (mold marking facing out) into one the end slots.
 - c. Slightly twist the star so that it snaps off the star.

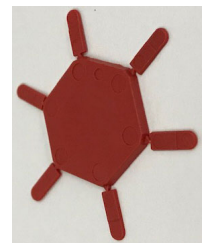

- d. Then repeat for the slot on the opposite end.



Note: This image shows that both the first position and last positions have been keyed.

3. Depress the orange tab until it is flush with the connector to insert the IO-Link device negative wire into the **L-** contact.
4. Depress the orange tab until it is flush with the connector to insert the IO-Link device positive wire into the **L+** contact.
5. If applicable, depress the orange tab until it is flush with the connector to insert the DI wire into the **DI** contact.
6. Depress the orange tab until it is flush with the connector to insert the IO-Link wire into the **C/Q** contact.
 - If an IO-Link device is attached to the port, the IO-Link LED should now be lit green and the device is receiving power.
 - If a digital input or output device is attached to the IO-Link port, after the port is configured for digital input or output on the **IO-Link Settings** page, the IO-Link LED does not light but when an event occurs:
 - Digital input causes the DI LED to flash.
 - Digital output causes the IO-Link LED to flash.
7. If necessary, configure IO-Link parameters for each port.
You can refer to *Configuring IO-Link Ports* on Page 44 for configuration information.

5.5. ICE3-8IOL-K45S-RJ45 IO-Link Ports

The following provides information about the IO-Link ports.

Label	Signal	Description	Value
1	L+	Power Supply Output (+)	200mA @ 24V (Maximum)
2	L-	Power Supply Output (-)	
3	DI	Digital Input	Not applicable.
4	C/Q	Communication signal, which supports SDCl (IO-Link) or SIO (standard input/output) digital /IO	200mA @ 24V (Maximum)

The standard SDCl (IO-Link) transmission rates are supported:

- COM1 at 4.8Kbps
- COM2 at 38.4Kbps
- COM3 at 230.4Kbps

The ICE3-8IOL-K45S-RJ45 provides removable terminal blocks to connect your IO-Link devices.

The connectors on the ICE3-8IOL-K45S-RJ45 IO-Link ports are keyed headers that prevent inserting the power connector in an IO-Link port. If you want to key IO-Link ports, contact your Pepperl+Fuchs Sales Representative to purchase a key kit.

Note: A small percentage of IO-Link devices may fail to establish IO-Link communications with the ICE3-8IOL-K45S-RJ45 on Ports 1 through 4. If an actuator or a digital output driven device is connected to these ports, they may inadvertently get driven during the first 5-seconds at power-up of the ICE3-8IOL-K45S-RJ45. At power up for the first 5-seconds, Pin 4 of Ports 1 – 4 outputs 250µS long pulses once every 25ms. After the first 5-seconds, the output operates normally.

The following are the recommendations to resolve this issue:

- Do not connect an actuator to Pin 4 of Ports 1 – 4.
- Use Ports 5 – 8 to connect an actuator or a digital output device.
- If an IO-Link device does not establish communications on Ports 1 – 4, please move them to Port 5 – 8.

Use the following procedure to attach IO-Link or digital input/output devices to the ports.

1. Optionally, use a small screw driver to remove the IO-Link plug from the receptacle.

By default, the IO-Link ports are keyed headers on Pins 2 and 3 of the receptacle.

Note: Do not remove the red coding sections from the headers on the IO-Link receptacle or the fully keyed power plug could be inserted in an IO-Link receptacle.



2. Optionally, key the plug using the following information.

- a. Locate the top of the Coding Profile Star, which is the side that has the mold markings.
- b. Slide the Coding Profile tab (mold markings facing out) into one of the end slots.
- c. Slightly twist the star so that it snaps off the star.
- d. Repeat for the slot on the opposite side.

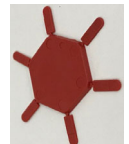

Note: This image shows that both the first position and last positions have been keyed.

3. Insert the IO-Link device negative wire into the **L-** contact and tighten the wire-clamp screws to prevent the wire from coming loose.
4. Insert the IO-Link device positive wire into the **L+** contact and tighten the wire-clamp screws to prevent the wire from coming loose.
5. If applicable, insert the DI wire into the **DI** contact and tighten the wire-clamp screws to prevent the wire from coming loose.
6. Insert the IO-Link wire into the **C/Q** contact and tighten the wire-clamp screws to prevent the wire from coming loose.
 - If an IO-Link device is attached to the port, the IO-Link LED should now be lit green and the device is receiving power.
 - If a digital input or output device is attached to the IO-Link port, after the port is configured for digital input or output on the **IO-Link Settings** page, the IO-Link LED does not light but when an event occurs:
 - Digital input causes the DI LED to flash.
 - Digital output causes the IO-Link LED to flash.
7. If necessary, configure IO-Link parameters for each port.

You can refer to *Configuring IO-Link Ports* on Page 44 for configuration information.

6. IO-Link Port Configuration

This chapter discusses port configuration, which includes these topics:

- *Preparing for Port Configuration* on Page 81
- *IO-Link Configuration Page* on Page 84
- *PROFINET IO Settings Configuration Page* on Page 89
- *Modbus/TCP Settings Configuration Page* on Page 90
- *OPC UA Settings Configuration Page* on Page 96 (not supported on all models, contact your Pepperl+Fuchs representative for more information)
- *MQTT Settings Configuration Page* on Page 99 (not supported on all models, contact your Pepperl+Fuchs representative for more information)

Although you can make configuration changes using the web interface, PROFINET IO configuration parameters overwrite the values on the following **Configuration** pages:

- *IO-Link Settings*
- *PROFINET IO Settings*
- *Network Settings*

6.1. Preparing for Port Configuration

Before beginning port configuration, you may want to verify that the connected device is functioning.

1. If necessary, log into the IO-Link master.
2. Click **Diagnostics** | **IO-Link Diagnostics**.
3. Review the **Port Status** and **IO-Link State**.

Port Status	Operational, PDI Valid	An IO-Link device is operating on the port that has received valid PDI data.
	Operational	An IO-Link device is operating on the port that has not received valid PDI data.
	Inactive	One of the following conditions exists: <ul style="list-style-type: none"> • A valid IO-Link device is not connected to the port. • A digital input or output device is connected to the port but the configured Port Mode is not correct.

IO-Link State	Operate	Port is functioning correctly in IO-Link mode but has not received valid PDI data. This may also display during a data storage upload or download.
	Init	The port is attempting initialization.
	Reset	One of the following conditions exists: <ul style="list-style-type: none"> The Port Mode configuration is set to Reset. The Port Mode configuration is set to DigitalIn or DigitalOut.
	DS: Wrong Sensor	Hardware failure (IO-Link LED also flashes red) because there is Data Storage on this port, which does not reflect the attached device.
	DV: Wrong Sensor	Hardware failure (IO-Link LED also flashes red) because Device Validation is configured for this port and the wrong device is attached.
	DS: Wrong Size	Hardware failure (IO-Link LED also flashes red) because the size of the configuration on the device does not match the size of the configuration stored on the port.
	Comm Lost	Temporary state after a device is disconnected and before the port is re-initialized.
	Pre-operate	Temporary status displayed when the device: <ul style="list-style-type: none"> Is starting up after connection or power-up. Uploading or downloading automatic data storage.

Note: If a digital input or output device is connected to an IO-Link port, there is no valid data until the port is set to the correct **Port Mode**.

- Review the **Device IO-Link Version**.
 - If the field is blank, it is not a valid IO-Link device, which could mean that it is a digital device and the port has not been configured for digital input or digital output.
 - The field displays the Device IO-Link version.
- Optionally, review the following to see if you need to change the **Configured Minimum Cycle Time**:
 - Actual Cycle Time**
 - Device Minimum Cycle Time**
 - Configured Minimum Cycle Time**

The **Configured Minimum Cycle Time** is the minimum cycle time that the IO-Link master allows the port to operate at. The **Actual Cycle Time** is negotiated between the IO-Link master and the device and will be at least as long as the greater of the **Configured Minimum Cycle Time** and the **Device Minimum Cycle Time**.

- Verify that the **Auxiliary Input Bit Status** field displays **On**, if the device is connected to DI (Pin 2 with M12 connectors).

The screenshot shows the 'IO-Link Diagnostics' page with a table of port status and device information. The table has columns for 'PORT 1' and 'PORT 4'. The 'Port Status' and 'IOLink State' rows are highlighted with a green box, indicating they are the focus of the verification step.

IO-LINK PORT STATUS	PORT 1	PORT 4
Port Name	IOLB-8108	Open
Port Mode	IOLink	IOLink
Port Status	Operational, PDI Valid	Operational, PDI Valid
IOLink State	Operate	Operate
Device Vendor Name	Pepperl+Fuchs	Pepperl+Fuchs
Device Product Name	UC400-F77-EP-IO-V31	PM180-F90-IU-IO-V15
Device Serial Number	40000069832283	40000080536299
Device Hardware Version	HW01.00	HW01.00
Device Firmware Version	FW01.00	FW01.00
Device IO-Link Version	1.1	1.1
Actual Cycle Time	4.0ms	4.0ms
Device Minimum Cycle Time	2.3ms	2.3ms
Configured Minimum Cycle Time	4ms	4ms
Data Storage Capable	Yes	Yes
Automatic Data Storage Configuration	Disabled	Disabled
Auxiliary Input Status		
Device PDI Data Length	2	2
PDI Data Valid	Yes	Yes
Last Rx PDI Data (MS Byte First)	ff fc	3d 70
PDO Lock Enable	Yes	Yes
PDO Locked	No	No
Device PDO Data Length	0	0

Note: The complete IO-Link Diagnostics is not displayed in the above example. In addition, some ports have been collapsed to simplify the view. For additional information about the IO-Link Diagnostics page, see *IO-Link Port Diagnostics* on Page 138.

6.2. IO-Link Configuration Page

You can use the **Configuration | IO-Link Settings** page to configure IO-Link port settings. When the IO-Link device is attached to a port, it begins operating without requiring any configuration. The IO-Link master and attached IO-Link device automatically negotiate the **Minimum Cycle Time**. If required by an application, you can set a specific **Minimum Cycle Time**.

This page provides special features such as Data Storage, Device Validation, and Data Validation.

Although you can make configuration changes using the web page, PROFINET IO configuration parameters overwrite the values on the **IO-Link Settings** page. See *Configuring the IO-Link master* on Page 27 for detailed configuration procedures.

This subsection discusses:

- *Editing IO-Link Port Settings* on Page 84
- *IO-Link Settings Parameters* on Page 86.

6.2.1. Editing IO-Link Port Settings

You can use this procedure to configure IO-Link settings for each IO-Link port.

If an IO-Link device is attached to the port, no configuration is required for operation. If a digital input or output device is attached, it is necessary to change the **Port Mode**.

1. If necessary, open the IO-Link master web interface with your web browser using the IP address.
2. Click **Configuration | IO-Link Settings**.
3. Click the **EDIT** button for the port or ports that you want to configure.

Note: *You can click each **EDIT** button and open all ports to quickly configure port parameters.*

4. Make appropriate selections for the device that you connected to that port.

Make sure you select the **DigitalIn** option for a digital input device and the **DigitalOut** option for a digital output device for the **Port Mode**.

The IO-Link master negotiates the **Minimum Cycle Time** so it is not necessary to set a cycle time unless you need a specific cycle time.

You can refer to *IO-Link Settings Parameters* on Page 86 if you require definitions or values for the options.

Note: *Do not enable **Automatic Download** and then attempt device configuration as **Automatic Download** changes the settings back to what is stored on the IO-Link master. **Data Storage**, **Device Validation**, and **Data Validation** are discussed in *Utilizing IO-Link master Features* on Page 121.*

5. Click the **SAVE** button for each port.

The screenshot shows the 'IO-Link Settings' configuration page. At the top, there is a navigation bar with 'PEPPERL+FUCHS' logo and menu items: Home, Diagnostics, Configuration, Advanced, Attached Devices, Support. The user is logged in as 'ICE3-BIOL-K455-RJ45'. Below the navigation bar, there are tabs for 'IO-LINK', 'PROFINET IO', 'MODBUS/TCP', 'OPC UA', 'MQTT', 'NETWORK', 'MISC', 'LOAD/SAVE', and 'CLEAR SETTINGS'. The main content area is titled 'IO-Link Settings' and contains a table for configuring 8 ports. The 'PORT 1' column is selected, and the 'SAVE' button is highlighted with a mouse cursor. The table has columns for each port (PORT 1 to PORT 8) and rows for various configuration parameters. The 'Data Storage Manual Ops' section at the bottom of the table includes 'CLEAR', 'UPLOAD', and 'DOWNLOAD' buttons for each port.

IO-LINK PORT CONFIG	PORT 1	PORT 2	PORT 3	PORT 4	PORT 5	PORT 6	PORT 7	PORT 8
	CANCEL SAVE	EDIT	EDIT	EDIT	EDIT	EDIT	EDIT	EDIT
Port Name	Triangulation	IO-Link Port 2	IO-Link Port 3	IO-Link Port 4	IO-Link Port 5	IO-Link Port 6	IO-Link Port 7	IO-Link Port 8
Port Mode	IOLink	IOLink	IOLink	IOLink	IOLink	IOLink	DigitalIn	DigitalOut
PDO Lock Enable	true	true	true	true	true	true	true	true
Invert SIO	false	false	false	false	false	false	false	false
Invert Auxiliary Input	false	false	false	false	false	false	false	false
Default SIO Digital Output State	Off	Off	Off	Off	Off	Off	Off	Off
Minimum Cycle Time (4 - 538)	4 ms	4 ms	4 ms	4 ms	4 ms	4 ms	4 ms	4 ms
Auxiliary Input Settling Time (0 - 10000)	0 ms	0 ms	0 ms	0 ms	0 ms	0 ms	0 ms	0 ms
Auxiliary Input Hold Time (0 - 10000)	0 ms	0 ms	0 ms	0 ms	0 ms	0 ms	0 ms	0 ms
SIO Input Settling Time (0 - 10000)	0 ms	0 ms	0 ms	0 ms	0 ms	0 ms	0 ms	0 ms
SIO Input Hold Time (0 - 10000)	0 ms	0 ms	0 ms	0 ms	0 ms	0 ms	0 ms	0 ms
Data Storage Config								
Storage Contents	empty	empty	empty	empty	empty	empty	empty	empty
Automatic Upload Enable	Off	Off	Off	Off	Off	Off	Off	Off
Automatic Download Enable	Off	Off	Off	Off	Off	Off	Off	Off
Data Storage Manual Ops								
	CLEAR	CLEAR	CLEAR	CLEAR	CLEAR	CLEAR	CLEAR	CLEAR
	UPLOAD			UPLOAD				
	DOWNLOAD			DOWNLOAD				

6. Return to the **IO-Link Diagnostics** page to verify that your changes have taken affect.

6.2.2. IO-Link Settings Parameters

The **Configuration | IO-Link Settings** page supports the following options.

IO-LINK Settings Page	
Port Name	User defined port or device description. <ul style="list-style-type: none"> Standard ASCII characters Max length = 80 characters
Port Mode <i>Default: IO-Link</i>	Selected IO-Link port mode. Valid settings are: <ul style="list-style-type: none"> Reset - Select to disable a port or to reset/restart an IO-Link port. IO-Link - Select to connect and operate an IO-Link device on the port. Digital In - Select if a DI device is attached to the port. Digital Out - Select if a DO device is attached to the port.
Invert SIO <i>Default: False</i>	If enabled and the Port Mode is Digital In or Digital Out , this option inverts the SIO value. <ul style="list-style-type: none"> False (Disabled - Do not invert SIO) True (Enabled - Invert SIO) <p>Note: This option does not affect the Auxiliary Input.</p>
Invert Auxiliary Input	If this option is enabled, the Auxiliary bit is inverted.
Default SIO Digital Output State <i>Default: Off</i>	If the port mode is Digital Out , defines the default digital output value that is used at startup and when there is no active PDO controller. <ul style="list-style-type: none"> Off (low voltage) - 0 On (high voltage) - 24V
Default Auxiliary Output State <i>Default: Off</i>	Available on selected models, this option defines the default auxiliary digital output value that is used at startup and when there is no active PDO controller. <ul style="list-style-type: none"> Off (high impedance) On (high voltage) - 24V
Minimum Cycle Time <i>Default: 4</i>	The minimum, or fastest, cycle time at which the IO-Link device may operate. The valid range is 4-538 ms. You can leave the Minimum Cycle Time set to the default value and the IO-Link master negotiates with the IO-Link device for its minimum cycle time. The IO-Link Diagnostics page displays the Actual Cycle Time , which is the negotiated cycle time.
Auxiliary Input Settling Time (0 - 10000)	The auxiliary input settling time that remains constant before that input is considered/accepted
Auxiliary Input Hold Time (0 - 10000)	Minimum time (msec) that the output is high.
SIO Input Settling Time (0 - 10000)	The SIO input settling time that remains constant before that input is considered/accepted.
SIO Input Hold Time (0 - 10000)	Minimum time (msec) that the output is high.

IO-LINK Settings Page (Continued)	
Data Storage Config	
Storage Contents	Indicates that the data storage for the port is empty or displays the Vendor ID and Product ID of the data stored on that port.
Automatic Data Storage Upload Enable <i>Default: Off</i>	<p>When this option is initially set to On, the IO-Link master saves the data storage parameters (if the data storage is empty) from the IO-Link device to the IO-Link master.</p> <p>Automatic upload occurs when the Automatic Upload Enable option is set to On and one of these conditions exists:</p> <ul style="list-style-type: none"> • There is no upload data stored on the gateway and the IO-Link device is connected to the port. • The IO-Link device has the DS_upload bit on (generally because you have changed the configuration via Teach buttons or web page). <p>When a port contains data storage for an IO-Link device and if you attach a device whose Vendor and Device ID do not match, the IO-Link LED on the IO-Link master flashes red to indicate a wrong device is attached. In addition, the IO-Link Diagnostics page displays DS: Wrong Sensor in the IOLink State field.</p> <p>Note: <i>Not all device parameters are sent to data storage, this is determined by the IO-Link device manufacturer.</i></p>
Automatic Data Storage Download Enable <i>Default: Off</i>	<p>The data storage parameters on the IO-Link master are downloaded to the connected IO-Link device if:</p> <ol style="list-style-type: none"> 1. The Automatic Download option is enabled. 2. The data stored on the IO-Link master port contains the same Vendor ID and Product ID as the IO-Link device connected to the port. 3. Data storage parameters are also downloaded to the IO-Link device if configuration changes are made on the device causing the DS_upload bit to turn on and automatic upload is not enabled. 4. The IO-Link device requests an upload and the Automatic Upload Enable option is set to Off. <p>If you change configuration parameters on the IO-Link device and want the parameters to remain loaded on the IO-Link device, you must disable the Automatic Download option. If you do not disable Automatic Download, the IO-Link master will reload the data storage on the port to the IO-Link device.</p>
Data Storage Manual Ops	<p>The Manual Data Storage Ops option provides the following functionality, if data storage is supported by the IO-Link device.</p> <ul style="list-style-type: none"> • CLEAR - this clears any stored data for an IO-Link device on this port. • UPLOAD - this uploads and stores the IO-Link device configuration on the IO-Link master. • DOWNLOAD - this downloads the stored IO-Link device configuration from the IO-Link master to the IO-Link device attached to this port if the Vendor ID and Device ID match.

IO-LINK Settings Page (Continued)	
Validation Config	
Device Validation Mode (Default: None)	<p>Device Validation Mode provides these options:</p> <ul style="list-style-type: none"> • None - this disables Device Validation Mode. • Compatible - permits a compatible IO-Link device (same Vendor ID and Device ID) to function on the corresponding port. • Identical - only permits an IO-Link device to function on the corresponding port as defined in the following fields. <ul style="list-style-type: none"> - Vendor ID - Device ID - Serial Number <p>Note: <i>Connecting an IO-Link device that is different than the configured with Data Validation enabled will generate a DV: wrong sensor error.</i></p>
Vendor Id (0-65535)	<p>This is required if you select a Device Validation Mode other than <i>None</i>.</p> <p>The Vendor ID can be manually entered in this field or click the GET ATTACHED button and the IO-Link master populates the Vendor ID in this field.</p>
Device Id (0-16777215)	<p>This is required if you select a Device Validation Mode other than <i>None</i>.</p> <p>The Device ID can be manually entered in this field or click the GET ATTACHED button and the IO-Link master populates the Device ID in this field.</p>
Serial Num	<p>This is required if you select Identical for the Device Validation Mode.</p> <p>The Serial Number can be manually entered in this field or click the GET ATTACHED button and the IO-Link master populates the serial number in this field.</p>
Data Validation Mode (Default: None)	<p>There are three Data Validation Modes:</p> <ul style="list-style-type: none"> • None - no data validation is performed on the port. • Loose - the slave device's PDI/PDO lengths must be less than or equal to the user-configured values. • Strict - the slave device's PDI/PDO lengths must be the same as the user-configured values.
PDI Length (0-32)	<p>This is input length of the PDI data field.</p> <p>This is required if you select a Data Validation Mode other than <i>None</i>.</p> <p>The PDI Length can be manually entered in this field or click the GET ATTACHED button and the IO-Link master populates the PDI length in this field.</p>
PDO Length (0-32)	<p>This is input length of the PDO data field.</p> <p>This is required if you select a Data Validation Mode other than <i>None</i>.</p> <p>The PDO Length can be manually entered in this field or click the GET ATTACHED button and the IO-Link master populates the PDO length in this field.</p>
GET ATTACHED (Button)	<p>After opening a port for editing, you can click the GET ATTACHED button to automatically populate the following fields with data from the IO-Link device:</p> <ul style="list-style-type: none"> • Vendor Id • Device Id • Serial Num • PDI Length • PDO Length

2022-12

6.3. PROFINET IO Settings Configuration Page

The following table provides information about the Configuration| PROFINET IO page options.

You can refer to *Device Name Assignment* on Page 39 for PROFINET IO configuration procedures. You must have Administrator or Operator privileges to change any settings on this page.

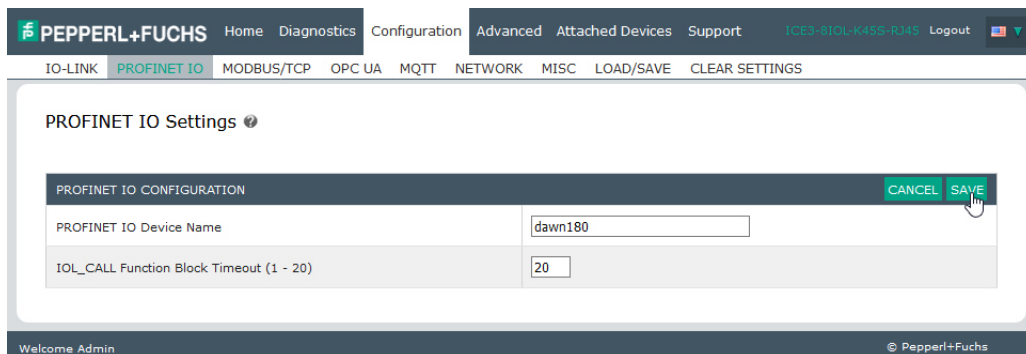

PROFINET IO Settings Page	
PROFINET IO Device Name	<p>The PROFINET IO Device Name is the same as the name later used to configure PROFINET IO for the IO-Link master.</p> <p>The device name must be specified according to DNS conventions.</p> <ul style="list-style-type: none"> • Restricted to a total of 240 characters (letters, digits, dash or period) • Parts of the name within the device name; in other words, a string between two periods, must not exceed a maximum of 63 characters. • No special characters such as umlauts (ä, ö etc.), brackets, underscore, slash, blank etc. The dash is the only permitted special character. • The device name must not begin or end with the "-" character. • The device name must not begin with numbers. • The device name must not have the structure n.n.n.n (n = 0...999). • The device name must not begin with the character string "port-xyz-" (x ,y, z = 0...9).
IOL_CALL Function Block Timeout (1-20)	<p>The IOL_CALL Function Block Timeout range is 1 - 20 and the default is 20.</p>

6.4. Modbus/TCP Settings Configuration Page

You can use the **Configuration | Modbus/TCP Settings** page to configure Modbus/TCP with the IO-Link master. Additional Modbus information is available in the following chapters:

- *Modbus/TCP Functionality Descriptions on Page 177*
- *Modbus/TCP Functionality Descriptions on Page 177*

This subsection includes these topics:

- *Editing Modbus/TCP Settings on Page 90*
- *Modbus/TCP Settings Parameters on Page 92*

The screenshot displays the 'Modbus/TCP Settings' configuration page. At the top, there is a navigation bar with 'PEPPERL+FUCHS' and various menu items like 'Home', 'Diagnostics', 'Configuration', 'Advanced', 'Attached Devices', and 'Support'. Below this is a sub-navigation bar with 'IO-LINK', 'PROFINET IO', 'MODBUS/TCP', 'OPC UA', 'MQTT', 'NETWORK', 'MISC', 'LOAD/SAVE', and 'CLEAR SETTINGS'. The main content area is titled 'Modbus/TCP Settings' and contains a table with columns for 'MODBUS/TCP PORT CONFIG' and 'PORT 1' through 'PORT 8'. Each port column has an 'EDIT' button. The table is divided into sections: 'ISDU Data Settings' (ISDU Response Timeout), 'Process Data Settings' (PDI Data Block Size, PDI Byte-Swap Method, PDO Data Block Size, PDO Byte-Swap Method, Append PDO to PDI Data, Clear Event Code In PDO Block, Clear Event Code After Hold Time, Active Event Hold Time, Event Hold Time Units, Clear Event Hold Time, Event Clear Time Units), 'Transfer Mode Settings' (Slave Mode Device ID, PDI Receive Mode(s), PDO Transmit Mode(s)), and 'Modbus Master PLC Settings' (PLC ID Address). At the bottom of the table, there is a 'MODBUS/TCP CONFIGURATION' section with a 'Modbus Enable' dropdown menu set to 'enable'. There are 'CANCEL' and 'SAVE' buttons at the bottom right of the table area. The footer of the page shows 'Welcome Admin' and '© Pepperl+Fuchs'.

Note: Modbus is disabled by default. To use Modbus, click the **EDIT** button and select **Enable**.

6.4.1. Editing Modbus/TCP Settings

1. If necessary, open the IO-Link master web interface with your web browser using the IP address.
2. Click **Configuration | Modbus/TCP**.
3. Click the **EDIT** button for the port that you want to configure.

2022-12

Note: You can click each **EDIT** button and open all ports to quickly configure port parameters.

4. Make appropriate selections for the IO-Link device that you will connect to that port. You can refer to *Modbus/TCP Settings Parameters* on Page 92 if you require definitions or values for the options.
5. Scroll to the top of the page and click the **SAVE** button.

Make sure that the port now displays the **EDIT** button.

If it displays the **SAVE** and **CANCEL** buttons, that means that one of the parameters contains an incorrect value. If necessary, scroll down the page, make the needed corrections, and click **SAVE**.

Modbus/TCP Settings

MODBUS/TCP PORT CONFIG	PORT 1	PORT 2	PORT 3	PORT 4	PORT 5	PORT 6	PORT 7	PORT 8
	CANCEL SAVE	EDIT	EDIT	EDIT	EDIT	EDIT	EDIT	EDIT
ISDU Data Settings:								
ISDU Response Timeout (1 - 10000)	100000 sec Maximum 10000	20 sec	20 sec	20 sec	20 sec	20 sec	20 sec	20 sec
Process Data Settings:								
PDI Data Block Size (To PLC)	36 bytes	36 bytes	36 bytes	36 bytes	36 bytes	36 bytes	36 bytes	36 bytes
PDI Byte-Swap Method	no byte-swap	no byte-swap	no byte-swap	no byte-swap	no byte-swap	no byte-swap	no byte-swap	no byte-swap
PDO Data Block Size (From PLC)	32-bytes	32-bytes	32-bytes	32-bytes	32-bytes	32-bytes	32-bytes	32-bytes
PDO Byte-Swap Method	no byte-swap	no byte-swap	no byte-swap	no byte-swap	no byte-swap	no byte-swap	no byte-swap	no byte-swap
Append PDO to PDI Data	false	false	false	false	false	false	false	false
Clear Event Code In PDO Block	false	false	false	false	false	false	false	false
Clear Event Code After Hold Time	true	true	true	true	true	true	true	true
Active Event Hold Time (1 - 65535)	1000	1000	1000	1000	1000	1000	1000	1000
Event Hold Time Units	ms	ms	ms	ms	ms	ms	ms	ms
Clear Event Hold Time (1 - 65535)	500	500	500	500	500	500	500	500
Event Clear Time Units	ms	ms	ms	ms	ms	ms	ms	ms
Transfer Mode Settings:								
Slave Mode Device ID (1 - 247)	1	1	1	1	1	1	1	1
MODBUS/TCP CONFIGURATION	EDIT							
Modbus Enable	enable							

Welcome Admin © Pepperl+Fuchs

6.4.2. Modbus/TCP Settings Parameters

The following table provides detailed information about the **Modbus/TCP Settings** page.

Modbus/TCP Settings Page	
<i>Process Data Settings</i>	
PDI Data Block Size (To PLC) <i>Default: 36-bytes</i>	The configurable PDI data block length. Optional lengths are: <ul style="list-style-type: none"> • 4-bytes (header only) • 8-bytes (4 bytes data) • 16-bytes (12 bytes data) • 24-bytes (20 bytes data) • 36-bytes (32 bytes data)
PDI Byte-Swap Method <i>Default: No byte-swap</i>	If enabled, the IO-Link master swaps the data bytes in word (2 byte) format or dword (4 byte) format. Options include: <ul style="list-style-type: none"> • No byte-swap – data passed through as received • Word (16-bit) byte-swap – data is byte-swapped in word format • Dword (32-bit) byte-swap – data is byte-swapped in dword format • Reverse registers – data passed through after being reversed <p><i>Note: Because both IO-Link and Modbus/TCP use big-endian byte ordering, byte swapping typically is not required for word and dword data.</i></p> <p><i>Byte swapping is most commonly required when receiving byte (8-bit) data and it is desired to place the first data byte in the least significant byte position of the holding register. For these cases, word (16 bit) byte-swap is typically used.</i></p>
PDO Data Block Size (From PLC) <i>Default: 32-bytes</i>	The configurable PDO data block length. Optional lengths are: Event code not included: <ul style="list-style-type: none"> • 4-bytes = 2 data words • 8-bytes = 4 data words • 16-bytes = 8 data words • 24-bytes = 12 data words • 32-bytes = 16 data words • 34-bytes = 16 data words, 1 pad word Event code included: <ul style="list-style-type: none"> • 4-bytes = event code word, 1 data word • 8-bytes = event code word, 3 data words • 16-bytes = event code word, 7 data words • 24-bytes = event code word, 11 data words • 32-bytes = event code word, 15 data words • 34-bytes = event code word, 16 data words

2022-12

Modbus/TCP Settings Page (Continued)	
PDO Byte-Swap Method <i>Default: No byte-swap</i>	<p>If enabled, the IO-Link master swaps the data bytes in word (2 byte) format or dword (4 byte) format. Options include:</p> <ul style="list-style-type: none"> • No byte-swap – data passed through as received • Word (16-bit) byte-swap – data is byte-swapped in word format • Dword (32-bit) byte-swap – data is byte-swapped in dword format • Reverse registers – data passed through after being reversed <p>Note: <i>Because both IO-Link and Modbus/TCP use big-endian byte ordering, byte swapping typically is not required for word and dword data.</i></p> <p><i>Byte swapping is most commonly required when sending byte (8-bit) data to the IO-Link device and it is desired to send the least significant byte of the holding register first. For these cases, word (16 bit) byte-swap is typically used.</i></p>
Append PDO to PDI Data <i>Default: False</i>	<p>If selected, the IO-Link master appends any PDO data to the end of the PDI data.</p> <ul style="list-style-type: none"> • False = Do not append PDO data • True (enable check box) = Append PDO data
Clear Event Code in PDO Block <i>Default: False</i>	<p>If enabled, the IO-Link master expects the first word of the PDO block to be used for event code handling.</p> <p>Values are:</p> <ul style="list-style-type: none"> • True (enable check box) = expect event code • False = no event code, expect only PDO data
Clear Event Code After Hold Time <i>Default: True</i>	<p>If enabled, the IO-Link master clears any event code reported in the PDI data block after the Event Active Hold Time.</p> <p>Values are:</p> <ul style="list-style-type: none"> • True (enable check box) = clear event code after hold time • False = do not clear event code after hold time
Active Event Hold Time <i>Default: 1000 ms</i>	<p>If Clear Event Code After Hold Time is enabled, the time period an event code is reported in the PDI block before it is cleared.</p> <p>Valid range: 1-65535</p> <p>Valid Units are:</p> <ul style="list-style-type: none"> • ms (milliseconds) • sec (seconds) • min (minutes) • hours • days



Modbus/TCP Settings Page (Continued)	
Event Hold Time Units	Valid Units: <ul style="list-style-type: none">• ms (milliseconds)• sec (seconds)• min (minutes)• hours• days
Clear Event Hold Time <i>Default: 500 ms</i>	Once an event code has been cleared, the time an event code stays cleared in the PDI block before another event code can be reported. Valid range: 1-65535 Valid Units: <ul style="list-style-type: none">• ms (milliseconds)• sec (seconds)• min (minutes)• hours• days
Event Clear Time Units	Valid Units: <ul style="list-style-type: none">• ms (milliseconds)• sec (seconds)• min (minutes)• hours• days

Modbus/TCP Settings Page (Continued)	
<i>Transfer Mode Settings</i>	
Slave Mode Device ID <i>Default: 1</i>	The Modbus Device ID used to access this IO-Link port. Range: 1-247
PDI Receive Mode(s) (To PLC) <i>Default: Slave</i>	Determines which PDI Receive (To PLC) Modes are enabled. The selectable modes are: <ul style="list-style-type: none"> • Slave • Master
PDO Transmit Mode(s) (From PLC) <i>Default: Slave</i>	Selectable Modes are: <ul style="list-style-type: none"> • Disabled • Slave • Master
<i>Modbus Master Write PDI Settings</i>	
PDI Data Address (base 1) (1-65535) (Default: 1)	The address to write the port's PDI data to on the slave device. (PDI to PLC).
PLC Max Update Rate (0-10000) (Default: 0)	How often to write PDI to the slave.
Heartbeat Update Rate (50 - 10000) (Default: 1000)	The IO-Link master updates your PLC at this rate in situations when the PDI is not changing.
<i>Modbus Master Read PDO Settings</i>	
PDO Data Address (base 1) (1-65535) (Default: 1)	The address on the slave device to read the PDO data from. (PDO from PLC).
PLC Poll Rate (40-65535) (Default: 40)	How often to read PDO from the slave.

6.5. OPC UA Settings Configuration Page

Use the **Configure | OPC UA Settings** page to configure OPC UA with the IO-Link master.

Note: All IO-Link master units are shipped from the factory with identical configurations. They all have the identical, self-signed, Pepperl+Fuchs Server RSA Certificates, Server RSA Keys, Server DH Keys, and no Client Authentication Certificates. For maximum data and access security, you should configure all IO-Link master units with custom certificates and keys.

This subsection includes these topics:

- [Edit OPC UA Settings on Page 97](#)
- [OPC UA Settings Parameters on Page 97](#)

Note: OPC UA is disabled by default.

6.5.1. Edit OPC UA Settings

You can use this procedure to edit OPC UA settings.

1. If necessary, open the IO-Link master web interface with your web browser using the IP address.
2. Click **Configuration | OPC UA**.
3. Enable each port that you want to allow OPC UA clients to write PDO data.
 - a. Click the **EDIT** button.
 - b. Set to **enable**.
 - c. Click the **SAVE** button.
4. Click the *OPC UA Configuration* **EDIT** button.
 - a. Set the OPC UA Server Enable option to **enable**.
 - b. Make the appropriate selections for your environment. You can refer to *OPC UA Settings Parameters* on Page 97 if you require definitions or values for the options.
5. Click the **SAVE** button.

6.5.2. OPC UA Settings Parameters

The following table provides information about the **OPC UA Setting** page.

OPC UA Settings Page	
OPC UA Port CONFIG	
Allow OPC UA clients to write PDO data (Default = disable)	Determines whether OPC UA clients are allowed to write PDO data to the IO-Link devices.
OPC UA CONFIGURATION	
OPC UA Server Enable (Default = disable)	This option controls whether or not the OPC UA server runs on the IO-Link master.
Work-around for faulty OPC UA clients that require unique browsenames (Default = disable)	Enables an alternative set of browsenames where each node's browsename is unique. Normally only browsepaths are required to be unique.
Show only currently selected process data groups	Some IO-Link devices have multiple possible layouts for PDI/PDO data, and the user selects the active layout when configuring the IO-Link device. If this option is set to "enable", then only the currently active PDI/PDO layout will be present in the OPC UA object tree. If this option is "disable" (the default) the the OPC UA object tree will contain all possible PDI/PDO layouts, and the OPC UA client must select the correct one.
Allow OPC UA clients to write ISDU data (Default = disable)	Determines whether OPC UA clients are allowed to write ISDU data to the IO-Link devices.
ApplicationName	The application name string to be presented by OPC UA server to the clients.
ApplicationURL	The application URI string to be presented by OPC UA server to the clients.

OPC UA Settings Page (Continued)	
Username	If this configuration field is non-empty, then clients who attempt to establish a connection will be required to authenticate themselves with the configured username and password.
Password	If this configuration field is non-empty, then clients who attempt to establish a connection will be required to authenticate themselves with the configured username and password.
Server Certificate Source	<p>Determines the server certificate to be used by the OPC UA server. The choices are:</p> <ul style="list-style-type: none"> • None will cause encryption support to be disabled, and no certificate will be presented to clients. • Default Web Server Certificate uses the same automatically generated, self-signed certificate that is used by the web server. • Custom Certificate Below uses the user-supplied certificate and the associated private key. <ul style="list-style-type: none"> - If configured with a CA certificate, the IO-Link master requires all SSL/TLS clients to present an RSA identity certificate that has been signed by the configured CA certificate. As shipped, the IO-Link master is not configured with a CA certificate and all SSL/TLS clients are allowed. <p>This uploaded CA certificate that is used to validate a client's identity is sometimes referred to as a <i>trusted root certificate</i>, a <i>trusted authority certificate</i>, or a <i>trusted CA certificate</i>. This CA certificate might be that of a trusted commercial certificate authority or it may be a privately generated certificate that an organization creates internally to provide a mechanism to control access to resources that are protected by the SSL/TLS protocols.</p> <p>This section does not discuss the creation of CA Certificates.</p> <ul style="list-style-type: none"> - DH key pair is a private/public key that is used by some cipher suites to encrypt the SSL/TLS handshaking messages. <p>Possession of the private portion of the key pair allows an eavesdropper to decrypt traffic on SSL/TLS connections that use DH encryption during handshaking.</p> <p>The DH (Diffie-Hellman) key exchange, also called exponential key exchange, is a method of digital encryption that uses numbers raised to specific powers to produce decryption keys on the basis of components that are never directly transmitted, making the task of a would-be code breaker mathematically overwhelming.</p> <p>The most serious limitation of Diffie-Hellman (DH key) in its basic or pure form is the lack of authentication. Communications using Diffie-Hellman all by itself are vulnerable to man in the middle attacks. Ideally, Diffie-Hellman should be used in conjunction with a recognized authentication method such as digital signatures to verify the identities of the users over the public communications medium.</p>
Server Certificate Server Private Key	If the server certificate source is set to Custom certificate below , then these two files must contain a PEM or DER encoded certificate and matching private key.

OPC UA Settings Page (Continued)	
Client Authentication Certificate #1 Client Authentication Certificate #2	If either of these is configured with a certificate, then clients attempting to establish a new connection or session will be required to present a client certificate that can be authenticated using either one of these two configured certificates.

6.6. MQTT Settings Configuration Page

All IO-Link master units are shipped from the factory with identical configurations. They all have the identical, self-signed, Pepperl+Fuchs Server RSA Certificates, Server RSA Keys, Server DH Keys, and no Client Authentication Certificates. For maximum data and access security, you should configure all IO-Link master units with custom certificates and keys.

The screenshot shows the MQTT Settings page with the following sections:

MQTT PORT CONFIG	PORT 1	PORT 2	PORT 3	PORT 4	PORT 5	PORT 6	PORT 7	PORT 8
Process Data Publish Interval Min (100 - 999999)	1000 ms	1000 ms	1000 ms	1000 ms	1000 ms	1000 ms	1000 ms	1000 ms
Process Data Publish Interval Max (0 - 999999)	0 s	0 s	0 s	0 s	0 s	0 s	0 s	0 s
PDO Write Enable	enable	disable	disable	disable	disable	disable	disable	disable

MQTT CONFIGURATION

- MQTT Client Enable: enable
- Server Name/IP: [Empty]
- Server Port (0 - 65535): 1883
- Use SSL/TLS: false
- Server Authentication Certificate: Browse... No file selected.
- Verify Server Certificate Name: false
- Client Certificate: Browse... No file selected.
- Client Private Key: Browse... No file selected.
- Username: [Empty]
- Password: [Empty]
- Client ID: [Empty]
- Request Broker Retention: false
- Publish Request QoS: at most once (qos=0)
- Subscribe Request QoS: at most once (qos=0)
- Topic Base Path: [Empty]

Note: MQTT is disabled by default.

6.6.1. MQTT Settings Page

The following table illustrates the *MQTT Port Configuration* settings.

Field0	Type	Default	Description
Process Data Publish Interval min (100 - 999999)	int	1000	Minimum interval (milliseconds) between successive PDI (or PDO) messages for the port.
Process Data Publish Interval max(100 - 999999)	int	0	Maximum interval (seconds) between successive PDI (or PDO) messages for a port (0 == infinite).
PDO Write Enable	enum	disable	Enable PDO write

The following table provides information about *MQTT Configuration* for client data that are global MQTT configuration settings.

Field	Type	Default	Description
MQTT Client Enable	enum	disable	Enable/disable the MQTT client..
Server Name/IP	string		MQTT server hostname or IPv4 address.
Server Port (0 - 65535)	int	1883	MQTT Broker port – typically 1883 for unencrypted and 8883 for TLS.
Use SSL/TLS	boolean	false	Use SSL/TLS encryption..
Server Authentication Certificate	file		The Server Authentication Certificate is used by the IO-Link master to verify the server's identity. The X509 certificate is used to verify server identity (PEM encoding). You must enable the Use SSL/TLS option for this feature to work.
Verify Server Certificate Name	boolean	false	Enable verification of information (e.g. name) in server auth certificate.
Client Certificate	file		The Client Authentication Certificate is sent by the IO-Link master (the client) to the server to verify the client's identity. The X509 certificate is sent to server for authentication (PEM encoding). You must enable the Use SSL/TLS option for this feature to work.
Client Private Key	file		The Client Private Key is required to use the Client Authentication Certificate as described above. The private key for above certificate (PEM encoding). You must enable the Use SSL/TLS option for this feature to work.
Username	string		User name sent to server for authentication.
Password	string		Password sent to server for authentication.
Client ID	string		Client ID sent to server when connecting any unique string.
Request Broker Retention	boolean	false	Request that broker retain published messages.
Publish Request QoS	enum	at most once	QoS level 0 requested when publishing.
Subscribe Request QoS	enum	at most once	QoS level 0 requested when subscribing.
Topic Base Path	string		Path prefix used for all publish messages.

2022-12

Field	Type	Default	Description
Don't Allow Illegal Characters in PDI/ PDO Field Names	boolean	true	Convert PDI/PDO field names to valid JavaScript identifiers by replacing illegal characters with underscores.
Client Status Publish Interval (0 - 999999)	int	10	Publishing interval (seconds) for the client status message (0 == disable).
ISDU Write Enable	enum	disable	Enable ISDU write.

6.6.2. Configuring MQTT

Use this procedure to configure MQTT settings.

Note: *By default, MQTT is disabled.*

1. Refer to the *MQTT Settings* table on Page 100 if you require definitions or values for the options.
2. If necessary, click **Configuration | MQTT**.
3. To configure port-level values, click the **EDIT** button below the port that you want to update.
4. Click the **SAVE** button after updating the settings.
5. Click the **MQTT Configuration EDIT** button.
6. Select **enable** from the **MQTT Client Enable** option drop box.
7. Enable other options that your environment requires.
8. Scroll to the top of the page and click the **SAVE** button.

7. Loading and Managing IODD Files

There are several **Attached Devices** pages that support IO-Link Device Description (IODD) file management.

- *IO-Link Device Description Files Page* - load IODD files from the IO-Link device manufacturer onto the IO-Link master.
- *IO-Link Device Configuration Summary Page* on Page 111 - verify the correct files were loaded for each IO-Link device or use the page to retrieve information about the baud rate, SIO mode, and device number.
- The **Port** pages are discussed in *Configuring IO-Link Devices* on Page 112.

7.1. IO-Link Device Description Files Page

Use the **IO-Link Device Description Files** page to update (upload) and delete IO-Link Device Description (IODD) files associated with this IO-Link master. In addition, you can review the IODD **xml** file by clicking the **IODD FILENAME** in the table after loading the IODD file.

Note: You will need to download the appropriate IODD files from your IO-Link device manufacturer.-

The IO-Link master provides 15790K of space to store IODD files. The IO-Link master includes the following default IODD files, which cannot be deleted.

- **IODD-StandardDefinitions1.0.1.xml**
- **IODD-StandardUnitDefinitions1.0.1.xml**
- **IODD-StandardDefinitions1.1.xml**
- **IODD-StandardUnitDefinitions1.1.xml**

Note: You can use the *Configuration | Load/Save* feature to backup your IODD files. You can save the configuration file from an IO-Link master that has IODD files installed and then load that configuration file to another IO-Link master to quickly load the IODD files.

7.1.1. Locating IODD Files Using IODD Finder

You can quickly download the IODD files using the IODD Finder option from <https://io-link.com> using the following procedure.

1. Type <https://io-link.com> and click the **IODDfinder** option.

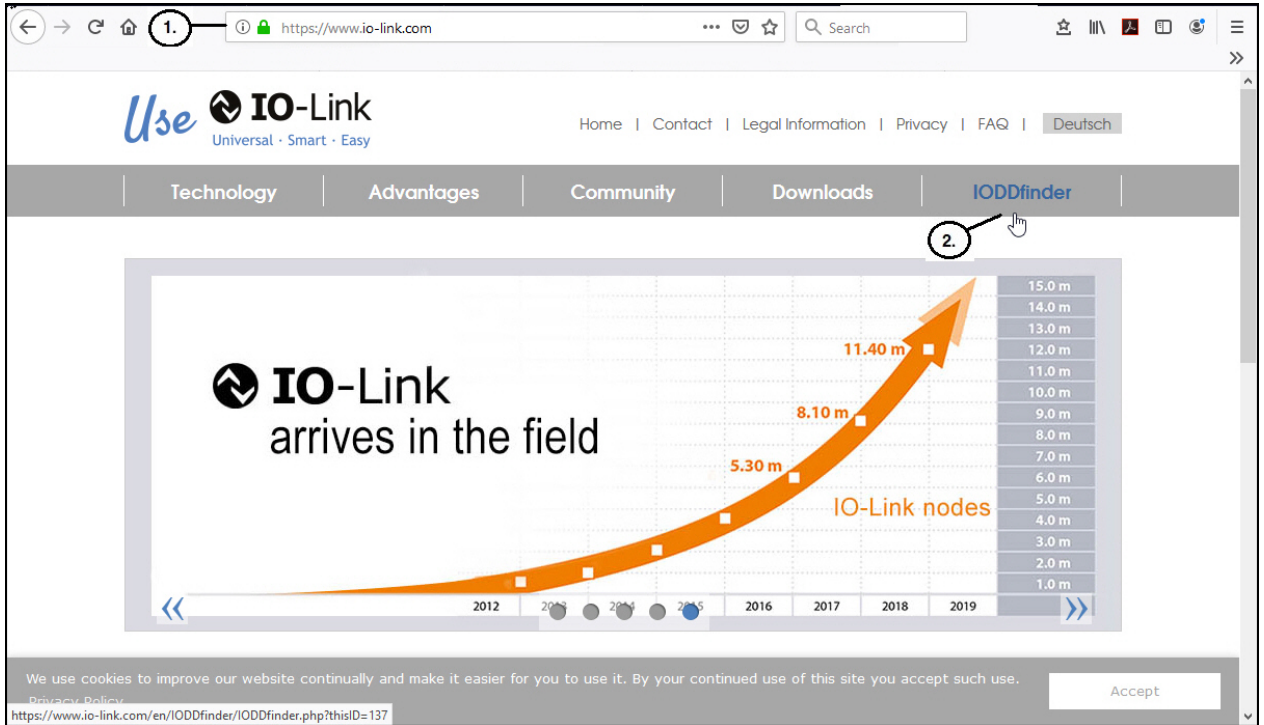

2. Click the **IODDfinder** button.

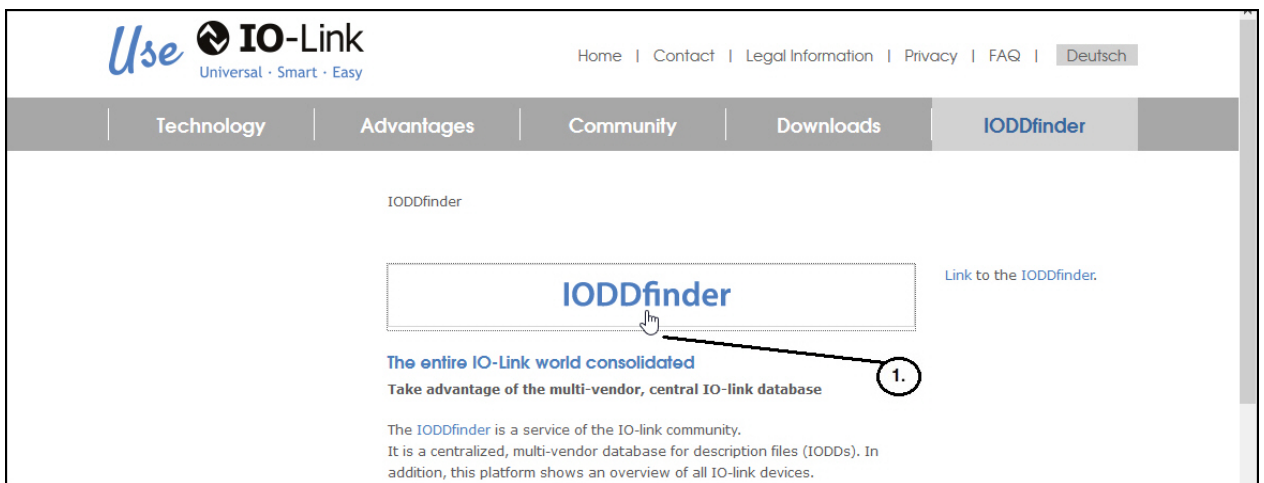

3. Begin typing the product type code and click the appropriate selection as shown below.

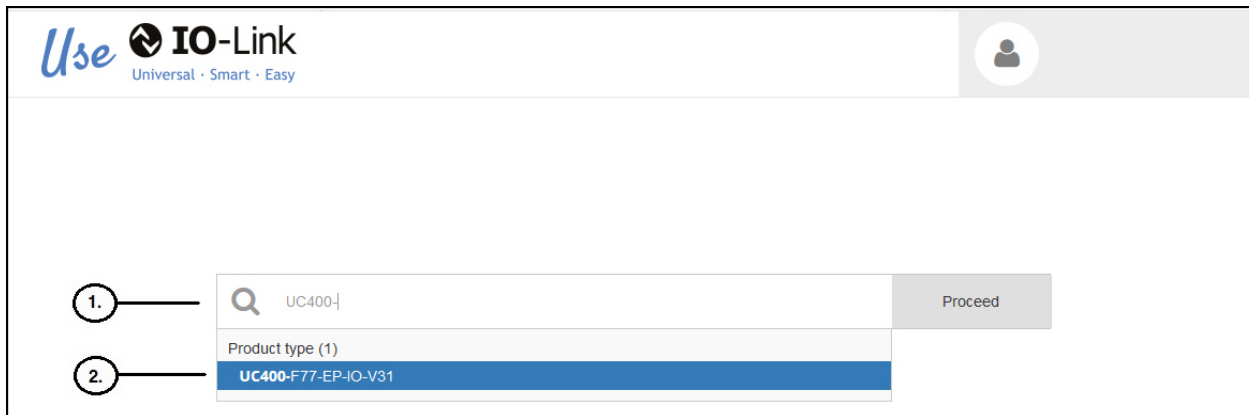

4. Select the **Download** button and save the file to your system.



7.1.2. Preparing IODD Files to Upload

After downloading the IODD files for the IO-Link device from the IO-Link sensor or actuator manufacturer, you may need to unzip the file and locate the appropriate **xml** file for the device.

- Some IODD zip files contain the **xml** files and supporting image files for a single product. This type of zip file can be immediately loaded onto the IO-Link master.
- Some IODD zip files contain the files for multiple products. If you upload this type of IODD zip file, the IO-Link master loads the first **xml** file and the associated image files, which may or may not correspond to the IO-Link device connected to the port. If you need to zip the appropriate files, the following information may be useful:
 - Unzip the package and locate the **xml** file needed for your IO-Link device.
 - Open the **xml** file and search for the **productID**, which identifies the IO-Link device.
 - Zip the **xml** file along with the supporting images. There are several ways to locate the supporting images:
 - Locate the appropriate images using the **xml** file.
 - Load only the **xml** file and the IO-Link master notifies you what files are missing. Use the **UPDATE** feature to upload the missing images.
 - Zip the **xml** with all of the images and the IO-Link master ignores (and not upload) any unused files and notifies which files did not upload.

Note: Image files are not required for IO-Link device configuration.

Use the appropriate discussion for your IODD files.

- [Uploading IODD Zip Files](#)
- [Viewing IODD Files on Page 109](#)

7.1.3. Uploading IODD Zip Files

You can use the following procedure to upload IODD zip files.

Note: You can save uploaded IODD files in a configuration file that you can use to load to other IO-Link masters or for restoration purposes. See *IO-Link master Configuration Files on Page 130* for information about configuration files.

1. Click **Attached Devices** and **IODD FILES**.
2. Click the **UPLOAD FILE** button.
3. Click the **CHOOSE FILE** button and browse to the file location.
4. Highlight the **zip** file, click **Open** and then the **UPLOAD** button.

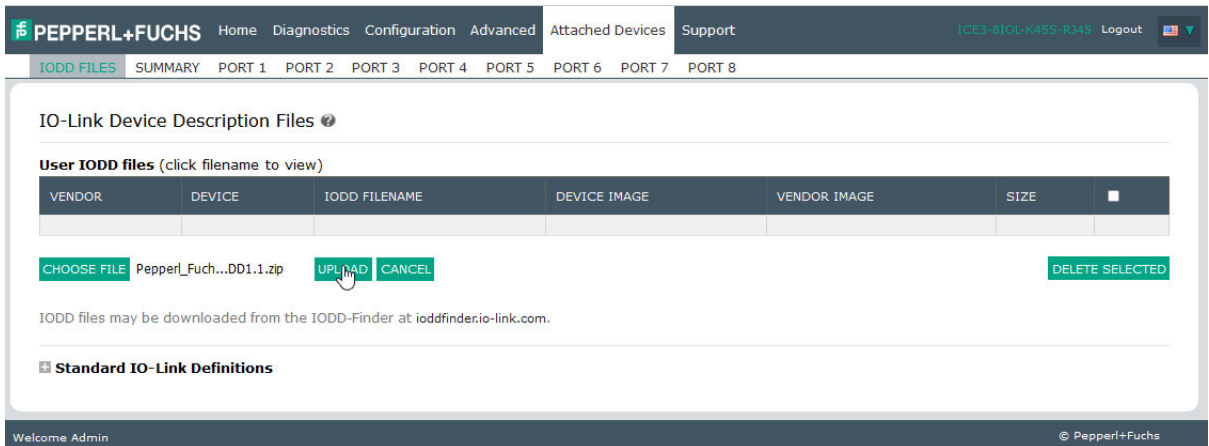

5. If necessary, click **OK**.

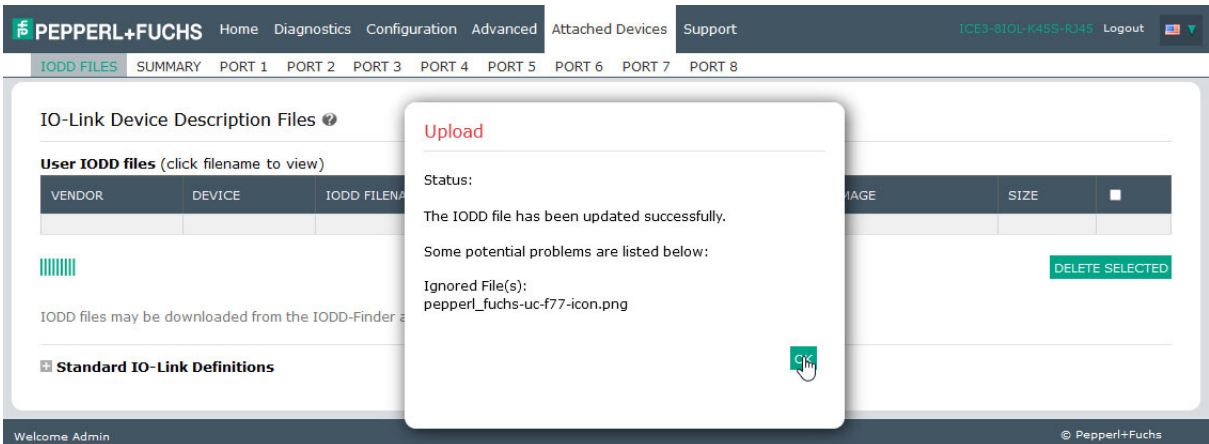

Note: Only images referenced in the xml file load to the IO-Link master and the remaining files are ignored. The IO-Link master notifies you what files are missing. The missing files do not affect the operation of the IODD Port page but the product image and logo for the IO-Link device company do not display.

If the IODD zip file contains multiple **xml** files, the IO-Link master may not load the **xml** file version that you want to use. If there are multiple xml files in the zip file, you will receive an *Overwrite* message as shown in the following example.

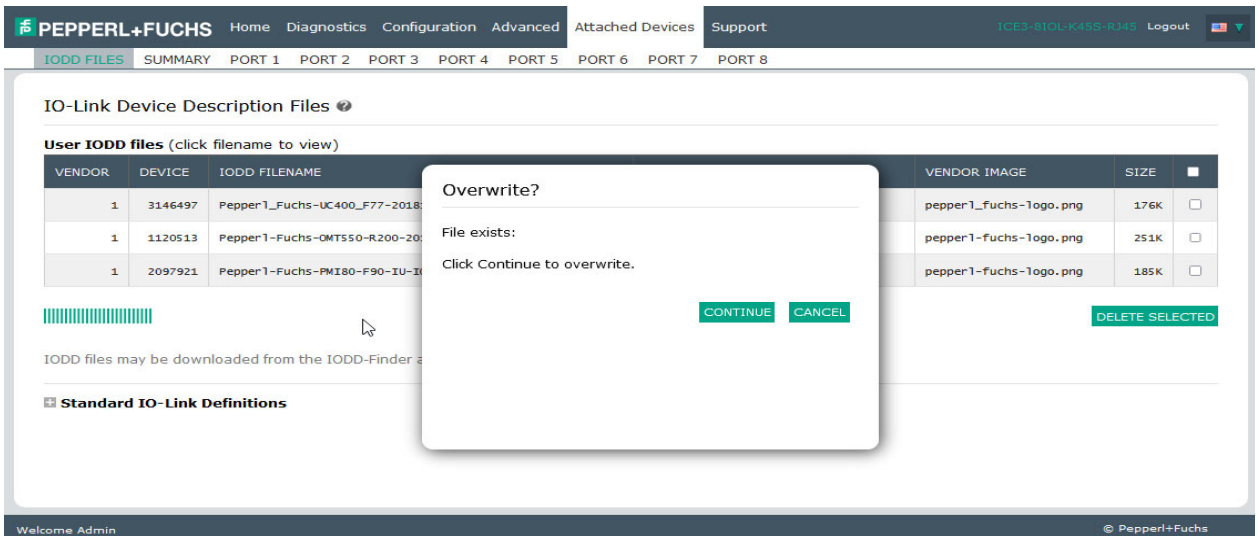

In this example, the 1.0.1 IODD files loaded but you want to use 1.1 IODD files. If that is the case, go to *Uploading Specific .XML Files or Supporting Files* on Page 107.

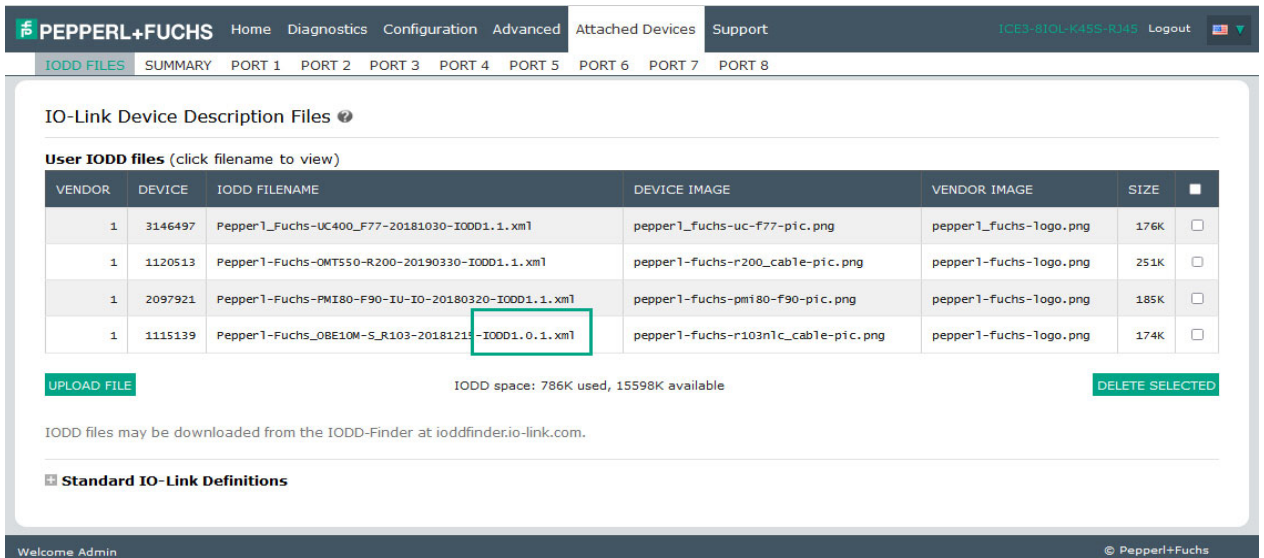

- Optionally, verify that the correct **xml** file was loaded using the **Summary** page (Page 111).

7.1.4. Uploading Specific .XML Files or Supporting Files

In the event that you need to unzip the IODD files to locate appropriate **xml** file, you can use this example where the 1.0.1 **xml** file loaded but you want to load the 1.1 **xml** file. Refer to *Preparing IODD Files to Upload* on Page 104 for more information about IODD file assemblies.

1. Unzip the IODD file assembly and locate the appropriate xml file set that you want to load. In this example, we want to load the 1.1 xml file, which is located in this subdirectory.

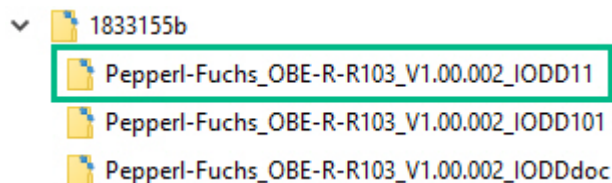

2. View the contents of the subdirectory and locate the appropriate file. Make sure that select the xml file that matches your IO-Link device.

Name	Date	Type	Size
Pepperl-Fuchs_cable_cqin_nc_4pol-con-pic.png	4/6/2016 1:07 AM	PNG File	12 KB
Pepperl-Fuchs_OBE10M-S_R103-20181215-IODD1.1.xml	10/26/2021 1:52 PM	XML Document	41 KB
Pepperl-Fuchs_OBE20M-S-L_R103-20181215-IODD1.1.xml	10/26/2021 1:52 PM	XML Document	41 KB
Pepperl-Fuchs_plug_cqin_na_3pol-con-pic.png	4/6/2016 1:05 AM	PNG File	9 KB
Pepperl-Fuchs_plug_cqin_nc_4pol-con-pic.png	4/6/2016 1:08 AM	PNG File	11 KB
Pepperl-Fuchs-logo.png	3/10/2009 8:57 AM	PNG File	3 KB
Pepperl-Fuchs-R103nlc_cable-pic.png	11/29/2018 5:50 AM	PNG File	96 KB
Pepperl-Fuchs-R103nlc_plug-pic.png	11/29/2018 5:50 AM	PNG File	99 KB
Pepperl-Fuchs-R103nlc-icon.png	11/29/2018 5:50 AM	PNG File	5 KB

3. Click **Attached Devices** and **IODD FILES**.
4. Check the row that you want to update.
5. Click the **UPLOAD FILE** button.
6. Click the **CHOOSE FILE** button and browse to the file location.
7. Highlight the xml or image file and click **Open**. The xml file must be loaded before the IOLM will load the associated image files.

8. Click the **UPLOAD** button.

IO-Link Device Description Files

User IODD files (click filename to view)

VENDOR	DEVICE	IODD FILENAME	DEVICE IMAGE	VENDOR IMAGE	SIZE	
1	3146497	Pepperl_Fuchs-UC400_F77-20181030-IODD1.1.xml	pepperl_fuchs-uc-f77-pic.png	pepperl_fuchs-logo.png	176K	<input type="checkbox"/>
1	1120513	Pepperl-Fuchs-OMT550-R200-20190330-IODD1.1.xml	pepperl-fuchs-r200_cable-pic.png	pepperl-fuchs-logo.png	251K	<input type="checkbox"/>
1	2097921	Pepperl-Fuchs-PMI80-F90-IU-IO-20180320-IODD1.1.xml	pepperl-fuchs-pmi80-f90-pic.png	pepperl-fuchs-logo.png	185K	<input type="checkbox"/>
1	1115139	Pepperl-Fuchs_OBE10M-S_R103-20181215-IODD1.0.1.xml	pepperl-fuchs-r103n1c_cable-pic.png	pepperl-fuchs-logo.png	174K	<input checked="" type="checkbox"/>

CHOOSE FILE Pepperl-Fuch...DD1.1.xml **UPLOAD** CANCEL DELETE SELECTED

IODD files may be downloaded from the IODD-Finder at ioddfinder.io-link.com.

Standard IO-Link Definitions

Welcome Admin © Pepperl+Fuchs

9. Click the **Continue** button to the *Overwrite* message.
 Notice that the 1.1 xml file is now loaded.

IO-Link Device Description Files

IODD Benutzerdateien (klicken Sie den Dateinamen zu sehen)

VENDOR ID	DEVICE ID	IODD DATEINAME	DEVICE IMAGE	VENDOR IMAGE	SIZE	
1	3146497	Pepperl_Fuchs-UC400_F77-20181030-IODD1.1.xml	pepperl_fuchs-uc-f77-pic.png	pepperl_fuchs-logo.png	176K	<input type="checkbox"/>
1	1120513	Pepperl-Fuchs-OMT550-R200-20190330-IODD1.1.xml	pepperl-fuchs-r200_cable-pic.png	pepperl-fuchs-logo.png	251K	<input type="checkbox"/>
1	2097921	Pepperl-Fuchs-PMI80-F90-IU-IO-20180320-IODD1.1.xml	pepperl-fuchs-pmi80-f90-pic.png	pepperl-fuchs-logo.png	185K	<input type="checkbox"/>
1	1115139	Pepperl-Fuchs_OBE10M-S_R103-20181215-IODD1.1.xml	pepperl-fuchs-r103n1c_cable-pic.png	pepperl-fuchs-logo.png	174K	<input type="checkbox"/>

LADEN DATEI IODD Raum: 792K verbraucht, 15592K verfügbar SELEKTIERTE LÖSCHEN

IODD-Dateien können vom IODD-Finder auf ioddfinder.io-link.com heruntergeladen werden.

IODD Standarddefinitionen

Welcome Admin © Pepperl+Fuchs

10. Optionally, verify that the correct **xml** file was loaded for this IO-Link device using the **Summary** page (Page 111).

7.1.5. Viewing IODD Files

Use the following procedure to view the contents of an IODD file.

1. If necessary, click **Attached Devices** and **IODD Files**.
2. Click the **IODD FILENAME** in the table that you want to review. A pop up window displays the contents of the IODD file.

IO-Link Device Description Files

IODD Benutzerdateien (klicken Sie den Dateinamen zu sehen)

VENDOR ID	DEVICE ID	IODD DATEINAME	DEVICE IMAGE	VENDOR IMAGE	SIZE
1	3146497	Pepperl_Fuchs-UC400_F77-20181030-IODD1.1.xml	pepperl_fuchs-uc-f77-pic.png	pepperl_fuchs-logo.png	176K
1	1120513	Pepperl-Fuchs-OMT550-R200-20190330-IODD1.1.xml	pepperl_fuchs-r200_cable-pic.png	pepperl_fuchs-logo.png	251K
1	2097921	Pepperl-Fuchs-PMI80-F90-IU-IO-20180320-IODD1.1.xml	pepperl_fuchs-pmi80-f90-pic.png	pepperl_fuchs-logo.png	185K
1	1115139	Pepperl-Fuchs_OBE10W-S_R103-20181215-IODD1.1.xml	pepperl_fuchs-r103n1c_cable-pic.png	pepperl_fuchs-logo.png	174K

LADEN DATEI IODD Raum: 792K verbraucht, 15592K verfügbar SELEKTIERTE LÖSCHEN

IODD-Dateien können vom IODD-Finder auf ioddfinder.io-link.com heruntergeladen werden.

IODD Standarddefinitionen

10.8.11.180/index.php/view_uploaded_iodd_files/1/3146497/Pepperl_Fuchs-UC400_F77-20181030-IODD1.1.xml © Pepperl+Fuchs

3. Click the hyperlink at the top of the page if you want to view the **xml** file in your browser.

Pepperl Fuchs-UC400 F77-20181030-IODD1.1.xml

```
<?xml version='1.0' encoding='UTF-8'?>
<IODevice xmlns="http://www.io-link.com/IODD/2010/10"
xmlns:xsi="http://www.w3.org/2001/XMLSchema-instance"
xsi:schemaLocation="http://www.io-link.com/IODD/2010/10
IODD1.1.xsd">
  <DocumentInfo version="V1.00.002" releaseDate="2018-10-30"
copyright="Copyright 2018, Pepperl+Fuchs GmbH"/>
  <ProfileHeader>
    <ProfileIdentification>IO Device
Profile</ProfileIdentification>
    <ProfileRevision>1.1</ProfileRevision>
    <ProfileName>Device Profile for IO Devices</ProfileName>
    <ProfileSource>IO-Link Consortium</ProfileSource>
    <ProfileClassID>Device</ProfileClassID>
    <ISO15745Reference>
      <ISO15745Part>1</ISO15745Part>
    </ISO15745Reference>
  </ProfileHeader>
</IODevice>
```

4. Optionally, verify that the correct **xml** file was loaded using the **Summary** page (Page 111).

7.1.6. Deleting IODD Files

Use the following procedure to delete an IODD file set from the IO-Link master.

1. If necessary, click **Attached Devices** and **IODD Files**.
2. Check the corresponding row of the IODD file that you want to delete.

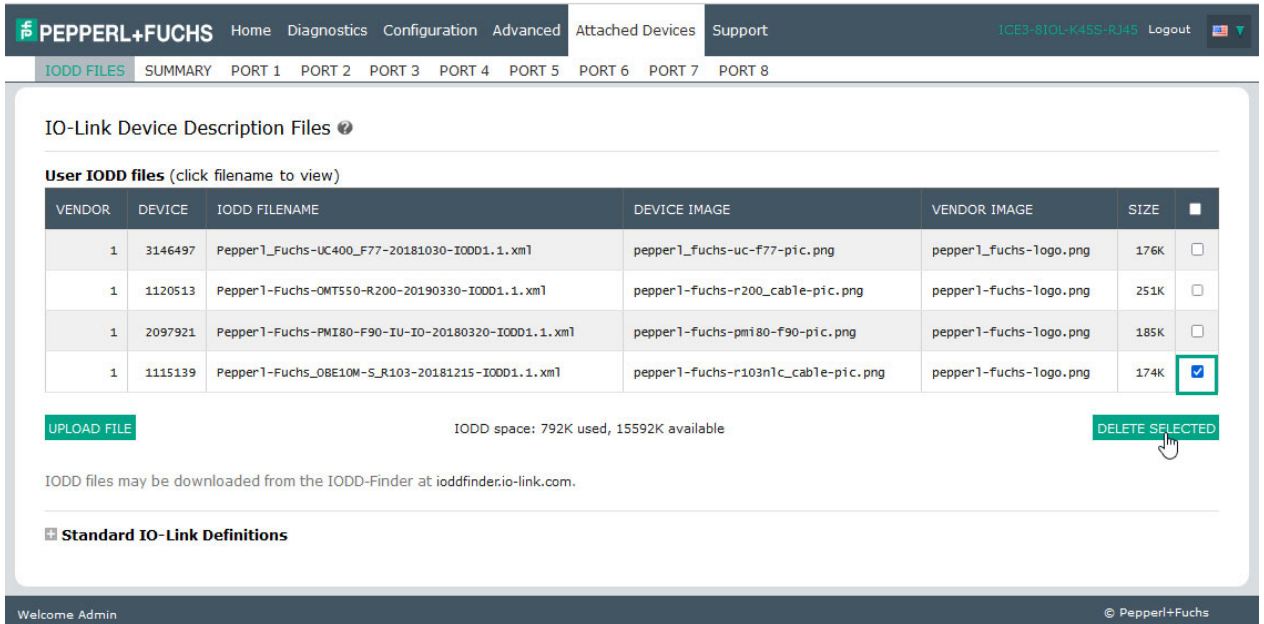

3. Click the **DELETE SELECTED** button.
4. Click **CONTINUE** to the *Delete files?* message.

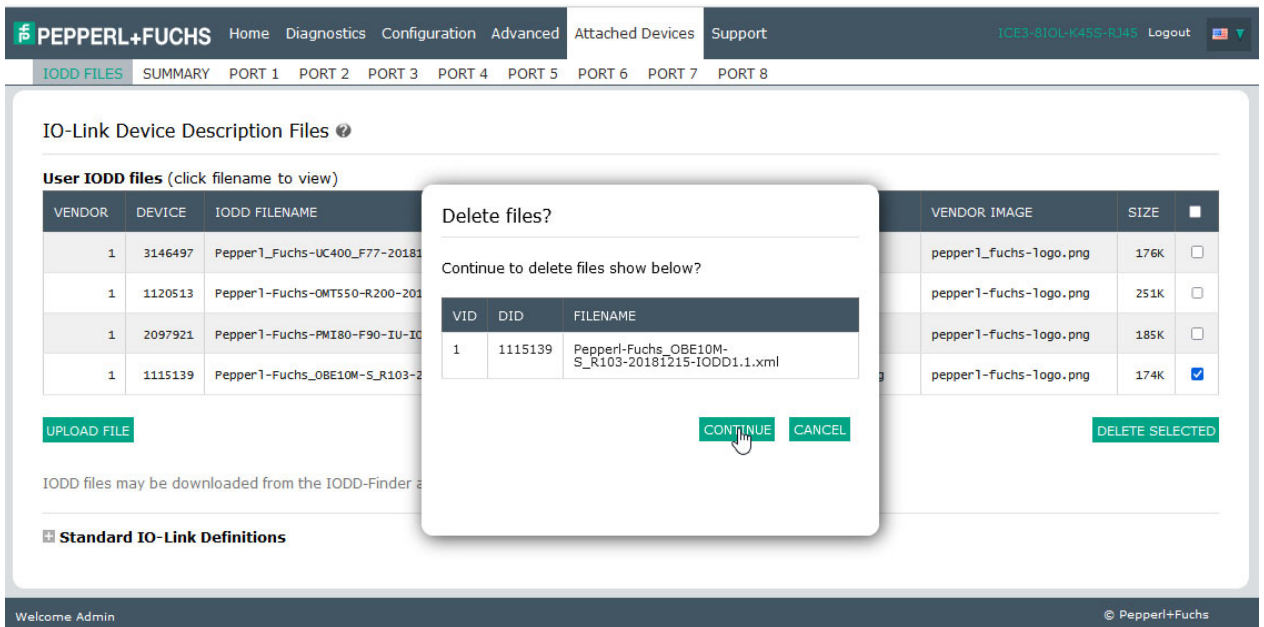

7.2. IO-Link Device Configuration Summary Page

The **IO-Link Device Configuration Summary** page provides basic device configuration (device profile) information for ports with valid IO-Link devices attached. The **Configuration Summary** page retrieves information that resides on the IO-Link device from the manufacturer.

A file name displayed in the **IODD Name** field for a port indicates that a valid IODD file is associated with that device. If the field is empty, that indicates that a valid IODD file has not been loaded.

You can review complete IODD file information on a port by port basis by clicking the **MORE** button next to the port in question or by clicking the **PORT** menu selection in the navigational bar.

Use the following steps to access the **IO-Link Device Configuration Summary** page.

1. Click **Attached Devices**.
2. Click **SUMMARY**.

Note: *The Configuration Summary page takes several minutes to completely load as each device is queried.*

3. Click the **MORE** button or the corresponding **Port** (in the navigational bar) to configure the IO-Link device parameters for a specific device. See *Configuring IO-Link Devices* on Page 112 for more information.

The screenshot shows the 'IO-Link Device Configuration Summary' page. At the top, there is a navigation bar with 'PEPPERL+FUCHS' logo and menu items: Home, Diagnostics, Configuration, Advanced, Attached Devices, Support. Below this is a sub-navigation bar with 'IODD FILES', 'SUMMARY', and 'PORT 1' through 'PORT 8'. The main content area is titled 'IO-Link Device Configuration Summary' and contains a table with the following data:

DEVICE SETTINGS	PORT 1	MORE	PORT 2	MORE	PORT 3	MORE	PORT 4	MORE	PORT 5
Vendor Name	Pepperl+Fuchs						Pepperl+Fuchs		
VENDOR	1						1		
DEVICE	3146497						2097921		
Description	Ultrasonic Sensor UC-F77, 400mm, M8 plug, 4-pin						1x Analog (I/U), IO-Link		
IO-Link Version	1.1						1.1		
Hardware Version	HW01.00						HW01.00		
Firmware Version	FW01.00						FW01.00		
Baud Rate	38400						38400		
SIO Mode	Yes						Yes		
Min Cycle Time	2.3 ms						2.3 ms		
IODD Name	Pepperl_Fuchs-UC400_F77-20181030-IODD1.1.xml						Pepperl-Fuchs-PMI80-F90-IU-IO-20180320-IODD1.1.xml		

At the bottom of the page, there is a footer with 'Welcome Admin' on the left and '© Pepperl+Fuchs' on the right.

8. Configuring IO-Link Devices

This chapter discusses using the **Attached Devices | Port** pages to change IO-Link device parameters.

Note: *Optionally, you can use traditional methods such as: PLC interfaces or HMI/SCADAs, depending on your protocol to configure the IO-Link devices.*

8.1. Port Pages Overview

You can use the **Attached Devices | Port** page for a port to review and easily edit the IO-Link device configuration or view Process Data. Collapse or expand parameters groups by clicking the + or -. If you collapse a group before the page completely loads and then open the group, it will need to load the parameters.

The screenshot shows the 'IO-Link Device - Port 1' configuration page. At the top, there is a navigation bar with 'Home', 'Diagnostics', 'Configuration', 'Advanced', 'Attached Devices', and 'Support'. Below this is a sub-menu for 'PORT 1' through 'PORT 8'. The main content area features a table with columns: Parameter Name, Index, Subindex, Value, Description, R/W, Unit, Min, Max, and Comments. The table is organized into expandable sections: '- Sensor information', '- Device information', '+ User specific information', '+ Revision information', '+ Configuration', and '+ Diagnosis'. The 'Device information' section is expanded, showing parameters like Vendor Name, Vendor Text, Product Name, Product Text, Product ID, and Serial Number. At the bottom, there is a status bar indicating 'IO-Link Device ISDU Interface - Port 1' and 'Port Status: Operational, PDI Valid'.

Parameter Name	Index	Subindex	Value	Description	R/W	Unit	Min	Max	Comments
- Sensor information									
- Device information									
Vendor Name	16		Pepperl+Fuchs		RO				
Vendor Text	17		www.pepperl-fuchs.com/io-link		RO				
Product Name	18		UC400-F77-EP-IO-V31		RO				
Product Text	20		Ultrasonic distance sensor		RO				
Product ID	19		261243		RO				
Serial Number	21		40000069832283		RO				
+ User specific information									
+ Revision information									
+ Configuration									
+ Diagnosis									

The **Port** page provides two IO-Link device configuration methods:

- **IO-Link Device Port** table (GUI), which depends on the appropriate IODD file loaded from the IO-Link device manufacturer onto the IO-Link master. To use the **IO-Link Device Port** table for configuring IO-Link devices, refer to the following subsections:
 - *Editing Parameters - IO-Link Device - Port Table* on Page 116
 - *Resetting IO-Link Device Parameters to Factory Defaults* on Page 118
- **IO-Link Device ISDU Interface - Port**, which can be used with or without IODD files loaded. Refer to the following information to use the **IO-Link Device ISDU Interface - Port** method:
 - The *IO-Link Device Operator Manual* from the device manufacturer is needed to use the **IO-Link Device ISDU Interface** since ISDU block index and ISDU sub-index numbers are required.
 - *Editing Parameters - IO-Link Device ISDU Interface - Port* on Page 120

The **IO-Link Device Port** table provides detailed information about the indexes and sub-indexes. Not all indexes have sub-indexes. In the following image, Index 60 has two sub-indexes, Sub-index 1 and Sub-index 2 that both contain 16 bits.

Parameter Name	Index	Subindex	Value	Description	R/W	Unit	Min	Max	Comments
+ Sensor information									
- Configuration									
- Output configuration									
- Output 1									
Switch Point 1	60	1	40	30~680	RW	mm	30	680	value range:30~680
Switch Point 2	60	2	400	Same as previous description	RW	mm	30	680	value range:30~680
Output mode	61	2	2	1:Switchpoint mode 2:Window mode 3:Hysteresis mode 128:Retroreflective mode	RW		1	128	value range:1;2;3;128
Output logic	61	1	0	0:Normally open 1:Normally closed	RW		0	1	value range:0;1
Output Type	112	1	0	0:Push-pull 1:Sourcing (PNP) 2:Sinking (NPN)	RW		0	2	value range:0;1;2
Retroreflective mode offset	64	1	20	1~200	RW	mm	1	200	value range:1~200
Switching hysteresis	61	3	0	0:Low 1:Medium 2:High	RW		0	2	value range:0;1;2
On delay	64	3	0	0~60000	RW	ms	0	60000	value range:0~60000
Off delay	64	2	0	Same as previous description	RW	ms	0	60000	value range:0~60000

IO-Link Device ISDU Interface - Port 1 Port Status: Operational, PDI Valid

- If the IODD file follows IO-Link specifications, an asterisk next to RW means that parameter is not included in Data Storage.
- If a Sub-index has an asterisk next to it in the GUI, that means that sub-index is not sub-indexable. This may be useful information when using the IO-Link Device ISDU Interface or programming your PLC.



This example shows that Index 109 contains 10 sub-indices.

When you perform a **GET** on Index 109 using the ISDU Interface, these are the results:

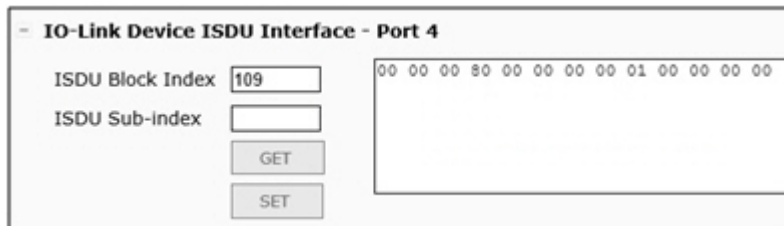

109	1*
109	2*
109	3*
109	4*
109	5*
109	6*
109	7*
109	8*
109	9*
109	10*

The GUI displays this information about Index 109.

Index	Subindex	Value	Description	R/W	Unit	Min	Max	Comments	Gradient	Offset	Data Type	SimpleDatatype	BitLength
109	1*	2246		RO				dynamic parameter			RecordT	UIntegerT	16
109	2*	2515		RO				dynamic parameter			RecordT	UIntegerT	16
109	3*	3		RO				dynamic parameter			RecordT	UIntegerT	8
109	4*	1		RO				dynamic parameter			RecordT	UIntegerT	8
109	5*	1		RO				dynamic parameter			RecordT	UIntegerT	8
109	6*	0		RO				dynamic parameter			RecordT	UIntegerT	8
109	7*	0		RO				dynamic parameter			RecordT	UIntegerT	8
109	8*	0		RO				dynamic parameter			RecordT	UIntegerT	16
109	9*	0		RO				dynamic parameter			RecordT	UIntegerT	8
109	10*	0		RO				dynamic parameter			RecordT	UIntegerT	8

Which can be illustrated as:

00 00 | 00 80 | 00 | 00 | 00 | 00 | 01 | 00 00 | 00 | 00
 1 | 2 | 3 | 4 | 5 | 6 | 7 | 8 | 9 | 10

Access the **Process Data** page by selecting **Process Data** from the drop box next to the port number.

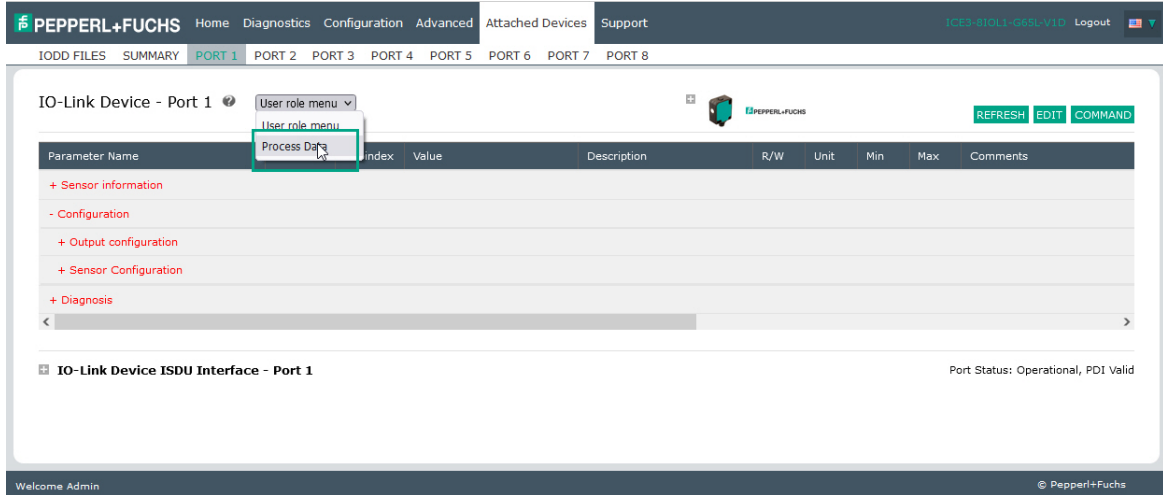

This shows a typical **Process Data** page.

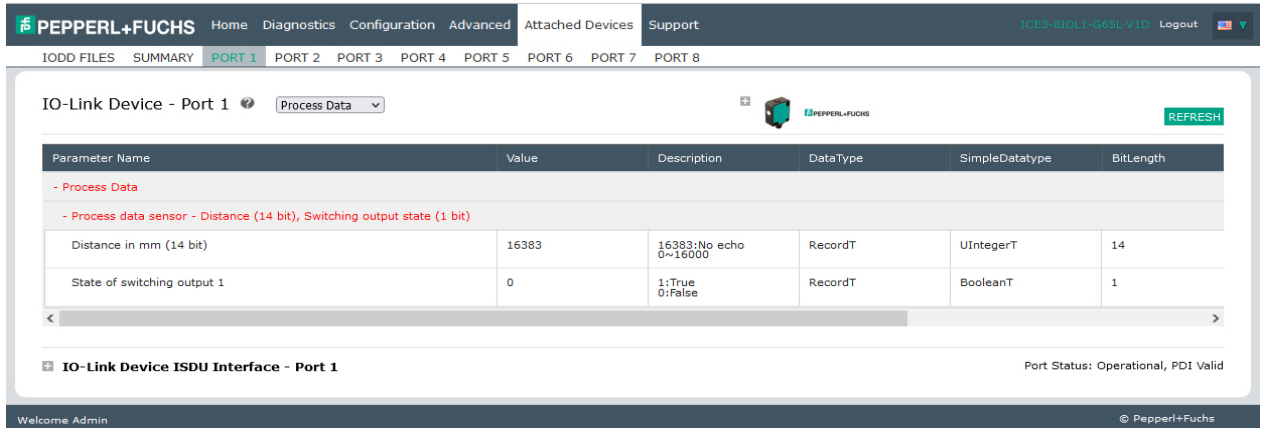

If the incorrect IODD file has been loaded, then you will receive this message.

No Process Data

Unable to load the Process Data! Make sure the attached IO-Link device is supported and the corresponding IODD file is loaded.



8.2. Editing Parameters - IO-Link Device - Port Table

Use the following procedure to edit IO-Link device parameters using the **IO-Link Device Port** table.

Note: You may want to verify that the **Automatic Download Enable for Data Storage** option on the *Configuration \ IO-Link Settings* page is **NOT** set to **On** as this can cause unreliable results on the corresponding port.

1. If you have not done so, load the IODD file from the IO-Link device manufacturer (*Loading and Managing IODD Files* on Page 102).
2. Access the appropriate **Port** page by clicking **Attached Devices** and then the **Port** number that you want to configure.
3. Click the **EDIT** button after all of the device information is populated in the table.
4. Scroll down the table and make appropriate parameter changes for your environment.

Note: An IODD file may not contain all IO-Link device settings depending on the IO-Link device manufacturer. If you need to change a parameter that is not displayed in the **IO-Link Device - Port** table, you can refer to the *IO-Link Device Operators Manual* and use the **IO-Link Device ISDU Interface** to change the settings.

You may need to scroll to the right in the table to view applicable parameter values if the parameter is not selectable in a drop list.

5. Click the **SAVE** button after editing the parameters.

IO-Link Device - Port 1

Parameter Name	Index	Subindex	Value	Description	R/W	Unit	Min	Max	Comments
- Sensor information									
+ Device information									
+ User specific information									
+ Revision information									
- Configuration									
- Output configuration									
- Output 1									
Switch Point 1	60	1	30	30~680	RW	mm	30	680	value range:30~680
Switch Point 2	60	2	300	Same as previous description	RW	mm	30	680	value range:30~680
Output mode	61	2	128	1:Switchpoint mode 2:Window mode 3:Hysteresis mode 128:Retrospective mode	RW		1	128	value range:1;2;3;128
Output logic	61	1	0	0:Normally open 1:Normally closed	RW		0	1	value range:0;1
Output Type	112	1	0	0:Push-pull 1:Sourcing (PNP)	RW		0	2	value range:0;1;2

IO-Link Device ISDU Interface - Port 1 Port Status: Operational, PDI Valid

6. Verify that the changes took affect.

The screenshot shows the configuration page for an IO-Link Device on Port 1. The interface includes a navigation bar with 'PEPPER+FUCHS', 'Home', 'Diagnostics', 'Configuration', 'Advanced', 'Attached Devices', and 'Support'. Below the navigation bar, there are tabs for 'PORT 1' through 'PORT 8'. The main content area is titled 'IO-Link Device - Port 1' and contains a table of parameters. The 'Value' column for 'Switch Point 1' is highlighted with a green box, showing the value 30. Other parameters include 'Switch Point 2', 'Output mode', 'Output logic', 'Output Type', 'Retroreflective mode offset', and 'Switching hysteresis'. The bottom of the page shows 'IO-Link Device ISDU Interface - Port 1' and 'Port Status: Operational, PDI Valid'.

Parameter Name	Index	Subindex	Value	Description	R/W	Unit	Min	Max	Comments
+ Sensor information									
- Configuration									
- Output configuration									
- Output 1									
Switch Point 1	60	1	30	30~680	RW	mm	30	680	value range:30~680
Switch Point 2	60	2	300	Same as previous description	RW	mm	30	680	value range:30~680
Output mode	61	2	128	1:Switchpoint mode 2:Window mode 3:Hysteresis mode 128:Retroreflective mode	RW		1	128	value range:1;2;3;128
Output logic	61	1	0	0:Normally open 1:Normally closed	RW		0	1	value range:0;1
Output Type	112	1	0	0:Push-pull 1:Sourcing (PNP) 2:Sinking (NPN)	RW		0	2	value range:0;1;2
Retroreflective mode offset	64	1	20	1~200	RW	mm	1	200	value range:1~200
Switching hysteresis	61	3	0	0:Low 1:Medium 2:High	RW		0	2	value range:0;1;2

8.3. Resetting IO-Link Device Parameters to Factory Defaults

In the event you want to reset the IO-Link device to factory default, typically the IODD file provides the ability from the IO-Link device manufacturer. Use the following example to reset an IO-Link device.

1. Click the **COMMAND** button and locate the **Restore Factory** button.
2. Click the **Restore Factory** or **Load Factory Settings** button.

Note: The name of the button is determined by the IO-Link device manufacturer.

The screenshot shows the Pepperl+Fuchs web interface for configuring an IO-Link device. The top navigation bar includes 'Home', 'Diagnostics', 'Configuration', 'Advanced', 'Attached Devices', and 'Support'. The main content area is titled 'IO-Link Device - Port 1' and features a 'User role menu' dropdown. A table lists parameters, with the 'Factory Settings' section expanded to show a 'Restore Factory' button. A tooltip 'Restore Factory Settings' is displayed over the button. The bottom status bar shows 'Port Status: Operational, PDI Valid' and 'Welcome Admin'.

Parameter Name	Index	Subindex	Value	Description	R/W	Unit	Min	Max	Comments
+ Sensor information									
+ Configuration									
- Diagnosis									
- Factory Settings									
Standard Command	2		Restore Factory	130:Restore Factory Settings	WO		130	130	value range:130
+ Service Function									
+ Operation Information									
+ Communication Characteristics									

3. Click **OK** when the *Refresh* message appears.

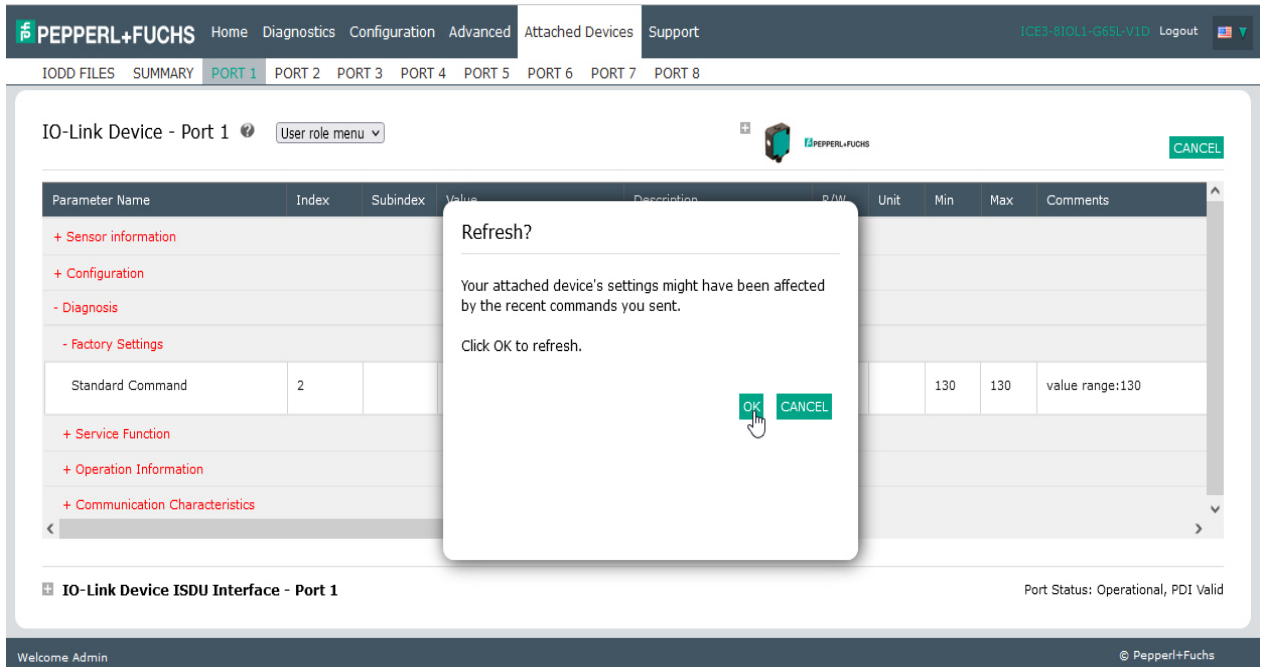

The screenshot shows the Pepperl+Fuchs web interface for an IO-Link device. A modal dialog box titled "Refresh?" is displayed in the center. The dialog contains the following text: "Your attached device's settings might have been affected by the recent commands you sent. Click OK to refresh." There are two buttons at the bottom of the dialog: "OK" and "CANCEL". A mouse cursor is pointing at the "OK" button. In the background, a table lists parameters for the IO-Link Device ISDU Interface - Port 1. The table has columns for Parameter Name, Index, Subindex, Value, Description, PAM, Unit, Min, Max, and Comments. One row is visible with the parameter "Standard Command" at index 2, a value of 130, and a comment "value range:130".

Parameter Name	Index	Subindex	Value	Description	PAM	Unit	Min	Max	Comments
Standard Command	2		130				130	130	value range:130

4. Click the **Cancel** button to return to device configuration.

8.4. Editing Parameters - IO-Link Device ISDU Interface - Port

The **IO-Link Device ISDU Interface** follows these guidelines:

- If necessary, convert hexadecimal ISDU index numbers to decimal, you must enter the decimal value for the ISDU Block Index and ISDU Sub-index numbers.
- You must enter the hexadecimal value for the IO-Link device parameters.

If the appropriate IODD files has been loaded, you can use the **IO-Link Device - Port** table to determine the index numbers and acceptable values for each parameter.

Note: An IODD file may not contain every IO-Link device setting depending on the IO-Link device manufacturer. If you need to change a parameter that is not displayed in the **IO-Link Device - Port** table, you can refer to the *IO-Link Device Operators Manual*.

If an IODD file has not been loaded for an IO-Link device, you can use the *IO-Link Device Operator's Manual* to determine the ISDU indexes.

8.4.1. Overview

The following provides some basic information about the command usage and responses when using the ISDU Interface.

- You must enter the decimal value for the ISDU Block Index and ISDU Sub-index.
- The **GET** button retrieves the parameter value in hex from the IO-Link device. You may want to retrieve values to determine the data length.

IO-Link Device ISDU Interface - Port 1 Port Status: Operational, PDI Valid

ISDU Block Index 00 28 01 90

ISDU Sub-index

1.

2.

- First, type the hex value that you want to change, click the **SET** button, and the value is sent to the IO-Link device.

IO-Link Device ISDU Interface - Port 1 Port Status: Operational, PDI Valid

ISDU Block Index 00 1e 01 90

ISDU Sub-index

2. **1.**



- After successfully changing a parameter, the IO-Link master responds with a command executed notification.

IO-Link Device ISDU Interface - Port 1

Port Status: Operational, PDI Valid

ISDU Block Index

ISDU Sub-index

GET

SET

command executed

9. Utilizing IO-Link master Features

This chapter discusses using the following features:

- *Setting User Accounts and Passwords*
- *Data Storage* on Page 124, which provides automatic and manual data storage to upload or download IO-Link v1.1 device parameters
- *Device Validation* on Page 128, which supports identical or compatible device validation to dedicate a port or ports to specific IO-Link devices
- *Data Validation* on Page 129, which supports strict or loose data validation to verify data integrity
- *IO-Link master Configuration Files* on Page 130 that supports a method to back up configuration files or load the same configuration to multiple IO-Link master units
- *Configuring Miscellaneous Settings* on Page 132, which provides the following options:
 - *Using the Menu Bar Hover Shows Submenu Option* on Page 133
 - *Enable PDO Write From Attached Devices Port Page* on Page 133
 - *IO-Link Test Event Generator* on Page 134
- *Clearing Settings* on Page 137, which allows you to reset the IO-Link master to factory default values

Note: You must configure data storage, device validation, data validation in PROFINET IO using Step 7 or the TIA Portal. You can use data storage on the web page for temporary data storage related tasks.

9.1. Setting User Accounts and Passwords

The IO-Link master is shipped from the factory without passwords. See the following table if you want to see how permissions are granted.

Page Permissions	Admin	Operator	User
Log-in	Yes	Yes	Yes
Home	Yes	Yes	Yes
Diagnostics - All	Yes	Yes	Yes
Configuration - IO-Link Settings	Yes	Yes	View-only
Configuration - Modbus/TCP	Yes	Yes	View-only
Configuration - PROFINET IO	Yes	Yes	View-only
Configuration - OPC UA	Yes	Yes	View-only
Configuration - MQTT	Yes	Yes	View-only
Configuration - Network	Yes	View-only	No
Configuration - Misc	Yes	Yes	Yes
Configuration - Load/Save	Yes	Yes	View-only
Configuration - Clear Settings	Yes	No	No
Advanced - Software	Yes	No	No
Advanced - Accounts	Yes	No	No

Page Permissions (Continued)	Admin	Operator	User
Advanced - Log Files	Yes	Yes	Yes
Advanced - Licenses	Yes	Yes	Yes
Attached Devices - IO-Link Device Description Files	Yes	Yes	View-only
Attached Devices - IO-Link Device Configuration Summary	Yes	Yes	View-only
Attached Devices - IO-Link Device - Port	Yes	Yes	View-only

You can use this procedure to set up passwords for the IO-Link master.

1. Open your browser and enter the IO-Link master IP address.
2. Click **Advanced | ACCOUNTS**.
3. Click the **ADMIN** check box.
4. If applicable, enter the old password in the **Old Password** text box.
5. Enter the new password in the **New Password** text box.
6. Re-enter the password in the **Confirm Password** text box.

7. Optionally, click the **Operator** check box, enter a new password, and re-enter the password in the **Confirm Password** text box.
8. Optionally, click the **User** check box, enter the new password, and re-enter the password in the **Confirm Password** text box.
9. Click **Apply**.

10. Close the new window that displays a *Password saved* banner.

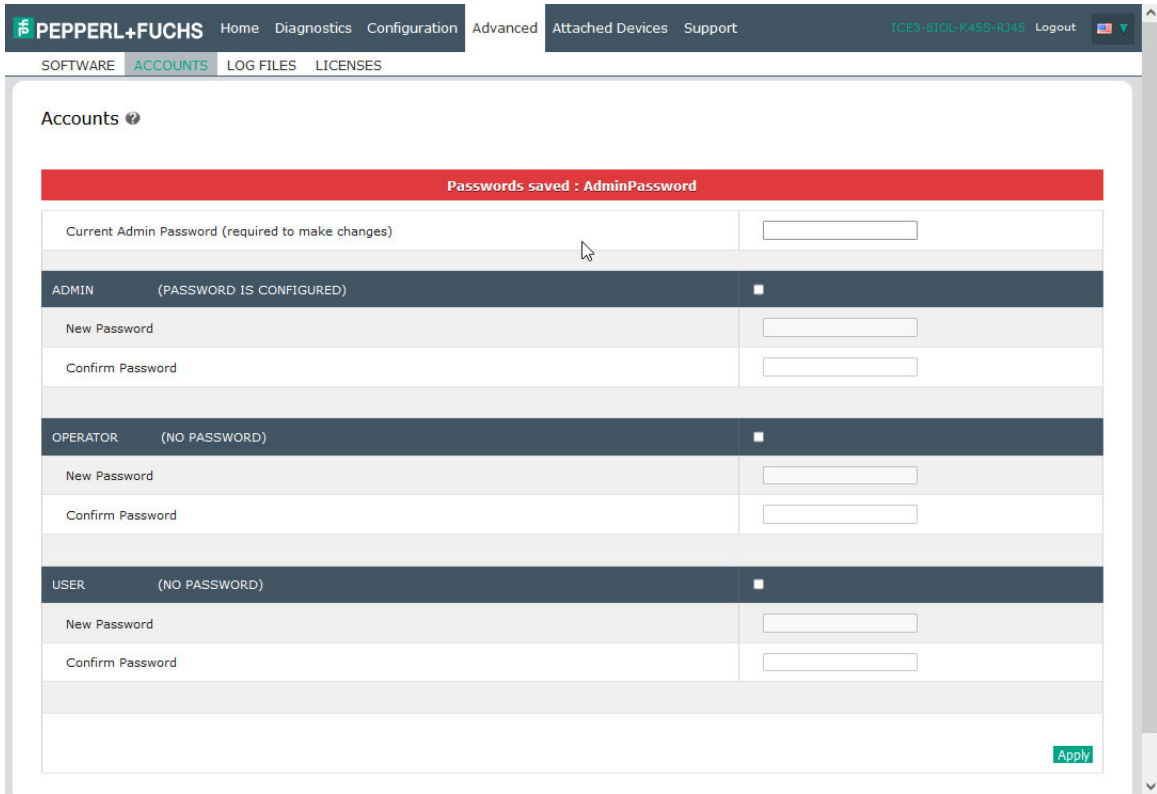

11. Click the **Log out** button on the top navigation bar.

12. Re-open the web interface by selecting the appropriate user type in the drop list and entering the password.

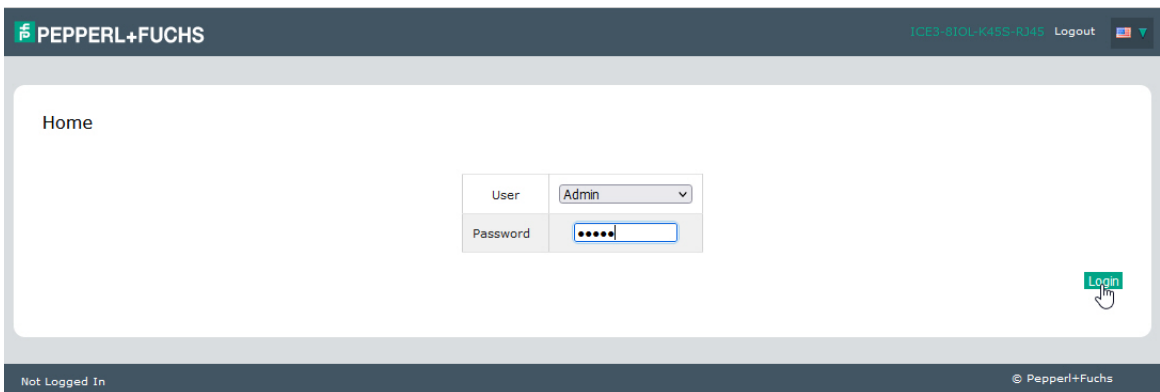

9.2. Data Storage

Data storage is typically supported by IO-Link v1.1 devices. *Data storage* means that you can upload parameters from an IO-Link device to the IO-Link master and/or download parameters from the IO-Link master to the IO-Link device. This feature can be used to:

- Quickly and easily replace a defective IO-Link device
- Configure multiple IO-Link devices with the same parameters as fast as it takes to connect and disconnect the IO-Link device

To determine whether an IO-Link (v1.1) device supports data storage, you can check one of the following:

- **IO-Link Diagnostics** page - check the **Data Storage Capable** field to see if it displays **Yes**.
- **IO-Link Configuration** page - check to see if **UPLOAD** and **DOWNLOAD** buttons display under the **Data Storage Manual Ops** group. If only a **Clear** button displays, the device on the port does not support data storage.

Although you can make configuration changes using the web page, PROFINET IO configuration parameters overwrite the values on the **IO-Link Settings** page. See *IO-Link Port Settings (IO-Link Port Module Parameters)* on Page 46 for PROFINET IO configuration procedures.

9.2.1. Uploading Data Storage to the IO-Link master

The IO-Link device manufacturer determines which parameters are saved for data storage. Remember, the IO-Link device should be configured before enabling data storage unless you are using data storage to back up the default device configuration.

There are two methods to upload Data Storage using the **Configuration | IO-Link** page:

- **Automatic Enable Upload** - If a port is set to **On** for this option, the IO-Link master saves the data storage parameters (if the data storage is empty) from the IO-Link device to the IO-Link master.

When this option is enabled and another IO-Link device (different Vendor ID and Device ID), the **IO-Link Diagnostics** page displays a *DS: Wrong Sensor* in the **IO-Link State** field and the IO-Link port LED flashes red, indicating a hardware fault.

Automatic upload occurs when the **Automatic Upload Enable** option is set to **On** and one of these conditions exists:

- There is no upload data stored on the gateway and the IO-Link device is connected to the port.
- The IO-Link device has the **DS upload** bit on; generally because you have changed the configuration through Teach buttons or the web interface.

Note: *Not all device parameters are sent to data storage. The IO-Link device manufacturer determines what parameters are sent to data storage.*

- **Data Storage Manual Ops: UPLOAD** - Selecting the **UPLOAD** button saves the data storage from the IO-Link device to the IO-Link master. The contents of the data storage does not change unless it is uploaded again or cleared. Another IO-Link device with a different Vendor ID and Device ID can be attached to the port without causing a hardware fault.

9.2.2. Downloading Data Storage to the IO-Link Device

There are two methods to download Data Storage using the **Configuration | IO-Link Device** page:

- **Automatic Download Enable** - An automatic download occurs when the **Automatic Download Enable** option is set to **On** and one of these conditions exists:
 - The original IO-Link device is disconnected and an IO-Link device whose configuration data differs from the stored configuration data.
 - The IO-Link device requests an upload and the **Automatic Upload Enable** option is set to **Off**.

- **Data Storage Manual Ops: DOWNLOAD - Selecting the DOWNLOAD** button downloads the data storage from the that port to the IO-Link device.
If an IO-Link device with a different Vendor ID and Device ID is attached to the port and a manual download is attempted, the IO-Link master issues a hardware fault.

9.2.3. Automatic Device Configuration

Use the following steps to use an IO-Link master port to configure multiple IO-Link devices with the same configuration parameters.

Note: You must configure data storage in PROFINET IO using Step 7 or TIA Portal. You can use data storage on the web page for temporary data storage related tasks.

1. If necessary, configure the IO-Link device as required for the environment.
2. Click **Configuration| IO-Link**.
3. Click the **EDIT** button for the port for which you want to store the data on the IO-Link master.
4. Click the **UPLOAD** button.
5. Click the **CONTINUE** button to the *Continue to upload the data storage on IO-Link master port [number]* message.

The screenshot shows the 'IO-Link Settings' web interface. At the top, there is a navigation bar with 'PEPPERL+FUCHS' and various menu items like 'Home', 'Diagnostics', 'Configuration', 'Advanced', 'Attached Devices', and 'Support'. Below this is a sub-navigation bar with 'IO-LINK', 'PROFINET IO', 'MODBUS/TCP', 'OPC UA', 'MQTT', 'NETWORK', 'MISC', 'LOAD/SAVE', and 'CLEAR SETTINGS'. The main content area is titled 'IO-Link Settings' and contains a table for 'IO-LINK PORT CONFIG'. The table has columns for 'PORT 1', 'PORT 4', and 'PORT 8'. Each column has an 'EDIT' button. The 'UPLOAD' button for PORT 1 is highlighted with a red box. A modal dialog box titled 'Continue?' is overlaid on the table, with the text: 'This operation may take up to a minute. Continue to upload the data storage on IO-Link Master port 1?'. The dialog has 'CONTINUE' and 'CANCEL' buttons. The 'CONTINUE' button is highlighted with a red box. At the bottom of the page, there is a footer with 'Welcome Admin' and '© Pepperl+Fuchs'.

- Click the **OK** button to the *Data storage upload successful on Port [number]* message.



- Set the **Automatic Download Enable** option to **On**.
- Click **SAVE**.

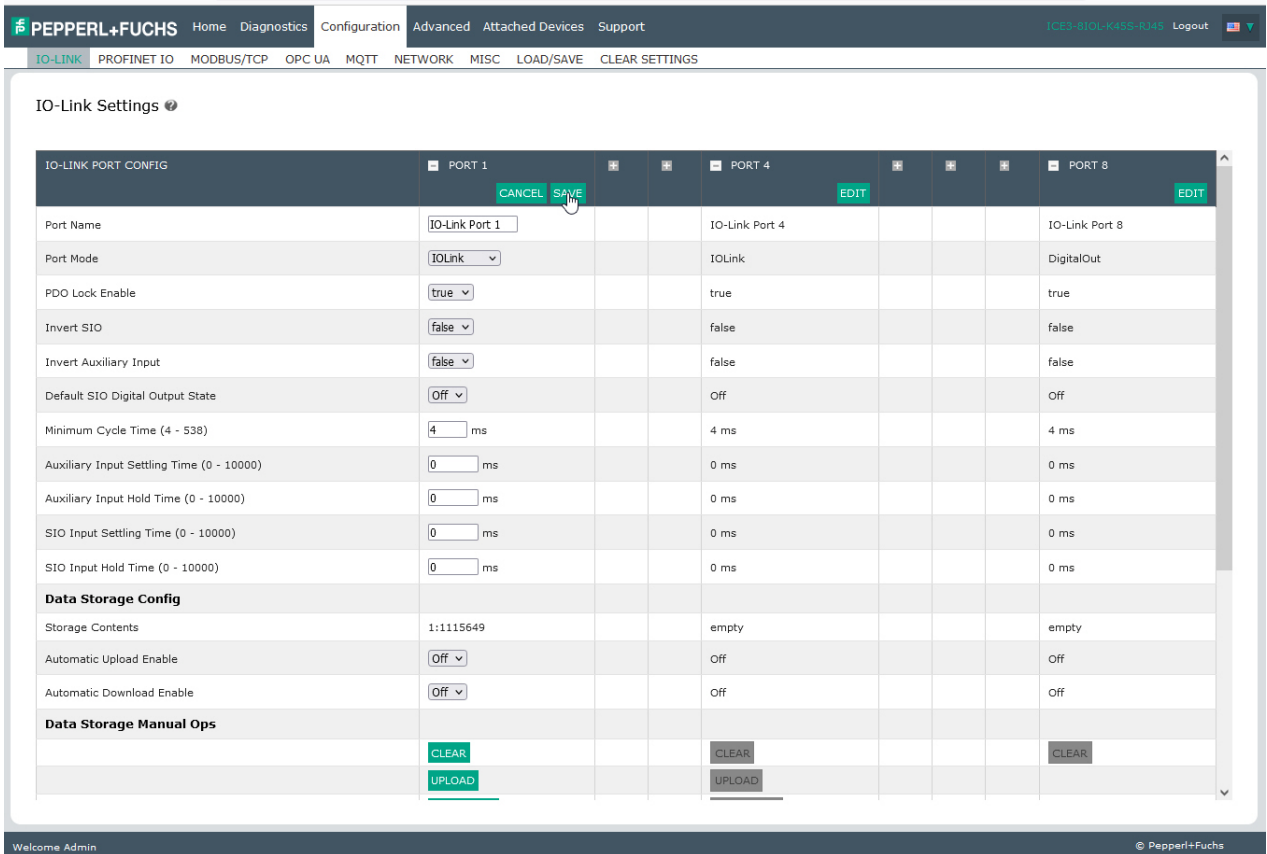

- Click **Diagnostics | IO-Link**.
- Replace the IO-Link device on that port with the IO-Link device for which you want configured automatically.
- Verify that the IO-Link device displays operational **Port Status** and the appropriate IO-Link State.
- Repeat Steps 10 and 11 for as many device as you want to configure.

9.2.4. Automatic Device Configuration Backup

The following procedure shows how to utilize data storage to automatically backup an IO-Link device configuration.

Note: You must configure data storage in PROFINET IO using Step 7 or TIA Portal. You can use data storage on the web page for temporary data storage related tasks.

Remember, if you adjust parameters using **Teach** buttons those values may or not may be updated in the data storage, which depends on the IO-Link device manufacturer. If you are unsure, you can always use the manual **UPLOAD** feature to capture the latest settings.

1. Click **Configuration | IO-Link**.
2. Click the **EDIT** button for the port for which you want to store the data on the IO-Link master.
3. Select **On** in the drop list for **Automatic Data Storage Upload Enable**.

The screenshot shows the 'IO-Link Settings' page for 'PORT 4'. The 'Automatic Upload Enable' dropdown menu is open, and the 'On' option is selected. The 'SAVE' button is highlighted with a mouse cursor. The 'Storage Contents' field is currently empty.

IO-LINK PORT CONFIG	PORT 1	PORT 4	PORT 8
Port Name	IO-Link Port 1	IO-Link Port 4	IO-Link Port 8
Port Mode	IOLink	IOLink	DigitalOut
PDO Lock Enable	true	true	true
Invert SIO	false	false	false
Invert Auxiliary Input	false	false	false
Default SIO Digital Output State	Off	Off	Off
Minimum Cycle Time (4 - 538)	4 ms	4 ms	4 ms
Auxiliary Input Settling Time (0 - 10000)	0 ms	0 ms	0 ms
Auxiliary Input Hold Time (0 - 10000)	0 ms	0 ms	0 ms
SIO Input Settling Time (0 - 10000)	0 ms	0 ms	0 ms
SIO Input Hold Time (0 - 10000)	0 ms	0 ms	0 ms
Data Storage Config			
Storage Contents	1:1115649	empty	empty
Automatic Upload Enable	Off	On	Off
Automatic Download Enable	Off	Off	Off
Data Storage Manual Ops			
	CLEAR	CLEAR	CLEAR
	UPLOAD	UPLOAD	

4. Click **SAVE**.

When the **Configuration | IO-Link** page is refreshed, the **Storage Contents** field displays the **Vendor ID** and **Device ID**. In addition, the **IO-Link Diagnostics** page displays **Upload-Only** in the **Automatic Data Storage Configuration** field.

9.3. Device Validation

Device validation is supported by many IO-Link devices. **Device Validation Mode** provides these options:

- **None** - this disables **Device Validation Mode**.
- **Compatible** - permits a compatible IO-Link device (same Vendor ID and Device ID) to function on the corresponding port.
- **Identical** - only permits an IO-Link device (same Vendor ID, Device ID, and serial number) to function on the corresponding port.

Although you can make configuration changes using the web page, PROFINET IO configuration parameters overwrite the values on the **IO-Link Settings** page. See *IO-Link Port Settings (IO-Link Port Module Parameters)* on Page 46 for PROFINET IO configuration procedures.

Use this procedure to configure device validation.

1. Click **Configuration | IO-Link Settings**.
2. Click the **EDIT** button.
3. Select **Compatible** or **Identical** for the **Device Validation mode**.

Note: *Identical Device Validation requires a device serial number to operate.*

4. Click the **GET ATTACHED** button or manually complete the Vendor ID, Device ID, and serial number.

If the device does not have a serial number, you should not select **Identical** because the IO-Link master requires a serial number to identify a specific device.

The screenshot shows the 'IO-Link Settings' page for three ports: IO-Link Port 1, IO-Link Port 4, and IO-Link Port 8. The 'Validation Config' section for Port 1 is highlighted with a box around the 'Compatible' dropdown menu. Other settings for Port 1 include Vendor ID (1), Device ID (1115649), and Serial Num (40000078765). The 'GET ATTACHED' button is also highlighted with a box. The 'SAVE' button is visible at the top of the settings table.

2022-12

5. Click the **SAVE** button. If the wrong or incompatible device is connected to the port, the IO-Link port LED flashes red and no IO-Link activity occurs on the port until the issue is resolved.

9.4. Data Validation

You can use this procedure to configure data validation.

Although you can make configuration changes using the web page, PROFINET IO configuration parameters overwrite the values on the **IO-Link Settings** page. See *IO-Link Port Settings (IO-Link Port Module Parameters)* on Page 46 for PROFINET IO configuration procedures.

1. Click **Configuration | IO-Link Settings**.
2. Click the **EDIT** button on the port you want to configure for data validation.
3. Select **Loose** or **Strict** to enable data validation.
 - **Loose** - the slave device's PDI/PDO lengths must be less than or equal to the user-configured values.
 - **Strict** - the slave device's PDI/PDO lengths must be the same as the user-configured values.
4. Click the **GET ATTACHED** button or manually enter the PDI and PDO length.

The screenshot shows the 'IO-Link Settings' web page. The 'Validation Config' section is expanded, showing the following configuration for the first port (IO-Link Port 1):

Parameter	IO-Link Port 1	IO-Link Port 2	IO-Link Port 3	IO-Link Port 4	IO-Link Port 5	IO-Link Port 6	IO-Link Port 7	IO-Link Port 8
Device Validation Mode	None	None	None	None	None	None	None	None
Vendor Id (0 - 65535)	1	0	0	0	0	0	0	0
Device Id (0 - 16777215)	1115649	0	0	0	0	0	0	0
Serial Num	4000007877651							
Data Validation Mode	Strict	None	None	None	None	None	None	None
PDI Length (0 - 32)	1 byte	0 byte	0 byte	0 byte	0 byte	0 byte	0 byte	0 byte
PDO Length (0 - 32)	1 byte	0 byte	0 byte	0 byte	0 byte	0 byte	0 byte	0 byte

The 'GET ATTACHED' button for the first port is highlighted with a red box.

5. Click the **SAVE** button.

If data validation fails, the IO-Link port LED flashes red and the **IO-Link Diagnostics** page displays an error.

9.5. IO-Link master Configuration Files

You can use the web interface or PortVision DX to save or load IO-Link master configuration files.

Note: You can optionally install and use PortVision DX to save or load IO-Link master configuration files. Download PortVision DX from <https://www.pepperl-fuchs.com>.

The configuration files includes the following:

- IO-Link master gateway settings, which includes the port settings, network settings, and encrypted passwords
- Data storage contents saved in the **IO-Link Settings** page
- IODD files loaded using the *IODD Files* page

There are two methods to save or load configuration files.

- PortVision DX - if necessary, refer to the help system
- Web interface

9.5.1. Saving Configuration Files

Use this procedure to save configuration files for the IO-Link master. Use this feature to back up the IO-Link master or to configure multiple IO-Link masters with the same configuration.

1. Click **Configuration | Load/Save**.
2. If applicable, disable any data that you do not want to backup.
3. Click the **SAVE** button.
4. Click the **Save File** option and click the **OK** button.

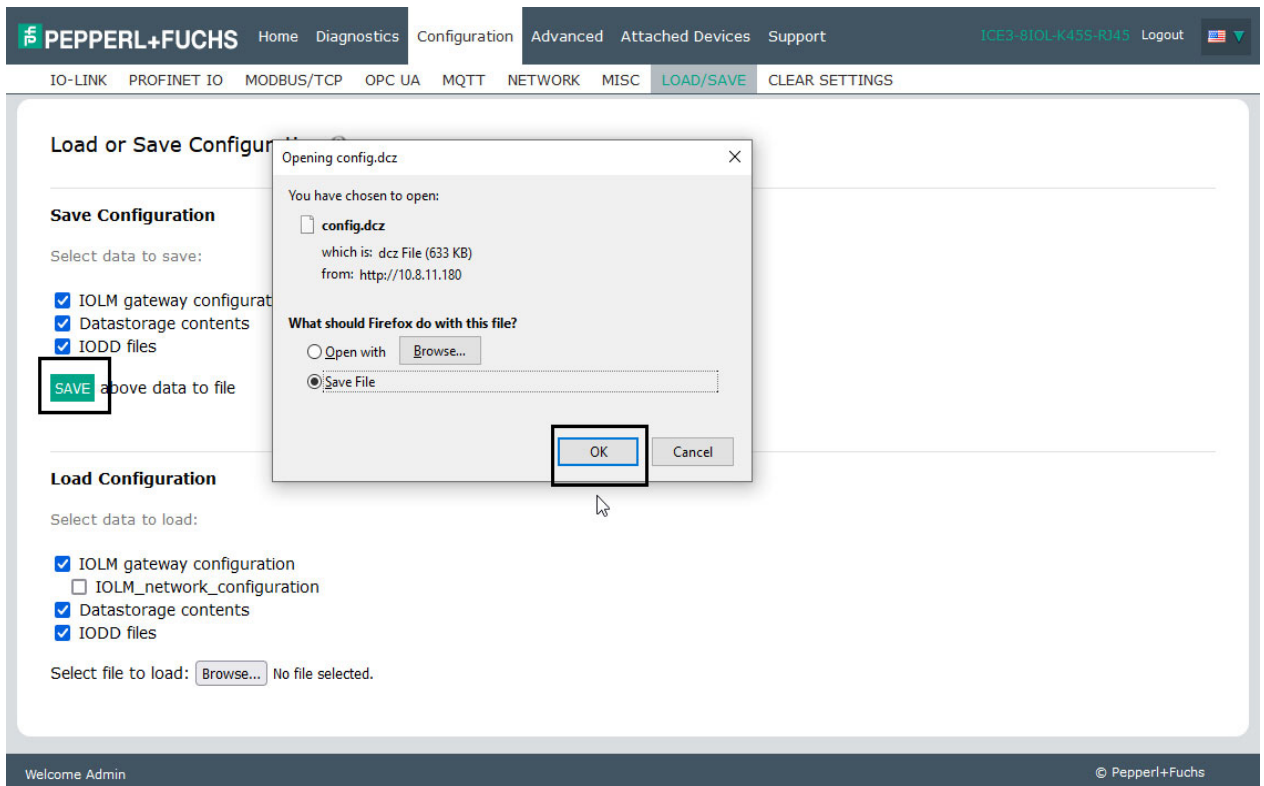

9.5.2. Loading Configuration Files

Use this procedure to load a configuration file onto the IO-Link master.

1. Click **Configuration | Load/Save**.
2. Click the **Browse** button, locate and select the configuration file (**.dcz** extension).
3. Click the **LOAD** button.

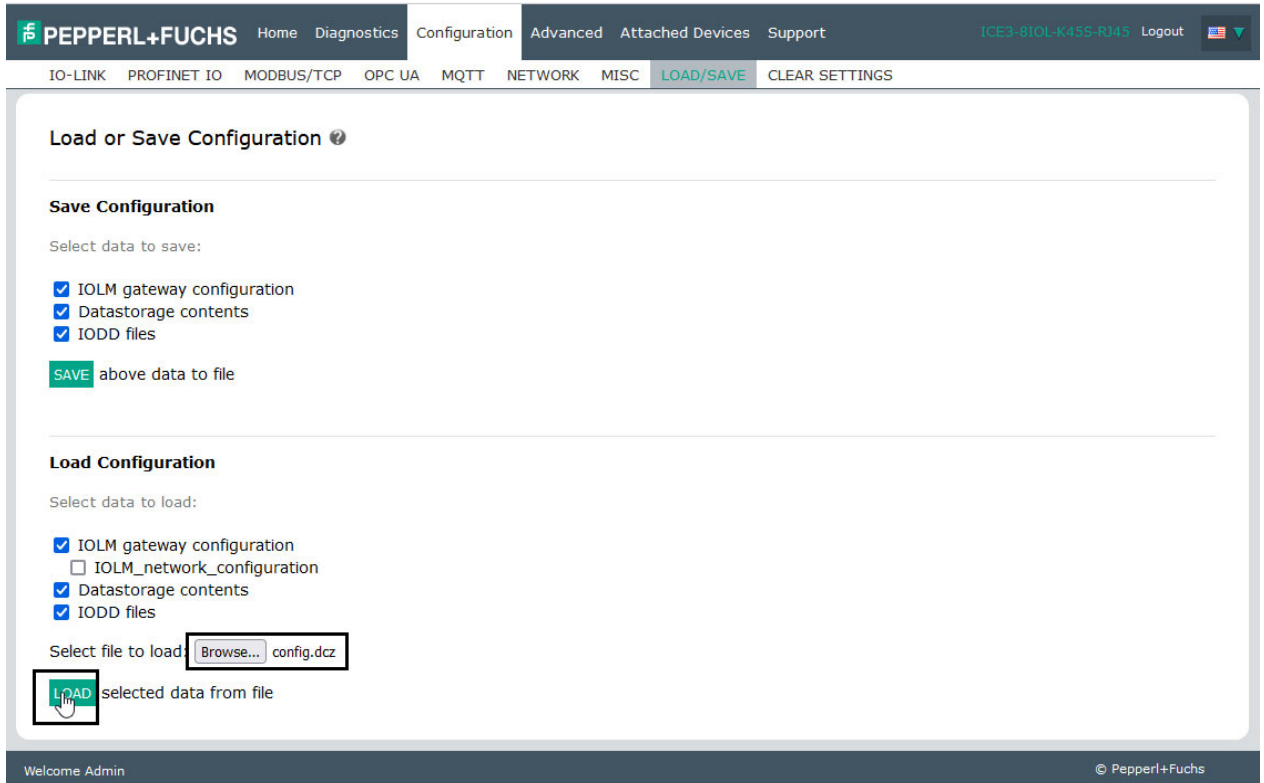

4. Click the **OK** button to close the *Configuration Uploaded* message that notifies you of what configuration parameters loaded.

9.6. Configuring Miscellaneous Settings

The **Miscellaneous Settings** page includes the following options:

- **Menu Bar Hover Shows Submenu**

This option displays sub-menus for a category when you hover over the category name.

For example, if you hover over **Advanced**, the **SOFTWARE**, **ACCOUNTS**, **LOG FILES**, and **LICENSES** sub-menus display. You can click any sub-menu and avoid opening the default menu for a category.

- **Enable PDO Write From Attached Devices Port Page**

When enabled, it allows you to write PDO data to IO-Link slaves from the **Attached Devices I Port** page in the web user interface. See *Enable PDO Write From Attached Devices Port Page* on Page 133 for more information.

Note: *The PDO write will not allow writes if the IO-Link master has a PLC connection. **This should never be enabled in a production environment.***

- **LED Flash**

You can force the IO-Link port LEDs on the IO-Link master into a flashing tracker pattern that allows you to easily identify a particular unit.

- Click the **ON** button to enable the LED tracker feature on the IO-Link master. The LEDs remain flashing until you disable the LED tracker feature
- Click the **OFF** button to disable the LED tracker.

- **IO-Link Test Event Generation**

Use this feature to send events to a port, which can be viewed on the **IO-Link Diagnostics** page.

The screenshot shows the 'Miscellaneous Settings' page in the Pepperl+Fuchs web interface. The navigation bar at the top includes 'PEPPERL+FUCHS', 'Home', 'Diagnostics', 'Configuration', 'Advanced', 'Attached Devices', and 'Support'. The user is logged in as 'ICE3-810L-K48S-R34S' and is viewing the 'MISC' configuration page. The main content area is titled 'Miscellaneous Settings' and contains a table for 'MISC CONFIGURATION' with an 'EDIT' button. The table has two rows: 'Menu Bar Hover Shows Submenu' and 'Enable PDO Write From Attached Devices Port Page', both currently set to 'disable'. Below the table, there are 'LED Flash: 0' controls with 'ON' and 'OFF' buttons. At the bottom, there is a section for 'IO-Link Test Event Generation'. The footer shows 'Welcome Admin' and '© Pepperl+Fuchs'.

9.6.1. Using the Menu Bar Hover Shows Submenu Option

Use this procedure to enable the **Menu Bar Hover Shows Submenu** option. If you enable this feature it displays the sub-menus for a category when you hover over the category name.

For example, if you hover over **Advanced**, the **SOFTWARE**, **ACCOUNTS**, **LOG FILES**, and **LICENSES** sub-menus display. You can click any sub-menu and avoid opening the default menu for a category.

1. Click **Configuration | MISC**.
2. Click the **EDIT** button.
3. Click **Enable** next to the **Menu Bar Hover Shows Submenu** option.
4. Click **SAVE**.

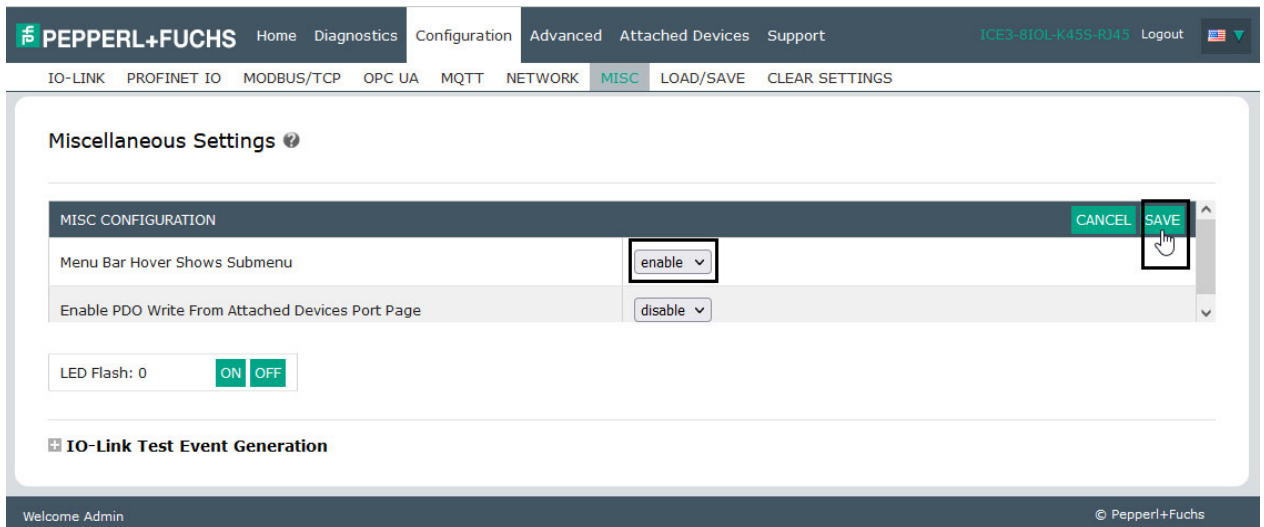

9.6.2. Enable PDO Write From Attached Devices Port Page

The purpose of this feature is for a **non-production** type of demonstration of the IO-Link master. You can enable this feature to get familiar with IO-Link or if you are commissioning a system and want to be able to test / get familiar with devices. It allows you to interact with a PDO device that does not have a PLC connection.

You must have set and signed into the IO-Link master using an **admin** password.

Note: *The PDO write will not allow writes if the IO-Link master has a PLC connection. **This should never be enabled in a production environment.***

Use this procedure to enable PDO write from the **Attached Devices | Port** page.

1. If necessary, log into the IO-Link master using the Administrator account.
2. Click **Configuration | MISC**.
3. Click the **EDIT** button.
4. Click **Enable** next to the **Enable PDO Write From Attached Devices Port Page** option.
5. Click the **SAVE** button.

- If this will not cause an unstable environment, click the **CONTINUE** button.

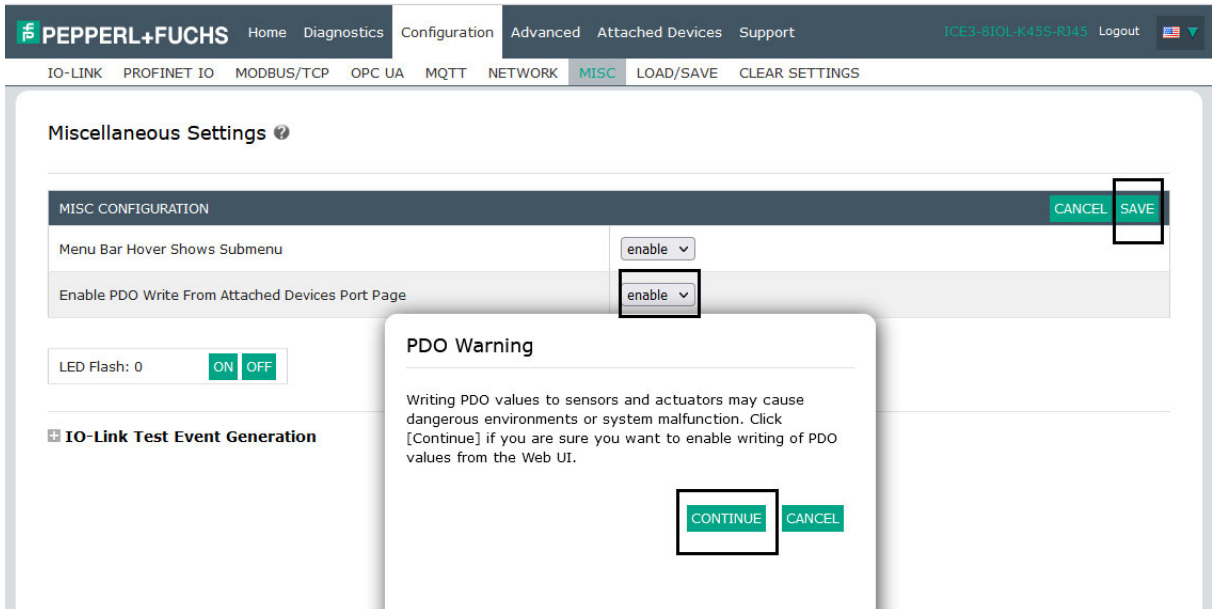

9.6.3. IO-Link Test Event Generator

You can use the **IO-Link Test Event Generator** to send messages to an IO-Link master port. The generated events are displayed in the **Diagnostics | IO-Link Settings** page under the **Last Events** field and the syslog. This can test a port to verify that it is functioning correctly through

- Click **Configuration | Misc**.
- Expand the **IO-Link Test Event Generator**.

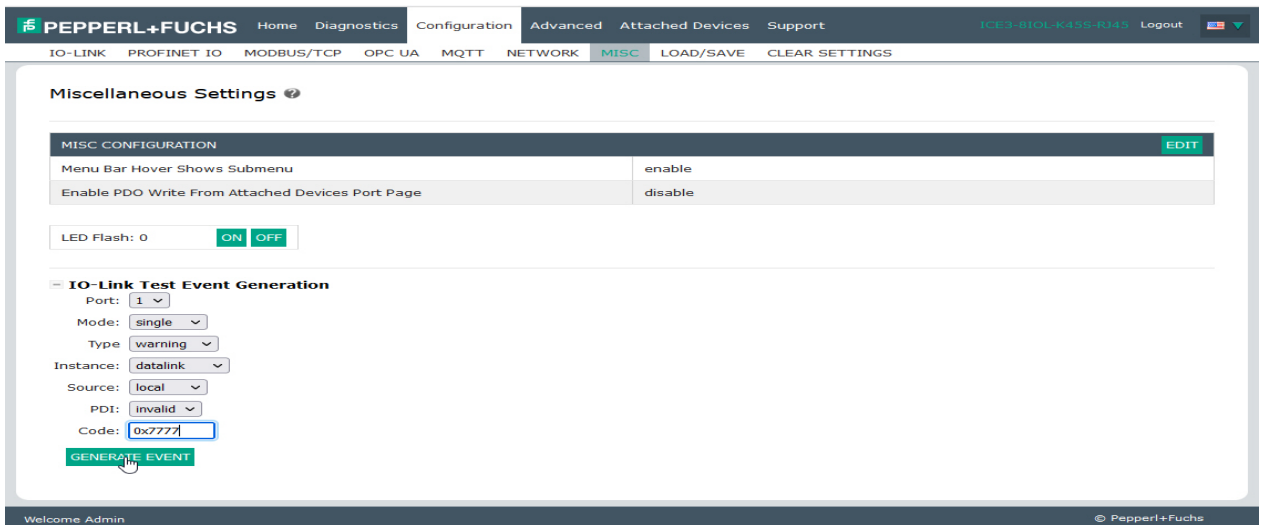

3. Select the port and type of event that you want to test.

IO-Link Test Event Generation

Port: 1

Mode: single

Type: warning

Instance: datalink

Source: local

PDI: invalid

Code: 0x7777

GENERATE EVENT

4. Click **Diagnostics** and scroll down to **Last Events**.

Last Events	
	12)Single,Message,Local,0024h
	m_preoperate
	13)Cleared,Error,Local,0010h
	s_devicelost
	14)Single,Message,Local,0026h
	s_devinfo
	15)Single,Warning,Local,7777h
	unknown

Use the following table to determine what type of event you want to generate.

IO-Link Test Event Generator Descriptions	
Port	The port number to which you want to send an event.
Mode	This is the first item in the event generated. <ul style="list-style-type: none"> Single: generates Single in the event. Coming: generates Active in the event Going: generates Cleared in the event
Type	This is the second item in the event generated. <ul style="list-style-type: none"> Message: generates Message in the event. Warning: generates Warning in the event. Error: generates Error in the event.
Instance	This is the level in which the event is generated. This is not displayed in the generated event. <ul style="list-style-type: none"> unknown physical datalink applayer application
Source	This is the source in which the event is generated. This is the third item in the generated event. <ul style="list-style-type: none"> local: simulation generated from the IO-Link master, which displays as Local in the event. remote: simulation of an IO-Link device event, which displays as Device in the generated event.
PDI	This indicates whether to send valid or invalid PDI, which is not displayed in the generated event. <ul style="list-style-type: none"> valid invalid

IO-Link Test Event Generator Descriptions (Continued)

Code	<p>This is the fourth and fifth items in the generated event.</p> <ul style="list-style-type: none"> • 0x0000: generates a s_pdu_check event • 0x0001: generates a s_pdu_flow event • 0x0002: generates a m_pdu_check event • 0x0003: generates a s_pdu_illegal event • 0x0004: generates a m_pdu_illegal event • 0x0005: generates a s_pdu_buffer event • 0x0006: generates a s_pdu_inkr event • 0x0007: generates an s_pd_len event • 0x0008: generates an s_no_pdin event • 0x0009: generates an s_no_pdout event • 0x000a: generates an s_channel event • 0x000b: generates an m_event event • 0x000c: generates an a_message event • 0x000d: generates an a_warning event • 0x000e: generates an a_device event • 0x000f: generates an a_parameter event • 0x0010: generates a devicelost event • 0x0011, 13 - 17: generates an unknown event • 0x0012: generates a s_desina event
------	--

9.7. Clearing Settings

You can return the IO-Link master to factory default values and can choose whether you want to restore these default values:

- Uploaded IODD files
- IO-Link data storage
- Hostname, network settings (DHCP/Static, static IP address, static network mask, and static IP gateway)

Use the following procedure to restore factory default values on the IO-Link master.

1. Click **Configuration | Clear Settings**.
2. Select the settings that you want to clear.

PEPPERL+FUCHS Home Diagnostics Configuration Advanced Attached Devices Support ICE3-BIOL-K455-R045 Logout

IO-LINK PROFINET IO MODBUS/TCP OPC UA MQTT NETWORK MISC LOAD/SAVE CLEAR SETTINGS

Clear Configuration Settings

The button below will clear configuration values back to factory default values. By default, it will affect all configuration values except for the unchecked categories listed below. To include one or more of those categories check the corresponding box:

- Uploaded IODD files
- IO-Link data storage
- Hostname, DHCP/Static, Static IP address, Static IP network mask, Static IP gateway

CLEAR CONFIGURATION

Welcome Admin © Pepperl+Fuchs

3. Click the **OK** button to the *Done Configuration Cleared* message.

10. Using the Diagnostics Pages

This chapter provides information about the following **Diagnostics** pages.

- *IO-Link Port Diagnostics* on Page 138
- *PROFINET IO Diagnostics Page* on Page 142
- *Modbus/TCP Diagnostics* on Page 146
- *OPC UA Diagnostics Page* on Page 149 (not supported on all models, contact your Pepperl+Fuchs representative for more information)
- *MQTT Diagnostics Page* on Page 150 (not supported on all models, contact your Pepperl+Fuchs representative for more information)
- *Power Diagnostics Page (ICE3-8IOL1-G65L-V1D Only)* on Page 152

10.1. IO-Link Port Diagnostics

Use the **IO-Link Diagnostics** page to determine the status of the IO-Link configuration.

Note: This does not illustrate the complete IO-Link Diagnostic page.

The screenshot shows the 'IO-Link Diagnostics' page in a web browser. The page has a navigation bar with 'Home', 'Diagnostics', 'Configuration', 'Advanced', 'Attached Devices', and 'Support'. The 'Diagnostics' section is active, with sub-tabs for 'IO-LINK', 'PROFINET IO', 'MODBUS/TCP', 'OPC UA', and 'MQTT'. The main content area is titled 'IO-Link Diagnostics' and includes buttons for 'UPDATE', 'STOP LIVE UPDATES', and 'RESET STATISTICS'. Below these is a table comparing the status of two IO-Link ports, PORT 1 and PORT 4. The table lists various parameters such as Port Name, Port Mode, Port Status, IOLink State, Device Vendor Name, Device Product Name, Device Serial Number, Device Hardware Version, Device Firmware Version, Device IO-Link Version, Actual Cycle Time, Device Minimum Cycle Time, Configured Minimum Cycle Time, Data Storage Capable, Automatic Data Storage Configuration, Auxiliary Input Status, Device PDI Data Length, PDI Data Valid, Last Rx PDI Data (MS Byte First), and PDO Lock Enable.

IO-LINK PORT STATUS	PORT 1	PORT 4
Port Name	IO-Link Port 1	IO-Link Port 4
Port Mode	IOLink	IOLink
Port Status	Operational, PDI Valid	Operational, PDI Valid
IOLink State	Operate	Operate
Device Vendor Name	Pepperl+Fuchs	Pepperl+Fuchs
Device Product Name	OBT350-R101-2EP-IO-0,3M-V1	UC400-F77-EP-IO-V31
Device Serial Number	40000078776544	40000069832204
Device Hardware Version	HW01.00	HW01.00
Device Firmware Version	FW01.04	FW01.00
Device IO-Link Version	1.1	1.1
Actual Cycle Time	4.0ms	4.0ms
Device Minimum Cycle Time	2.3ms	2.3ms
Configured Minimum Cycle Time	4ms	4ms
Data Storage Capable	Yes	Yes
Automatic Data Storage Configuration	Download	Upload
Auxiliary Input Status	Off	Off
Device PDI Data Length	1	2
PDI Data Valid	Yes	Yes
Last Rx PDI Data (MS Byte First)	00	00 e3
PDO Lock Enable	Yes	Yes

The following table provides information about the **IO-Link Diagnostics** page.

IO-Link Diagnostics Page	
Port Name	This is an optional friendly port name, which can be configured in the Configuration IO-Link page.
Port Mode	Displays the active device mode: <ul style="list-style-type: none"> • Reset = The port is configured to disable all functionality. • IO-Link = The port is configured to IO-Link mode. • Digital In = The port is configured to operate as a digital input. • Digital Out = The port is configured to operate as a digital output.
Port Status	Displays the port status: <ul style="list-style-type: none"> • Inactive = The port is in active state. Typically, this indicates that the device is either not attached or not detected. • Initializing = The port is in the process of initializing. • Operational = The port is operational and, if in IO-Link mode, communications to the IO-Link device have been established. • PDI Valid = The PDI data is now valid. • Fault = The port has detected a fault and is unable to re-establish communications.
IO-Link State	<ul style="list-style-type: none"> • Operate - Port is functioning correctly in IO-Link mode. This may also display during a data storage upload or download. • Init - The port is attempting initialization. • Reset - One of the following conditions exists: <ul style="list-style-type: none"> - The Port Mode configuration is set to Reset. - The Port Mode configuration is set to DigitalIn or DigitalOut. • DS - Wrong Sensor - Hardware failure (IO-Link LED also flashes red) because there is Data Storage on this port, which does not reflect the attached device. • DV - Wrong Sensor - Hardware failure (IO-Link LED also flashes red) because Device Validation is configured for this port and the wrong device is attached. • DS - Wrong Size - Hardware failure (IO-Link LED also flashes red) because the size of the configuration on the device does not match the size of the configuration stored on the port. • Comm Lost - Temporary state after a device is disconnected and before the port is re-initialized. • Pre-operate - Temporary status displayed when the device: <ul style="list-style-type: none"> - Is starting up after connection or power-up. - Uploading or downloading automatic data storage.
Device Vendor Name	Displays the Device Vendor Name as stored in ISDU Index 16.
Device Product Name	Displays the device product name as stored in ISDU Index 18.
Device Serial Number	Displays the device serial number as stored in ISDU Index 21.

IO-Link Diagnostics Page (Continued)	
Device Hardware Version	Displays the device hardware version as stored in ISDU Index 22.
Device Firmware Version	Displays the device firmware version as stored in ISDU Index 23.
Device IO-Link Version	The supported device IO-Link version as stored in ISDU Index 0.
Actual Cycle Time	This is the actual, or current, cycle time of the IO-Link connection to the device.
Device Minimum Cycle Time	This is the minimum, or fastest, cycle time supported by the connected IO-Link device.
Configured Minimum Cycle Time	Configured in the Configuration IO-Link page, this is the minimum cycle time the IO-Link master will allow the port to operate at. The Actual Cycle Time , which is negotiated between the IO-Link master and the device, will be at least as long as the greater of the Configured Minimum Cycle Time and the Device Minimum Cycle Time .
Data Storage Capable	Displays whether the IO-Link device on a port supports the data storage feature. Not all IO-Link devices support the data storage feature.
Automatic Data Storage Configuration	Displays whether a port is configured to automatically upload data from the IO-Link device or download data from the IO-Link master to the IO-Link device. Disabled displays if automatic upload or download are not enabled.
Auxiliary Input Status (IP67 models)	<ul style="list-style-type: none"> • ICE3-8IOL-G65L-V1D (Ports 1-8): The current status of the auxiliary bit as received on the IO-Link port. • ICE3-8IOL1-G65L-V1D: <ul style="list-style-type: none"> - Ports 1-4: No Aux In status. - Ports 5-8: The current status of the auxiliary bit as received on the IO-Link port.
Device PDI Data Length	The supported Device PDI Data Length, in bytes, as stored in ISDU Index 0.
PDI Data Valid	Current status of PDI data as received from the IO-Link device.
Last Rx PDI Data (MS Byte First)	The last Rx PDI data as received from the IO-Link device.
PDO Lock Enable	If enabled on the Configuration IO-Link Settings page, an industrial protocol application (PROFINET IO or Modbus TCP) can lock the write access to the PDO value so that the PDO value cannot be changed by other protocols (including OPC UA or the Web interface). Such a lock is released when the PLC to IO-Link master network link disconnects.
PDO Locked	Indicates whether or not one of the industrial protocol applications has locked the write access to the PDO value.
Device PDO Data Length	The supported Device PDO Data Length, in bytes, as stored in ISDU Index 0.
PDO Data Valid	Status of PDO data being received from controller(s).
Last Tx PDO Data (MS Byte First)	The last Tx PDO data.
Time Since Initialization	The time since the last port initialization.

IO-Link Diagnostics Page (Continued)	
Process Data Errors	The number of process data errors the port received.
Process Data Retries	The number of process data retries the port performed.
Total Events	The total number of events that were received on this port.
First Events	Up to the first, or oldest, three events that were received on this port.
Last Events	Up to the last, or most recent, three events that were received on this port.
ISDU Statistics	
ISDU Read Cmd Attempts	The number of read ISDU command attempts.
ISDU Read Cmd Errors	The number of read ISDU command errors.
ISDU Write Cmd Attempts	The number of write ISDU command attempts.
ISDU Write Cmd Errors	The number of write ISDU command errors.

10.2. PROFINET IO Diagnostics Page

The **PROFINET IO Diagnostics** page may be useful when trying to troubleshoot communications or port issues related to PROFINET IO configuration.

Note: The complete PROFINET IO Diagnostics page is not illustrated.

The screenshot displays the 'PROFINET IO Diagnostics' page. At the top, there is a navigation bar with the Pepperl+Fuchs logo and menu items: Home, Diagnostics, Configuration, Advanced, Attached Devices, and Support. On the right, it shows the device ID 'ICE3-810L-K45S-RJ45', a 'Logout' button, and a language selector. Below the navigation bar, there are tabs for 'IO-LINK', 'PROFINET IO', 'MODBUS/TCP', 'OPC UA', and 'MQTT'. The main content area is titled 'PROFINET IO Diagnostics' and includes three buttons: 'UPDATE', 'STOP LIVE UPDATES', and 'RESET STATISTICS'. A table titled 'PROFINET IO GENERAL STATUS' lists various metrics and their values. At the bottom, there is a 'PROFINET IO PORT STATUS' section with tabs for PORT 1 through PORT 8.

PROFINET IO GENERAL STATUS	
Active Application Relationships	0
Application Relationship 1 Uptime	
Application Relationship 2 Uptime	
Total Application Relationships Established	15
IOL_CALL Function Block Requests	0
IOL_CALL Function Block Errors	0
Configuration Errors	0
System Errors	0
PROFINET IO Frames Transmitted	493625465
PROFINET IO Transmit Errors	0
PROFINET IO Frames Received	624467654
PROFINET IO Receive Errors	0
Record Reads	0
Record Read Errors	0
Digital IO Input Status Changes	0
Digital IO Writes	0
Digital IO Write Errors	0
IP Assignment	Static
Ethernet Port 1 Link Status	100Mbps Full Duplex
Ethernet Port 2 Link Status	100Mbps Full Duplex
First Error String	Port 3: no IO-Link device available
Last Error String	Ethernet Port 1: link down

PROFINET IO PORT STATUS

PORT 1 PORT 2 PORT 3 PORT 4 PORT 5 PORT 6 PORT 7 PORT 8

Welcome Admin © Pepperl+Fuchs

The following table provides information about the **PROFINET IO Diagnostics** page.

PROFINET IO Diagnostics	
Active Application Relationships	Displays the current number of active PROFINET IO connections.
Application Relationship 1 Uptime	The uptime of the first application relationship.
Application Relationship 2 Uptime	The uptime of the second application relationship.
Total Application Relationships Established	The total number of application relationships that have been established since power up.
IOL_CALL Function Block Requests	The total number of IOL_CALL function block requests received.
IOL_CALL Function Block Errors	The number of errors when handling IOC_CALL function block requests.
Configuration Errors	The number of system configuration related errors.
System Errors	Displays the number of system resource errors. These errors indicate a system error on the IO-Link such as operating system errors or full message queues. These errors typically occur when the PLC(s) are sending messages to the IO-Link master faster than the IO-Link master can process them.
PROFINET IO Frames Transmitted	The total number of transmitted PROFINET IO frames.
PROFINET IO Transmit Errors	The number of errors when transmitting PROFINET IO frames.
PROFINET IO Frames Received	The total number of received PROFINET IO frames.
PROFINET IO Receive Errors	The number of errors when receiving PROFINET IO frames.
Record Reads	The total number of record read requests received.
Record Read Errors	The number of errors when handing record read requests.
Digital IO Input Status Changes	The number of times that the status of the all digital I/O pins have changed.
Digital IO Writes	The number of times that the status of the digital output pins have changed.
Digital IO Write Errors	The number of errors when writing to digital output pins.
IP Assignment	The current IP assignment method.
Ethernet Port 1 Link Status	Current link status of Ethernet Port 1.
Ethernet Port 2 Link Status	Current link status of Ethernet Port 2.

PROFINET IO Diagnostics (Continued)	
First Error String	Text description of the first error that occurred.
Last Error String	Text description of the last error that occurred.
<i>PROFINET IO Port Status</i>	
Application Relationship	The application relationship (1 or 2) that the IO-Link port belongs to.
PDI Reads	The number of PDI reads.
PDI Reads Truncated	The number of PDI reads that are truncated due to size.
PDI Read Errors	The number of errors when reading PDI.
PDO Writes	The number of PDI writes.
PDO Write Errors	The number of errors when reading PDO.
SIO Input Status Changes	The number of time the status of C/Q pin has changed when a port is in SIO input mode.
SIO Output Writes	The number of time the status of C/Q pin has changed when a port is in SIO output mode.
SIO Output Write Errors	The number of errors when writing to C/Q pin when a port is in SIO output mode.
Auxiliary Input Status Changes	The number of time the status of auxiliary pin has changed.
Event Reads	The number of IO-Link events.
Event Read Errors	The number of errors when reading IO-Link events.
Get Port Mode Errors	The number of errors when getting IO-Link port mode.
Set Port Mode Errors	The number of errors when setting IO-Link port mode.
ISDU Request Msgs From PLC(s)	Displays the number of ISDU request messages received from the PLC(s) or other controllers. These request messages may contain one or multiple ISDU commands.
ISDU Invalid Requests	Displays the number of ISDU requests received over PROFINET IO with one or more invalid commands.
Valid ISDU Responses From Port	Displays the number of valid ISDU response messages returned from the IO-Link port interface and available to the PLC(s). The response messages contain results to the ISDU command(s) received in the request message.
ISDU Response Timeouts	Displays the number of ISDU requests that did not receive a response within the configured ISDU Response Timeout .
Maximum ISDU Request Msg Response Time	Displays the maximum time period required to process all commands within an ISDU request message. The response is not available until all ISDU command(s) contained in the request have been processed.
Average ISDU Request Msg Response Time	Displays the average time period required to process the ISDU request message(s). The response is not available until all ISDU command(s) contained in the request have been processed.

2022-12

PROFINET IO Diagnostics (Continued)	
Minimum ISDU Request Msg Response Time	Displays the minimum time period required to process all commands within an ISDU request message. The response is not available until all ISDU command(s) contained in the request have been processed.
ISDU Read Commands	Displays the number of ISDU read commands received over PROFINET IO.
ISDU Read Failures	The number of errors when processing ISDU read commands.
ISDU Write Commands	Displays the number of ISDU write commands received over PROFINET IO.
ISDU Write Failures	The number of errors when processing ISDU write commands.
Process Alarms	The number of process alarms sent to PLC.
Return of Submodule Alarms	The number of Return of Submodule alarms sent to PLC.
Channel Diagnostics Alarms Added	The number of channel diagnostics alarms sent to PLC.
Channel Diagnostics Alarms Removed	The number of channel diagnostics alarms removed from PLC.
Alarm Errors	The number errors when handling PROFINET IO alarms.

10.3. Modbus/TCP Diagnostics

The **Modbus/TCP Diagnostics** page may be useful when trying to troubleshoot Modbus/TCP communications or port issues related to Modbus/TCP configuration.

Note: The complete Modbus/TCP Diagnostics page is not illustrated.

The screenshot shows the 'Modbus/TCP Diagnostics' page. At the top, there are navigation tabs: Home, Diagnostics (selected), Configuration, Advanced, Attached Devices, and Support. The user is logged in as 'ICE3-810L-K455-RJ45'.

The main content area is titled 'Modbus/TCP Diagnostics' and includes three buttons: 'UPDATE', 'STOP LIVE UPDATES', and 'RESET STATISTICS'.

MODBUS/TCP GENERAL STATUS

Modbus/TCP Server Enable	enable
Active Connections	0
Messages Received From Masters	0
Responses Sent To Masters	0
Broadcasts Received	0
Invalid Message Length Errors	0
Invalid Message Data Errors	0
Invalid Message Address Errors	0
Unknown Device ID Errors	0
Invalid Protocol Type Errors	0
Unsupported Function Code Errors	0
Configuration Errors	0
No Available Connection Errors	0
System Resource Errors	0
First Error String	No Error Detected
Last Error String	

MODBUS/TCP PORT STATUS

	PORT 1	PORT 2	PORT 3	PORT 4	PORT 5	PORT 6	PORT 7	PORT 8
Active PDO Controller(s)								
PDO Writes to Offline or Read-Only Ports	0	0	0	0	0	0	0	0
ISDU Request Msgs from PLC(s)	0	0	0	0	0	0	0	0
ISDU Invalid Requests	0	0	0	0	0	0	0	0
ISDU Requests When Port Offline	0	0	0	0	0	0	0	0
Valid ISDU Responses from Port	0	0	0	0	0	0	0	0

Footer: Welcome Admin | © Pepperl+Fuchs

The following table provides information about the **Modbus/TCP Diagnostics** page.

Modbus/TCP Diagnostics Page	
Active Connections	Displays the current number of active Modbus/TCP connections.
Messages Received from Masters	Displays the number of Modbus messages received from Modbus/TCP Masters.
Responses Sent to Masters	Displays the number of Modbus responses sent to Modbus/TCP Masters.
Broadcasts Received	Displays the number of broadcast Modbus/TCP messages received.

2022-12

Modbus/TCP Diagnostics Page (Continued)	
Invalid Message Length Errors	Displays the number of Modbus messages received with incorrect length fields.
Invalid Message Address Errors	Displays the number of invalid message address errors. These errors occur when the IO-Link master receives a message that cannot be performed due to an invalid address.
Unknown Device ID Errors	Displays the number of unknown device ID errors. These errors occur when the IO-Link master receives a message that is addressed to a device ID other than the configured Slave Mode Device ID .
Invalid Protocol Type Errors	Displays the number of invalid message protocol type errors. These errors occur when the IO-Link master receives a Modbus/TCP message that specifies a non-Modbus protocol.
Unsupported Function Code Errors	Displays the number of invalid Modbus function code errors. These errors occur when the IO-Link master receives a message that cannot be performed due to an unsupported Modbus function code.
Configuration Errors	Displays the number of improper configuration errors. These errors occur when the IO-Link master receives a message that cannot be performed due to an invalid configuration.
No Available Connection Errors	Displays the number of Modbus/TCP connection attempts that were rejected due to no available connections. This occurs when the number of Modbus/TCP connections has reached the limit.
First Error String	Text description of the first error that occurred.
Last Error String	Text description of the last error that occurred.
Modbus/TCP Port Specific Diagnostics	
Active PDO Controller(s)	Lists IP addresses that are controlling the PDO data.
PDO Writes to Offline or Read-Only Ports	Displays the number of PDO write messages that were dropped due to any of the following: <ul style="list-style-type: none"> • The port is configured in IO-Link mode: <ul style="list-style-type: none"> - There is no device connected to the port. - The IO-Link device is off-line. - The IO-Link device does not support PDO data. • The PDO Transmit Mode (To PLC) is disabled. • The port is configured in Digital Input mode.
ISDU Request Msgs From PLC(s)	Displays the number of ISDU request messages received from the PLC(s) or other controllers. These request messages may contain one or multiple ISDU commands.
ISDU Invalid Requests	Displays the number of ISDU requests received over Modbus/TCP with one or more invalid commands.

Modbus/TCP Diagnostics Page (Continued)	
ISDU Requests When Port Offline	<p>Displays the number of ISDU requests received over Modbus/TCP when the IO-Link port was offline. This can occur when:</p> <ul style="list-style-type: none"> • The IO-Link port is initializing, such as after start-up. • There is no IO-Link device attached to the port. • The IO-Link device is not responding. • Communication to the IO-Link device has been lost.
Valid ISDU Responses From Port	Displays the number of valid ISDU response messages returned from the IO-Link port interface and available to the PLC(s). The response messages contain results to the ISDU command(s) received in the request message.
Maximum ISDU Request Msg Response Time	The maximum time period required to process all commands within an ISDU request message. The response is not available until all ISDU command(s) contained in the request have been processed.
Average ISDU Request Msg Response Time	The average time period required to process the ISDU request message(s). The response is not available until all ISDU command(s) contained in the request have been processed.
Minimum ISDU Request Msg Response Time	The minimum time period required to process all commands within an ISDU request message. The response is not available until all ISDU command(s) contained in the request have been processed.
ISDU Read Commands	Displays the number of ISDU read commands received over Modbus/TCP.
ISDU Write Commands	Displays the number of ISDU write commands received over Modbus/TCP.
ISDU NOP Commands	Displays the number of ISDU NOP (no operation) commands received over Modbus/TCP.



10.4. OPC UA Diagnostics Page

The **OPC UA Diagnostics** page displays status for OPC UA:

- Whether the OPC UA feature is enabled or disabled
- Number of TCP connections

Note: You can refer to *OPC UA Supporting Information on Page 197*.

The screenshot shows the web interface for the OPC UA Diagnostics page. At the top, there is a navigation bar with the Pepperl+Fuchs logo and menu items: Home, Diagnostics, Configuration, Advanced, Attached Devices, and Support. The user is logged in as 'ICE3-8101-R455-R345' and can click 'Logout'. Below the navigation bar, there are tabs for 'IO-LINK', 'PROFINET IO', 'MODBUS/TCP', 'OPC UA' (which is selected), and 'MQTT'. The main content area is titled 'OPC UA Diagnostics' and contains a table under the heading 'OPC UA GENERAL STATUS'. The table has two rows: 'OPC UA Server Enable' with a value of 'enable', and 'Number of TCP connections' with a value of '0'. To the right of the table are three buttons: 'UPDATE', 'STOP LIVE UPDATES', and 'RESET STATISTICS'. At the bottom of the page, there is a footer with 'Welcome Admin' on the left and '© Pepperl+Fuchs' on the right.

OPC UA GENERAL STATUS	
OPC UA Server Enable	enable
Number of TCP connections	0

10.5. MQTT Diagnostics Page

The *MQTT Diagnostics* page provides the following information.

Note: Refer to *MQTT Supporting Information on Page 204* for more detailed information about MQTT.

Note: By default, MQTT is disabled. Use the *MQTT Configuration* page to configure MQTT settings.

MQTT General Status Diagnostics Page	
MQTT Client Enable	Displays whether the MQTT client has been enabled or disabled.
MQTT Client State	Displays connection status: <ul style="list-style-type: none"> Connected Disconnected
Connect Successes	The number of successful attempts to connect to the MQTT broker.
Connect Failures	The number of failed attempts to connect to the MQTT broker.
Connections Lost	The number of connections to the MQTT broker than have been lost.
Last Connection Error	Displays the last type of connection error.
Publish Attempts	The number of attempts to publish a data message to an MQTT topic.
Publish Successes	The number of successfully published MQTT data messages.
Publish Failures	The number of failed attempts to publish an MQTT data message.
Last Publish Error	Displays the last publish error.

2022-12



MQTT General Status Diagnostics Page	
Subscribe Attempts	The number of attempts to subscribe to an MQTT topic.
Subscribe Successes	The number of successful attempts to subscribe to an MQTT topic.
Subscribe Failures	The number of failed attempts to subscribe to an MQTT topic.
Last Subscribe Error	The last error that occurred when attempting to subscribe to an MQTT topic.
Subscribed Messages Received	The number of MQTT data messages received on subscribed topics.

10.6. Power Diagnostics Page (ICE3-8IOL1-G65L-V1D Only)

The *Power Diagnostics* page displays status of power related information for the ICE3-8IOL1-G65L-V1D.

POWER GENERAL STATUS

UA Power Supply Status	On
Input Power FETs Temperature	33.4°C
RPP FET Temperature	33.9°C
FPGA/Processor Temperature	36.9°C
Class B Quad High Side Temperature	34.1°C
Class A Quad High Side Temperature	35.0°C

POWER PORT STATUS

	PORT 1	PORT 2	PORT 3	PORT 4	PORT 5	PORT 6	PORT 7	PORT 8
Port Class	Class B	Class B	Class B	Class B	Class A	Class A	Class A	Class A
2L+ Status	On	Off	Off	On				
2L+ Faults	0	0	0	0				
Auxiliary Output Status					Off	Off	Off	Off
Auxiliary Output Faults					0	0	0	0
L+ Status	On	On	On	On	On	On	On	On
L+ Overcurrent	No	No	No	No	No	No	No	No
L+ Undervoltage	No	No	No	No	No	No	No	No
CQ Driver Fault	No	No	No	No	No	No	No	No
Thermal Shutdown	No	No	No	No	No	No	No	No
Die Temperature Warning	No	No	No	No	No	No	No	No
VCC Undervoltage	No	No	No	No	No	No	No	No
VCC Supply Voltage Warning	No	No	No	No	No	No	No	No

ICE3-8IOL1-G65L-V1D Power Diagnostics	
POWER GENERAL STATUS	
UA Power Supply Status	Displays the U_A power status, which is required to meet Class B power standards.
Input Power FETs Temperature	Displays the current temperature of input power FETs.
RPP FET Temperature	Displays the current temperature of RPP FET.
FPGA/Processor Temperature	Displays the current temperature of FPGA and processor.
Class B Quad High Side Temperature	Displays the current temperature of Class B quad high side drivers.
Class A Quad High Side Temperature	Displays the current temperature of Class A quad high side drivers.
POWER PORT STATUS	
Port Class	IO-Link port Class A or Class B.

2022-12

ICE3-8IOL1-G65L-V1D Power Diagnostics (Continued)	
2L+ Status	Displays the current status of 2L+ power supply. Class B ports only.
2L+ Faults	Displays the total number of faults on 2L+ power supply. Class B ports only.
Auxiliary Output Status	Displays the current auxiliary digital output status. Class A ports only.
Auxiliary Output Faults	Displays the total number of faults on auxiliary digital output. Class A ports only.
L+ Status	Displays the current status of L+ power supply.
L+ Overcurrent	Displays if L+ power supply load current exceeds the current-limit threshold.
L+ Undervoltage	Displays if L+ power supply falls below 18V.
CQ Driver Fault	Displays if a fault is detected on the CQ driver.
Thermal Shutdown	Displays if the die temperature reaches 150 ° C and the die enters thermal shutdown.
Die Temperature Warning	Displays if the die temperature reaches 135 ° C warning threshold.
VCC Undervoltage	Displays if the Vcc voltage falls below 9V.
VCC Supply Voltage Warning	Displays if the Vcc voltage falls below 18V.

11. PROFINET IO Reference Information

11.1. Sample IO-Link master Gateway Configuration

This section demonstrates how to configure and use an IO-Link gateway.

Slot	Module	Order number	I Address	Q address	Diagnostic Address	Comment	Access
0	YN115CPN8RPIO	YN115CPN8RPIO			2031*		Full
X1	Interface				2030*		Full
X1 P1	Port 1				2029*		Full
X1 P2	Port 2				2028*		Full
1	IO-Link In 2 bytes		6..7				Full
2	IO-Link In/Out 2 bytes		8..9	2..3			Full
3	SIO Digital In		10				Full
4	SIO Digital Out			4			Full
5							
6							
7							
8							
9							
10	IO-Link Status		1..4				Full

STEP 7 V5.5 Pepperl+Fuchs gateway Configuration Example

Device overview							
Module	...	Rack	Slot	I address	Q address	Type	
▼ YN115CPN8RPIO		0	0			YN115CPN8RPIO	
▶ Interface		0	0 X1			YN115CPN8RPIO	
IO-Link In 2 bytes_1		0	1	6...7		IO-Link In 2 bytes	
IO-Link In/Out 2 bytes_1		0	2	8...9	2...3	IO-Link In/Out 2 bytes	
SIO Digital In_1		0	3	10		SIO Digital In	
SIO Digital Out_1		0	4		4	SIO Digital Out	
		0	5				
		0	6				
		0	7				
		0	8				
		0	9				
IO-Link Status_1		0	10	1...4		IO-Link Status	

TIA Portal V13 - Pepperl+Fuchs gateway Configuration Example

- The first IO-Link device, which supported 2 bytes of PDI data, was connected to IO-Link Port 1. The PDI data were mapped into the process image at address IW 6 of the IO controller, as shown in the figure above. The IO controller could read the current PDI data from the IO-Link device at IW 6.
- The second IO-Link device, which supported 2 bytes of PDI data and 2 bytes of PDO data, was connected to IO-Link Port 2. The PDI data were mapped into the process image at address IW 8. The PDO data were mapped into process image at address QW 2. The IO controller could access PDI and PDO via the two memory locations.

2022-12

- IO-Link Port 3 and Port 4 were configured as SIO Digital In and SIO Digital Out. The IO controller could read the input status of the C/Q pin of Port 3 at IB 10, and set the output C/Q pin value of Port 4 by writing to QB 4. IO-Link port status was reported through the module in Slot 10. The 4-byte port status was available at IB 1 to IB 4.
- A Digital I/O module was plugged in Slot 9. DIO 2 and 4 were configured as digital outputs. The IO controller could reads digital input status at IB 5 and set digital output at QB 1.

Using a variable table, as shown in the following, we monitored and modified the IO data directly.

		Address	Symbol	Display format	Status value	Modify value
1		IB 1	"Status_Active"	BIN	2#0000_1111	
2		IB 2	"Status_PDInvalid"	BIN	2#0000_1111	
3		IB 3	"Status_AuxiliaryInput"	BIN	2#0011_1101	
4		IB 4	"Status_Error"	BIN	2#0000_0000	
5		IW 6	"P1_IOLinkIn2bytes"	HEX	W#16#07B9	
6		IW 8	"P2_IOLinkIn2bytes"	HEX	W#16#0000	
7		IB 10	"P3_SIOInput"	HEX	B#16#01	
8		QB 4	"P4_SIOOutput"	HEX	B#16#01	B#16#01
9		IB 5	"DIO_Input"	BIN	2#0000_0000	
10		QB 1	"DIO_Output"	BIN	2#0000_1010	2#0000_1010

STEP 7 V5.5 - Monitoring and Modifying IO Data

	i	Name	Address	Display form..	Monitor value	Modify value
1		"Status_Active"	%IB1	Bin	2#0000_1111	
2		"Status_PDInvalid"	%IB2	Bin	2#0000_1111	
3		"Status_AuxiliaryInput"	%IB3	Bin	2#0000_1101	
4		"Status_Error"	%IB4	Bin	2#0000_0000	
5		"P1_IOLinkIn2bytes"	%IW6	Hex	16#07B0	
6		"P2_IOLinkIn2bytes"	%IW8	Hex	16#0000	
7		"P2_IOLinkOut2bytes"	%QW2	Hex	16#0000	
8		"P3_SIOInput"	%IB10	Hex	16#01	
9		"P4_SIOOutput"	%QB4	Hex	16#01	16#01
10		"DIO_Input"	%IB5	Bin	2#0000_1111	
11		"DIO_Output"	%QB1	Bin	2#0000_1010	2#0000_1010

TIA Portal V13 - Monitoring and Modifying IO Data

IB 1-4 were input data from **IO-Link Status** module (Slot 10). IB 1 was IO-Link Active, IB 2 was PDI Valid, IB 3 was Auxiliary Input, and IB 4 was IO-Link Error. According to the current value of IB 1, Ports 1-4 were active. IB 2 showed the PDI data of Ports 1-4 were valid. IB 3 showed that the auxiliary input pins of Ports 1, 3, and 4 were high. No errors were detected so IB 4 was zero.

The PDI data of Port 1 was shown in IW 6. The PDI data of Port 2 was shown in IW 8.

In this example, we connected the C/Q pin, auxiliary input pin of Port 3 and Port 4 together, creating a testing loopback. Then we modified QB 4 to 0x01, which turned the C/Q Pin of Port 4 to high. IB 10 showed the status of the C/Q pin of Port 3 was high (0x01) as a result. The high status of auxiliary input pins of Ports 3 and 4 was reflected in IB 3.

To test the digital I/O ports, we created testing loopbacks by connecting DIO 1 to 2, and DIO 3 to 4 with wires. Then we changed QB 1 to 2#0000_1010, which set the DIO 2 and DIO 4 to high. IB 5 showed the input status of DIO 1-4 were high (2#0000_1111).

Slot 5-8 (Port 5-8) and Slot 11 were open. They could be used by another IO controller via a second application relationship.

11.2. Available Record Data

11.2.1. PDI as Record Data

For IO modules that have input data, PDI data can also be read by using the SFB52 **RDREC** (read record). The following table shows the available record read indexes for the IO-Link master.

Index	Description
0..(N-1)	1-N byte of input data from a module that has input data, where N is the module's input data size. For example: <ul style="list-style-type: none"> • Index 0..31 for an IO-Link In/Out 32 bytes module. • Index 0..3 for an IO-Link Status module.

Using the same example in *Sample IO-Link master Gateway Configuration* on Page 154; a record read request of 2-bytes at index 0 to the module at slot 1 would return the current PDI data of the IO-Link device attached to Port 1. A record read request of 1-byte at Index 0 slot 10 would return the current IO-Link port active status.

Reading partial PDI data via record read request is supported. For an instance, an IO-Link device that supports 32-bytes PDI data is connected to IO-Link Port 5. A record read request of 32-bytes at Index 0 returns the whole 32-bytes of PDI data. Another record read request of 4-bytes at Index 28 returns the last 4-bytes of the PDI data. This provides flexibility in being able to get only the interested data from a large PDI data block.

The IO-Link master returns an error if a record read request contains an invalid index, such as index is out of the range of module's input data.

11.2.2. IO-Link Device Information as Record Data

When an IO-Link device is connected, IO-Link Master automatically sends ISDU requests to the device to collect common device information. This information, called IO-Link Device Information is available as a record data at index 1000 of the IO-Link module. The following table shows the structure of the IO-Link Device Information structure. All Integer fields are in big-endian format.

Offset	Bytes	Type	Description
0	4	32-bit Integer	Device ID
4	4	32-bit Integer	Vendor ID
8	4	32-bit Integer	Function ID
12	4	32-bit Integer	Minimum IO-Link cycle time (us)
16	4	32-bit Integer	Actual IO-Link cycle time (us)
20	4	32-bit Integer	PDI Data Length (bytes)
24	4	32-bit Integer	PDO Data Length (bytes)
28	4	32-bit Integer	ISDU Capable
32	4	32-bit Integer	Data Storage Capable
36	4	32-bit Integer	Data Storage Length
40	2	16-bit Integer	IO-Link Version
42	16	String	Page 1
58	16	String	Page 2
74	80	String	Vendor name

Offset	Bytes	Type	Description
154	80	String	Vendor text
234	80	String	Product name
314	80	String	Product ID
394	80	String	Product text
474	32	String	Serial number
506	80	String	Hardware version
586	80	String	Firmware version
666	64	String	Application tag
730	64	String	Function tag
794	64	String	Location tag

Note: To read the IO-Link Device Information, the target area of read instruction must be big enough to hold the entire device information (858 bytes).

Not all fields are supported by all IO-Link devices. The unsupported fields will be filled with zeros.

11.2.3. Using the SFB52 RDREC

To use the SFB52 **RDREC**, specify the index of the requested module in **INDEX**. Specify the maximum number of bytes you want to read in **MLEN**. The selected length of the target area **RECORD** should have at least the length of **MLEN** bytes.

TRUE on output parameter **VALID** verifies that the data record has been successfully transferred into the target area **RECORD**. In this case, the output parameter **LEN** contains the length of the fetched data in bytes.

The output parameter **ERROR** indicates if a data record transmission error has occurred. In this case, the output parameter **STATUS** contains the error information.

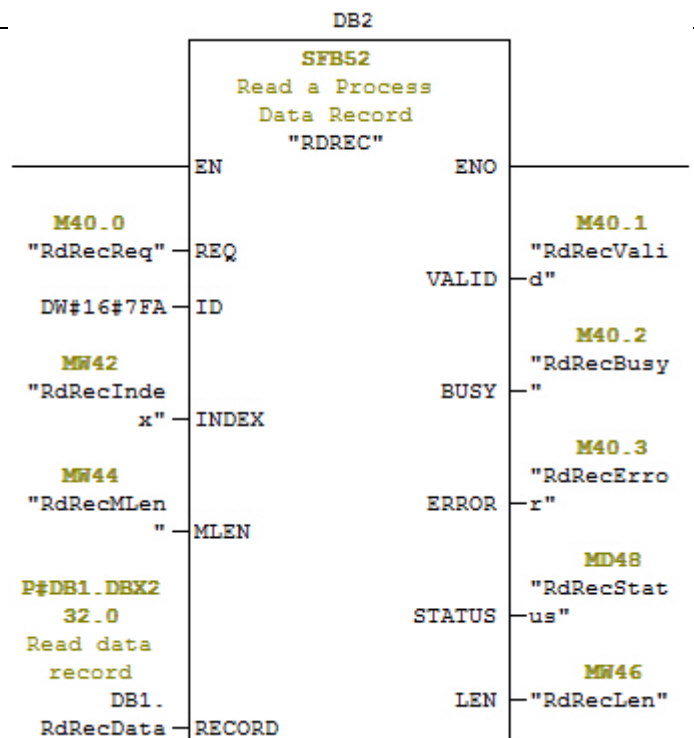

SFB52 Read a Process Data Record

11.3. Read and Write ISDU with the FB IOL_CALL

The function block **IOL_CALL** represents the conversion of the communication standardized for the IO-Link technology to and from IO-Link devices. The IO-Link master supports the **IOL_CALL** function block. It can be used to access an ISDU of an IO-Link device.

The **IOL_CALL** function block and the library description are available at <http://support.automation.siemens.com/WW/view/en/82981502>.

To use **IOL_CALL** function block, do the following:

1. Set **CAP** to 255.
2. Specify **PORT** to be the IO-Link port number (1 to 8) at which the IO-Link device is connected.
3. Set **IOL_INDEX** and **IOL_SUBINDEX** to be the index and subindex of the requested ISDU. **RECORD_IOL_DATA** requires the full specification of the DB parameters, i.e. **P#DB1.DBX0.0** byte 232.
The target area **RECORD_IOL_DATA** must have enough available bytes to hold the requested ISDU block up to 232 bytes.
4. Set **RD_WR** to 0 for read and 1 for write. For write, also specify the length of the data to be written in **LEN**. A positive edge on **REQ** starts the **IOL_CALL** request.

BUSY is set to 1 when the **IOL_CALL** request is in progress. Once completed, **DONE_VALID** is set to 1 if there was no error. Otherwise, **ERROR** is set and **STATUS** and **IOL_STATUS** contain the error information. For the remainder of the **IOL_CALL** function block parameters and complete error information, refer to the **IOL_CALL** library description.

Parameter	Description
CAP	Access point of the IOL_CALL function. Use 255.
PORT	IO-Link port number at which the IO-Link device is operated, port number 1 through 8. All other values: not supported.
IOL_INDEX	Address parameter INDEX (IO-Link device). 0 - 32767: index of ISDU
IOL_SUBINDEX	Address parameter SUBINDEX (IO-Link device). <ul style="list-style-type: none"> 0: not support 1 - 255: subindex of ISDU

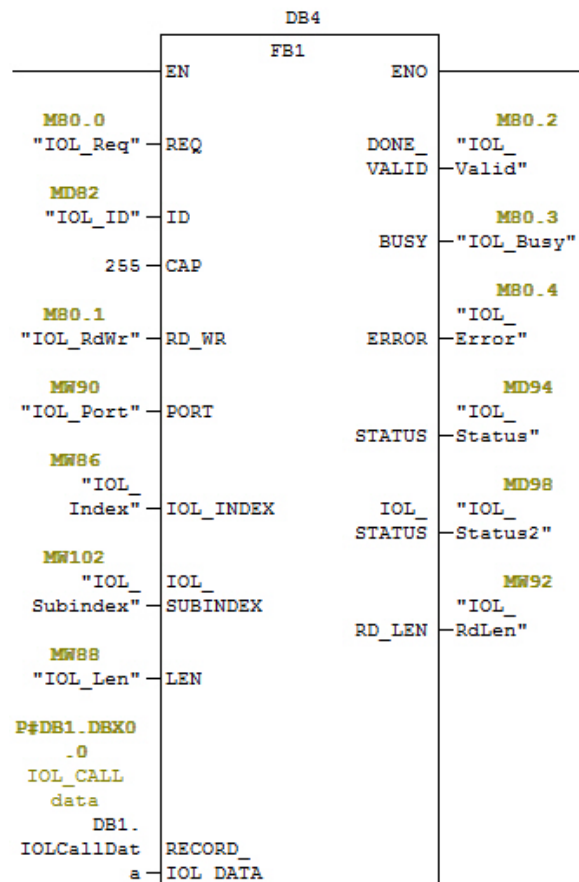

IOL_CALL Function Block

The **IOL_CALL** function block has a 20 seconds timeout value. If the request takes longer than 20 seconds, the process is aborted and a timeout error is returned. The IO-Link master also has a timeout value for **IOL_CALL** request. The default timeout value is 20 seconds. It can be changed through the web page (**Configuration | PROFINET IO**).

11.3.1. Using the IO-Link Library In the TIA Portal

Use the following procedure to use the IO-Link library in the TIA Portal.

1. Download the IO-Link library from Siemens: <http://support.automation.siemens.com/WW/view/en/82981502>.
 For TIA Portal V13, download the **Archive_IO_LINK_CALL.zip** archive.
 For STEP 7 V5.5 and V14, download **82981502_IO_LINK_Library_V3.1**.
2. Unzip the library to a working directory.
3. Configure the TIA Portal project.
 - a. Create a new or open an existing TIA Portal project.
 - b. Configure the PLC, Pepper+Fuchs gateway and all the IO-Link ports.
 - c. Compile and download the project.
 - d. Make sure that everything is working as expected.
4. Take a note of the hardware identifier of the IO-Link module, which will be used to access IO-Link device ISDU.

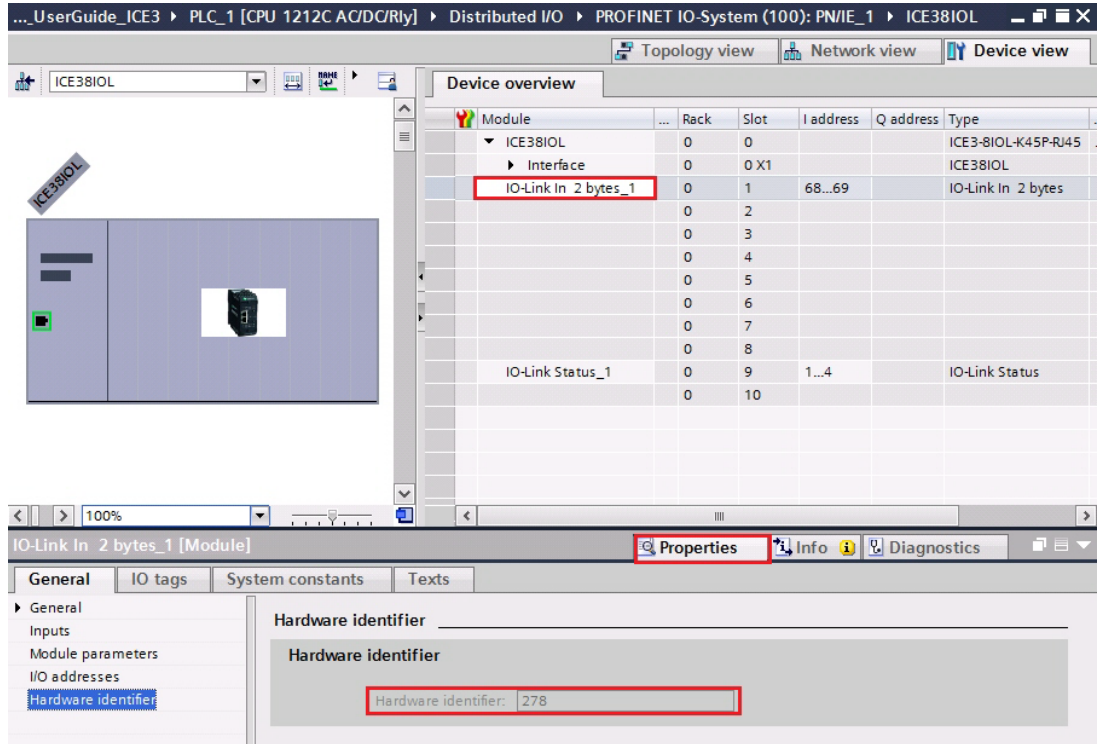

5. Open the IO-Link library.
 - a. In TIA Portal, click the **Open global library** button on the **Libraries** tab.
 - b. Navigate to the above working directory, where the IO-Link library was unzipped.
 - c. Select the **IO_LINK_V13.a113** and click **Open**. Depending on the version of TIA Portal, the library may need to be upgraded.

- d. After opened, there should be an **82981502_IO_LINK_XXX** library. **IO_LINK_CALL_1200 V 2.2.0** is the one that will be used.

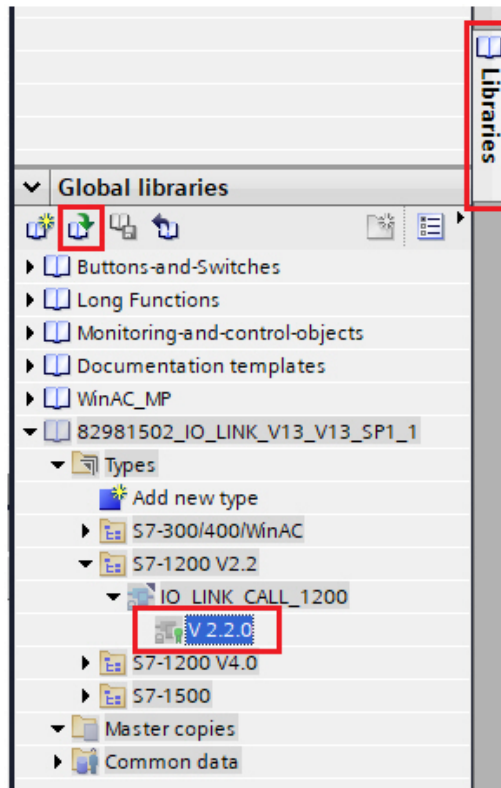

6. Create tags and data block by going to **PLC tags**, create some tags that will be used as the parameters of **IO_LINK_CALL**.

IO_Link_Library_Demo > PLC_1 [CPU 1212C AC/DC/Rly] > PLC tags > Default tag table [38]

Default tag table							
	Name	Data type	Address	Retain	Visibl...	Acces...	Comment
1	Req	Bool	%M0.0	<input type="checkbox"/>	<input checked="" type="checkbox"/>	<input checked="" type="checkbox"/>	
2	ID	Hw_Io	%MW2	<input type="checkbox"/>	<input checked="" type="checkbox"/>	<input checked="" type="checkbox"/>	
3	RdWr	Bool	%M0.1	<input type="checkbox"/>	<input checked="" type="checkbox"/>	<input checked="" type="checkbox"/>	
4	IOLPort	UInt	%MW4	<input type="checkbox"/>	<input checked="" type="checkbox"/>	<input checked="" type="checkbox"/>	
5	IOLIndex	UInt	%MW6	<input type="checkbox"/>	<input checked="" type="checkbox"/>	<input checked="" type="checkbox"/>	
6	IOLSubindex	UInt	%MW8	<input type="checkbox"/>	<input checked="" type="checkbox"/>	<input checked="" type="checkbox"/>	
7	Len	UInt	%MW10	<input type="checkbox"/>	<input checked="" type="checkbox"/>	<input checked="" type="checkbox"/>	
8	DoneValid	Bool	%M0.2	<input type="checkbox"/>	<input checked="" type="checkbox"/>	<input checked="" type="checkbox"/>	
9	Busy	Bool	%M0.3	<input type="checkbox"/>	<input checked="" type="checkbox"/>	<input checked="" type="checkbox"/>	
10	Error	Bool	%M0.4	<input type="checkbox"/>	<input checked="" type="checkbox"/>	<input checked="" type="checkbox"/>	
11	Status	DWord	%MD12	<input type="checkbox"/>	<input checked="" type="checkbox"/>	<input checked="" type="checkbox"/>	
12	IOLStatus	DWord	%MD16	<input type="checkbox"/>	<input checked="" type="checkbox"/>	<input checked="" type="checkbox"/>	
13	RdLen	UInt	%MW20	<input type="checkbox"/>	<input checked="" type="checkbox"/>	<input checked="" type="checkbox"/>	

7. Add a new data block and create a 232-byte array, which will be used to store the ISDU data.

	Name	Data type	Start value	Retain	Accessible f...	Visible in .
1	Static			<input type="checkbox"/>	<input type="checkbox"/>	<input type="checkbox"/>
2	IOLData	Array[0..231] of Byte		<input type="checkbox"/>	<input checked="" type="checkbox"/>	<input checked="" type="checkbox"/>

8. Insert **IO_LINK_CALL**.
 - a. Open the **Main** block.
 - b. From the Global libraries, select **82981502_IO_LINK_xxx | Types | S7-1200V2.2 | IO_LINK_CALL_1200 | V2.2.0** and insert it into a new network.
 - c. Enter the parameters using the above tags. Enter **255** for the parameter CAP.
 - d. Compile and download the project.

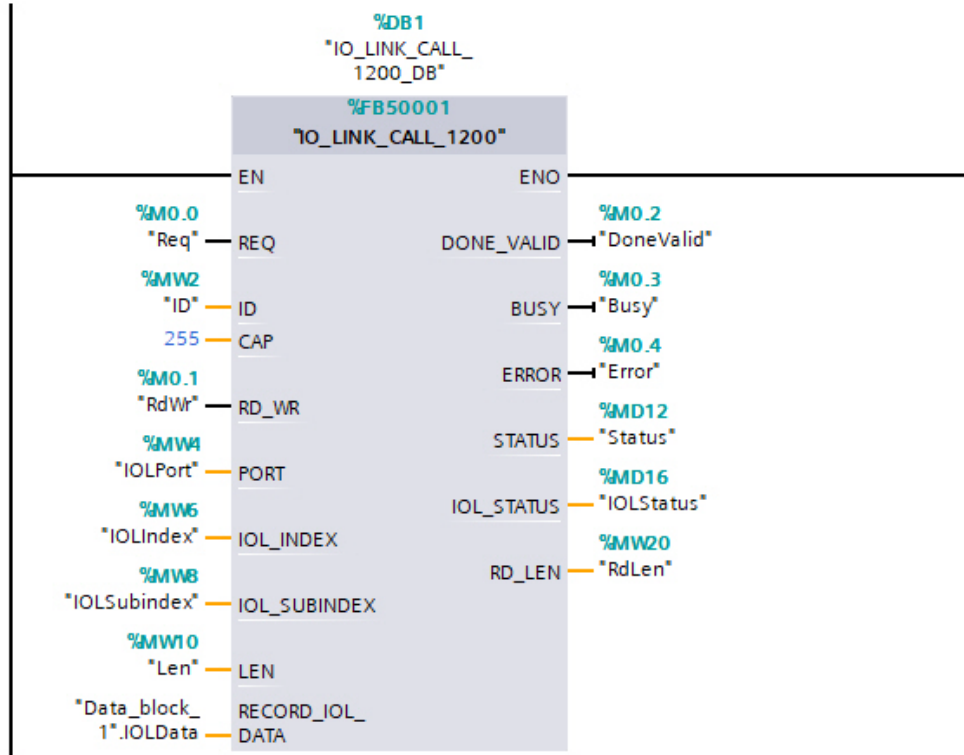

9. Test **IO_LINK_CALL**.
 - a. Create a new watch table and enter the parameters of **IO_LINK_CALL**.
 - b. Click the **Monitor all** button to start monitoring all tags.
 - c. Enter the hardware identifier of the IO-Link module as the modify value of tag ID.
 - d. Enter the IO-Link port number (1 based), index, subindex, and length of the requested ISDU as the modify value of the corresponding tags.

- e. Finally set the **Req** tag to be true and click the **Modify once** button.

IO_Link_Library_Demo ▶ PLC_1 [CPU 1212C AC/DC/Rly] ▶ Watch and force tables ▶ Watch table_1

	Name	Address	Display format	Monitor value	Modify value	
1	*Req*	%MO.0	Bool	<input checked="" type="checkbox"/> TRUE	TRUE	<input checked="" type="checkbox"/> ⚠
2	*ID*	%MW2	DEC	278	278	<input checked="" type="checkbox"/> ⚠
3	*RdWr*	%MO.1	Bool	<input type="checkbox"/> FALSE		<input type="checkbox"/>
4	*IOLPort*	%MW4	DEC	1	1	<input checked="" type="checkbox"/> ⚠
5	*IOLIndex*	%MW6	DEC	16	16	<input checked="" type="checkbox"/> ⚠
6	*IOLSubindex*	%MW8	DEC	0		<input type="checkbox"/>
7	*Len*	%MW10	DEC	32	32	<input checked="" type="checkbox"/> ⚠
8	*DoneValid*	%MO.2	Bool	<input checked="" type="checkbox"/> TRUE		<input type="checkbox"/>
9	*Busy*	%MO.3	Bool	<input type="checkbox"/> FALSE		<input type="checkbox"/>
10	*Error*	%MO.4	Bool	<input type="checkbox"/> FALSE		<input type="checkbox"/>
11	*Status*	%MD12	Hex	16#0000_0000		<input type="checkbox"/>
12	*IOLStatus*	%MD16	Hex	16#0000_0000		<input type="checkbox"/>
13	*RdLen*	%MW20	DEC	8		<input type="checkbox"/>
14		<Add new>				<input type="checkbox"/>

10. The **IO_LINK_CALL** is triggered on the positive edge of parameter **REQ**.

Once completed, check the value of tag **DoneValid**, **Busy**, **Error**, **Status**, **IOLStatus**, and **RdLen**. If the ISDU request was completed successfully, the **DoneValid** should be true. The **RdLen** contains the number of bytes returned. The actual data is stored in **Data_block_1.IOLData**.

IO_Link_Library_Demo ▶ PLC_1 [CPU 1212C AC/DC/Rly] ▶ Program blocks ▶ Data_block_1 [DB2]

	Name	Data type	Start value	Monitor value	Retain	Accessible f...
1	Static				<input type="checkbox"/>	<input type="checkbox"/>
2	IOLData	Array[0..231] of Byte			<input checked="" type="checkbox"/>	<input checked="" type="checkbox"/>
3	IOLData[0]	Byte	16#0	16#53	<input type="checkbox"/>	<input checked="" type="checkbox"/>
4	IOLData[1]	Byte	16#0	16#49	<input type="checkbox"/>	<input checked="" type="checkbox"/>
5	IOLData[2]	Byte	16#0	16#43	<input type="checkbox"/>	<input checked="" type="checkbox"/>
6	IOLData[3]	Byte	16#0	16#48	<input type="checkbox"/>	<input checked="" type="checkbox"/>
7	IOLData[4]	Byte	16#0	16#20	<input type="checkbox"/>	<input checked="" type="checkbox"/>
8	IOLData[5]	Byte	16#0	16#41	<input type="checkbox"/>	<input checked="" type="checkbox"/>
9	IOLData[6]	Byte	16#0	16#47	<input type="checkbox"/>	<input checked="" type="checkbox"/>
10	IOLData[7]	Byte	16#0	16#00	<input type="checkbox"/>	<input checked="" type="checkbox"/>
11	IOLData[8]	Byte	16#0	16#00	<input type="checkbox"/>	<input checked="" type="checkbox"/>
12	IOLData[9]	Byte	16#0	16#00	<input type="checkbox"/>	<input checked="" type="checkbox"/>

11.4. Diagnostic Alarm

Events from IO-Link master and IO-Link devices are mapped to PROFINET alarms and channel diagnostics according to the IO-Link on *PROFINET Working Document Version 13.4.2015* with some modifications.

11.4.1. IO-Link Event Mapping Overview

IO-Link events are mapped into **PROFINET Alarms and Channel Diagnostics** using the following table. Each appearing IO-Link event (mode Coming) results in adding channel diagnostics. Each disappearing IO-Link event (mode Going) results in removing channel diagnostics. IO-Link events that have mode Single will be mapped to PROFINET process alarm.

IO-Link Event Mapping	
IO-Link Event Mode	PROFINET
Single	Process alarm
Coming	Add channel diagnostics
Going	Remove channel diagnostics

In addition, only IO-Link events that have the type of Error or Warning are mapped to PROFINET channel diagnostics. Type Message IO-Link events are not mapped.

11.4.2. IO-Link EventCode Mapping

IO-Link events that are generated by IO-Link devices (remote events) are mapped to PROFINET diagnostics using **ChannelErrorType** 0x500 and 0x501.

- For an **EventCode** that is between 0x0000 and 0x7FFF, **ChannelErrorType** 0x500 is used. The **EventCode** is directly mapped to **ExtChannelErrorType**.
- For an **EventCode** that is between 0x8000-0xFFFF, **ChannelErrorType** 0x501 is used. The **EventCode** is mapped to **ExtChannelErrorType** with the MSB set to 0.
- For IO-Link events that are generated by IO-Link master (local events), **ChannelErrorType** 0x502 is used. **EventCode** is directly mapped to **ExtChannelErrorType**.

The following table summaries how IO-Link **EventCode** is mapped to PROFINET diagnostics.

IO-Link EventCode Mapping				
Source	EventCode	ChannelError Type	ExtChannel ErrorType	Comment
IO-Link Device (remote)	0x0000-0x7FFFF	0x500	0x0000-0x7FFFF	Direct mapping of EventCode to ExtChannelErrorType (e.g. EventCode 0x6321 will be mapped to ExtChannelErrorType 0x6321)
IO-Link Device (remote)	0x8000-0xFFFF	0x501	0x0000-0x7FFFF	Mapping of EventCode to ExtChannelErrorType . Set MSB (EventCode) to "0" (e.g. EventCode 0x8005 ExtChannelErrorType 0x0005)
IO-Link master (local)	0x0000-0x7FFFF	0x502	0x0000-0x7FFFF	Direct mapping of local EventCode to ExtChannelErrorType

The following table lists some of the **EventCode** that the Pepperl+Fuchs IO-Link master generates.

IO-Link EventCode	ExtChannelErrorType	Description
0x0001	0x0001	Slave PDU Flow
0x0002	0x0002	Master PDU checksum error
0x0003	0x0003	Slave illegal PDU
0x0004	0x0004	Master illegal PDU
0x0005	0x0005	Slave PDU buffer
0x0006	0x0006	Slave PD INKR
0x0007	0x0007	Slave PD length
0x0008	0x0008	Slave no PDI
0x0009	0x0009	Slave no PDO
0x000A	0x000A	Slave channel
0x000B	0x000B	Master event
0x000C	0x000C	Application message
0x000D	0x000D	Application warning
0x000E	0x000E	Application device
0x000F	0x000F	Application parameter
0x0010	0x0010	Slave device lost
0x0012	0x0012	Slave DESINA
0x001A	0x001A	Slave wrong sensor
0x001B	0x001B	Slave retry
0x001E	0x001E	Power short circuit
0x001F	0x001F	Power sensor
0x0020	0x0020	Power actuator
0x0021	0x0021	Power fault
0x0022	0x0022	Power reset
0x0023	0x0023	Slave fallback
0x0024	0x0024	Master preoperate
0x0028	0x0028	Data storage ready
0x0029	0x0029	Data storage identity fault
0x002A	0x002A	Data storage size fault
0x002B	0x002B	Data storage upload fault
0x002C	0x002C	Data storage download fault
0x002F	0x002F	Data storage device locked fault

The following images show a *Slave device lost* event that was available in the diagnostics when an IO-Link device was disconnected from an IO-Link port. In the figure, Slot 2 means that the device was connected to IO-Link Port 2. The event will be removed from the diagnostics when the device is reconnected to the same IO-Link port.

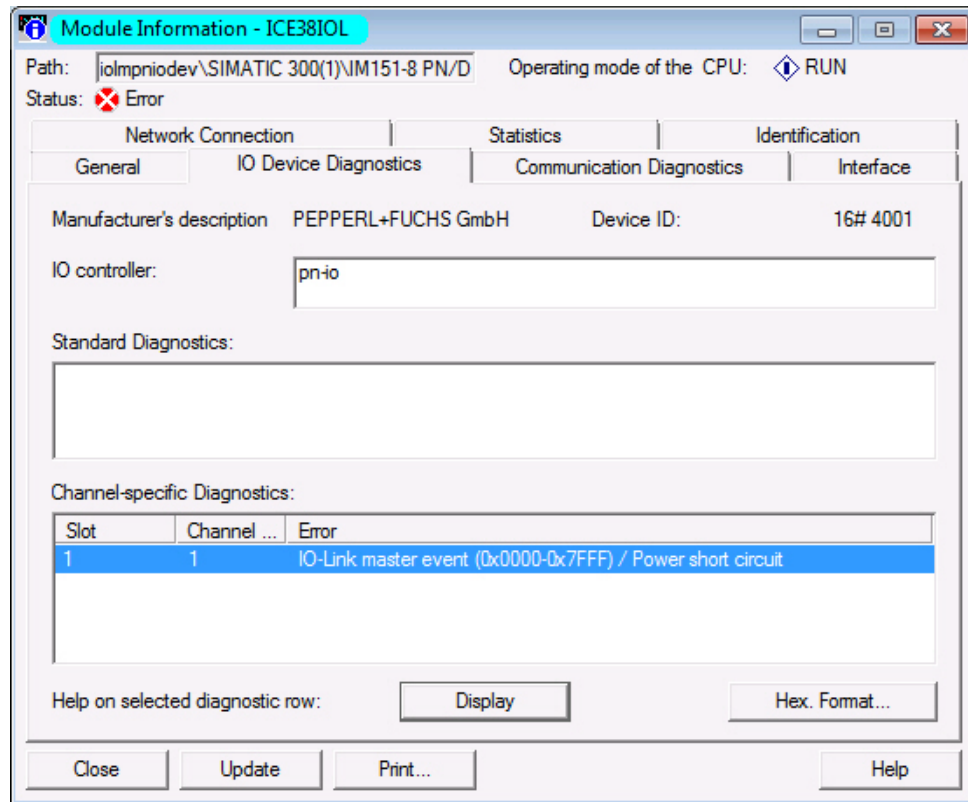

STEP 7 V5.5: IO-Link Events Through PROFINET Channel Diagnostics

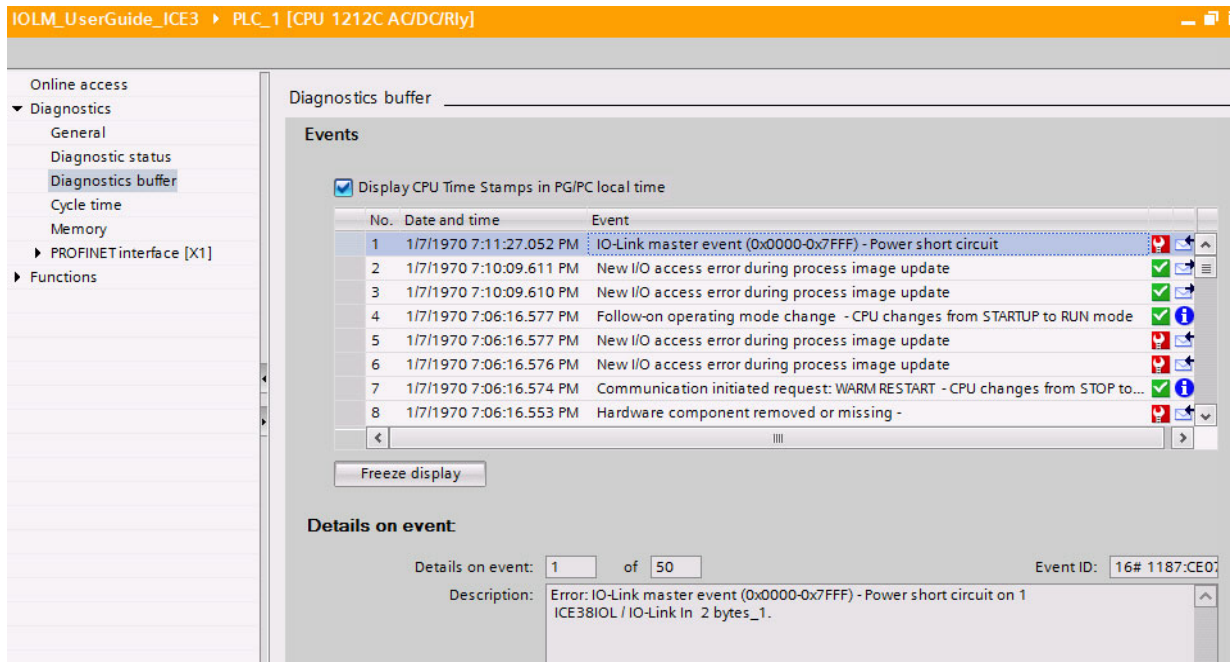

TIA Portal V13: IO-Link Events Through PROFINET Channel Diagnostics

2022-12

12. Modbus/TCP Interface

This chapter contains the following topics:

- *Modbus Function Codes* on Page 168
- *Modbus Address Definitions* on Page 168
- *Multiple Port Process Data (PDI/PDO) Access via Modbus/TCP* on Page 171
- *Modbus Read/Write Example* on Page 171

12.1. Overview

The IO-Link master features both a Slave-mode and Master-mode Modbus/TCP interface.

Slave mode:

- Read access to the Process Data Input (PDI) and Process Data Output (PDO) data blocks for each IO-Link port
- Write access to the PDO data block for each IO-Link port
- Write access to send ISDU requests to each IO-Link port
- Read access to ISDU responses from each IO-Link port
- Read access to the Port Information Block for each IO-Link port

Master mode:

- Read access to the Process Data Input (PDI) for each IO-Link port
- Write access to the PDO data block for each IO-Link port

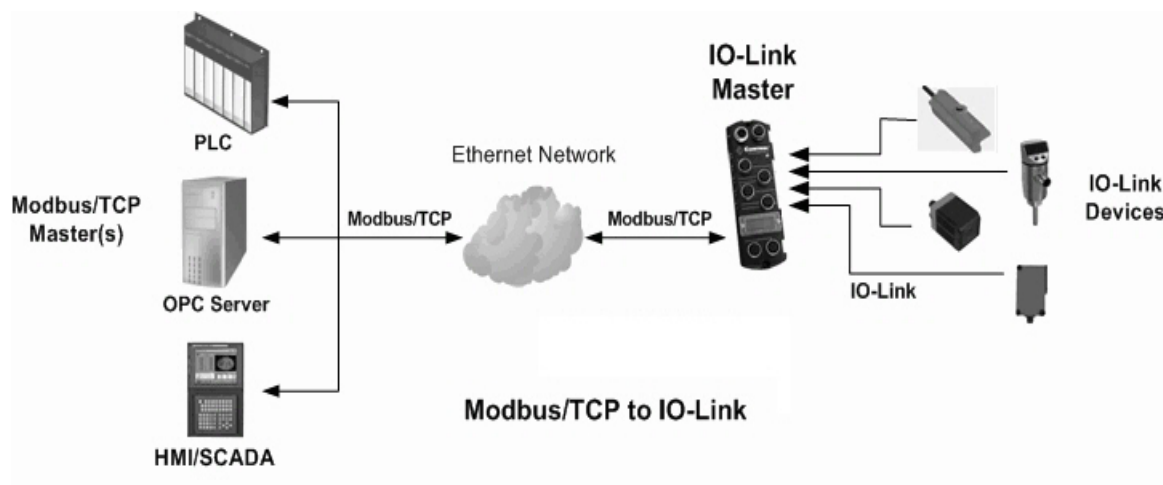

The Modbus interface is disabled by default. To enable Modbus/TCP:

1. Click **Configuration | Modbus/TCP**.
2. Click the **EDIT** button in the **Modbus/TCP Configuration** table and select **enable** in the **Modbus Enable** drop box.

Note: IO-Link master supports up to 64 Modbus/TCP connections.

The screenshot displays the 'Modbus/TCP Settings' configuration page. At the top, there is a navigation bar with 'PEPPERL+FUCHS' and various menu items like 'Home', 'Diagnostics', 'Configuration', 'Advanced', 'Attached Devices', and 'Support'. Below this is a sub-menu for 'MODBUS/TCP' with options for 'OPC UA', 'MQTT', 'NETWORK', 'MISC', 'LOAD/SAVE', and 'CLEAR SETTINGS'. The main content area is titled 'Modbus/TCP Settings' and contains a table for 'MODBUS/TCP PORT CONFIG' with columns for PORT 1 through PORT 8. Each port has an 'EDIT' button. Below the table are several sections of settings:

- ISDU Data Settings:** ISDU Response Timeout (1 - 10000) is set to 20 sec for all ports.
- Process Data Settings:** PDI Data Block Size (To PLC) is 36 bytes; PDI Byte-Swap Method is 'no byte-swap'; PDO Data Block Size (From PLC) is 32-bytes; PDO Byte-Swap Method is 'no byte-swap'; Append PDO to PDI Data is false; Clear Event Code In PDO Block is false; Clear Event Code After Hold Time is true; Active Event Hold Time (1 - 65535) is 1000 ms; Event Hold Time Units is ms; Clear Event Hold Time (1 - 65535) is 500 ms; Event Clear Time Units is ms.
- Transfer Mode Settings:** Slave Mode Device ID (1 - 247) is 1; PDI Receive Mode(s) (To PLC) is Slave; PDO Transmit Mode(s) (From PLC) is Slave.
- Modbus Master PLC Settings:** PLC ID Address (from PLC) is 0.0.0.

At the bottom, there is a 'MODBUS/TCP CONFIGURATION' section with a 'Modbus Enable' dropdown set to 'enable'. 'CANCEL' and 'SAVE' buttons are visible at the bottom right of the configuration area. The footer shows 'Welcome Admin' and '© Pepperl+Fuchs'.

3. Click the **SAVE** button.

Refer to *Modbus/TCP Functionality Descriptions* on Page 177 for detailed information about process data block descriptions, event handling, and ISDU handling.

- *Output Process Data Block Description* on Page 179
- *Output Process Data Block Description* on Page 179
- *Output Process Data Block-16 Bit (INT) Data Format* on Page 180
- *Event Handling* on Page 181
- *ISDU Handling* on Page 186

12.2. Modbus Function Codes

This table shows the supported Modbus function codes.

Message Type	Function Code	Maximum Message Size
Read Holding Registers	3	250 Bytes (125 Words)
Write Single Register	6	2 bytes (1 Word)
Write Multiple Registers	16 (10 hex)	246 Bytes (123 Words)
Read/Write Holding Registers	23 (17 hex)	Write: 242 bytes (121 Words) Read: 246 bytes (123 Words)

12.3. Modbus Address Definitions

The address definitions for the Modbus/TCP interface are shown in the following table.

Note: Addresses are listed in Base 1 and you must subtract 1 from each number if using Base 0 addressing.

	IO-Link Port 1	IO-Link Port 2	IO-Link Ports 3 -7	IO-Link Port 8	Access	Length
Multiple Port PDI Data Block(s)	1000	2000	...	8000	Read- Only	Configurable per port(s)
Port Specific PDI Data Block	1001	2001	...	8001	Read-Only	Configurable per port
Multiple Port PDO Data Block(s)	1050	2050	...	8050	Read/Write	Configurable per port(s)
Port Specific PDO Data Block	1051	2051	...	8051	Read/Write	Configurable per port
Receive ISDU Response	1101	2101	...	8101	Read-Only	4 to 125 Words
Transmit ISDU Request	1301	2301	...	8301	Write-Only	4 to 123 Words

	IO-Link Port 1	IO-Link Port 2	IO-Link Ports 3 -7	IO-Link Port 8	Access	Length
<i>Port Information Block (Continuous Block)</i>						232 Words
Vendor Name	1501)	2501	...	8501	Read-Only	64 Chars 32 Words
Vendor Text	1533	2533	...	8533	Read-Only	64 Chars 32 Words
Product Name	1565	2565	...	8565	Read-Only	64 Chars 32 Words
Product Id	1597	2597	...	8597	Read-Only	64 Chars 32 Words
Product Text	1629	2629	...	8629	Read-Only	64 Chars 32 Words
Serial Number	1661	2661	...	8661	Read-Only	16 Chars 8 Words
Hardware Revision	1669	2669	...	8669	Read-Only	64 Chars 32 Words
Firmware Revision	1701	2701	...	8701	Read-Only	64 Chars 32 Words
Device PDI Length	1733	2733	...	8733	Read-Only	1 Word
Device PDO Length	1734	2734	...	8734	Read-Only	1 Word

12.4. Port Configuration Block

The following table illustrates the Modbus port configuration block. For more information, refer to *Modbus Read/Write Example* on Page 171.

Note: Subtract 1 from each address if you are using Base 0 addressing (i.e. 1000 becomes 999, 8050 becomes 8049, etc).

Description	IO-Link Port 1	IO-Link Port 2	IO-Link Ports 3 -7	IO-Link Port 8	Legal Values
Configuration Write Key	1881	2881	...	8881	61453
Port Mode	1882	2882	...	8882	0 – 3 (0 = Reset, 1 = IO-Link, 2 = DigitalIn, 3 = DigitalOut)
ISDU Response Timeout	1883	2883	...	8883	1 - 10000
PDI Data Block Size	1884	2884	...	8884	4,8,10,16,20,24,36
PDI Byte-Swap Method	1885	2885	...	8885	0 – 3 (0 = no byte-swap, 1 = word, 2 = dword, 3 = reverse registers)

Description	IO-Link Port 1	IO-Link Port 2	IO-Link Ports 3 -7	IO-Link Port 8	Legal Values
PDO Data Block Size	1886	2886	...	8886	0,4,8,10,16,20,24,32,34
PDO Byte-Swap Method	1887	2887	...	8887	0 – 3 (0 = no byte-swap, 1 = word, 2 = dword, 3 = reverse registers)
Append PDO to PDI Data	1888	2888	...	8888	0 for false, everything else for true
Clear Event Code in PDO Block	1889	2889	...	8889	0 for false, everything else for true
Clear Event Code After Hold Time	1890	2890	...	8890	0 for false, everything else for true
Active Event Hold Time	1891	2891	...	8891	any 16 bit value > 0
Event Hold Time Units	1892	2892	...	8892	0 – 4 (0 = ms, sec, min, hours, 4 = days)
Clear Event Hold Time	1893	2893	...	8893	any 16 bit value > 0
Event Clear Time Units	1894	2894	...	8894	0 – 4 (0 = ms, sec, min, hours, 4 = days)
Slave Mode Device ID	1895	2895	...	8895	1 - 247
PDI Receive Mode(s)	1896	2896	...	8896	0 (Slave)
PDO Transmit Mode(s)	1897	2897	...	8897	0 (Disabled), 1 (Slave)
PLC IP Address (octet 1)	1898	2898	...	8898	0 - 255
PLC IP Address (octet 2)	1899	2899	...	8899	0 - 255
PLC IP Address (octet 3)	1900	2900	...	8900	0 - 255
PLC IP Address (octet 4)	1901	2901	...	8901	0 - 255
PLC Device ID	1902	2902	...	8902	
PDI Data Address	1903	2903	...	8903	1 - 65535
PLC Ma1 Update Rate	1904	2904	...	8904	10 - 10000
Heartbeat Update Rate	1905	2905	...	8905	50 - 10000
PDO Data Address	1906	2906	...	8906	1 - 65535
PLC Poll Rate	1907	2907	...	8907	10 - 10000

12.5. Multiple Port Process Data (PDI/PDO) Access via Modbus/TCP

The PDI and PDO data for multiple ports can be received or transmitted by one message. For example, below you can see that the Modbus request is in Base1 and is for Address 1000 (Multiple Port PDI) and request for 54 words (128 bytes) which is enough for three ports (assuming each port is configured for 36 bytes of data (36 bytes * 3 = 108 bytes = 54 words)). Note that there is no sensor attached for Port 2.

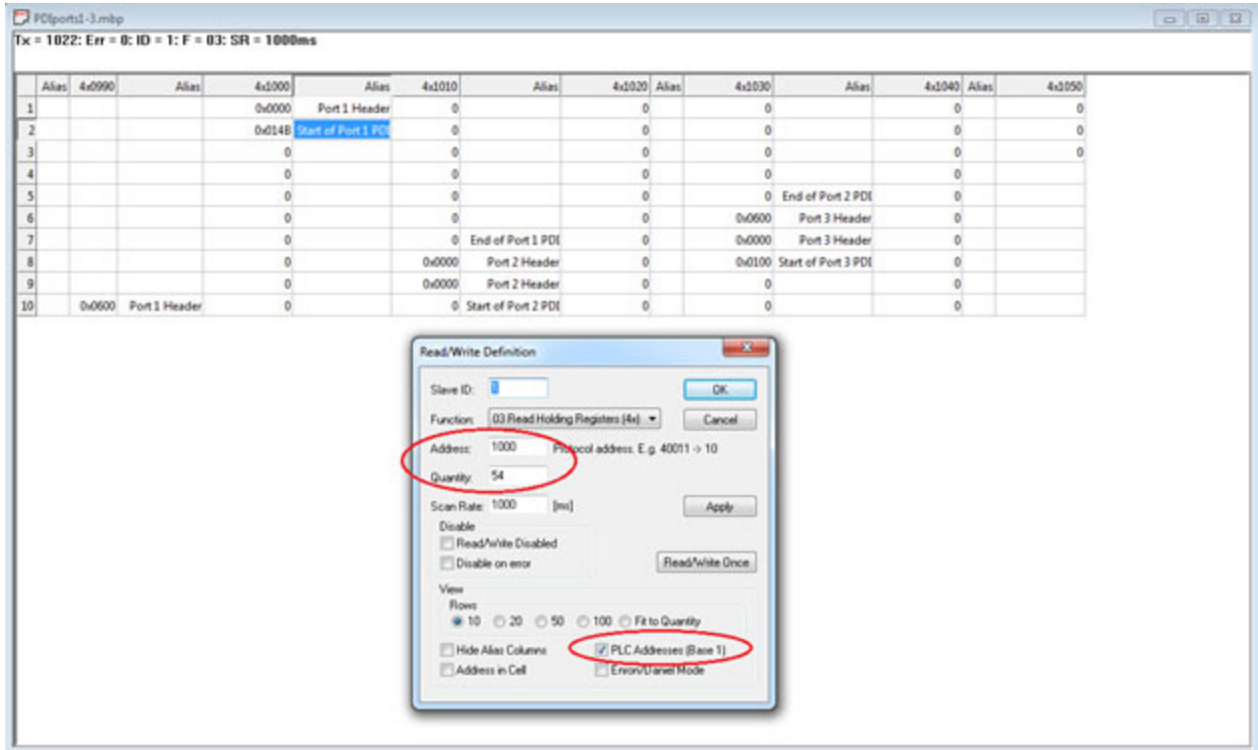

To receive and transmit process data for eight ports, it may be necessary to adjust the size of the PDI/PDO data blocks. The maximum read in Modbus is 125 words (250 bytes) and the maximum write is 123 words (246 bytes). If each port is configured for 36 bytes of PDI, you can read all of the PDI from ports 1-6 (36 bytes * 6 = 216 bytes) plus 34 out of the 36 bytes of port 7's PDI. Similarly, if you want to write PDO for multiple ports in one message, if each port is configured for 32 bytes of PDO, you can write PDO for 7 ports in one message (32 bytes * 7 = 224 bytes). A partial write for port 8 is not supported because partial writes of PDO are not allowed (only partial reads of PDI/PDO are allowed)

12.6. Modbus Read/Write Example

This section explains more about writing configuration data to the IO-Link Master. The example image from Modbus Poll can be adapted for use with your PLC.

12.6.1. Modbus Configuration Data

There are 27 two-byte registers to provide data. It is not required to provide data for all fields. For example, you can set the **Quantity** field to 10 and not write the last 17 registers worth of Modbus configuration data.

2022-12

The first register is a **Write key** that must be set to decimal 61453. If it is not set to that value then the configuration data will not be written.

The second register is for the **IOLink config** field that sets the **Port Mode**. Any value other than the defined values are rejected and a message appears in the Modbus diagnostics.

- 0 = **Reset**
- 1 = **IOLink**
- 2 = **DigitalIn**
- 3 = **DigitalOut**

The remainder of the two-byte registers are for the Modbus configuration values displayed in the Web UI. The fields are expected to be in the same order as you see in the Web UI:

- ISDU Response Timeout
- PDI Data Block Size
- PDI Byte-Swap Method and so forth

When providing data, if the field is a number, like **PDO Data Block Size**, **Active Event Hold Time**, etc. then provide that value. If the field is not numeric, such as **PDI Byte-Swap Method** then provide an integer correlating to your choice in the Web UI drop-down menu. For example:

PDI Byte-Swap Method

- 0 = no byte-swap
- 1 = word (16 bit) byte-swap
- 2 = dword (32 bit) byte-swap
- 3 = reverse registers

Remember, this is the exact order of those choices on the Web UI. Lastly, if the field is true/false, use a 0 for false and a 1 for true.

The screenshot displays the 'Modbus/TCP Settings' page in the Pepperl+Fuchs web interface. The page is organized into several sections:

- MODBUS/TCP PORT CONFIG:** A table with 8 columns and 1 row, with the last cell containing 'PORT 8' and an 'EDIT' button.
- ISDU Data Settings:** A table with 8 columns and 1 row, with the last cell containing '124 sec' (circled in red).
- Process Data Settings:** A table with 8 columns and 1 row, currently empty.
- MODBUS/TCP CONFIGURATION:** A table with 2 columns and 1 row, with the first cell containing 'Modbus Enable' and the second cell containing 'enable', with an 'EDIT' button.

The interface includes a navigation bar at the top with links for Home, Diagnostics, Configuration, Advanced, Attached Devices, and Support. A footer at the bottom shows 'Welcome Admin' and '© Pepperl+Fuchs'.



13. Modbus/TCP Functionality Descriptions

This chapter discusses the following for Modbus/TCP:

- *Process Data Block Descriptions*
- *Event Handling* on Page 181
- *ISDU Handling* on Page 186

13.1. Process Data Block Descriptions



This subsection discusses the following:

- *Input Process Data Block Description* on Page 178
- *Output Process Data Block Description* on Page 179

13.1.1. Input Process Data Block Description

The following tables describe the Input Process Data Block.

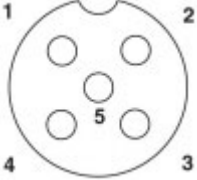
Parameter Name	Data Type	Description
Port Status	BYTE	<p>The status of the IO-Link device.</p> <p>Bit 0 (0x01): 0 = IO-Link port communication initialization process is inactive 1 = IO-Link port communication initialization process is active</p> <p>Bit 1 (0x02): 0 = IO-Link port communication is not operational 1 = IO-Link port communication is operational</p> <p>Bit 2 (0x04): 0 = IO-Link input process data is not valid. 1 = IO-Link input process data is valid.</p> <p>Bit 3 (0x08): 0= No fault detected 1= Fault detected</p> <ul style="list-style-type: none"> • A minor communication fault is indicated by the Operational status bit being set to 1. A minor communication fault results from: <ul style="list-style-type: none"> - A temporary loss of communication to the IO-Link device. - A recoverable IO-Link master software or hardware fault. • A major communication fault is indicated by the Operational bit being set to 0. <ul style="list-style-type: none"> - An unrecoverable loss of communication to the IO-Link device. - An unrecoverable IO-Link master software or hardware fault. <p>Bits 4-7: Reserved (0)</p>

Parameter Name	Data Type	Description
Auxiliary I/O	BYTE	<p>The auxiliary bit on the IO-Link port is:</p> <ul style="list-style-type: none"> Pin 2 on the ICE3-8IOL-G65L-V1D or ICE3-8IOL1-G65L-V1D  <ul style="list-style-type: none"> DI (labeled as 3 on the device) on the ICE3-8IOL-K45P-RJ45 and ICE3-8IOL-K45S-RJ45  <p>Bit 0 (0x01): The status of the auxiliary bit. 0 = off 1 = on</p> <p>Bits 1-3: Reserved (0) Bits 4-7: Reserved (0)</p>
Event Code	INT	16-bit event code received from the IO-Link device.
PDI Data <i>Default Length = 32 bytes</i>	Array of up to 32 BYTES	<p>The PDI data as received from the IO-Link device. May contain from 0 to 32 bytes of PDI data. The definition of the PDI data is device dependent.</p> <p>Note: <i>Length is configurable, refer to Modbus/TCP Settings Configuration Page on Page 90 for more information.</i></p>

13.1.2. Output Process Data Block Description

The contents of the Output Process Data Block are configurable.

Parameter Name	Data	Description
Clear Event Code in PDO Block (Configurable option) <i>Default:</i> Not included	INT	If included, allows clearing of 16-bit event code received in the PDI data block via the PDO data block.
PDO Data <i>Default Length = 32 bytes</i>	Array of up to 32 BYTES	The PDO data written to the IO-Link device. May contain from 0 to 32 bytes of PDO data. The definition and length of the PDO data is device dependent.

2022-12

13.1.2.1. Output Process Data Block-16 Bit (INT) Data Format

Without the **Clear Event Code in PDO Block** option selected:

Word	Bit 15	Bit 0
0	PDO Data Word 0	
1	PDO Data Word 1	
..	..	
..	..	
N-1	PDO Data Word (N-1)	

With the **Clear Event Code in PDO Block** option selected:

Word	Bit 15	Bit 0
0	Event Code	
1	PDO Data Word 0	
2	PDO Data Word 1	
..	..	
..	..	
N	PDO Data Word (N-1)	

13.2. Event Handling

The IO-Link master event handling is designed to provide real-time updates of event codes received directly from the IO-Link device. The IO-Link event code:

- Is included in the second 16-bit word of the Input Process Data (PDI) block.
 - An active event is indicated by a non-zero value.
 - Inactive or no event is indicated by a zero value.
- Two methods are provided to clear an event:
 - Enable the *Clear Event After Hold Time* option.
 - The IO-Link master keeps, or holds, the active event code in the PDI block until the configured *Active Event Hold Time* has passed.
 - The IO-Link master then clears the event code in the PDI block and waits until the *Clear Event Hold Time* has passed before including another event code in the PDI block.
 - Enable the *Clear Event In PDO Block* option.
 - The IO-Link master monitors the PDO block received from the PLC.
 - The IO-Link master expects the first entry of the PDO block to indicate an event code to be cleared.
 - If there is an active event code in the PDI block and the PDO block also contains the same event code, the event code is cleared in the PDI block.
 - The IO-Link master then clears the event code in the PDI block and waits until the *Clear Event Hold Time* has passed before including another event code in the PDI block.
- The two methods can be used separately or together to control the clearing of events.

The next subsections illustrate the event clearing process for the various event configurations.



13.2.1. Clear Event After Hold Time Process

This illustrates clearing the event after the hold time process.

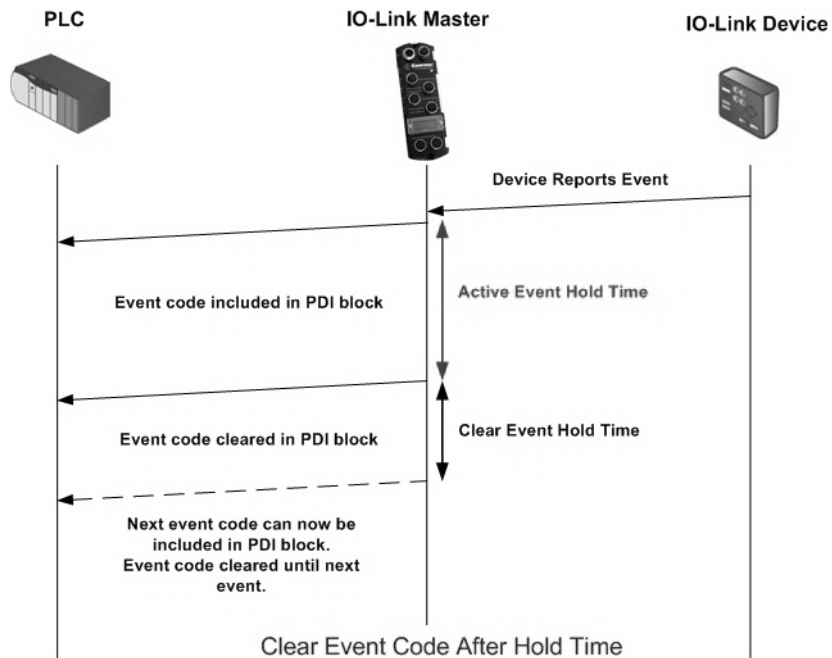



13.2.2. Clear Event in PDO Block Process

This illustrates clearing the event in the PDO block process.

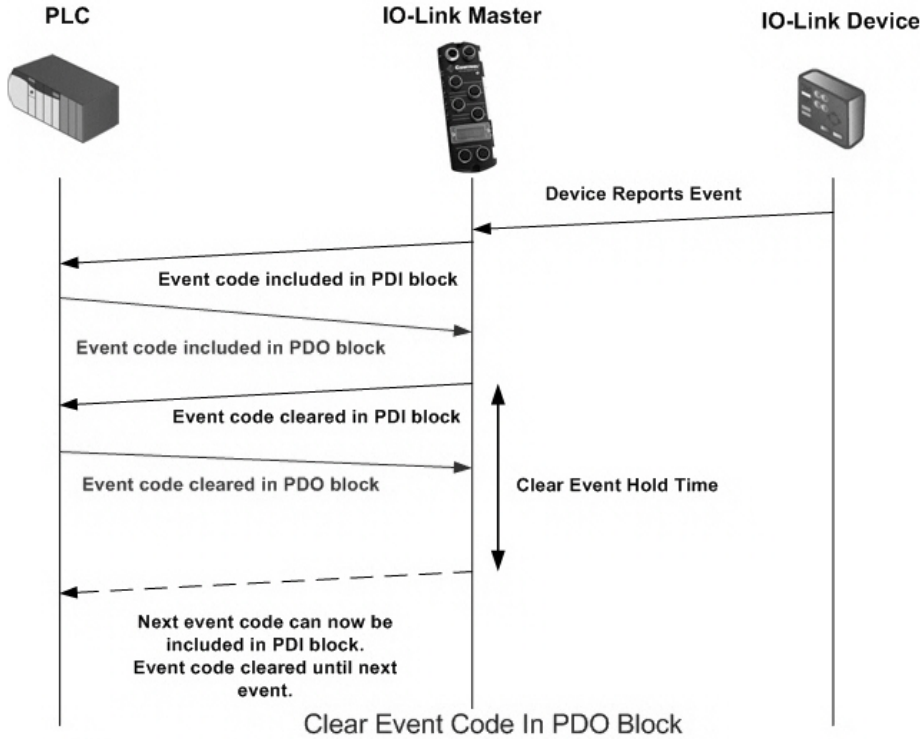

13.2.3. Clear Event Code in PDO Block and Clear Event After Hold Time Process-PDO Block First

This illustrates clearing the event code in the PDO block and clearing the event after the hold time process with the PDO block first.

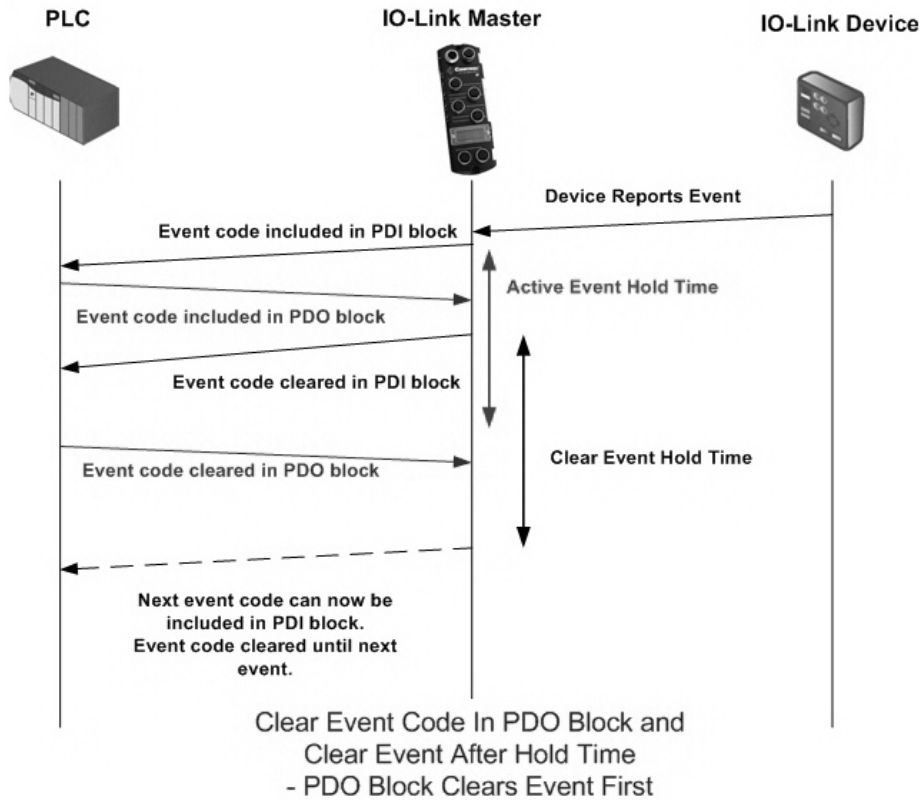

13.2.4. Clear Event Code in PDO Block and Clear Event After Hold Time Process-Hold Time Expires

This illustrates clearing the event code in the PDO block and clearing the event after the hold time process with the hold time expired.

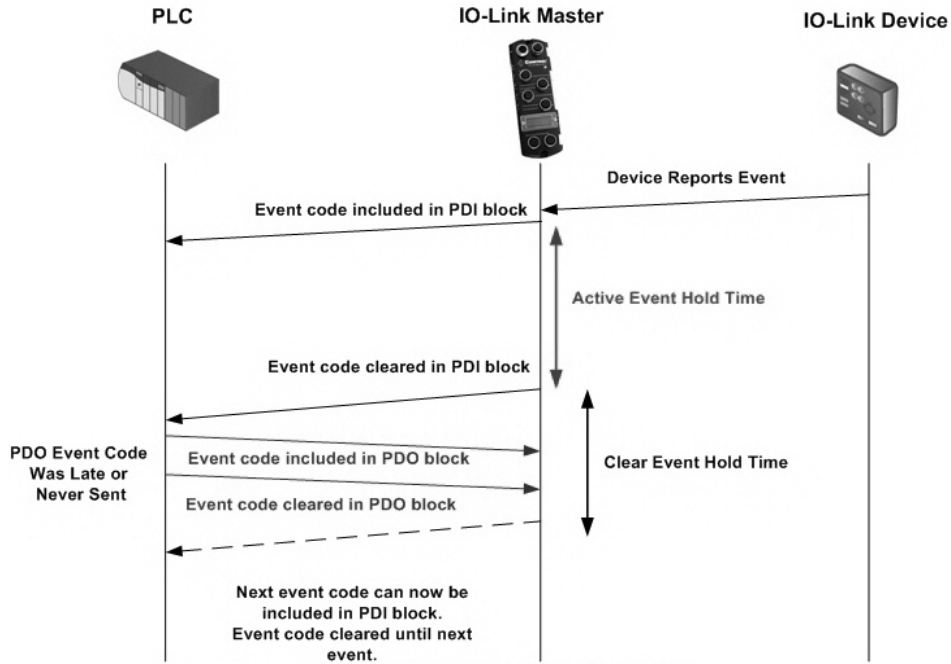

Clear Event Code In PDO Block and Clear Event After Hold Time
 - Hold Time Expires and Clears Event



13.3. ISDU Handling

The ISDU interface contains the following:

- An ISDU *request* may contain one or multiple individual ISDU read and/or write *commands*.
- Individual ISDU command based byte swapping capabilities.
- Variable sized command structures to allow access to wide range of ISDU block sizes.
- A single ISDU request may contain as many ISDU read and/or write commands as allowed by the industrial protocol payload. For example, if an industrial protocol provides up to 500 byte read/write payloads, then an ISDU request may contain multiple commands of various lengths that can total up to 500 bytes in length.

13.3.1. ISDU Request/Response Structure

ISDU requests may contain a single command or multiple, nested commands. This subsection discusses the following:

- *Single ISDU Command Request*
- *Multiple ISDU Command Structure on Page 187*

13.3.1.1. Single ISDU Command Request

This illustrates a single ISDU command request.

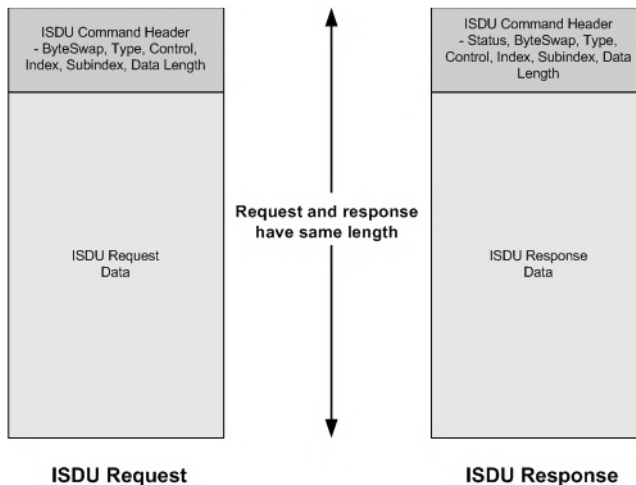

Single Command ISDU Request/Response



13.3.1.2. Multiple ISDU Command Structure

ISDU requests with multiple commands may consist of commands of the same data size or commands with different data sizes. Multiple Command ISDU Request/Response of Different Data Lengths

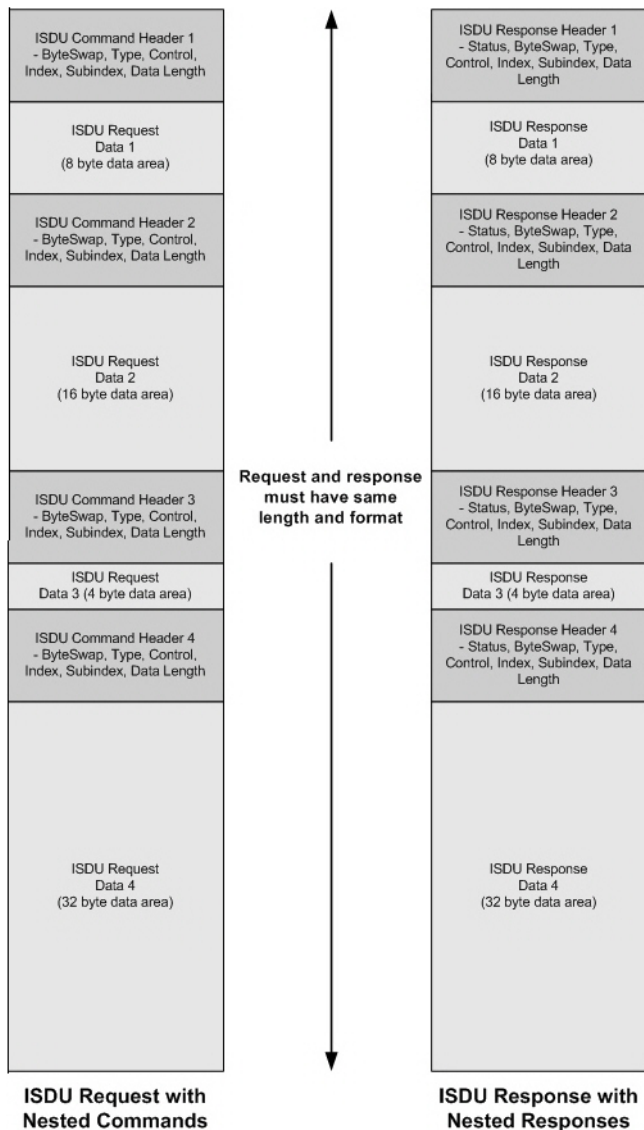

Example - Multiple Command ISDU Request/Response of Different Data Area Lengths

13.3.2. ISDU Request Message Format-From PLC to IO-Link master

Write and read ISDU commands have the same message data format. Each ISDU request message is comprised of one or more commands. The command(s) can consist of either a series of nested commands or a single command.

A list of nested ISDU commands is terminated with either a control field of 0, (single/last operation), or the end of the message data.

In the following tables, these are the *common* choices for each field, which should illustrate a simple ISDU:

- Byte Swapping – set this entire byte to 0
- RdWrControlType – use a 1 or 2 for the lower nibble and a 0 for the upper nibble
- Index – whichever you would like to use
- Subindex – whichever you would like to use
- Datalength – however many bytes you want to write or expect to read

13.3.2.1. Integer (16-Bit Word) ISDU Request Command Format

This table shows an integer (16 bit word) ISDU request command format with Modbus/TCP.

Name	Data Type	Parameter Description
Byte Swapping / RdWrControlType	UINT	Provides the control, type and byte swapping of ISDU command Bits 0-3, Type Field: 0 = NOP (No operation) 1 = Read operation 2 = Write operation 3 = Read/Write "OR" 4 = Read/Write "AND" Bits 4-7, Control Field: 0 = Single/Last Operation (length can vary from to 1 to 232) 1 = Nested batch command – fixed 4 byte data area 2 = Nested batch command – fixed 8 byte data area 3 = Nested batch command – fixed 16 byte data area 4 = Nested batch command – fixed 32 byte data area 5 = Nested batch command – fixed 64 byte data area 6 = Nested batch command – fixed 128 byte data area 7 = Nested batch command – fixed 232 byte data area Bits 8-11: 0= No byte swapping. 1= 16-bit (INT) byte swapping of ISDU data. 2= 32-bit (DINT) byte swapping of ISDU data. Bits 12-15: Set to zero. Unused.
Index	UINT	The parameter address of the data object in the IO-Link device.
Subindex	UINT	The data element address of a structured parameter of the data object in the IO-Link device.
Datalength	UINT	Length of data to read or write. For nested batch commands, the data length can vary from 1 to the fixed data area size.

2022-12



Name	Data Type	Parameter Description
Data	Array of USINTs, UINTs, or UDINTs.	Size of array is determined by the Control field in RdWrControlType. Note: <i>Data is valid only for write commands.</i>

13.3.3. ISDU Response Message Format

The ISDU responses have the same data format as requests with the only exception being the returned command status. Each ISDU response message is comprised of one or more responses to the single and/or nested command(s) received in the request.

13.3.3.1. Integer (16-Bit Word) ISDU Response Command Format

The following table shows an integer (16-bit word) ISDU response command format with Modbus/TCP.

Name	Data Type	Parameter Descriptions
Status, Byte-Swapping, RdWrControlType	UINT	<p>Indicates the control, type, byte swapping and status of the ISDU command.</p> <p>Bits 0-3, Type Field:</p> <ul style="list-style-type: none"> 0 = NOP (No operation) 1 = Read operation 2 = Write operation 3 = Read/Write "OR" 4 = Read/Write "AND" <p>Bits 4-7, Control Field:</p> <ul style="list-style-type: none"> 0 = Single/Last Operation (length can vary from to 1 to 232) 1 = Nested batch command – fixed 4 byte data area 2 = Nested batch command – fixed 8 byte data area 3 = Nested batch command – fixed 16 byte data area 4 = Nested batch command – fixed 32 byte data area 5 = Nested batch command – fixed 64 byte data area 6 = Nested batch command – fixed 128 byte data area 7 = Nested batch command – fixed 232 byte data area <p>Byte swapping, bits 8-11:</p> <ul style="list-style-type: none"> 0= No byte swapping. 1= 16-bit (INT) byte swapping of TX/RX ISDU data. 2= 32-bit (DINT) byte swapping of TX/RX ISDU data. <p>Status, bits 12-15:</p> <ul style="list-style-type: none"> 0 = NOP (No operation) 1 = In process (Only valid for non-blocking requests) 2 = Success 3 = Failure: IO-Link device rejected the request. 4 = Timed out: IO-Link device did not respond
Index	UINT	The parameter address of the data object in the IO-Link device
Subindex	UINT	The data element address of a structured parameter of the data object in the IO-Link device.
Datalength	UINT	Length of data that was read or written. For nested batch commands, the data length can vary from 1 to fixed data area size.
Data	Array of USINTs, UINTs, or UDINTs	<p>Data returned for read commands. Contains the data of a write command.</p> <p>The size of the array is determined by the Control field in RdWrControlType.</p> <p>Note: Data field not required for single NOP commands.</p>

2022-12

14. OPC UA Supporting Information

14.1. OPC UA Server

The IO-Link master is an OPC UA Server, which can support up to 8 connected clients. Client examples include:

- Inductive Automation Ignition
- Kepware KEPServerEX
- GE Proficy Operation Hub
- PTC ThingWorx
- Corporate MES systems
- Custom programs like python, C++, C#, etc.

Enabling the server connection in the IO-Link master web interface allows the connected clients to read PDI data from all ports and send PDO data to any port and read / write ISDU parameter data to any port. Writing PDO data has to be enabled on a per port basis and ISDU writes have to be enabled per protocol.

- Limitations on the OPC UA connection are 8 sessions and 16 instances
- Maximum Sampling Rate is 50ms
- Supported Authentication includes Anonymous, Username/Password and certificate
- Supported Security includes None, Basic256, Basic256Sha256 with sign, sign & encrypt

A client has to be setup to communicate to an OPC UA server – in general terms the client must first connect to the I/O block OPC UA endpoint which is the IP address and port number (if a non-standard port is used). The IO-Link master uses the standard port of 4840. Using Anonymous authentication and None for security is the simplest type of connection.

Having the respective IODD file loaded for an IO-Link device the process data (PDI and PDO) is parsed based on the IODD file and these variables are made available to OPC UA clients instead of just the raw data.

- Server Certificate Source: None, Default Web Server Certificate, Custom Certificate Below
- Server Certificate: Allows a user to load a X509 certificate for the ICE2/3 OPC UA server
- Server Private Key: Allows a user to load the private key for the ICE OPC UA server
- Client Authentication Certificate #1 and #2: Allows a user to load 2 separate client authentication certificates

PEPPERL+FUCHS Home Diagnostics Configuration Advanced Attached Devices Support ICE3-BIOL-K455-R045 Logout

IO-LINK PROFINET IO MODBUS/TCP **OPC UA** MQTT NETWORK MISC LOAD/SAVE CLEAR SETTINGS

OPC UA Settings

OPC UA PORT CONFIG	PORT 1	PORT 2	PORT 3	PORT 4	PORT 5	PORT 6	PORT 7	PORT 8
	CANCEL SAVE	EDIT	EDIT	EDIT	EDIT	EDIT	EDIT	EDIT
Allow OPC UA clients to write PDO data	enable	disable	disable	disable	disable	disable	disable	disable

OPC UA CONFIGURATION CANCEL SAVE

OPC UA Server Enable	enable
Work-around for faulty OPC UA clients that require unique browsenames	disable
Show only currently selected process data groups	disable
Allow OPC UA clients to write ISDU data	disable
ApplicationName	<input type="text"/>
ApplicationURI	<input type="text"/>
Username	<input type="text"/>
Password	<input type="checkbox"/> Change New Password: <input type="text"/> Confirm Password: <input type="text"/>
Server Certificate Source	None [encryption disabled]
Server Certificate	Browse... No file selected.
Server Private Key	Browse... No file selected.
Client Authentication Certificate #1	Browse... No file selected.
Client Authentication Certificate #2	Browse... No file selected.

Welcome Admin © Pepperl+Fuchs

Refer to *OPC UA Settings Configuration Page* on Page 96 for more information.

14.1.1.PDI Data

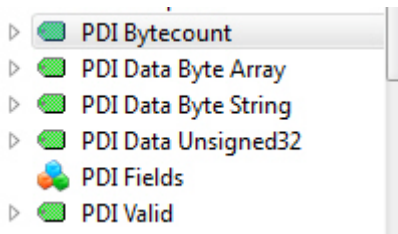

Field	Description
PDI Valid	Is true when a device PDI data is valid
PDI Byte Count	The number of PDI bytes from the device
PDI Data Byte Array	PDI data in a Byte Array data type [1 to 32 bytes]
PDI Data Byte String	PDI data in a Byte String data type [1 to 32 bytes]
PDI Data Unsigned32	PDI data in a Unsigned32 data type [1 to 8 bytes (LSB)]
PDI Fields	Nodes will be populated based on the Process Data section of the IODD

14.1.2.PDO Data

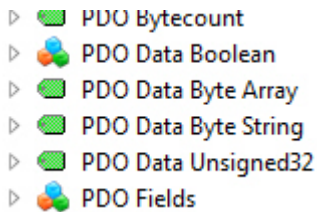

Field	Description
PDO Valid	Is true when a protocol is controlling the PDO to the device
PDO Byte Count	The number of PDO bytes sent to the device
PDO Data Byte Array	PDO data in a Byte Array data type [1 to 32 bytes]
PDO Data Byte String	PDO data in a Byte String data type [1 to 32 bytes]
PDO Data Unsigned32	PDO data in a Unsigned32 data type [1 to 8 bytes (LSB)]
PDO Fields	Nodes will be populated based on the Process Data section of the IODD ISDUs events

14.2. Data Model

Dynamic Nodes (e.g. IOLM/Port 1/Attached Devices/PDI Fields and IOLM/Port 1/Attached Devices/PDO Fields) are generated automatically and depend on specific IODD implementation, which cannot be generalized.

Node	Name space	Identifier (string)	Description	Data Type	Read / Write Access
Model	1	"IOLM/Model"	IO-Link Master type name	String	RO
Serial	1	"IOLM/Serial"	IO-Link Master serial number	String	RO
Manufacturer	1	"IOLM/Manufacturer"	IO-Link Master manufacturer	String	RO
Version	1	"IOLM/Version"	IO-Link Master firmware version	String	RO
Hostname	1	"IOLM/Hostname"	IO-Link Master hostname	String	RO
Uptime	1	"IOLM/Uptime"	IO-Link Master operational time (in s)	UInt32	RO
Name	1	"IOLM/Port 1/Name"	User configured port name	String	RO
Aux Input	1	"IOLM/Port 1/Aux Input"	State of AUX input (Pin2)	Boolean	R / W [4]
Uptime	1	"IOLM/Port 1/Uptime"	IO-Link port operational time (in s)	UInt32	RO
SIO Input	1	"IOLM/Port 1/SIO Input"	SIO Input state	Boolean	RO
SIO Output	1	"IOLM/Port 1/SIO Output"	SIO Output state	Boolean	RO
PDO Lock Enable	1	"IOLM/Port 1/PDO Lock Enable"	Allow protocol applications to lock PDO ownership	Boolean	RO
PDO Locked	1	"IOLM/Port 1/PDO Locked"	PDO ownership is locked by protocol application	Boolean	RO
Mode	1	"IOLM/Port 1/Mode"	Port I/O mode	String	RO
Status	1	"IOLM/Port 1/Status"	Port connection status	String	RO
Serial	1	"IOLM/Port 1/Attached Device/Serial"	Attached device serial number	String	RO
Vendor ID	1	"IOLM/Port 1/Attached Device/Vendor ID"	Attached device vendor ID number	UInt32	RO
Vendor Name	1	"IOLM/Port 1/Attached Device/Vendor Name"	Attached device vendor name	String	RO
Device ID	1	"IOLM/Port 1/Attached Device/Device ID"	Attached device ID number	UInt32	RO

2022-12

Node	Name space	Identifier (string)	Description	Data Type	Read / Write Access
Product Name	1	"IOLM/Port 1/Attached Device/Product Name"	Attached device product name	String	RO
IO-Link Version	1	"IOLM/Port 1/Attached Device/IO-Link Version"	Attached device protocol version	String	RO
HW Version	1	"IOLM/Port 1/Attached Device/HW Version"	Attached device hardware version	String	RO
FW Version	1	"IOLM/Port 1/Attached Device/FW Version"	Attached device firmware version	String	RO
ISDU Capable	1	"IOLM/Port 1/Attached Device/ISDU Capable"	Attached device is ISDU capable	Boolean	RO
DS Capable	1	"IOLM/Port 1/Attached Device/DS Capable"	Attached device is Data-Storage capable	Boolean	RO
PDI Bytecount	1	"IOLM/Port 1/Attached Device/PDI Bytecount"	Attached device PDI size in bytes	UInt32	RO
PDO Bytecount	1	"IOLM/Port 1/Attached Device/PDO Bytecount"	Attached device PDO size in bytes	UInt32	RO
Actual Cycle Time	1	"IOLM/Port 1/Attached Device/Actual Cycle Time"	IO-Link cycle time in μ s	UInt32	RO
Device Minimum Cycle Time	1	"IOLM/Port 1/Attached Device/Device Minimum Cycle Time"	IO-Link minimum cycle time in μ s	UInt32	RO
PDI Data Byte String	1	"IOLM/Port 1/Attached Device/PDI Data Byte String"	PDI data from IO-Link device as byte string	Byte String	RO
PDI Data Unsigned32	1	"IOLM/Port 1/Attached Device/PDI Data Unsigned32"	PDI data from IO-Link device as unsigned 32-bit integer	UInt32	RO
PDI Data Byte Array	1	"IOLM/Port 1/Attached Device/PDI Data Byte Array"	PDI data from IO-Link device as array of bytes	Byte Array	RO
PDI Valid	1	"IOLM/Port 1/Attached Device/PDI Valid"	PDI data valid flag from IO-Link device	Boolean	RO
PDO Data Byte String	1	"IOLM/Port 1/Attached Device/PDO Data Byte String"	PDO data from IO-Link device as byte string	Byte String	R / W [1]
PDO Data Unsigned32	1	"IOLM/Port 1/Attached Device/PDO Data Unsigned32"	PDO data from IO-Link device as unsigned 32-bit integer	UInt32	R / W [1]
PDO Data Byte Array	1	"IOLM/Port 1/Attached Device/PDO Data Byte Array"	PDO data from IO-Link device as array of bytes	Byte Array	R / W [1]
PDO Valid	1	"IOLM/Port 1/Attached Device/PDO Valid"	PDO data valid flag sent to IO-Link device	Boolean	R / W [1]
Unread	1	"IOLM/Port 1/Event Queue/Unread"	Unread event count	UInt32	RO

2022-12

Node	Name space	Identifier (string)	Description	Data Type	Read / Write Access
Counter	1	"IOLM/Port 1/Event Queue/Counter"	Event counter	UInt32	RO
Overflow	1	"IOLM/Port 1/Event Queue/Overflow"	Event overflow count	UInt32	RO
Counter Ack	1	"IOLM/Port 1/Event Queue/Counter Ack"	Event counter acknowledge	UInt32	R / W
Event Instance	1	"IOLM/Port 1/Event Queue/Event Instance"	Event instance value	UInt32	RO
Event Mode	1	"IOLM/Port 1/Event Queue/Event Mode"	Event mode value	UInt32	RO
Event Type	1	"IOLM/Port 1/Event Queue/Event Type"	Event type value	UInt32	RO
Event Code	1	"IOLM/Port 1/Event Queue/Event Code"	Event code value	UInt32	RO
Event Local	1	"IOLM/Port 1/Event Queue/Event Local"	Event local flag	UInt32	RO
Event Pdvalid	1	"IOLM/Port 1/Event Queue/Event Pdvalid"	Event pdvalid flag	UInt32	RO
Event String	1	"IOLM/Port 1/Event Queue/Event String"	Event String	String	RO
Status	1	"IOLM/Port 1/ISDU/Status"	ISDU read/write status	UInt32	RO
Index	1	"IOLM/Port 1/ISDU/Index"	ISDU index	UInt32	R / W
Subindex	1	"IOLM/Port 1/ISDU/Subindex"	ISDU subindex	UInt32	R / W
Request	1	"IOLM/Port 1/ISDU/Request"	ISDU read/write request	UInt32	R / W [2]
Data08	1	"IOLM/Port 1/ISDU/Data08"	ISDU data uint8	UInt8	R / W [2]
Data16	1	"IOLM/Port 1/ISDU/Data16"	ISDU data uint16	UInt16	R / W [2]
Data32	1	"IOLM/Port 1/ISDU/Data32"	ISDU data uint32	UInt32	R / W [2]
Data	1	"IOLM/Port 1/ISDU/Data"	ISDU data bytestring	Byte String	R / W [2]

[1] Allow OPC UA clients to write PDO data - must be enabled for the port to write PDO

[2] Allow OPC UA clients to write ISDU data - must be enabled to write ISDUs

[3] Allow OPC UA clients to write ISDU data - must be enabled to be visible and write ISDUs

[4] A write to a port that does not support Auxiliary Output will return UA_STATUSCODE_BADNOTWRITABLE error.

14.3. Functions

Node	Name space	Identifier (string)	Input Arguments	Output Arguments	Description
ISDU Read	1	"IOLM/Port 1/ISDU Read"	Index (UInt16) Subindex (Byte)	Read Data (ByteString)	Send an ISDU read request to the attached device
ISDU Write [3]	1	"IOLM/Port 1/ISDU Write"	Index (UInt16) Subindex (Byte)	Write Data (ByteString)	Send an ISDU write request to the attached device
Event Read	1	"IOLM/Port 1/Event Read"		Event Instance (Byte) Event Mode (Byte) Event Type (Byte) Event PDValid (Boolean) Event Local (Boolean) Event Code (UInt16) Event Description (String)	Read event from port's event queue
<p>[1] Allow OPC UA clients to write PDO data - must be enabled for the port to write PDO</p> <p>[2] Allow OPC UA clients to write ISDU data - must be enabled to write ISDUs</p> <p>[3] Allow OPC UA clients to write ISDU data - must be enabled to be visible and write ISDUs</p> <p>[4] A write to a port that does not support Auxiliary Output will return UA_STATUSCODE_BADNOTWRITABLE error.</p>					

15. MQTT Supporting Information

The following topics are discussed in the upcoming subsections:

- *Process Data Publish Interval* on Page 205
- *Topics and Payloads* on Page 206
- *ISDU Read/Write* on Page 210
- *ISDU Request Payload* on Page 211
- *ISDU Response Payload* on Page 211
- *PDO Write* on Page 214

15.1. Overview

MQTT support is available with application base 1.5.42 or higher and provides a way to publish various data to an MQTT broker. MQTT is a simple publish-subscribe messaging protocol that is becoming popular for use in Internet of Things (IoT) type applications:

- <http://mqtt.org/>
- <https://en.wikipedia.org/wiki/MQTT/>

The MQTT standard does not define any format for the published messages, but JSON has been almost universally adopted by the MQTT implementation in the IoT area, so JSON is the format chosen for use by the IO-Link master MQTT implementation.

Note: *All IO-Link master units are shipped from the factory with identical configurations. They all have the identical, self-signed, Pepperl+Fuchs Server RSA Certificates, Server RSA Keys, Server DH Keys, and no Client Authentication Certificates. For maximum data and access security, you should configure all IO-Link master units with custom certificates and keys.*

Refer to *MQTT Settings Configuration Page* on Page 99 for information about the MQTT Settings Configuration Page.

The screenshot shows the 'MQTT Settings' configuration page. At the top, there is a navigation menu with 'MQTT' highlighted. Below this is a table for 'MQTT PORT CONFIG' with columns for PORT 1 through PORT 8. Each port has an 'EDIT' button. The table contains the following data:

MQTT PORT CONFIG	PORT 1	PORT 2	PORT 3	PORT 4	PORT 5	PORT 6	PORT 7	PORT 8
Process Data Publish Interval Min (100 - 999999)	1000 ms	1000 ms	1000 ms	1000 ms	1000 ms	1000 ms	1000 ms	1000 ms
Process Data Publish Interval Max (0 - 999999)	0 s	0 s	0 s	0 s	0 s	0 s	0 s	0 s
PDO Write Enable	enable	disable	disable	disable	disable	disable	disable	disable

Below the table is the 'MQTT CONFIGURATION' section with the following fields:

- MQTT Client Enable:
- Server Name/IP:
- Server Port (0 - 65535):
- Use SSL/TLS:
- Server Authentication Certificate: No file selected.
- Verify Server Certificate Name:
- Client Certificate: No file selected.
- Client Private Key: No file selected.
- Username:
- Password:
- Client ID:
- Request Broker Retention:
- Publish Request QoS:
- Subscribe Request QoS:
- Topic Base Path:

At the bottom of the configuration section are 'CANCEL' and 'SAVE' buttons. The footer of the page shows 'Welcome Admin' and '© Pepperl+Fuchs'.

Note: MQTT is disabled by default.

15.2. Process Data Publish Interval

The PD Interval Min/Max configuration values control how often a PDI/PDO message is published. With the default configuration (min=1000ms max=0s), a value will be published when it has changed and at least 1 second has elapsed since the previous message was published. With max=0, a value will never be published unless it changes (except for once on startup).

If Interval Max is configured to a non-zero value, then PD messages will always be published after the configured interval even when the data is unchanged.

For example, with a configuration of min=5000ms max=60s, a changing value will only be published once every 5 seconds regardless of how often it changes, and a non-changing value will be published once every 60 seconds even when it has not changed.

15.3. Topics and Payloads

All published payloads are JSON objects. The initial set of published paths and data are listed below.

15.3.1 *MqttTopicBase/clientinfo*

A summary of information about the IO-Link master is published once each time the MQTT client starts. Example payload:

```
{
  "hostname" : "grant-ice2",
  "manufacturer" : "Pepperl-Fuchs Control, Inc.",
  "model" : "ICE2-8IOL-K45P-DIN",
  "serial" : "9710-000064",
  "version" : "EtherNet/IP 1.5.0.201",
  "numdioports" : 0,
  "numiolinkports" : 8
}
```

15.3.2 *MqttTopicBase/clientstatus*

A periodic message containing IO-Link master status is published under the "clientstatus" topic at a user-configured interval. The publishing period is user-configurable and can be disabled completely. An example payload is shown below.

```
{
  "uptime": 3464,
  "ports": [
    {
      "port": 1,
      "mode": "SIOInput",
      "status": "Operational",
      "state": "None",
      "pd_retries": 0,
      "pd_errors": 0,
      "pdi_valid": true,
      "pdo_valid": false
    },
    {
      "port": 2,
      "mode": "IOLinkInput",
      "status": "Operational",
      "state": "Operate",
      "pd_retries": 1,
      "pd_errors": 0,
      "pdi_valid": false,
      "pdo_valid": false
    },
    {
      "port": 3,
      "mode": "Reset",

```



```

    "status": "Inactive",
    "state": "None",
    "pd_retries": 0,
    "pd_errors": 0,
    "pdi_valid": true,
    "pdo_valid": false
  },
  ...
  {
    "port": 8,
    "mode": "IOLinkInput",
    "status": "Inactive",
    "state": "Init",
    "pd_retries": 0,
    "pd_errors": 0,
    "pdi_valid": true,
    "pdo_valid": false
  }
]
}

```

15.3.3.MqttTopicBase/port/n/deviceinfo

A port deviceinfo object is published each time the communication to an IO-Link device is established successfully. Example payloads:

```

{
  "port": 4,
  "vendorid": 1,
  "deviceid": 1120516,
  "functionid": 0,
  "vendname": "Pepperl+Fuchs",
  "vendtext": "www.pepperl-fuchs.com/io-link",
  "prodname": "OMT300-R200-2EP-IO-V1",
  "prodid": "295670-100140",
  "prodtext": "Distance sensor",
  "serial": "40000077249691",
  "hwvers": "HW01.00",
  "fwvers": "FW01.02",
  "apptag": "Your automation, our passion.",
  "functag": "R200 series",
  "loctag": "****",
  "pdibytes": 4,
  "pdobytes": 1,
  "isducapable": true,
  "dscapable": true,
  "dslength": 213,
  "iolinkvers": "11"
}

```



15.3.4.MqttTopicBase/port/n/status

A port status object is published on startup and each time the port changes state. Example payloads:

```
{
  "port":2,
  "mode":"IOLinkInput",
  "status":"Operational, PDI Valid",
  "state":"Operate"
}

{
  "port":5,
  "mode":"IOLinkInput",
  "status":"Inactive",
  "state":"Init"
}

{
  "port":3,
  "mode":"Reset",
  "status":"Inactive",
  "state":"None"
}

{
  "port":1,
  "mode":"SIOOutput",
  "status":"Operational",
  "state":"Reset"
}
```

15.3.5.MqttTopicBase/port/n/event

An event data object is published each time an event occurs for any port. Example payload:

```
{
  "port" : 1,
  "instance" : 3,
  "mode" : 1,
  "type" : 1,
  "pdvalid" : 0,
  "local" : 1,
  "code" : 36,
  "description" : "inst=AL mode=SINGLE type=MESSAGE pd=INVALID local=ff code=0x0024:M_PREOPERATE"
}
```

15.3.6. *MqttTopicBase/port/n/pdi*

PDI values are published when they change, Raw byte array data is always present. If PDI length is 4 or less, an unsigned integer version is also present. If an IODD file is present, dissected field values will be present for the configured process data group as defined by the IODD. If enabled, the process data field names will be "sanitized" so that they are legal JavaScript identifiers by replacing illegal characters with underscores.

Example payloads:

```
{
  "port" : 2,
  "valid" : 1,
  "uint" : 366,
  "raw" : [1,137]
}

{
  "port" : 4,
  "valid" : 1,
  "raw" : [9,124,9,79,9,127,0,0]
}

{
  "port": 1,
  "valid": 1,
  "V_PdT": {
    "Temperature": 0,
    "Switch status [OUT1].": 0
  },
  "raw": [9,140,9,136,9,90,0,0]
}

{
  "port": 1,
  "valid": 1,
  "V_PdT": {
    "Temperature": 0,
    "Switch_status__OUT1__": 0
  },
  "raw": [9,140,9,136,9,90,0,0]
}
```

15.3.7. *MqttTopicBase/port/n/pdo*

PDO values are published when they change (subject to the minimum publish interval setting) or periodically according to the maximum publish interval setting. Raw byte array data is always present. If PDO length is 4 or less, an unsigned integer version is also present. If an IODD file is present, dissected field values will be present for the configured process data group as defined by the IODD. If enabled, the process data field names will be "sanitized" so that they are legal Java-script identifiers by replacing illegal characters with underscores.

```
{
  "port" : 1,
  "valid" : 1,
  "uint" : 252,
  "raw" : [252]
}
```

15.3.8. *MqttTopicBase/port/n/auxin*

IO-Link port DI (auxilliary input) pin values will be published when they change (subject to minimum publish interval setting) or periodically according to the maximum publish interval setting. The payload comprises the port number and a single "value" field having an integer value of 0 or 1.

```
{
  "port": 2,
  "value": 0
}
```

15.4. ISDU Read/Write

Since MQTT lacks intrinsic support for request/response semantics, ISDU read/write requests and responses are handled via a pair of topics:

- *MqttTopicBase/port/n/isdu/request/client_transaction_id*
- *MqttTopicBase/port/n/isdu/response/client_transaction_id*

Requests for ISDU read/write are published by other clients to the "request" topic shown above. The *client_transaction_id* is an arbitrary string chosen by the requesting client and should be chosen to be unique. After the ISDU operation is completed, the IO-Link master will publish the response to the corresponding "response" topic (with the same *client_transaction_id* as the request).

15.5. ISDU Request Payload

The ISDU request payload is a JSON object with the fields described below.

Name	Type	Description
op	string	Required — must be "read" or "write"
index	integer	Required
subindex	integer	Optional (defaults to 0 if not provided)
<i>Fields specific to read requests:</i>		
format	string	Optional — if present, it determines the format of the returned read data in the response. Should be one of "str" "raw" "uint". If not provided, read data will be returned in all formats.
<i>Fields specific to write requests (exactly one of uint, raw, or str must be present):</i>		
raw	array	Array of integer byte values (decimal)
uint	integer	Integer data value (requires <i>len</i> field)
str	string	UTF-8 data string (<i>len</i> field is optional)
len	integer	Required for <i>uint</i> data, optional for <i>str</i> data. Controls number of data bytes written.

In a write request with *str* data and a *len* field, the string will be NULL-padded to the requested length before being written to the device.

15.6. ISDU Response Payload

The ISDU response payload is a JSON object with the fields described below:

Name	Type	Description
op	string	"op" value from request
index	integer	"index" value from request
subindex	integer	"subindex" value from request (if present and non-zero)
status	string	"OK" if the request was successful, otherwise an error message.
<i>Fields specific to read response (one or more of raw, str, uint may be present):</i>		
raw	array	Array of integer byte values (decimal)
uint	integer	Unsigned integer value
str	string	UTF-8 string data
len	integer	Number of bytes read

If no format is specified in the read request, then the read response will contain data in all three formats when *len* ≤ 4. If *len* > 4, only raw and str formats will be returned. If the read operation fails, no *len* value or data values will be returned.

In a read response, the *str* value will have any trailing NULL bytes removed. The *len* field will always indicate the total number of bytes read (including any trailing NULL bytes for string values)



Below is an example of a write-string request/response followed by a read-string request/response and a read-raw request/response where the topic base path is IOLM:

```
IOLM/port/1/isdu/request/66b127b7-f39d-40e7-b786-1cffc8d344a0
{
  "op": "write",
  "index": 24,
  "str": "hi there"
}
```

```
IOLM/port/1/isdu/response/66b127b7-f39d-40e7-b786-1cffc8d344a0
{
  PDO Write
  "op": "write",
  "index": 24,
  "status": "OK"
}
```

```
IOLM/port/1/isdu/request/2ee5141e-335b-4e33-bf4e-dedf01a0ff7b
{
  "op": "read",
  "index": 24,
  "format": "str"
}
```

```
IOLM/port/1/isdu/response/2ee5141e-335b-4e33-bf4e-dedf01a0ff7b
{
  "op": "read",
  "index": 24,
  "str": "hi there",
  "len": 16,
  "status": "OK"
}
```

```
IOLM/port/1/isdu/request/1c510d4d-151e-49b3-bbad-0847a272812e
{
  "op": "read",
  "index": 24,
  "format": "raw"
}
```

```
IOLM/port/1/isdu/response/1c510d4d-151e-49b3-bbad-0847a272812e
{
  "op": "read",
  "index": 24,
  "raw": [104,105,32,116,104,101,114,101,0,0,0,0,0,0,0],
  "len": 16,
  "status": "OK"
}
```

```
iolm1/port/3/isdu/request/1234
{
  "op": "read",
```

2022-12



```
"index": 15,  
"format": "str"  
}
```

iolm1/port/3/isdu/response/1234

Example: negative response 'Index not available'

```
{  
  "op": "read",  
  "index": 15,  
  "status": "Error",  
  "errmsg": "index invalid",  
  "errortype": {  
    "status": 1,  
    "code": 128,  
    "addcode": 17  
  }  
}
```

15.7. PDO Write

PDO values may be written by publishing to *MqttTopicBase/port/n/pdo/wr*. The payload may contain PDO data fields in one of two formats: raw or uint. Data in raw format must match the PDO length exactly. Data in uint format is supported only for PDO lengths of 4 bytes or less. If an IODD file is present that defines Process Data groups and fields, then those may be used to write to individual field values. The available groups/fields are shown on the MQTT diagnostics page as "PDGroups" in the MQTT Port Status table. The published object may also contain a boolean valid flag.

Example payloads:

```
IOLM/port/5/pdo/wr
{
  "uint": 349718
}
```

```
IOLM/port/1/pdo/wr
{
  "raw": [1,254,75]
}
```

```
IOLM/port/1/pdo/wr
{
  "uint": 15,
  "valid": true
}
```

```
IOLM/port/5/pdo/wr
{
  "raw": [1, 243,79,103, 253,12],
  "valid": true
}
```

```
IOLM/port/3/wr
{
  "PDOOut": {
    "LevelSetpoint": 119.34
  },
  "valid": true
}
```

```
IOLM/port/1/pdo/wr
{
  "valid": true
}
```

```
IOLM/port/8/pdo/wr
{
  "valid": false
}
```

16. Troubleshooting

This chapter provides the following information:

- *Troubleshooting*
- *IO-Link master LEDs* on Page 218
- *Using Log Files* on Page 225

16.1. Troubleshooting

Before contacting Technical Support, you may want to try the following:

- Check to make sure LEDs are not reporting an issue using *IO-Link master LEDs* on Page 218.
- Verify that the network IP address, subnet mask, and gateway are correct and appropriate for the network. Make sure that the IP address programmed into the IO-Link master matches the unique reserved IP configured address assigned by the system administrator.
 - If using DHCP, the host system needs to provide the subnet mask. The gateway is optional and is not required for a purely local network.
 - Remember that if the rotary switches on the ICE3-8IOL-G65L-V1D or ICE3-8IOL1-G65L-V1D are set to a non-default position, the rotary switches override the lower 3 digits (8 bits) of the static IP address configured in the **Network** page.
 - Verify that the Ethernet hub and any other network devices between the system and the IO-Link master are powered up and operating.
- Verify that you are using the correct types of cables on the correct connectors and that all cables are connected securely.
- Disconnect and re-connect the IO-Link device, or optionally, use the **Configuration | IO-Link** page to **Reset** the port, and then set the **Port Mode** back to **IO-Link**.
- Reboot or power cycle the IO-Link master. Use the **Advanced | Software** page to reboot the IO-Link master.
- Verify that the **Port Mode** matches the device, for example: IO-Link, Digital In, Digital Out, or Reset (port is disabled).
- If you are receiving an error that indicates a hardware fault, check the **Configuration | IO-Link** page for the port experiencing the fault.
 - Check the settings for the **Automatic Upload Enable** and **Automatic Download Enable** options. If the Vendor ID or Device ID of the attached device does not match, a hardware fault is generated.
 - Make sure if the port contains data storage that the Vendor ID and Device ID match the device attached to the port. If it does not, **CLEAR** the data storage or move the device to another port.
 - Check the Device Validation and Data Validation settings. If the attached device does not meet these settings, a hardware fault is issued.
- Open the IO-Link master web interface and review the following pages to see if you can locate a problem:
 - IO-Link Diagnostics
 - PROFINET IO Diagnostics
 - Modbus/TCP Diagnostics
 - OPC UA Diagnostics
 - MQTT Diagnostics

- ICE3-8IOL1-G65L-V1D only: Power Diagnostics
- If you have a spare IO-Link master, try replacing the IO-Link master.

16.2. IO-Link master LEDs

The following tables provide LED descriptions.

- ICE3-8IOL-G65L-V1D LEDs on Page 218
- ICE3-8IOL1-G65L-V1D LEDs on Page 220
- ICE3-8IOL-K45P-RJ45 LEDs on Page 223
- ICE3-8IOL-K45S-RJ45 LEDs on Page 224

16.2.1. ICE3-8IOL-G65L-V1D LEDs

The ICE3-8IOL-G65L-V1D (8-port IP67 model with an L-coded power connector) provides these LEDs.

LED Activity During Power On Sequence - ICE3-8IOL-G65L-V1D	
	<ol style="list-style-type: none"> 1. The US LED lights. 2. The ETH1/ETH2 LED lights on the connected port. 3. The MOD and NET LEDs are lit. 4. The IO-Link LEDs flash (if no IO-Link device attached) or are lit if an IO-Link device is attached. If a PLC is connected, the NET LED is lit and green.

ICE3-8IOL-G65L-V1D LEDs	
US	The US LED provides the following information: <ul style="list-style-type: none"> • Green solid = The IO-Link master is powered. • Red solid = Power input voltage below 18VDC.
UA	The UA LED provides the following information: <ul style="list-style-type: none"> • Green solid = The IO-Link master is powered. • Red solid = Power input voltage below 18VDC.
MOD (Module Status)	The MOD LED provides the following information: <ul style="list-style-type: none"> • Off = No errors • Red flashing = One or more errors detected • Red solid: <ul style="list-style-type: none"> - Maintenance required or demanded - Fatal error when NET is red solid.

ICE3-8IOL-G65L-V1D LEDs (Continued)	
NET (Network)	<p>The NET LED provides the following information:</p> <ul style="list-style-type: none"> • Off = No PLC connection • Green solid = PLC connection established • Red solid = Fatal error when MOD is also solid
ETH1/ ETH2	<p>The ETH1/ETH2 LEDs provide the following information:</p> <ul style="list-style-type: none"> • Green solid = Link • Green flashing = Activity
1 - 8 	<p>This LED provides the following information about the IO-Link port.</p> <ul style="list-style-type: none"> • Off = SIO mode - signal is low or disabled • Yellow = SIO mode - signal is high • Red flashing = Hardware fault - make sure that configured IO-Link settings on the port do not conflict with the device that is attached: <ul style="list-style-type: none"> - Automatic Upload and/or Download is enabled and it is not the same device. - Device Validation Mode is enabled and it is not the correct device. - Data Validation Mode is enabled but there is an error. • Solid red = PDI of the attached IO-Link device is invalid. • Green solid = An IO-Link device is connected and communicating • Green flashing = Searching for IO-Link devices
Port 1-8 DI	<p>The DI LED indicates auxiliary input on Pin 2.</p> <ul style="list-style-type: none"> • Of = DI signal is low or disconnected • Yellow = DI signal is high

16.2.2. ICE3-8IOL1-G65L-V1D LEDs

The ICE3-8IOL1-G65L-V1D (8-port IP67 model with an L-coded power connector and four Class B ports) provides these LEDs.

LED Activity During Power On Sequence - ICE3-8IOL1-G65L-V1D	
1.	The US LED lights.
2.	The PWR Out UA LED lights, if the Actuator Supply is valid. Note: <i>Actuator power (UA) is not required for the ICE3-8IOL1-G65L-V1D start-up but is required for Class B operation.</i>
3.	The ETH1/ETH2 LED lights on the connected port.
4.	The MOD and NET LEDs are lit.
5.	The IO-Link LEDs flash (if no IO-Link device attached) or are lit if an IO-Link device is attached. If a PLC is connected, the NET LED is lit and green.

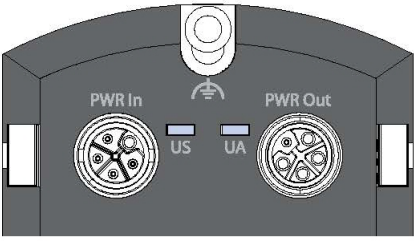
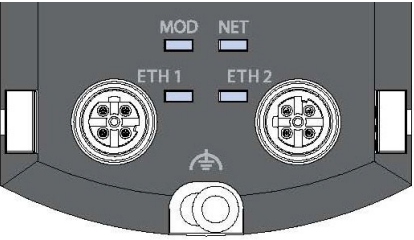
ICE3-8IOL1-G65L-V1D LEDs		
	US	The US LED provides the following information: <ul style="list-style-type: none"> Green solid = The IO-Link master is powered. Red solid = Power input voltage below 18VDC.
	UA	The UA LED provides the following information: <ul style="list-style-type: none"> Green solid = The IO-Link master is powered. Red solid = Power input voltage below 18VDC.
	MOD	The MOD (Module Status) LED provides the following information: <ul style="list-style-type: none"> Off = No errors Red flashing: One or more errors detected Red solid: <ul style="list-style-type: none"> Maintenance required or demanded Fatal error when NET is red solid
	NET	The NET LED provides the following information: <ul style="list-style-type: none"> Off = No PLC connection Green solid = PLC connection established Red solid = Fatal error when MOD is also red solid.
	ETH1/ETH2	The ETH1/ETH2 LEDs provide the following information: <ul style="list-style-type: none"> Green solid = Link Green flashing = Activity

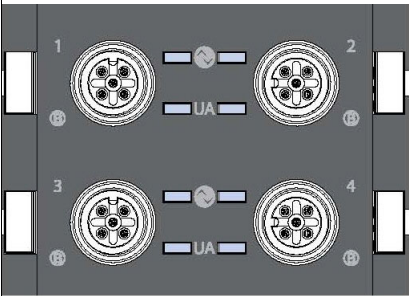
ICE3-8IOL1-G65L-V1D LEDs (Continued)		
<p>Ports 1 - 4</p>  <p>Class B</p>	<p>IO-Link</p>	<p>The IO-Link LED provides the following information about the IO-Link port.</p> <ul style="list-style-type: none"> • Off = SIO mode - signal is low or disabled • Yellow = SIO mode - signal is high • Red flashing = Hardware fault - make sure that configured IO-Link settings on the port do not conflict with the device that is attached: <ul style="list-style-type: none"> - Automatic Upload and/or Download is enabled and it is not the same device. - Device Validation Mode is enabled and it is not the correct device. - Data Validation Mode is enabled but there is an error. • Solid red = PDI of the attached IO-Link device is invalid. • Green solid = An IO-Link device is connected and communicating • Green flashing = Searching for IO-Link devices
	<p>UA</p>	<p>The UA LED indicates power supply output (U_A) through Pin 2.</p> <ul style="list-style-type: none"> • Green solid = UA power supply is turned on through Pin 2 • Red solid = Class B fault

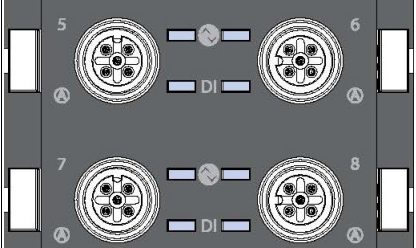
ICE3-8IOL1-G65L-V1D LEDs (Continued)		
<p>Ports 5 - 8</p>  <p>Class A</p>	<p>IO-Link</p>	<p>The IO-Link LED provides the following information about the IO-Link port.</p> <ul style="list-style-type: none"> • Off = SIO mode - signal is low or disabled • Yellow = SIO mode - signal is high • Red flashing = Hardware fault - make sure that configured IO-Link settings on the port do not conflict with the device that is attached: <ul style="list-style-type: none"> - Automatic Upload and/or Download is enabled and it is not the same device. - Device Validation Mode is enabled and it is not the correct device. - Data Validation Mode is enabled but there is an error. • Solid red = PDI of the attached IO-Link device is invalid • Green solid = An IO-Link device is connected and communicating • Green flashing = Searching for IO-Link devices
	<p>DI</p>	<p>When Pin 2 is used as a digital input:</p> <ul style="list-style-type: none"> • Off: DI signal is low or disconnected. • Yellow: DI signal is high <p>When Pin 2 is used as a digital output:</p> <ul style="list-style-type: none"> • Off: digital output is disabled (Pin 2 high impedance) • Yellow: digital output is enabled (Pin 2 high)

16.2.3. ICE3-8IOL-K45P-RJ45 LEDs

The ICE3-8IOL-K45P-RJ45 (8-port IP20 DIN rail model with pluggable, removable connectors) provides these LEDs.

LED Activity During Power On Sequence - ICE3-8IOL-K45P-RJ45

1. The **E1/E2** LED lights on the connected port.
2. The **MOD** and **NET** LEDs are lit.
3. The IO-Link LEDs flash (if no IO-Link device attached) or are lit if an IO-Link device is attached. If a PLC is connected, the **NET** LED is lit and green.

ICE3-8IOL-K45P-RJ45 LEDs

MOD (Module Status)	<p>The MOD LED provides the following information:</p> <ul style="list-style-type: none"> • Off = No errors • Red flashing = One or more errors detected • Red solid: <ul style="list-style-type: none"> - Maintenance required or demanded - Fatal error when NET is red solid.
NET (Network)	<p>The NET LED provides the following information:</p> <ul style="list-style-type: none"> • Off = No PLC connection • Green solid = PLC connection established • Red solid = Fatal error when MOD is also solid
Port 1-8	<p>This LED provides the following information about the IO-Link port.</p> <ul style="list-style-type: none"> • Of = SIO mode - signal is low or disabled • Yellow = SIO mode - signal is high • Red flashing = Hardware fault - make sure that configured IO-Link settings on the port do not conflict with the device that is attached: <ul style="list-style-type: none"> - Automatic Upload and/or Download is enabled and it is not the same device. - Device Validation Mode is enabled and it is not the correct device. - Data Validation Mode is enabled but there is an error. • Red solid = PDI of the attached IO-Link device is invalid. • Green solid = An IO-Link device is connected and communicating • Green flashing = Searching for IO-Link devices
Port 1-8 DI	<p>The DI LED indicates digital input on Pin 3.</p> <ul style="list-style-type: none"> • Off = DI signal is low or disconnected • Yellow = DI signal is high
Dual Ethernet Ports	<p>The Ethernet LEDs provide the following information:</p> <ul style="list-style-type: none"> • Green solid = Link • Yellow solid = Activity

16.2.4. ICE3-8IOL-K45S-RJ45 LEDs

The ICE3-8IOL-K45S-RJ45 (8-port IP20 DIN rail model with pluggable, removable connectors) provides these LEDs.

LED Activity During Power On Sequence - ICE3-8IOL-K45S-RJ45

1. The **E1/E2** LED lights on the connected port.
2. The **MOD** and **NET** LEDs are lit.
3. The IO-Link LEDs flash (if no IO-Link device attached) or are lit if an IO-Link device is attached. If a PLC is connected, the **NET** LED is lit and green.

ICE3-8IOL-K45S-RJ45 LEDs

MOD (Module Status)	<p>The MOD LED provides the following information:</p> <ul style="list-style-type: none"> • Off = No errors • Red flashing = One or more errors detected • Red solid: <ul style="list-style-type: none"> - Maintenance required or demanded - Fatal error when NET is red solid.
NET (Network)	<p>The NET LED provides the following information:</p> <ul style="list-style-type: none"> • Off = No PLC connection • Green solid = PLC connection established • Red solid = Fatal error when MOD is also solid
Port 1-8	<p>This LED provides the following information about the IO-Link port.</p> <ul style="list-style-type: none"> • Of = SIO mode - signal is low or disabled • Yellow = SIO mode - signal is high • Red flashing = Hardware fault - make sure that configured IO-Link settings on the port do not conflict with the device that is attached: <ul style="list-style-type: none"> - Automatic Upload and/or Download is enabled and it is not the same device. - Device Validation Mode is enabled and it is not the correct device. - Data Validation Mode is enabled but there is an error. • Red solid = PDI of the attached IO-Link device is invalid. • Green solid = An IO-Link device is connected and communicating • Green flashing = Searching for IO-Link devices
Port 1-8 DI	<p>The DI LED indicates digital input on Pin 3.</p> <ul style="list-style-type: none"> • Off = DI signal is low or disconnected • Yellow = DI signal is high
Dual Ethernet Ports	<p>The Ethernet LEDs provide the following information:</p> <ul style="list-style-type: none"> • Green solid = Link • Yellow solid = Activity



16.3. Using Log Files

The IO-Link master provides different log files that you can view, export, or clear:

- **syslog** (system log) displays line-by-line activity records
- **dmesg** displays Linux kernel messages
- **top** displays which programs are using most of the memory and CPU
- **ps** displays the running programs
- **opcua** displays OPC UA activity
- **mqtt** displays MQTT activity
- **pnio** displays PROFINET IO activity

All log files start up automatically during the startup cycle. Each log file has a size limit of 100KB.

Note: Typically, log files are intended to be used by Technical Support in the event there is a problem.

You can use the following procedures to:

- *View a Log File*
- *Clear a Log File on Page 227*
- *Export a Log File on Page 226*

16.3.1. View a Log File

Use this procedure to view a log file.

1. Open your browser and enter the IP address of the IO-Link master.
2. Click **Advanced** and then **LOG FILES**.
3. Select the log file type from the drop-list.

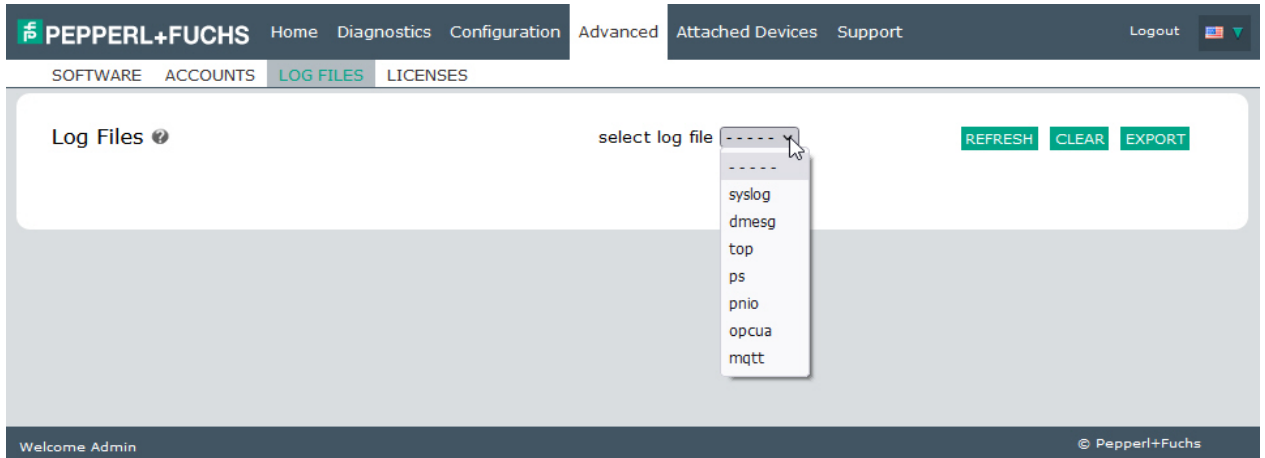

4. Optionally, click the **REFRESH** button to get the latest information.
5. Optionally, export the log file.

16.3.2. Export a Log File

Use the following procedure to export a log file.

1. Open your browser and enter the IP address of the IO-Link master.
2. Click **Advanced** and then **LOG FILES**.
3. Select the log file type from the drop-list.
4. Click the **EXPORT** button.

- Click the **Save** button drop-list and click **Save** to save it to your user folder or **Save as** to browse to or create a new folder in which to place the log file.

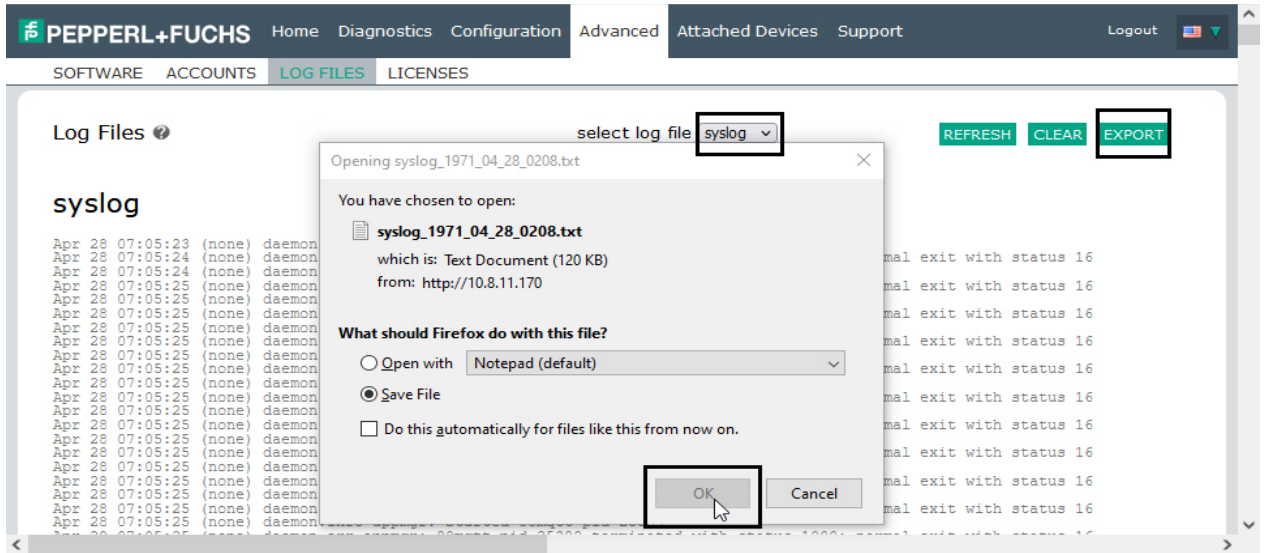

- Depending on your browser, you may need to close the pop-up window.

16.3.3. Clear a Log File

Use this procedure to clear a log file.

- Open your browser and enter the IP address of the IO-Link master.
- Click **Advanced** and then **LOG FILES**.
- Optionally, export the log file.
- Select the log file type from the drop-list.
- Click the **CLEAR** button.

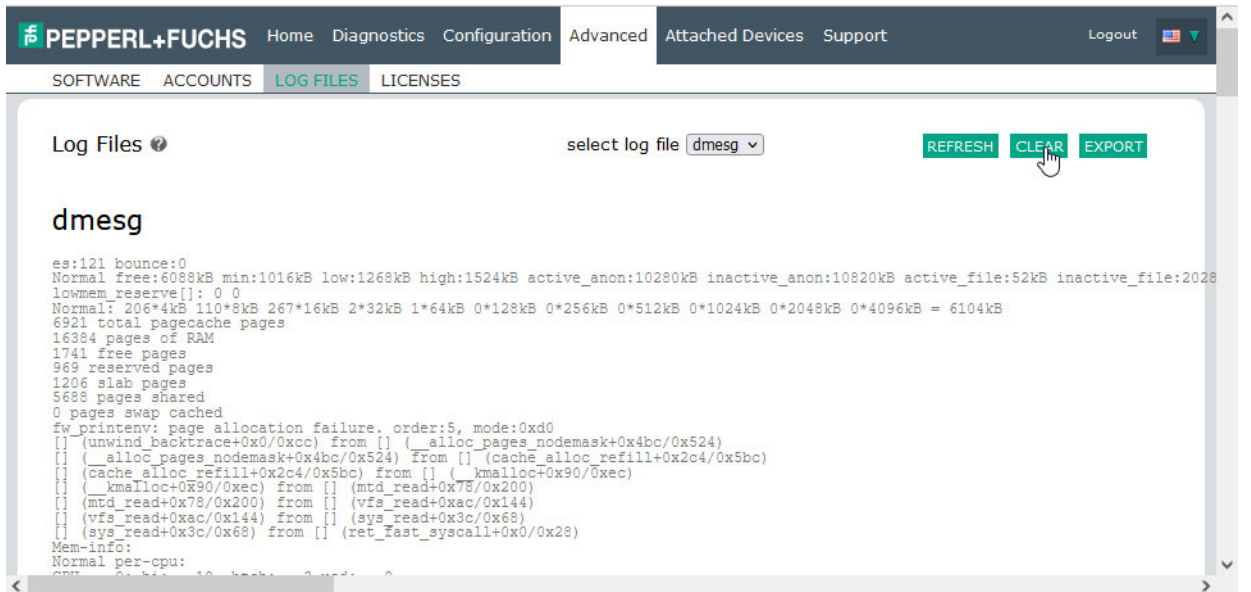



The log file automatically starts logging the latest information.

FACTORY AUTOMATION – SENSING YOUR NEEDS



Worldwide Headquarters

Pepperl+Fuchs Group
68307 Mannheim · Germany
Tel. +49 621 776-0
E-mail: info@de.pepperl-fuchs.com

USA Headquarters

Pepperl+Fuchs Inc.
Twinsburg, Ohio 44087 · USA
Tel. +1 330 4253555
E-mail: sales@us.pepperl-fuchs.com

Asia Pacific Headquarters

Pepperl+Fuchs Pte Ltd.
Company Registration No. 199003130E
Singapore 139942
Tel. +65 67799091
E-mail: sales@sg.pepperl-fuchs.com

www.pepperl-fuchs.com

 **PEPPERL+FUCHS**
SENSING YOUR NEEDS

Subject to modifications
Copyright PEPPERL+FUCHS • Printed in Germany

DOCT-6418

2022-12