

MANUAL

USB Intrinsic Safety Barrier SK-PC-D2-UU1-10-HS



With regard to the supply of products, the current issue of the following document is applicable: The General Terms of Delivery for Products and Services of the Electrical Industry, published by the Central Association of the Electrical Industry (Zentralverband Elektrotechnik und Elektroindustrie (ZVEI) e.V.) in its most recent version as well as the supplementary clause: "Expanded reservation of proprietorship"

1	Introduction	4
1.1	Content of this Document	4
1.2	Target Group, Personnel.....	4
1.3	Symbols Used	5
2	Product Description	6
2.1	Intended Use and Function.....	6
2.2	Technical Data	7
2.3	Dimensions.....	9
2.4	Transport, Storage, and Maintenance.....	9
2.5	Disposal	9
3	Installation and Commissioning	10
3.1	General Installation Requirements	10
3.2	Intrinsically Safe Wiring and Cable Parameters	10
3.3	Wiring and Grounding the Barrier with EXTA3 and Host.....	11
3.4	Wiring and Grounding the Barrier via Terminal 16	12
3.5	Connections	13
4	Appendix	14
4.1	Accessories.....	14



1 Introduction

1.1 Content of this Document

This document contains information that you need in order to use your product throughout the applicable stages of the product life cycle. These can include the following:

- Product identification
- Delivery, transport, and storage
- Mounting and installation
- Commissioning and operation
- Maintenance and repair
- Troubleshooting
- Dismounting
- Disposal



Note!

This document does not substitute the instruction manual.



Note!

For full information on the product, refer to the instruction manual and further documentation on the Internet at www.pepperl-fuchs.com.

The documentation consists of the following parts:

- Present document
- Instruction manual
- Datasheet

Additionally, the following parts may belong to the documentation, if applicable:

- EU-type examination certificate
- EU declaration of conformity
- Attestation of conformity
- Certificates
- Control drawings
- Additional documents

1.2 Target Group, Personnel

Responsibility for planning, assembly, commissioning, operation, maintenance, and dismounting lies with the plant operator.

Only appropriately trained and qualified personnel may carry out mounting, installation, commissioning, operation, maintenance, and dismounting of the product. The personnel must have read and understood the instruction manual and the further documentation.

Prior to using the product make yourself familiar with it. Read the document carefully.

1.3 Symbols Used

This document contains symbols for the identification of warning messages and of informative messages.

Warning Messages

You will find warning messages, whenever dangers may arise from your actions. It is mandatory that you observe these warning messages for your personal safety and in order to avoid property damage.

Depending on the risk level, the warning messages are displayed in descending order as follows:



Danger!

This symbol indicates an imminent danger.

Non-observance will result in personal injury or death.



Warning!

This symbol indicates a possible fault or danger.

Non-observance may cause personal injury or serious property damage.



Caution!

This symbol indicates a possible fault.

Non-observance could interrupt the device and any connected systems and plants, or result in their complete failure.

Informative Symbols



Note!

This symbol brings important information to your attention.



Action

This symbol indicates a paragraph with instructions. You are prompted to perform an action or a sequence of actions.

2 Product Description

2.1 Intended Use and Function



The SK-PC-D2-UU1-10-HS USB intrinsic safety barrier enables a host device (i.e., an industrial PC) that is in a non-explosion hazardous environment to be connected to an EXTA3 keyboard or similar USB device in Class I/Div. 2, Class II/Div 2, or ATEX/IECEX Zone 2/22 hazardous locations. The barrier is based on the entity concept and enables operation of input devices, such as PC keyboards and trackballs. The barrier provides protected USB 1.1 or PS2 power and data signals to an Ex-rated mouse/keyboard in the field.

The barrier shall be installed according to all applicable standards and regulations for the location in which it is being installed. The barrier is intended to be mounted on a 35mm DIN rail within a properly rated equipment cabinet for the application area. When installed under ATEX/IECEX, the barrier shall be in an ATEX/IECEX certified enclosure with a minimum ingress protection rating of IP54. The barrier shall be used in an environment of not more than pollution degree 2. This device contains no user serviceable components. Replacing internal components may impair the safety of the device.



2.2

Technical Data

SK-PC-D2-UU1-10-HS	
Supply	
Rated voltage	9 ... 30 VDC (Um = 30 V SELV)
Input current	120 mA nominal 500 mA max
Indicators/operating means	
LED ON	power - keyboard power - mouse
Interface	
Interface type	USB 1.1 or PS2
Output	
Output rated operating current	89 mA
Output voltage	4.8 VDC
Directive conformity	
Electromagnetic compatibility	
Directive 2014/30/EU	EN 61326-1:2013 (industrial locations)
RoHS	
Directive 2011/65/EU (RoHS)	EN 50581:2012-09
Conformity	
Degree of protection	IEC 60529
Protection against electrical shock	IEC 61140
Ambient conditions	
Ambient temperature	-40 ... 60 °C (-40 ... 140 °F)
Relative humidity	0 ... 95% (noncondensing)
Vibration resistance	5 G, 58 ... 150 Hz
Impact resistance	15 g, 11 ms
Mechanical specifications	
Connection type	Terminal Block
Degree of protection	IP20
Connection	Supply: terminals 13+, 14- Input: terminals 9+, 10-; 11+, 12- Output: terminals 1+, 2+, 3-, 4-; 5+, 6+, 7-, 8- (field terminal) Ground: terminals 15, 16
Mass	120 g
Dimensions	99 mm x 85 mm x 22.5 mm
Cable length	4.6 m (15'): barrier to keyboard/mouse 4.6 m (15'): host pc to keyboard/mouse 6.1 m (20'): total length, host PC to keyboard/mouse
Data for application in connection with hazardous areas	
EU-type examination certificate	DEMKO 14ATEX1269806X
Marking	 II 3 G Ex nA [ic] IIC T6 Gc  II 3 G Ex nA [ic IIIB] IIC T6 Gc

2019-06

	SK-PC-D2-UU1-10-HS
Directive conformity	
Directive 2014/34/EU	EN 60079-0:2012+A11:2013 , EN 60079-11:2012 , EN 60079-15:2010
International approvals	
UL approval	cULus (E106378)
Control drawing	116-0337
Approved for	Mountable in Class I, Division 2, Groups A, B, C, D Providing non-incendive field wiring at field terminals to Class I, Division 2, Groups A, B, C, D Class II, Division 2, Groups F, G Class III, Division 2 Temperature Class T6 Mountable in Class I, Zone 2 Providing intrinsic safety wiring at field terminals for Class I, Zone 2, Group IIC and Group IIIB hazardous locations USL: Class I, Zone 2 AEx nA [ic] IIC T6 Gc Class I, Zone 2 AEx nA [ic IIIB] IIC T6 Gc CNL: Class I, Zone 2, Ex nA [ic] IIC T6 Gc X Class I, Zone 2, Ex nA [ic IIIB] IIC T6 Gc X
IECEX approval	IECEX UL 14.0017X
Approved for	Ex nA [ic] IIC T6 Gc Ex nA [ic IIIB] IIC T6 Gc
Standards	IEC 60079-0:2011 (6th edition) IEC 60079-11:2011 (6th edition) IEC 60079-15:2010 (4th edition)
Pluggable terminal blocks	
Conductor size	0.2 mm ² (24 AWG) to 2.5 mm ² (12 AWG)
Conductor insulation	Must be rated 65 °C or higher
Tightening torque	0.5 Nm (4.4 in-lb) to 0.6 Nm (5.3 in-lb)



Warning!

Maximum prospective current

Limit the external maximum prospective current to 50 A.

2.3 Dimensions

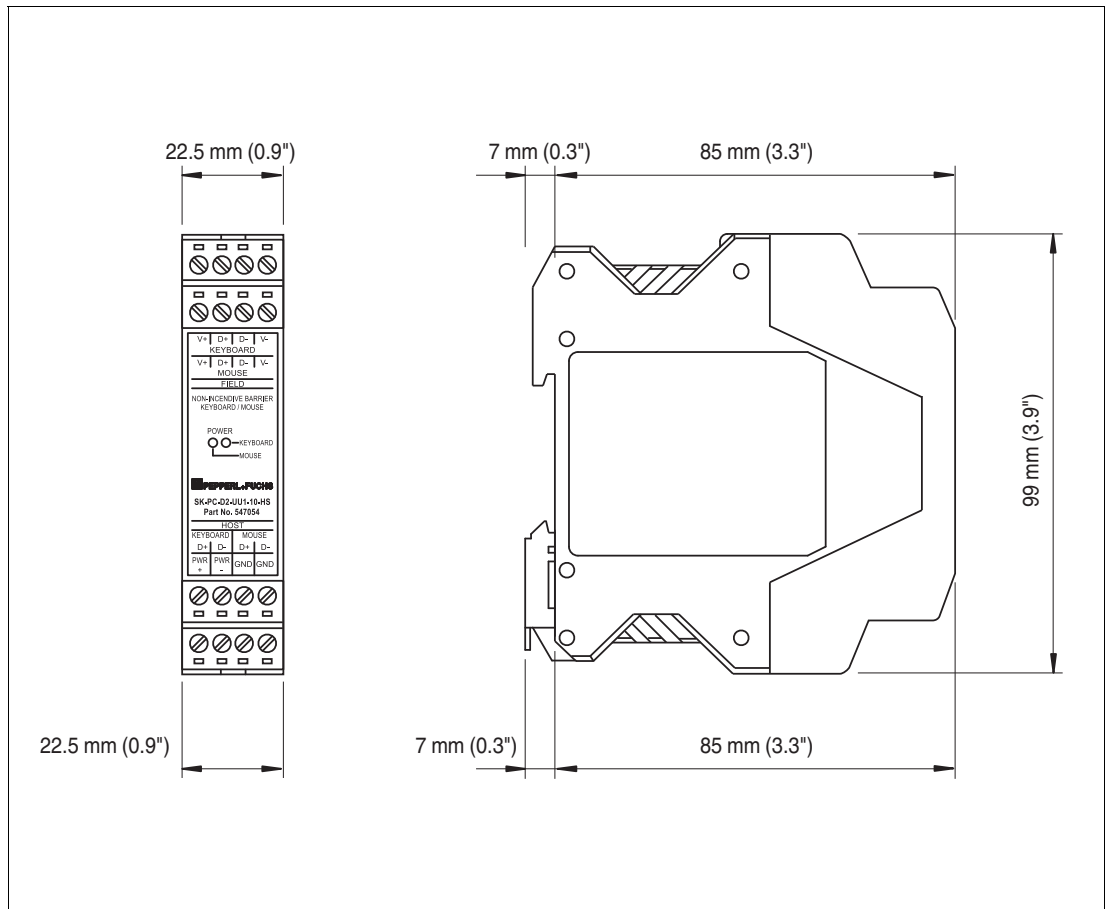

2.4 Transport, Storage, and Maintenance

In case of defect, the device must be removed and replaced with a new one. Store all devices in a clean and dry environment.

2.5 Disposal

Disposal of devices and their packaging material must be performed in compliance with the applicable laws and guidelines of the corresponding country. The devices do not contain batteries that need to be disposed separately from the products.



3 Installation and Commissioning

3.1 General Installation Requirements

Devices being operated in connection with hazardous areas may not be changed or manipulated. If there is a defect, the product must always be replaced with an original part. If devices have been operated in general electrical systems, they must not subsequently be operated in electrical systems related to explosive areas. The installation of the intrinsically safe circuits has to be conducted in accordance with the relevant installation regulations, particularly IEC/EN 60079-14.

The device must be mounted in the non-explosive hazardous area.

If Intrinsically safe circuits are connected to earth, there must exist equipotential bonding along the intrinsically safe circuits.

3.2 Intrinsically Safe Wiring and Cable Parameters

Only use cables that meet the requirements of IEC/EN 60079-14 to connect to the terminals on the barrier. The cable length from the barrier to the keyboard/mouse and from the barrier to the host PC should not exceed 4.6 m. The total cable length should not exceed 6.1 m.

Wiring Information

Field terminals 1 ... 4 and 5 ... 8 are for connection to a USB or PS2 keyboard or mouse with proper matching entity parameters. Connections 9 ... 12 are the host side USB/PS2 data signal connections. These match the common named field connections (D+ D- keyboard are the datalines to the keyboard connections on the field side, etc.). 13 and 14 are for connection to a properly rated SELV supply voltage. Connections 15 and 16 are to be connected to ground. By connecting the host USB cables, the connections 4, 8, 12, 14, 15, and 16 are grounded via the host PC. The precondition for this is that the GND line of the PC USB connection is internally connected to ground. This must be ensured by measurement.

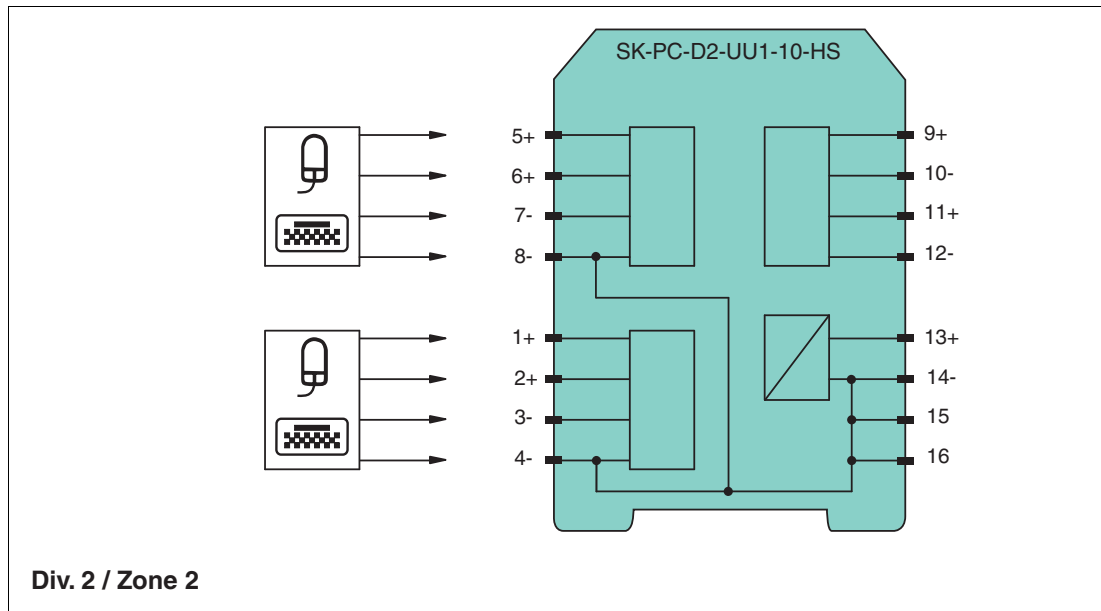

Wire from the EXTA3 keyboard into the SK-PC-D2-UU1-10-HS keyboard barrier. Connect the keyboard and mouse as indicated below.

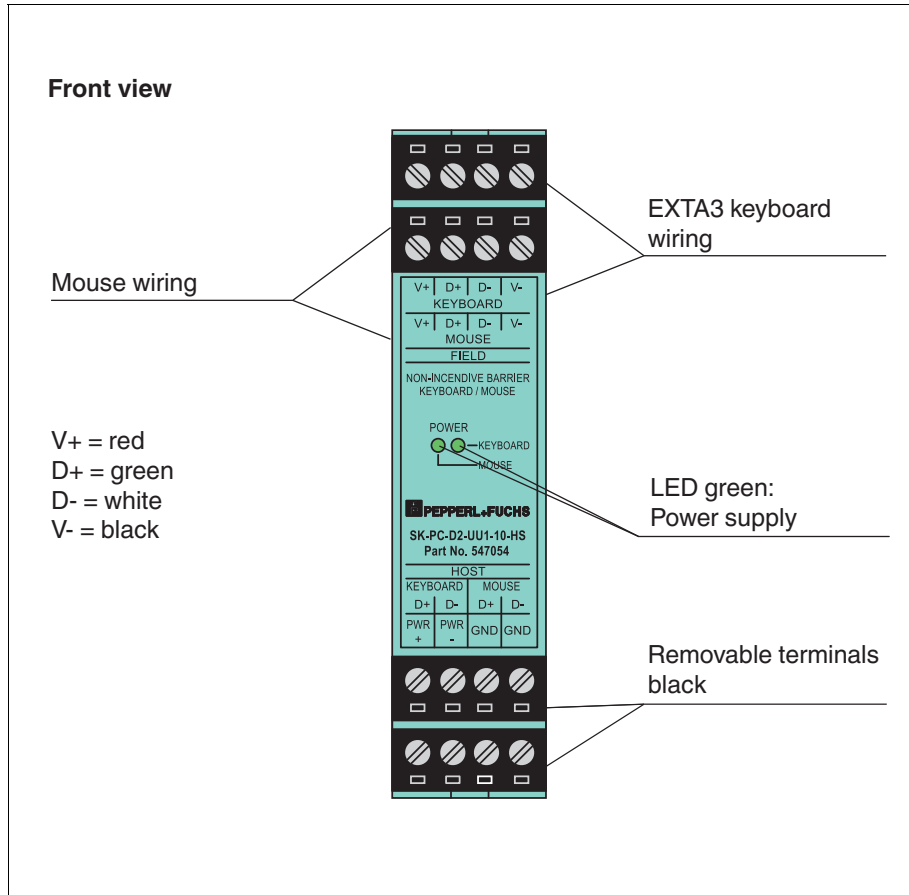

3.3 Wiring and Grounding the Barrier with EXTA3 and Host

Wire the SK-PC-D2-UU1-10-HS barrier to the host PC as follows:

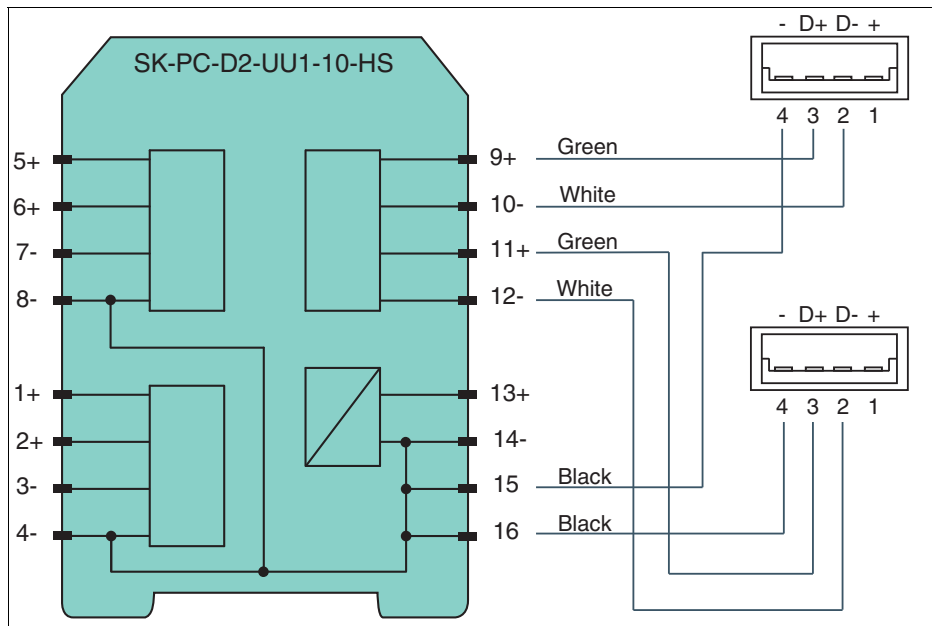

Grounding is executed via the host PC. The precondition for this is that the GND line of the PC USB connection is internally connected to ground. This must be ensured by measurement.



3.4 Wiring and Grounding the Barrier via Terminal 16

Grounding is executed via terminal 16. In common application scenarios, pins number 4 (minus wires) of the host USB connectors are connected within the host. If not, connect pins 4 together to terminal 15:

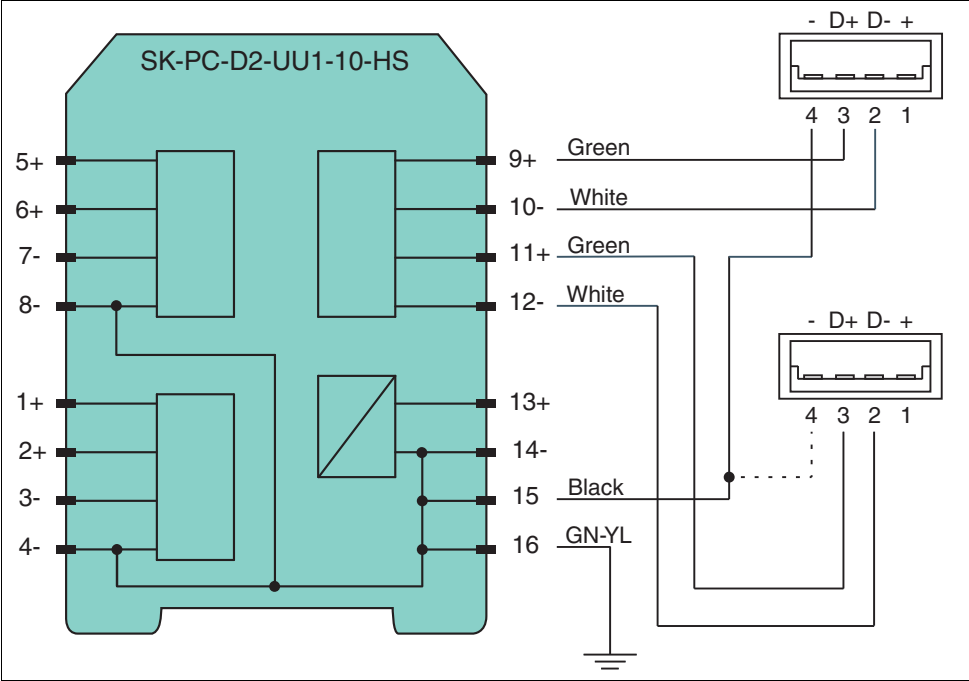

3.5 Connections

Inputs from Host

Connector	Terminal	Signal Name	Direction	Color Coding
Input 1 (Host)	9+	D+	I/O	Green
	10-	D-	I/O	White
Input 2 (Host)	11+	D+	I/O	Green
	12-	D-	I/O	White
Supply	13+	PWR+	Supply	
	14-	PWR-	Supply	
Input 1 (host)	15	GND	Supply	Black (ground from host)
Input 2 (host)	16	GND	Supply	Black (ground from host)

Outputs to Field Devices

Connector	Terminal	Signal Name	Direction	Color Coding
Output 1 (Field) (Keyboard)	1+	V+	Supply	Green
	2+	D+	I/O	Brown
	3-	D-	I/O	Gray
	4-	V-	Supply	Yellow
Output 2 (Field) (Mouse)	5+	V+	Supply	Red
	6+	D+	I/O	White
	7-	D-	I/O	Pink
	8-	V-	Supply	Blue

End of the Keyboard Cable (Attached to the Keyboard)

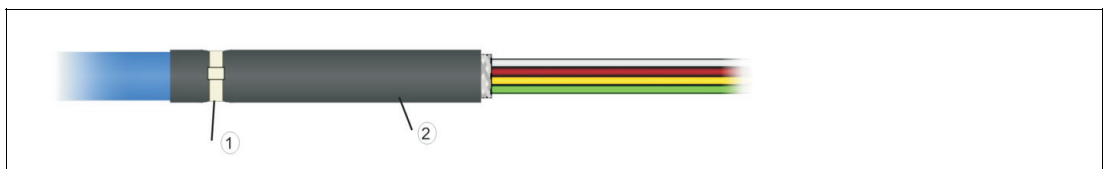

- (1) cable clip
- (2) protective tube



4

Appendix

4.1

Accessories

Item Number	Name	Description
Contact sales for individual configuration	EXTA 3 product family	Keyboard and mouse system—stand-alone option for Zone 2/22

PROCESS AUTOMATION – PROTECTING YOUR PROCESS



Worldwide Headquarters

Pepperl+Fuchs GmbH
68307 Mannheim · Germany
Tel. +49 621 776-0
E-mail: info@de.pepperl-fuchs.com

For the Pepperl+Fuchs representative
closest to you check www.pepperl-fuchs.com/contact

www.pepperl-fuchs.com

 **PEPPERL+FUCHS**
PROTECTING YOUR PROCESS

Subject to modifications
Copyright PEPPERL+FUCHS • Printed in Germany

/ DOCT-6424
06/2019