

WCS-ECG410

Interface Module EtherCAT

Manual

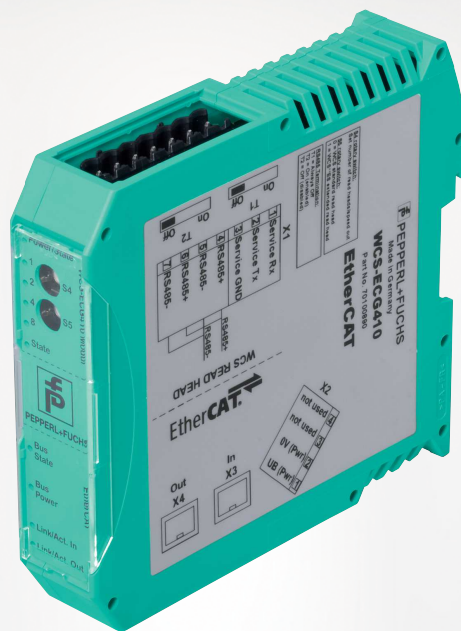

EtherCAT 

Your automation, our passion.

 **PEPPERL+FUCHS**

With regard to the supply of products, the current issue of the following document is applicable: The General Terms of Delivery for Products and Services of the Electrical Industry, published by the Central Association of the Electrical Industry (Zentralverband Elektrotechnik und Elektroindustrie (ZVEI) e.V.) in its most recent version as well as the supplementary clause: "Expanded reservation of proprietorship"

Worldwide

Pepperl+Fuchs Group
Lilienthalstr. 200
68307 Mannheim
Germany
Phone: +49 621 776 - 0
E-mail: info@de.pepperl-fuchs.com

North American Headquarters

Pepperl+Fuchs Inc.
1600 Enterprise Parkway
Twinsburg, Ohio 44087
USA
Phone: +1 330 425-3555
E-mail: sales@us.pepperl-fuchs.com

Asia Headquarters

Pepperl+Fuchs Pte. Ltd.
P+F Building
18 Ayer Rajah Crescent
Singapore 139942
Phone: +65 6779-9091
E-mail: sales@sg.pepperl-fuchs.com
<https://www.pepperl-fuchs.com>

1	Introduction.....	4
1.1	Content of this Document.....	4
1.2	Target Group, Personnel	4
1.3	Symbols Used	4
2	Product description.....	6
2.1	Use and Application	6
2.2	Dimensions.....	6
2.3	Design of the Device.....	7
3	Installation.....	11
3.1	Mounting.....	11
3.2	Electrical Connection	12
3.3	Dismounting.....	14
4	Commissioning.....	15
4.1	Introduction	15
4.2	Connecting the WCS Read Head.....	16
4.3	Connection to the Network	18
4.4	Integrate Interface Module into the Network	19
4.5	Data Format for Modules	22
5	Communication with WCS read heads	24
5.1	Data Protocols	24
5.2	Option-E—Extended, Type WCS3B-LS2*E*, RS-485	27
6	Appendix	30
6.1	Cable Routing in the RS-485 Bus	30
6.2	Data Cable	32

1 Introduction

1.1 Content of this Document

This document contains information required to use the product in the relevant phases of the product life cycle. This may include information on the following:

- Product identification
- Delivery, transport, and storage
- Mounting and installation
- Commissioning and operation
- Maintenance and repair
- Troubleshooting
- Dismounting
- Disposal



Note

For full information on the product, refer to the further documentation on the Internet at www.pepperl-fuchs.com.

The documentation comprises the following parts:

- This document
- Datasheet

In addition, the documentation may comprise the following parts, if applicable:

- EU-type examination certificate
- EU declaration of conformity
- Attestation of conformity
- Certificates
- Control drawings
- Instruction manual
- Other documents

1.2 Target Group, Personnel

Responsibility for planning, assembly, commissioning, operation, maintenance, and dismounting lies with the plant operator.

Only appropriately trained and qualified personnel may carry out mounting, installation, commissioning, operation, maintenance, and dismounting of the product. The personnel must have read and understood the instruction manual and the further documentation.

Prior to using the product make yourself familiar with it. Read the document carefully.

1.3 Symbols Used

This document contains symbols for the identification of warning messages and of informative messages.

Warning Messages

You will find warning messages, whenever dangers may arise from your actions. It is mandatory that you observe these warning messages for your personal safety and in order to avoid property damage.

Depending on the risk level, the warning messages are displayed in descending order as follows:



Danger!

This symbol indicates an imminent danger.

Non-observance will result in personal injury or death.



Warning!

This symbol indicates a possible fault or danger.

Non-observance may cause personal injury or serious property damage.



Caution!

This symbol indicates a possible fault.

Non-observance could interrupt the device and any connected systems and plants, or result in their complete failure.

Informative Symbols



Note

This symbol brings important information to your attention.



Action

This symbol indicates a paragraph with instructions. You are prompted to perform an action or a sequence of actions.

2 Product Description

2.1 Use and Application

The WCS-ECG410 interface module acts as an interface between the WCS read head and the EtherCAT controller. The device has two EtherCAT ports. Data is transferred between the WCS read head or WCS read heads and the interface module via the RS-485 interface and from the interface module to the controller via the EtherCAT protocol.

You can connect up to four LS221 or LS121 WCS read heads. If you connect several read heads, they must have different addresses. The number of connected read heads is configured in the hardware project planning.

The interface module supports the operation of read heads with the Extended option (WCS3B-LS*E*), with distances of up to 629 meters.

2.2 Dimensions

The interface module housing has the following dimensions.

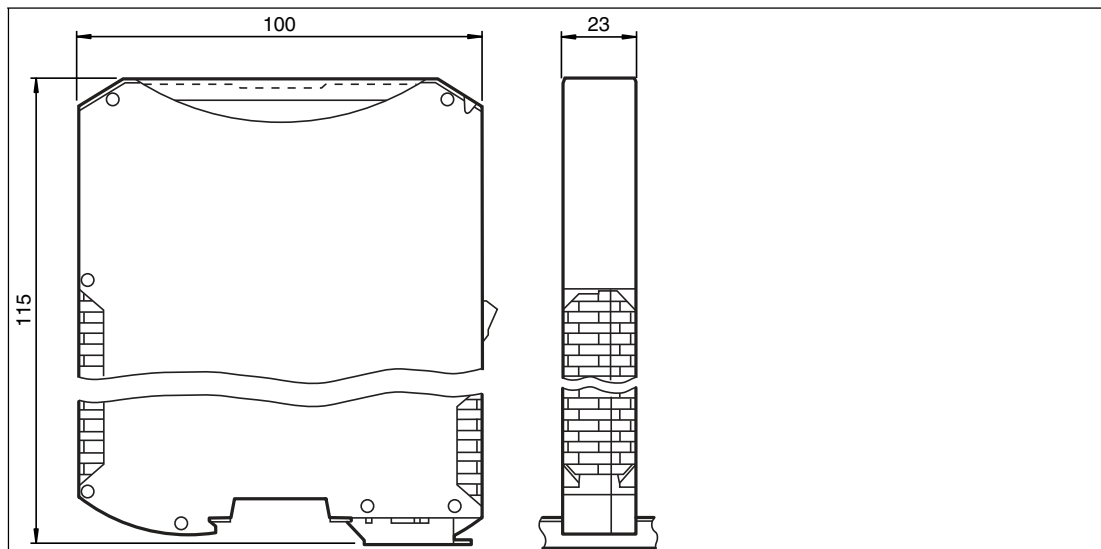

Figure 2.1 Dimensions

2.3 Design of the Device

Device Components

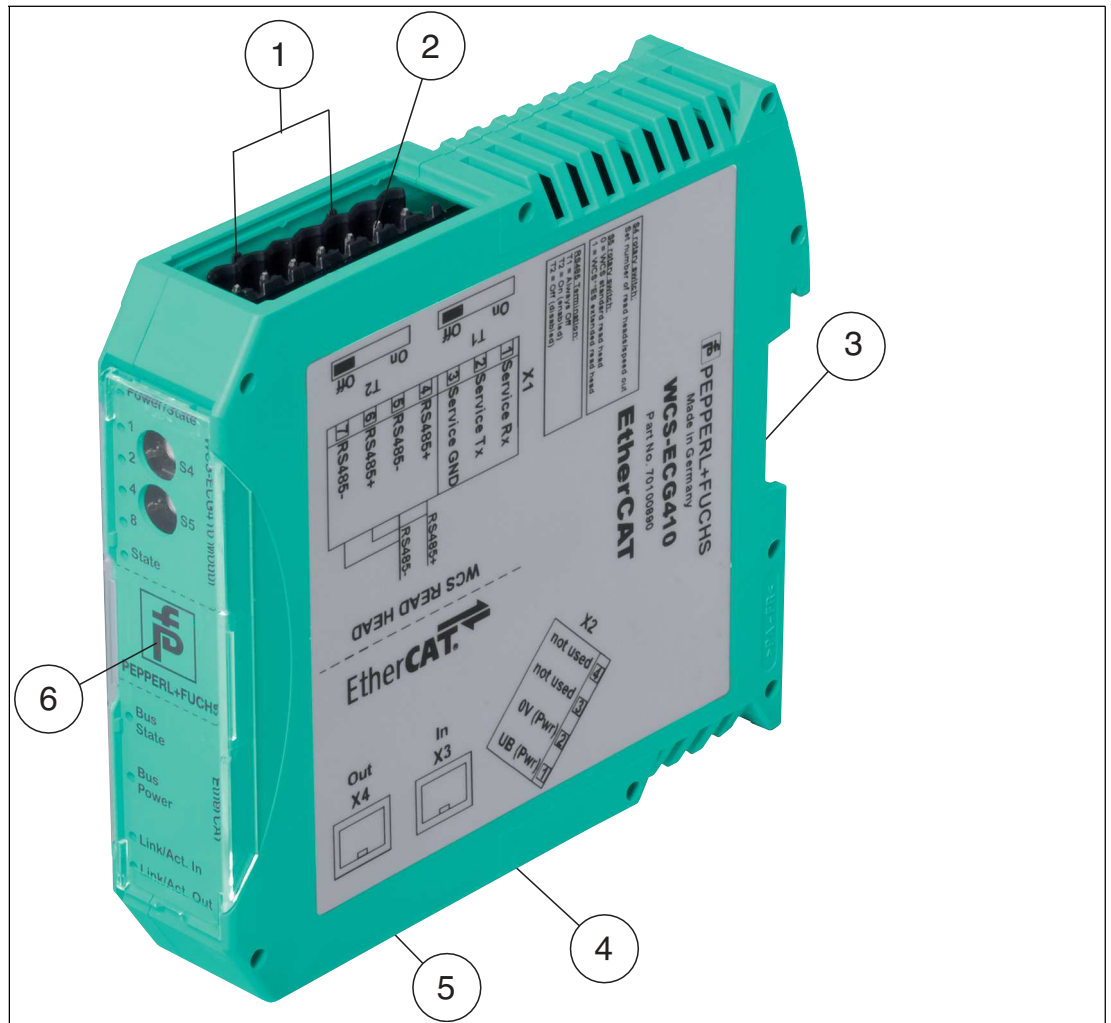

Figure 2.2 Interface module overview

- 1 RS-485 bus termination slide switch
- 2 X1: RS-485 interface
- 3 Mounting bracket
- 4 X2: Connection for power supply
- 5 X3: EtherCAT communication interface
- 6 Front panel with rotary coding switch and LED status indicator

Front Panel

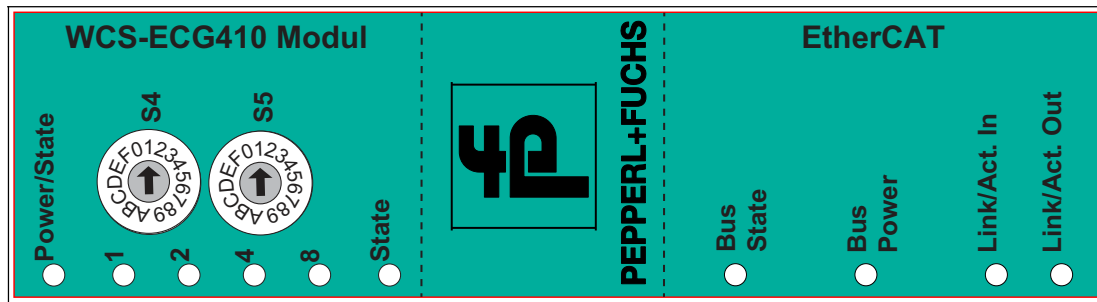

Figure 2.3 Front panel overview

WCS read head: LED status indicator and rotary coding switch

Power:

The "Power" LED lights up green: power supply is present.

State:

The "State" LED is green: Data is being exchanged with the WCS read heads. The four "Error No/Select ID" LEDs are used to display the number of the currently polled WCS read head.

Error No/Select ID				Read head address
8	4	2	1	
0	0	0	1	0
0	0	1	0	1
0	1	0	0	2
1	0	0	0	3

Table 2.1 Display via the four "ErrorNo/Select ID" LEDs when the "State" LED lights up green

The "State" LED lights up red: The interface module has detected an error or a warning. The interface module displays the binary-coded error and/or warning number via the "Error No/Select ID" LEDs.

- Error (No. 1...5): Switch the interface module off and back on. If the error occurs again, the module must be replaced.
- Warning (No. 6...15): The warning provides information. The interface module displays the warning for one minute and then resets automatically.

LED ErrorNo/Select ID				Error number	Error description
LED8	LED4	LED2	LED1		
0	0	0	0	0	Reserved
0	0	0	1	1	Hardware error
0	0	1	0	2	EEPROM error
0	0	1	1	3	Internal memory error
0	1	0	0	4	Fieldbus hardware error or incorrect fieldbus ID
0	1	0	1	5	Script error
0	1	1	0	6	Reserved
0	1	1	1	7	WCS read head communication, RS send buffer overflow
1	0	0	0	8	WCS read head communication, RS receive buffer overflow
1	0	0	1	9	WCS read head communication, RS timeout
1	0	1	0	10	General fieldbus error
1	0	1	1	11	Parity error or frame check error
1	1	0	0	12	Reserved
1	1	0	1	13	Fieldbus configuration error
1	1	1	0	14	Fieldbus data buffer overflow
1	1	1	1	15	Reserved

Table 2.2 Significance of the error codes (display via the four "Error No/Select ID" LEDs when the "State" LED lights up red and thus indicates an error or a warning)

Rotary Coding Switches S4 and S5

Rotary coding switches S4 and S5 are used to determine the number of read heads and the protocol used (WCS or WCS Extended); see chapter 4.2.

EtherCAT: LED Status Indicator

Bus State:

ERR State (red LED)	Error	Description
Off	No error	The EtherCAT communication of the device is ready for operation.
Flashing	Invalid configuration	General configuration error (example: wrong object settings)
1 x flashing	Unprompted status change	The application changed the EtherCAT state independently: The parameter "Change" in the AL-status register is set to 0x01: Change/Error
2 x flashing	Application Watchdog Timeout	The application has timed out (example: 10 ms IR error)

RUN State (green LED)	Status	Description
Off	INIT	The device is in the INIT status.
Flashing	PRE-OPERATIONAL	The device is in PRE-OPERATIONAL status.
1 x flashing	SAFE OPERATIONAL	The device is in SAFE-OPERATIONAL status.
On	OPERATIONAL	The device is in OPERATIONAL status.

The states of the LEDs are defined as follows:

LED status	Definition
On	The LED is permanently on.
Off	The LED is permanently off.
Flashing	The LED changes the state from ON to OFF at a frequency of 2.5 Hz: ON for 200 ms, followed by OFF for 200 ms.
1 x flashing	The LED lights up briefly (200 ms), followed by a long OFF phase (1000 ms).
2 x flashing	The LED shows a series of short flashes twice (200 ms), separated by an OFF phase (200 ms). The series is completed with a long OFF phase (1000 ms).

Bus Power:

The "Bus Power" LED is green: The LED is connected directly to the electrically isolated supply voltage of the EtherCAT side.

Link/Activity In:

The "Link/Activity" LED at the IN port is directly activated by the EtherCAT processing unit and lights up **green** when the gateway at the RJ45(In) is located on an operational network (link pulses are received) and flickers in case of network data traffic (activity).

Link/Activity Out:

The "Link/Activity" LED at the OUT port is directly activated by the EtherCAT processing unit and lights up **green** when the gateway at the RJ45(Out) is located on an operational network (link pulses are received) and flickers in case of network data traffic (activity).

3 Installation

3.1 Mounting



Mounting the Modules

The module is fastened to a DIN mounting rail with a width of 35 mm using a snap-on fixing method.

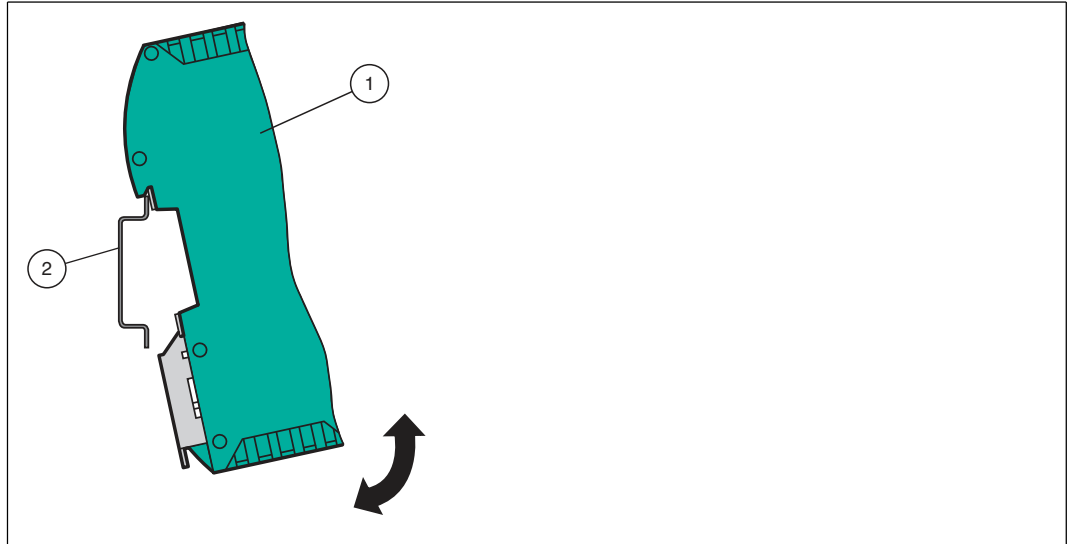

Figure 3.1 Mounting

1. Hook the module (1) onto the DIN mounting rail (2) from above and press it down until it snaps into place.

↳ The module is mounted.



Note

Heat Dissipation

You may place other modules to the left and right of the module. Above and below the modules, there must be at least 5 cm of free space for heat dissipation.

2. You must connect the DIN mounting rail to the switch cabinet's equipotential busbar. The connection wire must have a cross section of at least 10 mm².



Note

Vertical Installation

You can also install the DIN mounting rail vertically, so that the modules can be rotated by 90° for mounting.

3.2 Electrical Connection



Danger!

Device damage due to incorrect installation

Incorrect installation of cables and connection lines can endanger the function and the electrical safety of the device.

- Observe the permissible core cross section of the conductor.
- If you are using stranded conductors, crimp the stranded conductors with wire end ferrules.
- Make sure that conductors are insulated all the way up to the terminal.
- Observe the tightening torque for the screws on the terminal. The tightening torque is 0.5 Nm.
- Using an unsuitable tool may damage the screw heads. Use a slot-head screwdriver sized 3.5 x 0.5.
- Connecting an alternating current can damage the device or cause the device to malfunction. Connect the device to direct current (DC).

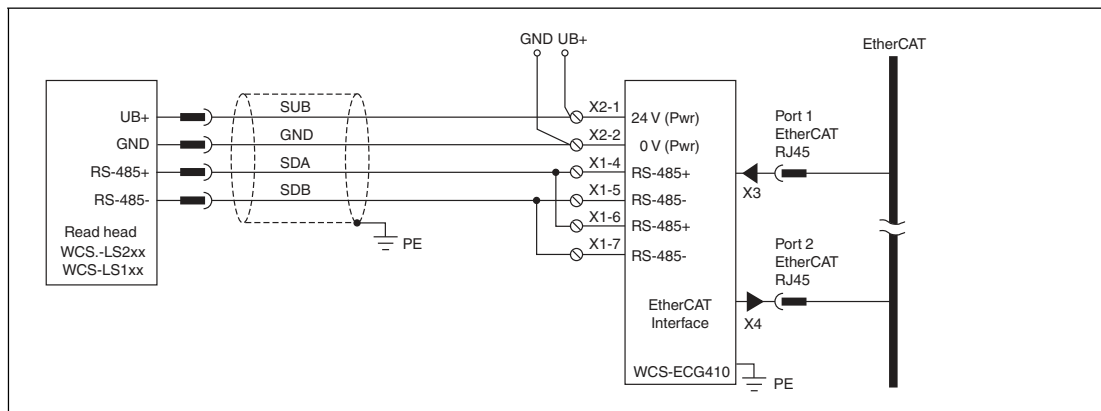

Figure 3.2 Electrical connection

Plug X1 is located on the top side of the interface module, and plug X2 is located on the underside.

Connection Technology

You must/may use the following connection technologies when wiring the assembly:

- Standard screw/plug connection (supply + RS)
- 8-pin RJ45 connection (EtherCAT connection)

When using standard screw terminals, one cable per connection point can be clamped. To tighten the screws, use a screwdriver with a blade width of 3.5 mm.

Permissible cable cross section:

- Flexible cable with wire end ferrule: 1 x 0.25 ... 1.5 mm²
- Solid cable: 1 x 0.25 ... 1.5 mm²

The plug-in terminal strip combines a standard screw connection and a connector. The connector is coded and therefore cannot be plugged in incorrectly.



Connecting the Power Supply

Connect the operating voltage (10 VDC...30 VDC) to terminals 1 and 2 of the 4-pin plug X2 on the interface module. In addition, note the label on the module.

↳ The "Power" LED lights up green.

Terminal X2

Terminal	Description
1	UB+ (Pwr) Operating voltage for interface module/ operating voltage for WCS read head
2	0 V (Pwr) Ground for interface module/ground for WCS read head
3	not used is not used
4	not used is not used

Equipotential Bonding Connection

The connection to equipotential bonding occurs automatically when attaching to the DIN mounting rail.



EtherCAT Communication Interface

This interface can be found on the interface module in the form of two 8-pin RJ45 sockets on the bottom of the housing.

Insert the EtherCAT connector into one of the RJ45 socket(s) labeled "In" (cable from master) or "Out" (further cable to the next EtherCAT slave).



Note

Ensure that the cable length to the neighboring EtherCAT devices is at least 0.6 m.



Preparing for Operation on RS-485 Interface

For operation on an RS-485 interface, the terminal on plug X1 must be connected:

Connect the read head to the terminal. Use the enclosed jumper to connect the terminals to each other

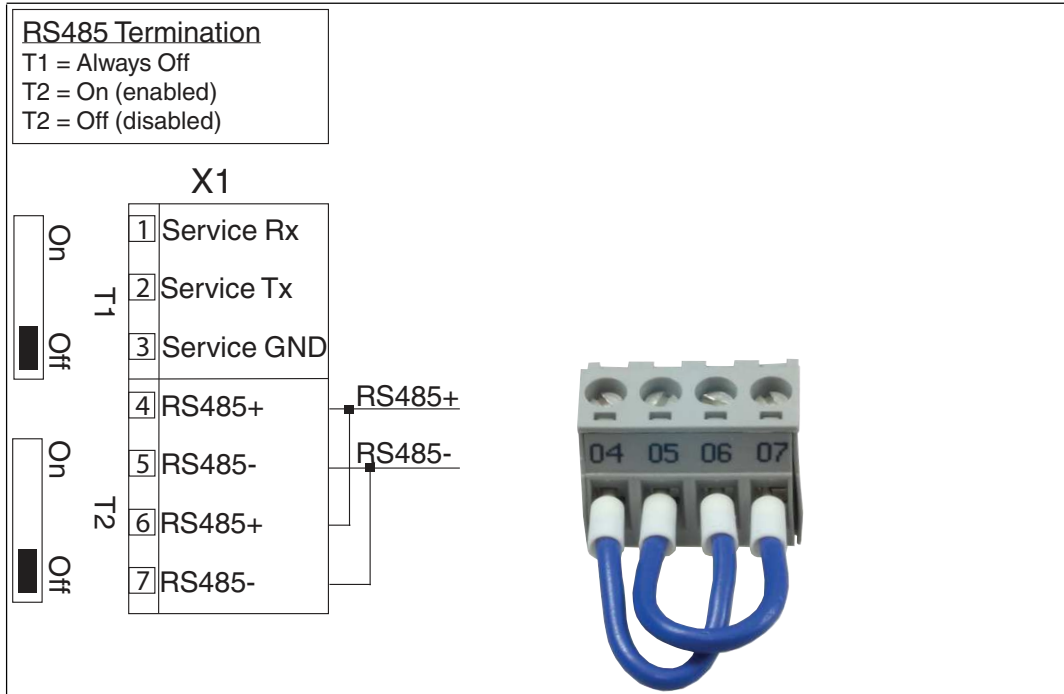

Figure 3.3 Terminal X1

3.3 Dismounting



Dismounting the modules

Use a suitable slot-head screwdriver for dismounting the module.

1. Disconnect all the supply and signal lines.

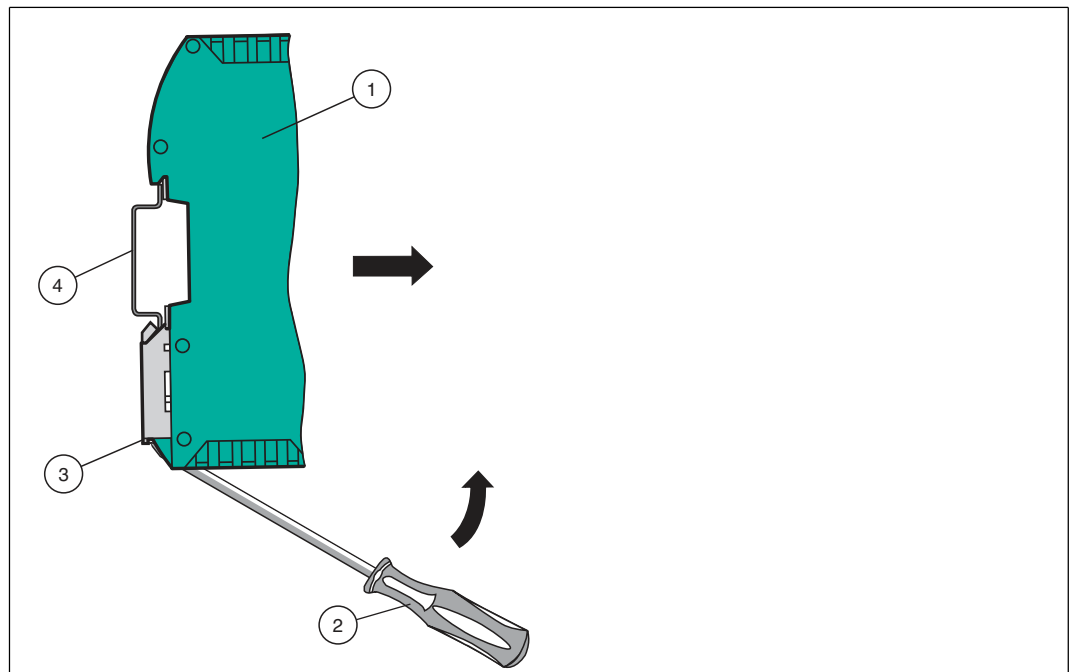

Figure 3.4 Dismounting

2. Insert the screwdriver (2) into the groove of the mounting bracket (3).
3. Press the screwdriver (2) in the specified direction until the lock on the DIN mounting rail (4) opens, see figure.
4. Then press the module (1) upwards and lift it out of the DIN mounting rail.

4 Commissioning

4.1 Introduction



Warning!

Danger to life due to defective work

Errors during installation and commissioning can cause life-threatening injuries and significant property damage.

- Installation and commissioning must be carried out only by trained personnel in accordance with safety regulations.

Components

To commission the module, you will require the following components:

- WCS-ECG410 interface module
- ESI file (the ESI file can be obtained free of charge from our website www.pepperl-fuchs.com.)
- Cordset from the interface module to the read head
- Connector for the EtherCAT connection to the interface module
- Ethernet cable
- 10 VDC...30 VDC voltage supply



Downloading the ESI File

You will need an ESI file to operate the module described in this manual. The ESI file must be imported into the corresponding configuration tool before commissioning the module. The ESI file can be downloaded from our website: <http://www.pepperl-fuchs.com>. Simply enter the product name or item number in the product/keyword field and click "Search."

1. To access the product detail page for the device, go to <http://www.pepperl-fuchs.com> and enter information about the device (e.g., the product description or the item number) into the search function.
2. Select your product from the list of search results. Click the information you require in the product information list, e.g., **Software**.



↳ A list of all available downloads is displayed.



Connecting the Interface Module

To ensure that the assembly functions correctly, you must carry out the following steps during commissioning:

1. Assign an EtherCAT address.



Note

On delivery, the module does not yet have an IP address. In normal operation, the IP address is usually assigned to the module by the EtherCAT IO controller (PLC).

2. Assign an EtherCAT device name.



Note

On delivery, the module does not yet have a device name. The device name is assigned to the module via the project planning software.

3. Connect the module to the EtherCAT network on the interface labeled "In" (cable from master) or "Out" (further cable to the next slave).
4. Connect the process device (read head) to the interface module. For information on commissioning the read head, please refer to the instruction manual for the read head.
5. Ground the DIN mounting rail onto which the assembly is clipped.
6. Connect the direct current to the terminals provided.
7. Use any programming tool for project planning. The ESI file can be downloaded from our website: www.pepperl-fuchs.com. Simply enter the product name or item number in the product/keyword field and click "Search."



Note

A more detailed description of the individual steps is provided on the following pages.

4.2 Connecting the WCS Read Head

If you connect several WCS read heads to one interface module, the WCS read heads must have different addresses. This will allow the programmable logic controller to allocate the data to the correct WCS read heads. If you connect only one WCS read head to an interface module, this WCS read head always receives the address 0. You can connect up to WCS read heads to an interface module via an RS-485 cable. Each WCS read head is supplied with the default address of 0. Details of how to change the address of the WCS read head can be found in the configuration instructions for the WCS read head.

WCS read head connection pin		Terminal on interface module
WCS2B	WCS3B	
2	1	X2-1
4	2	X1-4
1	4	X1-5
3	3	X2-2

Table 4.1 Connection of WCS read heads

Setting the Number of Connected WCS Read Heads

Set the number of connected WCS read heads with the rotary switch S4 in accordance with the table "Rotary switch S4."

Rotary switch S4

Switch position S4	Number of WCS read heads	Read head address
1	1 WCS read head	0
2	2 WCS read heads	0, 1
3	3 WCS read heads	0, 1, 2
4	4 WCS read heads	0, 1, 2, 3
5	1 WCS read head with velocity output	0
6	2 WCS read heads with velocity output	0, 1
7	3 WCS read heads with velocity output	0, 1, 2
8	4 WCS read heads with velocity output	0, 1, 2, 3

Table 4.2 Position of rotary switch S4 for setting the number of WCS read heads



Example

You have connected three read heads to the interface module and want to use the velocity output. Set the rotary switch S4 to switch position 7 and set the addresses 0,1,2 on the three read heads.

Rotary Coding Switch S5

The Extended protocol (traverse distance 629.146 meters) is set on the interface module using rotary switch S5. The WCS read heads are addressed via a modified prompt bit. A total of one byte more is transferred in the response telegram of the WCS Extended protocol. For more information on the data format, refer to the WCS electrical manual (DOCT-5959).

Rotary switch S5 = switch position 0 for WCS standard (read head WCSxB-LS221*)

Rotary switch S5 = switch position 1 for WCS Extended 629.146 meters (read head WCS3B-LS*E*)

Other states/switch positions are not permitted.

WCS Extended enables up to four RS-485 read heads to be connected to an interface module.



Connecting the WCS Read Head

1. Connect the voltage supply for the WCS read head on terminals 1 and 2 of the 4-pin plug X2 on the interface module.
2. Connect the RS-485 data cable to the WCS read head on terminals 4 and 5 of plug X1.



Activating the RS-485 Bus Termination

If the interface module is operated as the first or last physical device in an RS-485 bus or if you operate one read head on the interface module, a bus termination must be performed on this interface module.

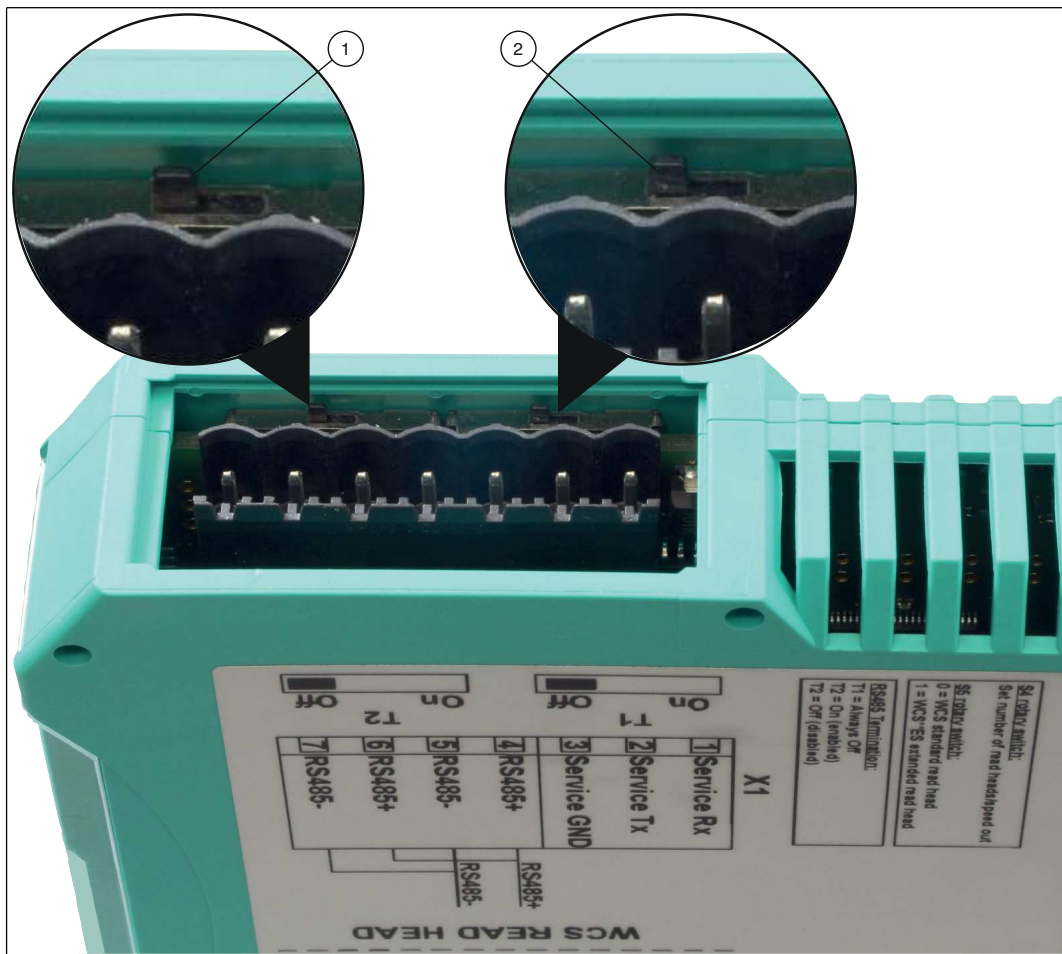

Figure 4.1 RS-485 Bus Termination

Set the T2 slide switch (1) to "On" to activate the bus termination (150 Ω).



Note

The T1 slide switch (2) has no function and remains in the "Off" switch position.

4.3 Connection to the Network

The connection to the EtherCAT IO is made via the two "RJ45 EtherCAT IN and OUT" sockets on the underside of the interface module. The front socket is labeled "X3 IN," and the rear socket is labeled "X4 OUT." Connect the device to the EtherCAT network to the interface labeled "In" (cable from master) or "Out" (further cable to the next slave).



Note

The cable to the surrounding Ethernet devices must be at least 0.6 m long.

Pinout X3 IN & X4 OUT

Terminal		Designation
1	TD+	Transmission line +
2	TD-	Transmission line -
3	RD+	Receive line +
4	n.c.	Not connected
5	n.c.	Not connected
6	RD-	Receive line -
7	n.c.	Not connected
8	n.c.	Not connected

Table 4.3 Terminals of the 8-pin "RJ45 EtherCAT IO" sockets



Connecting the device to the controller

Plug the EtherCAT connector into the RJ45 socket. Use a data cable of at least Category 5.

4.4 Integrate Interface Module into the Network



Caution!

Malfunction due to incorrectly configured devices

Incorrectly configured devices can cause malfunction of the plant.

- Only put devices into operation after they have been configured correctly.

You will need an ESI file to operate the module described in this manual. The ESI file must be imported into the corresponding configuration tool before commissioning the module. The ESI file can be downloaded from our website: www.pepperl-fuchs.com. Simply enter the product name or item number in the Product/Keyword field and click the "Search" icon.

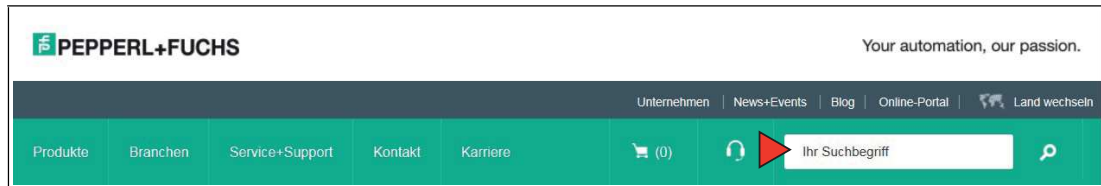

Select your product from the list of search results. Click on the information you require in the product information list, e.g., **Software**.

A list of all available downloads is displayed.

EtherCAT® address assignment

On delivery, the interface module does not yet have an IP address. In normal operation (data exchange mode), the IP address is usually assigned to the module by the EtherCAT® IO controller (PLC). For this purpose, the module has a device name that is used to address it.

EtherCAT® device name

On delivery, the module does not yet have a device name. The device name is assigned to the module via the project planning software. The following rules from the EtherCAT® specification apply to the device name:

- It consists of one or more name parts separated by a dot
- The total length is 1 to 240 characters.
- The length of a name part is between 1 and 63 characters.
- A name part consists exclusively of lowercase letters, numbers, and the hyphen.
- Neither the first nor the last character of a name part is a hyphen.
- The first part of the name does not begin with "port-xyz" or "port-xyz-abcde," where a, b, c, d, e, x, y, and z are digits.
- It does not have the form "k.l.m.n," where k, l, m, and n are numbers between 0 and 999.

Note

Various configuration tools are available to allow you to configure the interface module. In this manual, we describe the configuration example for EtherCAT® Master "TwinCAT" by Beckhoff. If you are using a programmable logic controller (PLC) from a different manufacturer, the process will be similar to the one described here.



Adding the device to the network

1. Download and install the software "TwinCAT 3.1 - eXtended Automation Engineering" (XAE). The software is available on the website of the manufacturer Beckhoff at <http://www.beckhoff.com/english.asp?download/tc3-download-xae.htm>.
2. After the installation, copy the ESI file into the following folder:
C:\TwinCAT\3.1\Config\lo\EtherCAT
3. Open TwinCAT V3 and check to see if your Ethernet card works with the software. If your device is displayed in the sub-folder "Installed and ready to use devices", you can proceed.

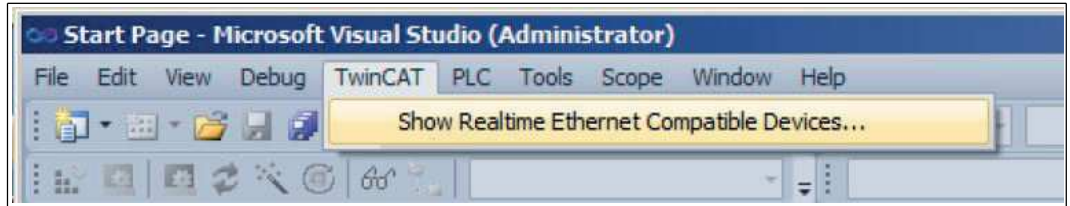

4. Open a new TwinCAT project.

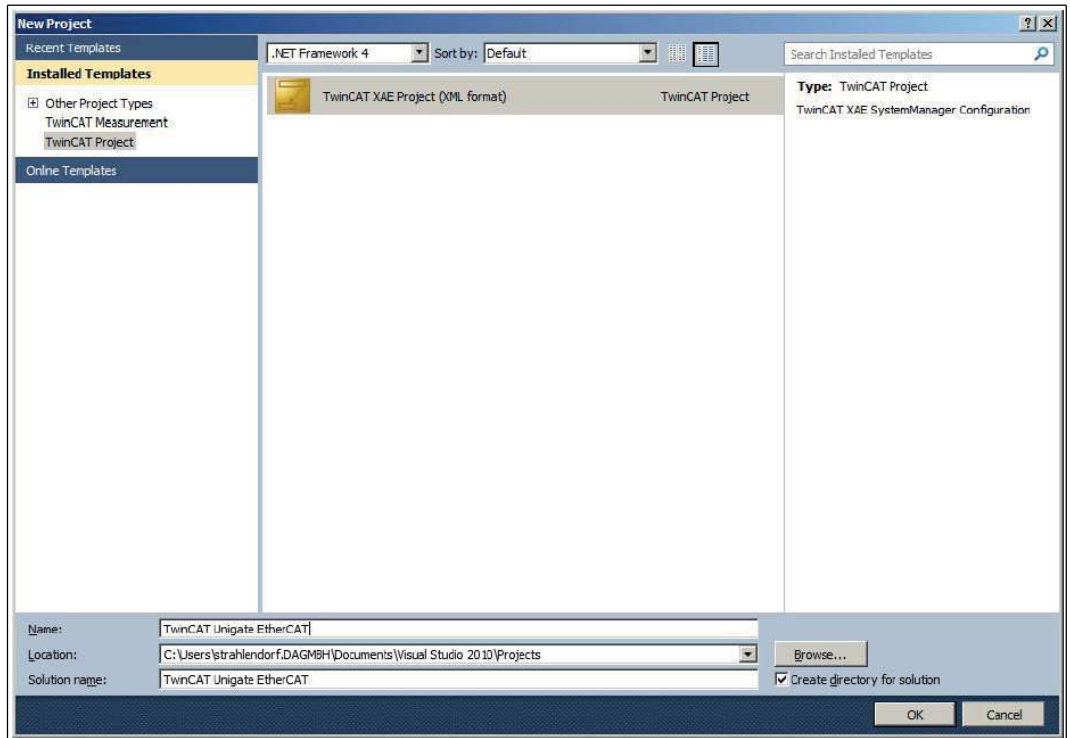

5. Click through the device tree until you see a symbol with the label Devices. Right-click the symbol and select **Scan**.

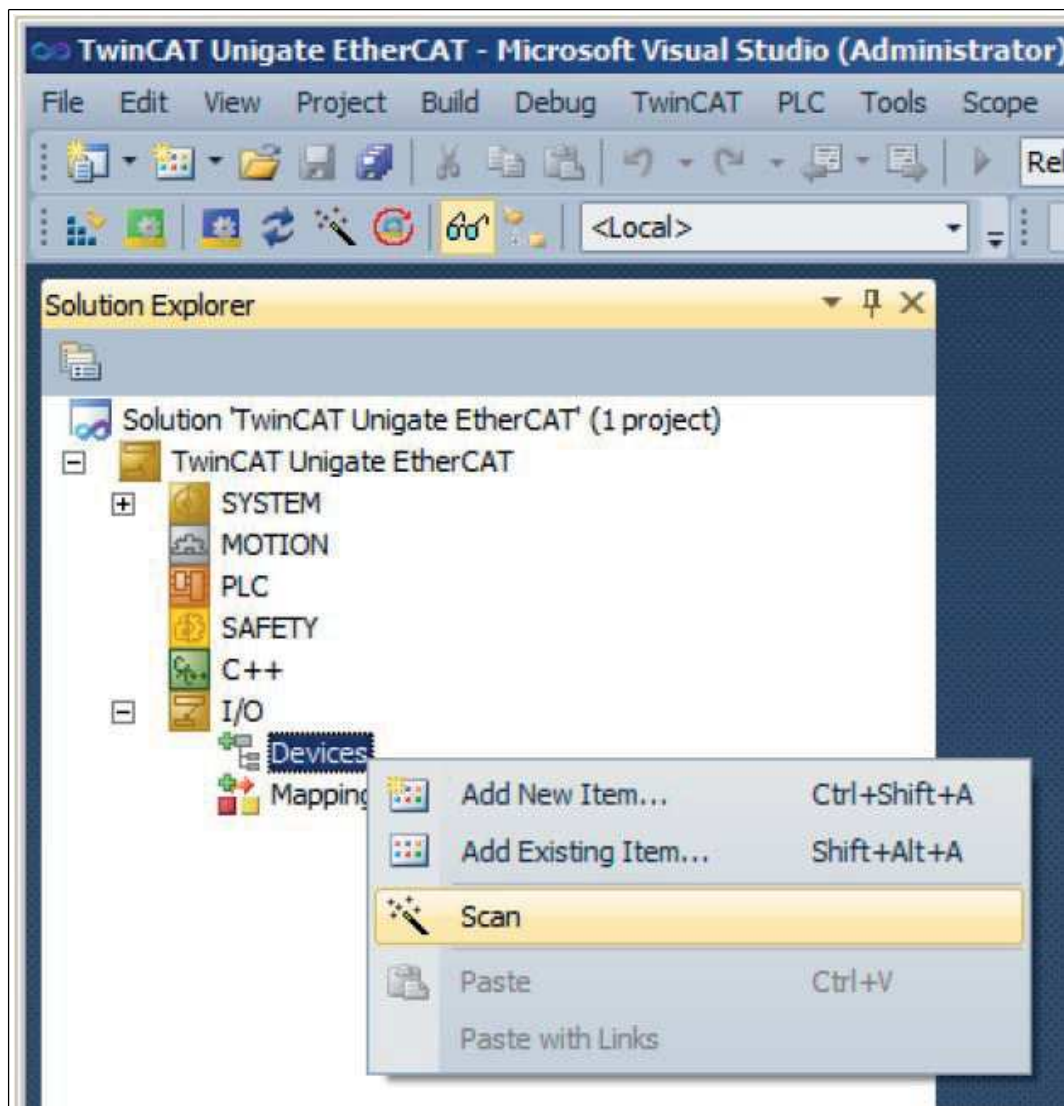

↳ A window **1 new I/O devices found** opens if a device was detected. The device can now be added to the device tree.

6. Double-click on the device symbol.
↳ The **Properties** window opens.
7. Enter the required network configuration.



Searching for a device on the network

To search for a new device, click through the device tree until you see a symbol with the label **Devices**. Right-click the symbol and select **Scan**.

↳ The PLC interrogates the network to see which nodes are present (Broadcast query). A list of the connected devices is displayed in the window.



Changing the device name



Note

The PLC must not communicate with the device via EtherCAT while you are changing the device name. If you try to change the device name while the plant is in operation, an error message will be output.

1. Stop communication if it is active.
2. Select **Pepperl+Fuchs WCS** from the list of nodes (default device name: UNIGATE-IC) and double-click on the device symbol.

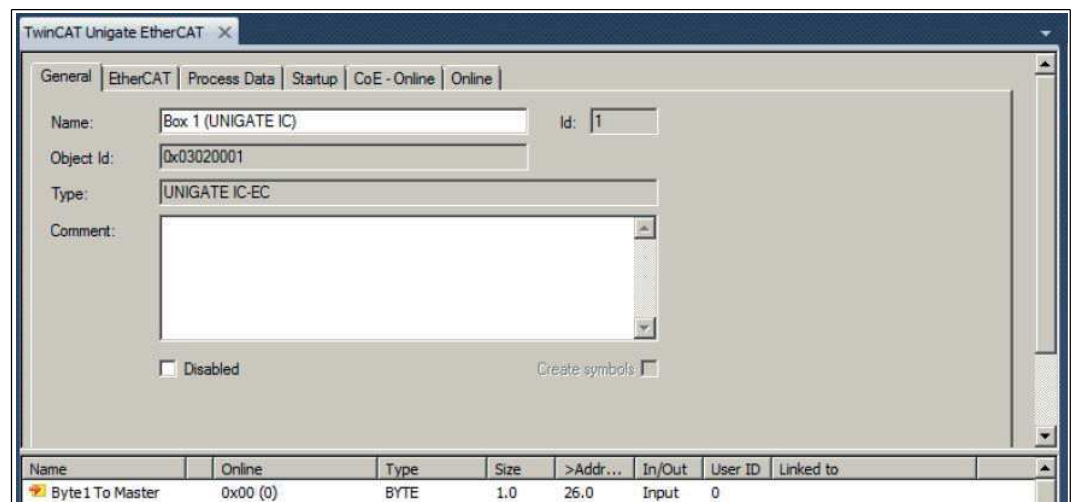

3. In the WCS module **Properties** window, enter the new device name in the **Name** field and save the configuration.
 ↳ The interface module is given the name you entered and can then be uniquely identified by the PLC.

Depending on your application, select one, two, three or four connected readers and the operating mode. In the first 4 operating modes, the readers output their position. In the "Position and Speed" operating mode, the readers output their position and the speed at which they are currently moving.

4.5 Data Format for Modules

In "only Position" operating mode, 4 bytes are reserved for each WCS reader.

Bit	7	6	5	4	3	2	1	0
Byte 0	0	0	0	0	0	P18	P17	P16
Byte 1	P15	P14	P13	P12	P11	P10	P09	P08
Byte 2	P07	P06	P05	P04	P03	P02	P01	P00
Byte 3	0	0	0	DB	ERR	OUT	A1	A0

Table 4.4 Data format for each connected WCS reader in "only Position" operating mode, reader address = 0...3

In "Position and Speed" operating mode, 6 bytes are reserved for each WCS reader.

Bit	7	6	5	4	3	2	1	0
Byte 0	0	0	0	0	0	P18	P17	P16
Byte 1	P15	P14	P13	P12	P11	P10	P09	P08
Byte 2	P07	P06	P05	P04	P03	P02	P01	P00
Byte 3	0	0	0	DB	ERR	OUT	A1	A0
Byte 4	0	0	0	0	0	0	0	0
Byte 5	0	S06	S05	S04	S03	S02	S01	S00

Table 4.5 Data format for each connected WCS reader in "Position and Speed" operating mode, reader address = 0...3

Pxx: position data, P00 = LSB

Sxx: speed (in multiples of 0.1 m/s), S00 = LSB

Example: Byte 5 = 00011011 = 27, corresponds to 2.7 m/s

A1, A0: reader address, 00 = WCS reader address #1

DB: pollution display, 1 = cleaning necessary

OUT: code rail loss, 0 = code rail recognized

ERR: error display, error code (LEDs)

Address bits A1 and A0

A1	A0	Reader address
0	0	Reader address 0
0	1	Reader address 1
1	0	Reader address 2
1	1	Reader address 3

Status bits

DB	ERR	OUT	Description	Optical state of WCS reader
0	0	0	Current position value binary coded in P00...P18	Good
0	0	1	WCS reader outside of the code rail, not a position value	Good
			P0...P18=0: WCS reader partly outside the code rail	
			P0=1, P2...P18=0: WCS reader completely outside of the code rail	
1	0	0	Current position value binary coded in P00...P18	Poor
1	0	1	No position value, WCS reader outside of the code rail	Poor
X	1	X	No position value, error message from WCS reader, error number binary coded in P00...P18	-

5 Communication with WCS Read Heads

5.1 Data Protocols

Data protocol 1

Request byte for read head									
Byte	Bit 8	Bit 7	Bit 6	Bit 5	Bit 4	Bit 3	Bit 2	Bit 1	Bit 0
	1	0	0	0	F0	0	0	A1	A0

Response telegram from the read head									
Byte	Bit 8	Bit 7	Bit 6	Bit 5	Bit 4	Bit 3	Bit 2	Bit 1	Bit 0
Byte 1	0	OUT	ERR	A1	A0	DB	P18	P17	P16
Byte 2	0	P15	P14	P13	P12	P11	P10	P09	P08
Byte 3	0	P07	P06	P05	P04	P03	P02	P01	P00
Byte 4	0	OUT	ERR	A1	A0	DB	P18	P17	P16
Byte 5	0	P15	P14	P13	P12	P11	P10	P09	P08
Byte 6	0	P07	P06	P05	P04	P03	P02	P01	P00

Data protocol 1 with position and velocity output

Request byte for read head									
Byte	Bit 8	Bit 7	Bit 6	Bit 5	Bit 4	Bit 3	Bit 2	Bit 1	Bit 0
	1	1	0	0	0	0	0	A1	A0

Response telegram from the read head									
Byte	Bit 8	Bit 7	Bit 6	Bit 5	Bit 4	Bit 3	Bit 2	Bit 1	Bit 0
Byte 1	0	OUT	ERR	A1	A0	DB	P18	P17	P16
Byte 2	0	P15	P14	P13	P12	P11	P10	P09	P08
Byte 3	0	P07	P06	P05	P04	P03	P02	P01	P00
Byte 4	0	SST	SP6	SP5	SP4	SP3	SP2	SP1	SP0
Byte 5	0	OUT	ERR	A1	A0	DB	P18	P17	P16
Byte 6	0	P15	P14	P13	P12	P11	P10	P09	P08
Byte 7	0	P07	P06	P05	P04	P03	P02	P01	P00
Byte 8	0	SST	SP6	SP5	SP4	SP3	SP2	SP1	SP0

Description of the protocol data

Activation of the read head

F0	A1	A0	Read head address
x	0	0	Read head address 0
x	0	1	Read head address 1
x	1	0	Read head address 2
x	1	1	Read head address 3
0	x	x	Send position value
1	x	x	Send diagnosis result

Data from read head

Function number for read head F0=0 (send position value)					
ERR	DB	OUT	SST	Description	State of the read head lens
0	0	0	x	Current position value in P00 ... P18, binary coded	Good
0	0	1	x	Read head outside the code rail, no position value (see OUT message)	Good
0	1	0	x	Current position value in P00 ... P18, binary coded	Poor
0	1	1	x	No position value, read head outside the code rail (see OUT message)	Poor
1	x	x	x	No position value, error message from read head, error number in P00 ... P04, binary coded	-
x	x	x	1	Current speed unknown, last speed in SP0 ... SP6 *)	-
x	x	x	0	Current speed in SP0 ... SP6 *)	-

*) Speed information

The speed is binary coded in bits SP0 to SP6.

SP0...SP6...	Speed in 0.1 m/s, binary coded
0:	Speed less than 0.1 m/s
126:	Speed more than 12.5 m/s
127:	Speed unknown

Example:

SP0...SP6...	1:	Speed 0.1 m/s
	37:	Speed 3.7 m/s
	112:	Speed 11.2 m/s

Diagnostic function F0=1

The read head can be requested to perform a diagnosis of the photoelectrics via the request byte to the read head. For this purpose, the read head must be located outside of the code rail. On the WCS2B and WCS3B read heads, the degree of dirt accumulation on the photoelectrics is monitored automatically during operation and the diagnostic bit (DB) set if dirt accumulation is too high. Thus the request for diagnosis to the read head via F0 in the request byte is no longer necessary. However, for reasons of downward compatibility, this function is also supported by the new read heads.

Diagnostic bit (DB)

Diagnostic bit DB displays the result of the integrated diagnostics of the read head.

Function number for read head F0 = 1 (send diagnosis result)				
ERR	DB	OUT	Description	State of the read head lens
0	1	0	Diagnosis invalid, read head not outside of the code rail	-
0	1	1	Diagnosis result in P16 ... P18	-
			P16 ... P18 = 0	Good
			P16 ... P18 > 0	Poor
1	x	x	Error message from read head, error message in P00 ... P04, binary coded	-

Contamination detection

Read heads WCS2B and WCS3B continually monitor the condition of the lenses. If a drop in light output is detected on the infrared transmitter, e.g., as a result of contamination of the clear protective lenses, the read head automatically increases the light intensity. If the level of contamination is too high, a warning message is sent to the higher-level control panel (diagnostic bit DB=1). The automatic light adjustment in the read head allows you sufficient time to clean the read head as part of the next servicing procedure. The WCS3B read head emits a visual signal for the "contamination detected" state: the yellow and red LEDs on the front of the read head flash alternately. To clean the lenses, the read head must be removed from the code rail (removed from the mounting base). After cleaning the transparent protective lenses, the contamination message is automatically deleted from the read head. If the message is not reset despite careful cleaning or replacement of the plastic protective lenses, there may be an error. In this case, the read head must be sent for inspection.

OUT message

Function number for read head F0 = 0 (send position value)					
ERR	DB	OUT	SST	Description	State
0	x	1	x	P00...P18 = 0 -> read head is partially outside the code rail	OUT
				P00 = 1, P02...P18 = 0 -> read head is completely outside the code rail	OUT A

OUT means that the position value cannot be determined because the position of the code rail in the read head gap is incorrect.

OUT A (A=All) means that there is no code rail in the read head gap; all light barriers of the read head report a signal.

The "OUT" message may be desirable and correct, e.g., if the code rail is interrupted and the read head sends this information between the individual rail pieces to the control panel. If the "OUT" message must not occur, the following test steps must be performed:

Result of the check	Remedy
The upper edge of the code rail is outside the tolerance range of the read head	<ul style="list-style-type: none"> Align the code rail precisely Align the read head Use the guide system for the read head
The plastic protective lenses on the optical unit are dirty or scratched	<ul style="list-style-type: none"> Clean optical unit Ensure the read head is cleaned Change the protective lenses
Incidence of extraneous light	<ul style="list-style-type: none"> Protect the read head against any incidence of extraneous light

If these measures do not solve the problem, the read head must be sent for inspection.

5.2 Option-E—Extended, Type WCS3B-LS2*E*, RS-485

The read head **WCS3-Extended: WCS3B-LS*E*** with RS-485 interface is used for routes of more than 314.573 m. In this case, the additional "E" in the type code identifies the extended version for the extending code rail. Two standard code rail segments with a length of 0 ... 314.573 m are connected to each other with the WCS3-CS70-E code rail extender to achieve a maximum code rail length of up to 629.146 m. The first code rail segment must always be complete, or end with the position at 314.573 m. The second code rail segment can have a shorter length of 314.573 m to X m, but must be used in descending position, starting at 314.573 m.

Extended data protocol with position output

Request byte for read head									
Byte	Bit 8	Bit 7	Bit 6	Bit 5	Bit 4	Bit 3	Bit 2	Bit 1	Bit 0
	1	0	1	1	0	0	1	A1	A0

Response telegram from the read head									
Byte	Bit 8	Bit 7	Bit 6	Bit 5	Bit 4	Bit 3	Bit 2	Bit 1	Bit 0
Byte 1	0	A1	A0	OVL	/VAL	DB	OUT ALL	OUT	ERR
Byte 2	0	0	0	0	0	XP19	XP18	XP17	XP16
Byte 3	0	XP15	XP14	XP13	XP12	XP11	XP10	XP09	XP08
Byte 4	0	XP07	XP06	XP05	XP04	XP03	XP02	XP01	XP00
Byte 5	0	xor B1.7..B4 .7	xor B1.6..B4 .6	xor B1.5..B4 .5	xor B1.4..B4 .4	xor B1.3..B4 .3	xor B1.2..B4 .2	xor B1.1..B4 .1	xor B1.0..B4 .0

Data protocol with position and velocity output

Request byte for read head									
Byte	Bit 8	Bit 7	Bit 6	Bit 5	Bit 4	Bit 3	Bit 2	Bit 1	Bit 0
	1	1	1	1	0	0	1	A1	A0

Response telegram from the read head									
Byte	Bit 8	Bit 7	Bit 6	Bit 5	Bit 4	Bit 3	Bit 2	Bit 1	Bit 0
Byte 1	0	A1	A0	OVL	/VAL	DB	OUT ALL	OUT	ERR
Byte 2	0	0	0	0	0	XP19	XP18	XP17	XP16
Byte 3	0	XP15	XP14	XP13	XP12	XP11	XP10	XP09	XP08
Byte 4	0	XP07	XP06	XP05	XP04	XP03	XP02	XP01	XP00
Byte 5	0	SST	SP6	SP5	SP4	SP3	SP2	SP1	SP0
Byte 6	0	B1.7..B5 .7	B1.6..B5 .6	B1.5..B5.5	B1.4..B5 .4	B1.3..B5 .3	B1.2..B5 .2	B1.1..B5 .1	B1.0..B5 .0

Description of the protocol data

Byte 1

A1, A0		Address bits of the read head. Addresses 0 ... 3, binary coding
OVL	0	The read head is located in the readable area of the code rail
	1	The read head is located on WCS3 code rail extender (overlapping area of the code rail segments)
VAL	0:	Position valid
	1	Position invalid; code rail area is not unique after the supply voltage has been connected
DB	0	By default, the diagnostic bit is not set
	1	Diagnostic bit, read head dirty
OUT ALL	0	Read head in code rail
	1	Read head completely outside of the code rail
OUT	0	Read head in code rail
	1	Read head partially outside the code rail. No valid position available
ERR	0	No error
	1	Error message (possible errors in XP00 ... XP01 binary coding)

Byte 2 ... 4

XP00 ... XP19 Current position value, binary coding

Byte 5 ¹

SP0 ... SP6 Current speed in 0.1 m/s, binary coding

Example:

- 1: Speed = 0.1 m/s
- 37: Speed = 3.7 m/s
- 112: Speed = 11.2 m/s

SST	0	Speed valid
	1	Current speed unknown. Last valid speed in SP0 ... SP6 saved

Byte 5/6

Exclusive or link, byte 1 ... Byte 4/5

1. For data protocol with velocity output

Behavior of the read head in the area of the WCS3 code rail extender (WCS3-CS70-E)

The read head retains the last measured end position of the first code rail segment (position = 393203) when traversing the WCS3 code rail extender. The OVL bit is set at the same time. As soon as the first valid position of the second code rail segment is read, the read head switches to the first valid position of the second code rail segment (position = 393318). The first valid position of the second code rail segment is dimensioned with an offset of approx. + 92 mm (see area highlighted in yellow in the figure below).

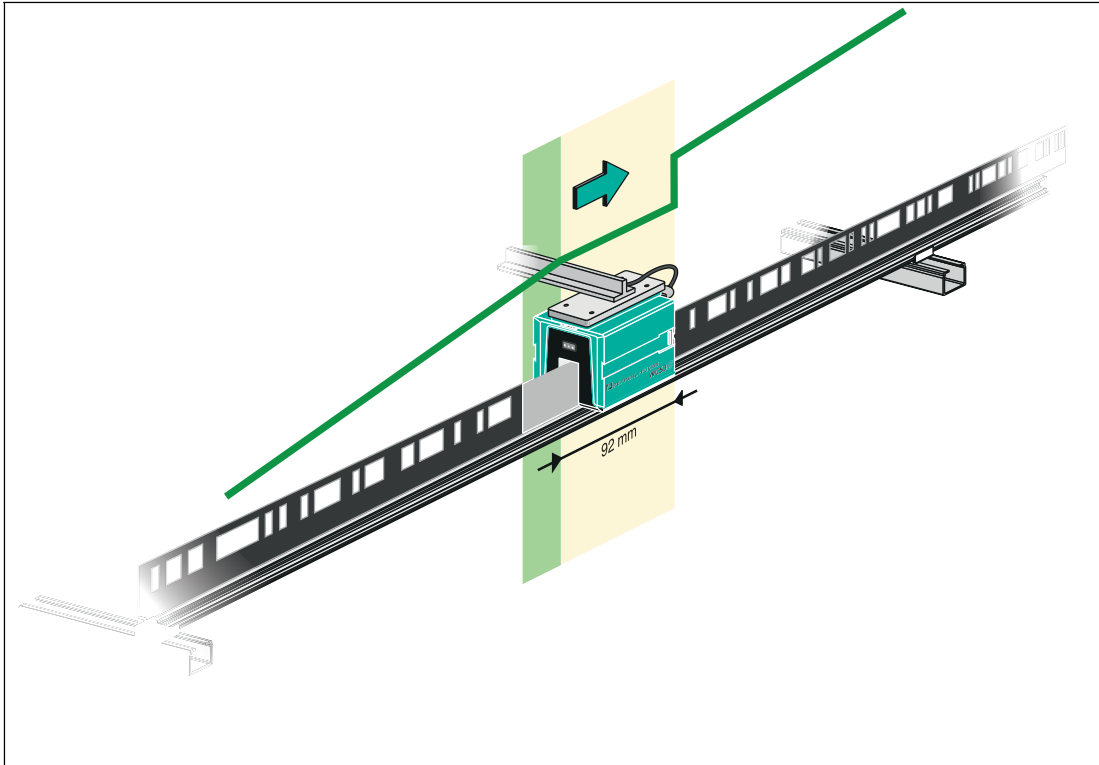

Caution!

Impermissible state

If you mount the WCS3 code rail extender in the wrong position, e.g., at an intermediate position of the code rail, the OUT bit is set when this code rail segment is crossed.



Note

Cycle time

Note that the cycle time for the extended variant differs from the standard variant by $t = 10$ ms.

Start-up behavior of the read head

After the supply voltage has been connected, the X position is set to the last valid X position and the VAL bit is set to 1.

The speed value is 127 and the SST bit is set to 1.

After the read head moves by approx. 5 mm, the VAL bit is set to 0 and the X position is assigned a new calculated X position. The last valid X position is stored in a non-volatile memory if it is detected that the voltage is switched off ($+U_b < 9.9$ VDC).

6 Appendix

6.1 Cable Routing in the RS-485 Bus

The data cables must always form an in-line connection between the first and the last node. This in-line connection must end with a terminator.

The RS-485 terminators are integrated in the WCS readers and can be switched on and off with the interface module.

If only **one WCS reader** is connected, one device is connected at the beginning and one device is connected at the end of the data line.

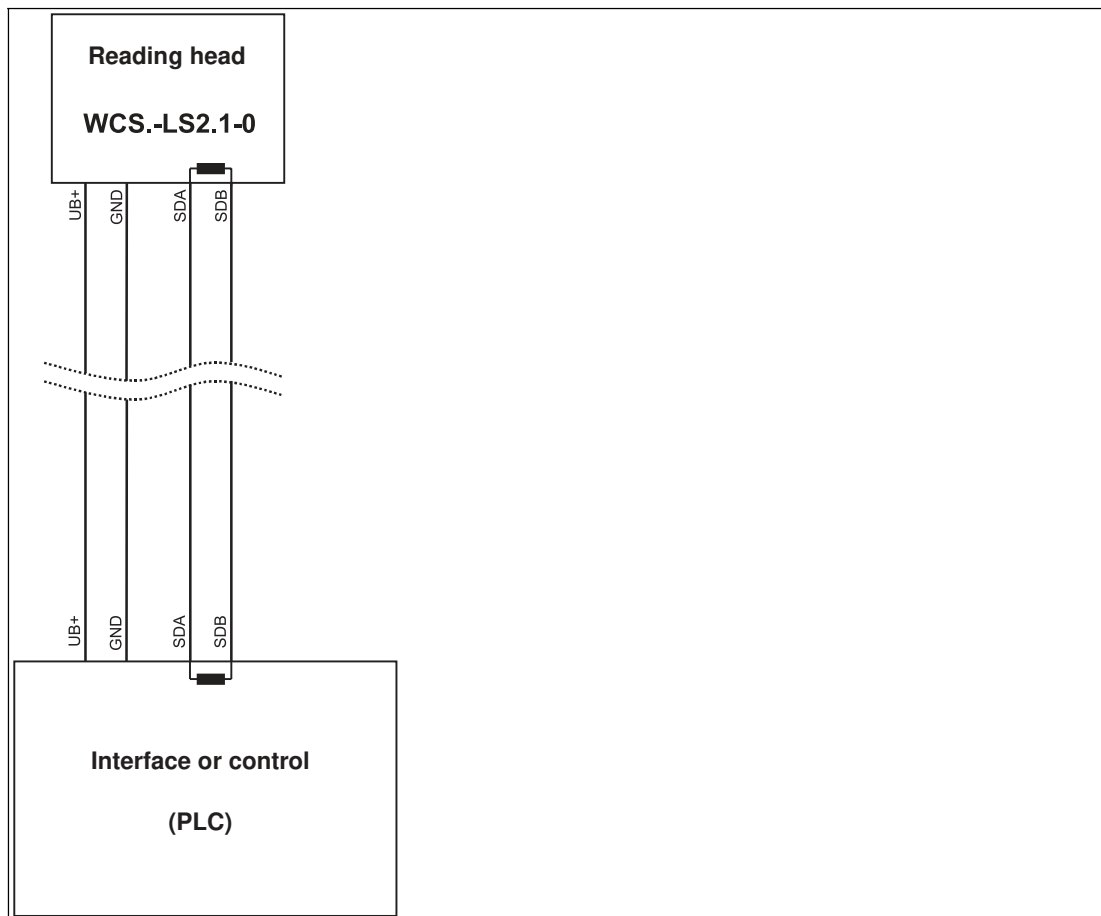

Figure 6.1 Connection of **one** reading head

If **two WCS readers** are connected to one interface module, there are two wiring versions:

- **Version A:**

One WCS reader is located at the beginning and one WCS reader at the end of the data line. For both WCS readers, the RS-485 terminator is activated. The interface module is located between these two readers and does not have an RS-485 terminator. Each WCS reader is connected to the interface module by a separate data cable.

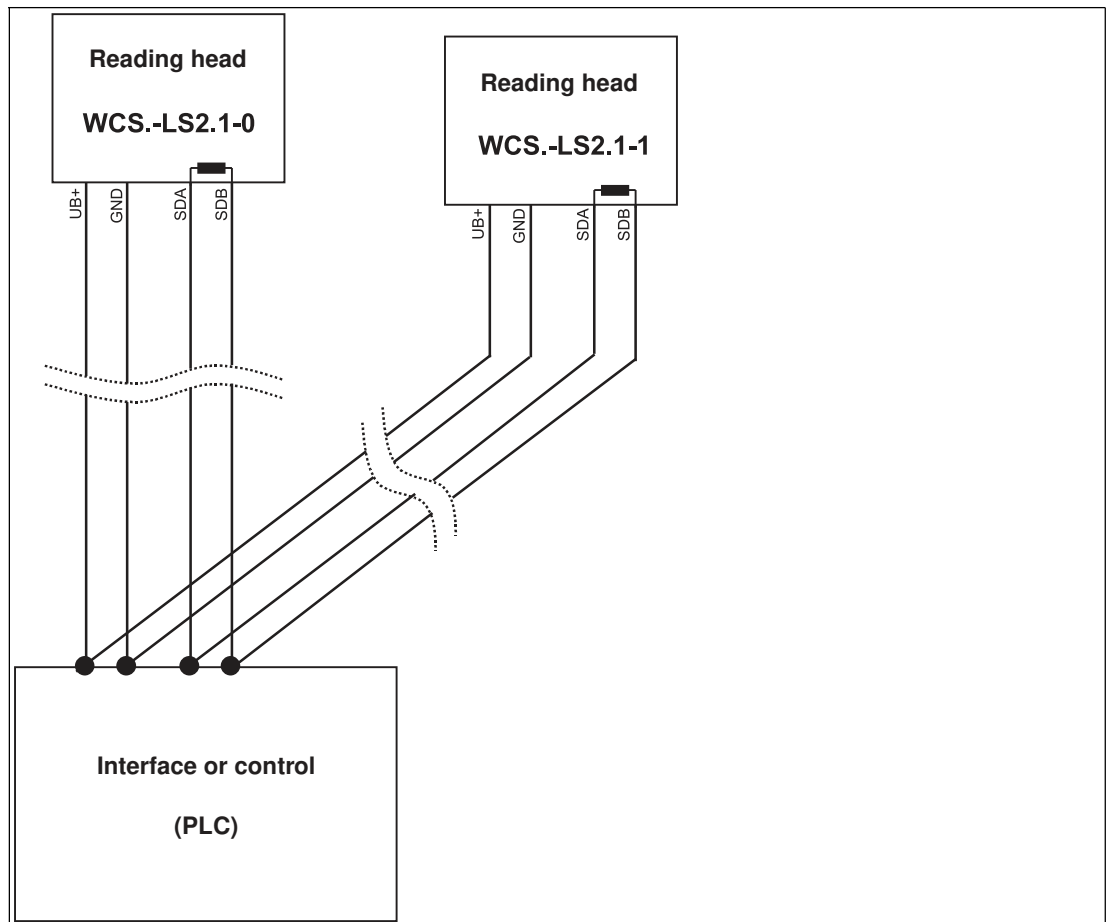

Figure 6.2 Connection of **two** reading heads, Version A

- **Version B:**

The interface module is located at the beginning of the data line; one WCS reader is located at the end of the data line. Both need the RS-485 terminator. The second WCS reader is connected to the line connection between the interface module and the first WCS reader through a short spur (length <1 m). Use a bus terminal to connect the spur.

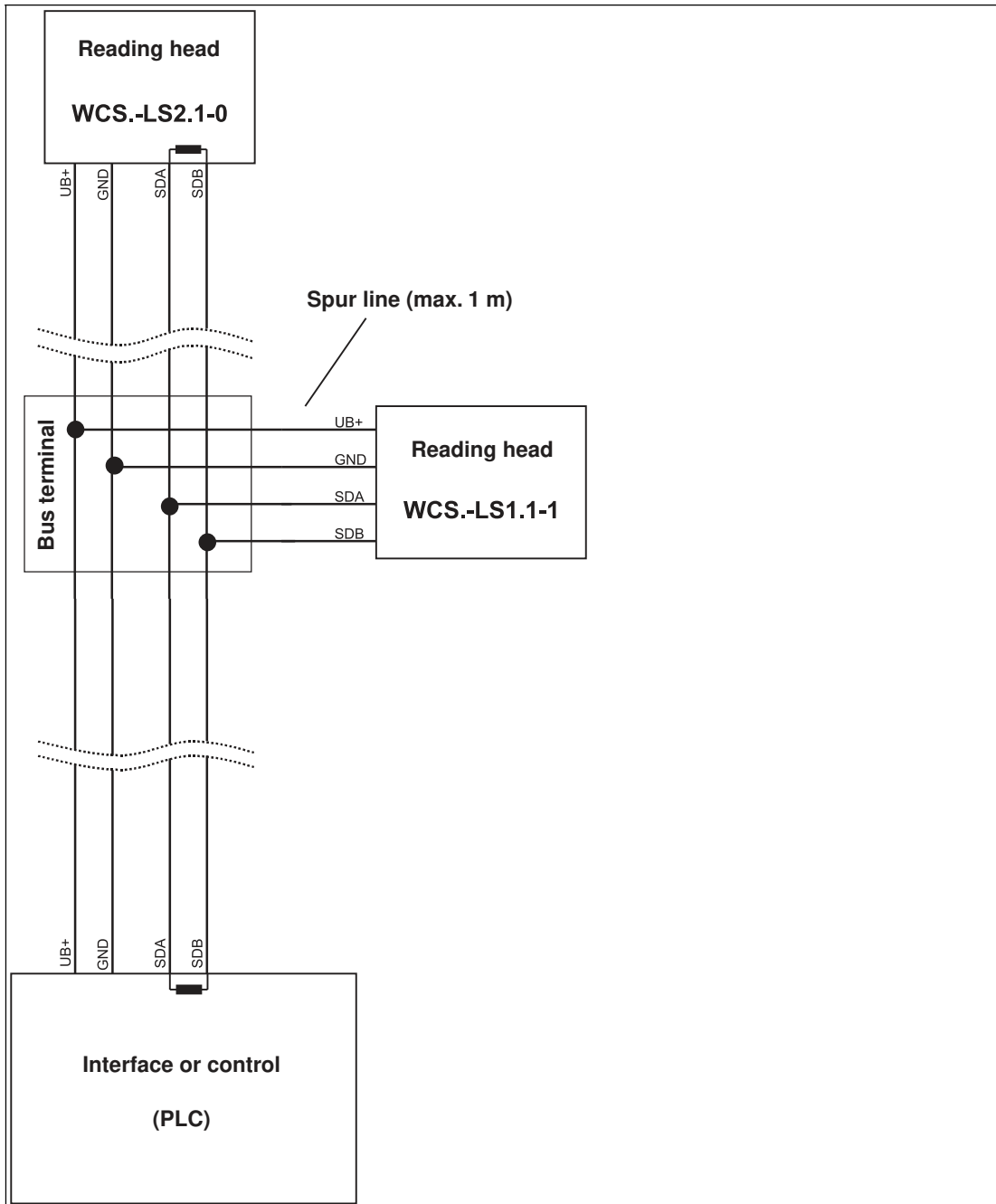

Figure 6.3 Connection of **two** reading heads, Version B

The wiring version used depends on which is best suited for the application. If **three** or **four WCS readers** are used on the same interface module, connect these using spurs as shown in variant B.

6.2 Data Cable

A shielded data cable with twisted-pair cores is used for the electrical connection. Pepperl+Fuchs can supply suitable preassembled M12 single-ended female cordsets () or field-attachable M12 female connectors and data cables.

Data Cable WCS-DC*

There are two types of data cable available:

- **WCS-DCS** for stationary cable routing
- **WCS-DCF** for routing trailing cables and drag chains.

The data cables are twisted pairs and have a tinned copper braided shield. The braided shield surrounds all wire pairs. The parameters of the data cables suitable for RS-485, SSI, and CANopen data transfer are listed in the table below.

	WCS-DCS	WCS-DCF
Capacitance (core-core)	120 pF/m	60 pF/m
Cross section	0.14 mm ²	0.25 mm ²
Number of cores	6 (3 x 2)	6 (3 x 2)
External diameter	5.8 mm	7.5 mm
Temperature range	-40 ... 80 °C	-40 ... 70 °C

Cable Routing

The basic prerequisite for uninterrupted data transfer is that the data cables are routed in such a way that any coupling of electromagnetic fields and interference is excluded. For EMC-compliant cable routing, it is necessary to divide the cables into cable groups and route these groups separately.

Group A

- Shielded data cable (including analog)
- Unshielded cable for DC and AC voltages 0 ... 60 V
- Shielded cable for DC and AC voltages 0 ... 230 V
- Coaxial cables for monitors

Group B

- Unshielded cable for DC and AC voltages 60 ... 400 V

Group C

- Unshielded cable for DC and AC voltages greater than 400 V

Shielding Cables

The shielding of cables is required to suppress electromagnetic interference. Establishing a low resistance or low impedance connection with the protective conductor is a particularly important factor in ensuring that these interference currents do not become a source of interference themselves.

The WCSB2B and WCS3B read heads have no connection option for the cable shield. The cable shield is connected to the plant potential in the switch cabinet with low resistance (large area). In the case of high electromagnetic interference, it is advisable to connect the shield of the data cable to the plant potential in the immediate vicinity of the read head with low resistance using a grounding clip.

Cable Length

For the RS-485 data transfer path, a four-wire, shielded, twisted pair data cable must be used. One core pair is used for the supply voltage, and one pair for the RS-485 data connection. The maximum length of the cable depends on the capacitance of the data cable—core-core—for data transfer, and on the cross section of the cables for voltage supply to the read heads. For data transfer, a small core cross section and thus a small cable capacitance is an advantage, whereas for the voltage supply, the largest possible cross section is required. The table below shows the possible cable lengths depending on the cable cross section.

Cable cross section	AWG ¹	Number of read heads without heater				Number of read heads with heater			
		1	2	3	4	1	2	3	4
0.14 mm ²	~ 26	200 m	110 m	70 m	50 m	15 m	10 m	7 m	5 m
0.22 mm ²	~ 24	320 m	170 m	110 m	80 m	30 m	15 m	10 m	7 m
0.25 mm ²	-	350 m	190 m	130 m	90 m	35 m	17 m	12 m	8 m
0.28 mm ²	-	400 m	220 m	150 m	110 m	40 m	20 m	15 m	10 m
0.34 mm ²	~ 22	500 m	250 m	180 m	140 m	50 m	25 m	17 m	12 m
0.50 mm ²	~ 20	500 m	400 m	270 m	200 m	70 m	35 m	25 m	17 m

1. American Wire Gauge, a system commonly used in North America for the specification of wire diameters in electrical engineering.

In the calculations, the worst-case scenario was assumed: All read heads are located at the end of the data cable. In the case of large cable lengths, and when connecting multiple WCS2 read heads with a heater, 6-wire data cables (3 x 2) can be used. These data cables use two pairs for the voltage supply (doubling the cable cross section), and one pair for the RS-485 data line. The table below shows the possible cable lengths depending on the cable capacitance (core-core). The number of connected read heads is of no significance.

Capacitance (core-core)	RS-485 interface		
	19.2 kb	62.5 kb	187.5 kb
60 pF	500 m	500 m	300 m
90 pF	500 m	450 m	275 m
120 pF	500 m	400 m	250 m

Cable Overview

The cable types listed below represent a selection of the types available from Pepperl+Fuchs. You can find additional cable types on our website.



Note

For customizable cables, observe the cable length restrictions specified by the interface specifications. Refer to the relevant interface chapters for maximum cable length recommendations.

RS-485 (LS1xx*, LS2xx*)

Cable	Description
Field attachable cable	
V15-G-2M-PUR-ABG	M12 single-ended female cordset, 5-pin, straight, 2 m PUR cable, shielded
V15-G-5M-PUR-ABG	M12 single-ended female cordset, 5-pin, straight, 5 m PUR cable, shielded
V15-G-10M-PUR-ABG	M12 single-ended female cordset, 5-pin, straight, 10 m PUR cable, shielded
Field attachable single-ended female cordsets and available by the meter	
V15-G-ABG-PG9	M12 single-ended female cordset, 5-pin, straight, field attachable, shielded
V15-G-ABG-PG9-FE	M12 single-ended female cordset, 5-pin, straight, field attachable, shielded with grounding terminal
V15-G-PG9	M12 single-ended female cordset, 5-pin, straight, field attachable
V15-W-PG9	M12 single-ended female cordset, 5-pin, angled, field attachable
WCS-DCS	Available by the meter, 6-pin data cable + shield, 0.14 mm ² 3 x 2 twisted core pair
WCS-DCF	Available by the meter, 6-pin data cable + shield, 0.25 mm ² 3 x 2 twisted core-pair, suitable for drag chains

Your automation, our passion.

Explosion Protection

- Intrinsic Safety Barriers
- Signal Conditioners
- FieldConnex® Fieldbus
- Remote I/O Systems
- Electrical Ex Equipment
- Purge and Pressurization
- Industrial HMI
- Mobile Computing and Communications
- HART Interface Solutions
- Surge Protection
- Wireless Solutions
- Level Measurement

Industrial Sensors

- Proximity Sensors
- Photoelectric Sensors
- Industrial Vision
- Ultrasonic Sensors
- Rotary Encoders
- Positioning Systems
- Inclination and Acceleration Sensors
- Fieldbus Modules
- AS-Interface
- Identification Systems
- Displays and Signal Processing
- Connectivity

Pepperl+Fuchs Quality

Download our latest policy here:

www.pepperl-fuchs.com/quality

