

VBA-4E4A-G20-ZEJ/M3L-P9

AS-Interface motor control module

Manual



With regard to the supply of products, the current issue of the following document is applicable:
The General Terms of Delivery for Products and Services of the Electrical Industry, published
by the Central Association of the Electrical Industry (Zentralverband Elektrotechnik und Elek-
troindustrie (ZVEI) e.V.) in its most recent version as well as the supplementary clause:
"Expanded reservation of proprietorship"

Worldwide

Pepperl+Fuchs Group
Lilienthalstr. 200
68307 Mannheim
Germany
Phone: +49 621 776 - 0
E-mail: info@de.pepperl-fuchs.com

North American Headquarters

Pepperl+Fuchs Inc.
1600 Enterprise Parkway
Twinsburg, Ohio 44087
USA
Phone: +1 330 425-3555
E-mail: sales@us.pepperl-fuchs.com

Asia Headquarters

Pepperl+Fuchs Pte. Ltd.
P+F Building
18 Ayer Rajah Crescent
Singapore 139942
Phone: +65 6779-9091
E-mail: sales@sg.pepperl-fuchs.com
<https://www.pepperl-fuchs.com>

1	Introduction.....	4
1.1	Content of this Document.....	4
1.2	Target Group, Personnel	4
1.3	Symbols Used	5
1.4	Intended Use	5
1.5	General Safety Information.....	6
1.6	Declaration of Conformity.....	6
2	Certificates and approvals.....	7
2.1	UL Information	7
3	Product Description	8
3.1	Use and application.....	8
3.2	Housing.....	8
3.3	Displays and operating elements	9
3.4	Interfaces and connections	11
3.5	Accessories.....	12
4	Installation.....	13
4.1	Storage and Transportation	13
4.2	Unpacking	13
4.3	Connecting the AS-Interface and Auxiliary Power Flat Cable.....	13
4.4	Connecting motors and sensors.....	16
5	Commissioning.....	17
5.1	AS-Interface communication.....	17
5.2	Configuring the start/stop ramps.....	19
6	Troubleshooting.....	23

1 Introduction

1.1 Content of this Document

This document contains information required to use the product in the relevant phases of the product life cycle. This may include information on the following:

- Product identification
- Delivery, transport, and storage
- Mounting and installation
- Commissioning and operation
- Maintenance and repair
- Troubleshooting
- Dismounting
- Disposal



Note

For full information on the product, refer to the further documentation on the Internet at www.pepperl-fuchs.com.

The documentation comprises the following parts:

- This document
- Datasheet

In addition, the documentation may comprise the following parts, if applicable:

- EU-type examination certificate
- EU declaration of conformity
- Attestation of conformity
- Certificates
- Control drawings
- Instruction manual
- Other documents

1.2 Target Group, Personnel

Responsibility for planning, assembly, commissioning, operation, maintenance, and dismantling lies with the plant operator.

Only appropriately trained and qualified personnel may carry out mounting, installation, commissioning, operation, maintenance, and dismantling of the product. The personnel must have read and understood the instruction manual and the further documentation.

Prior to using the product make yourself familiar with it. Read the document carefully.

1.3 Symbols Used

This document contains symbols for the identification of warning messages and of informative messages.

Warning Messages

You will find warning messages, whenever dangers may arise from your actions. It is mandatory that you observe these warning messages for your personal safety and in order to avoid property damage.

Depending on the risk level, the warning messages are displayed in descending order as follows:



Danger!

This symbol indicates an imminent danger.

Non-observance will result in personal injury or death.



Warning!

This symbol indicates a possible fault or danger.

Non-observance may cause personal injury or serious property damage.



Caution!

This symbol indicates a possible fault.

Non-observance could interrupt the device and any connected systems and plants, or result in their complete failure.

Informative Symbols



Note

This symbol brings important information to your attention.



Action

This symbol indicates a paragraph with instructions. You are prompted to perform an action or a sequence of actions.

1.4 Intended Use

The AS-Interface motor control module is used to control one or two DC roller Interroll EC310 motors or compatible types. The motor control module has two inputs for connecting three-wire sensors.

Read through these instructions thoroughly. Familiarize yourself with the device before installing, mounting, or operating.

Always operate the device as described in these instructions to ensure that the device and connected systems function correctly. The protection of operating personnel and plant is guaranteed only if the device is operated in accordance with its intended use.

1.5 General Safety Information

Responsibility for planning, assembly, commissioning, operation, maintenance, and dismantling lies with the plant operator.

Installation and commissioning of all devices may be performed only by trained and qualified personnel.

It is dangerous for the user to make changes and/or repairs. Additionally, doing so voids the warranty and excludes the manufacturer from any liability. In the event of any serious errors, stop using the device. Secure the device against unintended operation. To have the device repaired, return it to your local Pepperl+Fuchs representative or your sales center.

Note

Disposal

Electronic waste is dangerous. When disposing of the equipment, observe the current statutory requirements in the relevant country of use and local regulations.

1.6 Declaration of Conformity

This product was developed and manufactured in line with the applicable European standards and directives.

Note

A declaration of conformity can be requested from the manufacturer.

The product manufacturer, Pepperl+Fuchs Group, 68307 Mannheim, Germany, has a certified quality assurance system that conforms to ISO 9001.



2 Certificates and approvals

2.1 UL Information

Technical Data and Environmental Conditions

This device is for indoor use only.

This device may be operated in altitudes up to 2000 m.

The ambient temperature range is from -25 °C to +70 °C.

The device must be installed in accordance with applicable national laws and regulations.

If the device is used in a manner not specified by the manufacturer, the protection provided by the equipment may be impaired.

The device is maintenance-free.

3 Product Description

3.1 Use and application

The VBA-4E4A-G20-ZEJ/M3L-P9 motor control module is an AS-Interface connection module for controlling 1 or 2 DC roller motors. The module is optimized for Interroll EC310 motors, but can also be used for compatible DC motors.

To record statuses in the field environment, the module also has 2 inputs for 3-wire sensors with PNP outputs or for mechanical contacts. The input characteristic of the inputs corresponds to type 1 in accordance with EN 61131-2.

The motors are supplied with power via an external auxiliary voltage. Sensors are supplied from the AS-Interface. The auxiliary voltage is supplied to the motor control module via a 2nd flat cable in addition to the AS-Interface flat cable.

- The permissible auxiliary current is 18 V ... 30 V.
- The sensor power supply may be loaded, in total, with 100 mA.
- For each motor, a maximum current load of 5 A is permitted briefly (< 2 s).



Figure 3.1 VBA-4E4A-G20-ZEJ/M3L-P9 motor control module

Essential function and application characteristics of the motor control module are:

- Compact housing for direct mounting in support profiles or cable ducts
- Connection of the motors/sensors via cable outputs with M8 connectors
- Piercing technology with gold-plated contact pins for contacting the AS-Interface flat cable
- Function displays for the bus, external auxiliary current, status information, inputs, and outputs
- Communication monitoring
- Configurable start/stop ramps for motor control
- Supply of the connected motors from the external auxiliary current
- Supply of the connected sensors from the AS-Interface

3.2 Housing

The housing is made entirely of plastic, except for the hinge pins for the hinged cable guide.

The housing consists of following main components:

- a mounting base with embedded electronics
- a folding guide cage as a cable guide for the AS-Interface flat cable

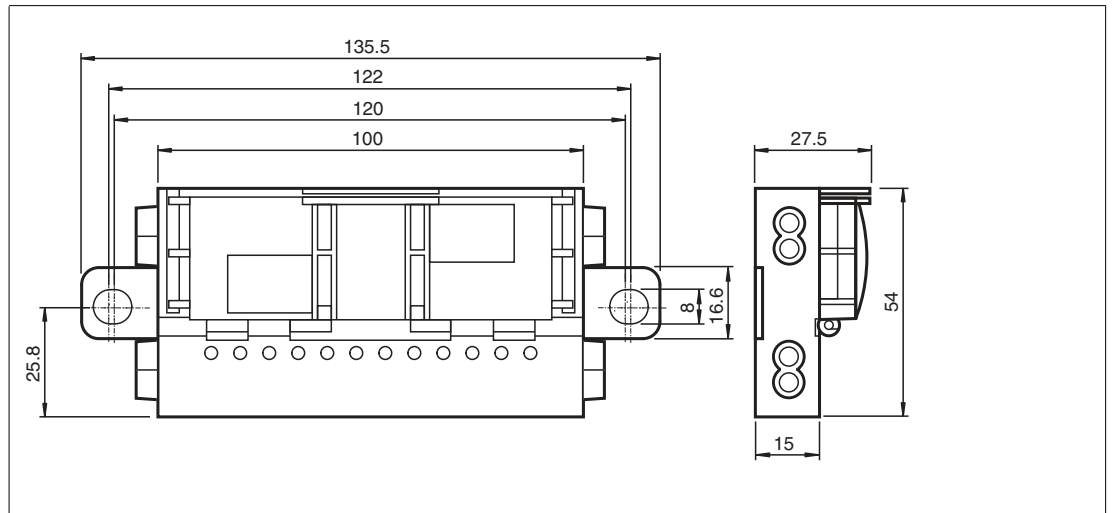

Figure 3.2 Housing dimensions

3.3 Displays and operating elements

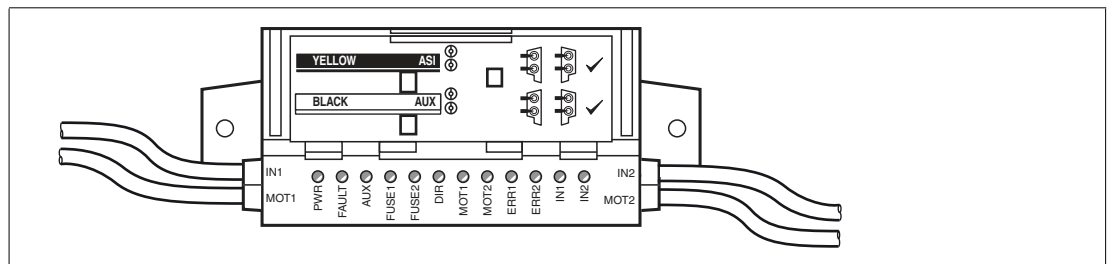

Figure 3.3 Status indicators on the motor control module

The operating state of the motor control module is displayed via 12 LEDs.

Status indicators for AS-Interface and power supply

The PWR LED and the FAULT LED show the AS-Interface operating state. Various error states are displayed as a collective error message "Peripheral fault."

Display of the AS-Interface operating states

LED PWR Green	LED FAULT Red	Status
On	Off	AS-Interface power supply is OK
Flashing	On	Address = 0
On	On	AS-Interface communication error
Flashing	Flashing	Peripheral fault, collective error message for: <ul style="list-style-type: none"> AUX external auxiliary power is missing or is inverted Overload of the sensor supply (IN+, IN-) Overload of the speed signal SPEED
Off	Off	AS-Interface voltage missing

The AUX LED shows the status of the AUX external auxiliary voltage supply.

Display of the AUX External auxiliary voltage supply

AUX LED Red/green	Status
Green on	AUX external auxiliary voltage is OK
Red on	AUX external auxiliary voltage is inverted
Off	AUX external auxiliary voltage is missing

Status indicators for motor fuses

The FUSE1 LED for motor 1 and the FUSE2 LED for motor 2 show the status of the power supplied to the motors.

Motor fuse Indicator

LED FUSE1 LED FUSE2 Green	Status
On	Power supply for motor is OK
Off	Power supply for motor is missing: <ul style="list-style-type: none"> Fuse is faulty or AUX external auxiliary voltage is not connected

Table 3.1

**Note****Motor fuses Are safety fuses**

Fuses with a 5 A rated current act as protection against short circuits. Each motor is safeguarded with a fuse. The fuses are not exchangeable. If a fuse is faulty, the module must be replaced.

Status indicators for motors MOT1, MOT2

The MOT1, MOT2, ERR 1, ERR2, and DIR LEDs display information about the operating states of the respective motor.

Motor activity indicators

LED MOT1 LED MOT2 Yellow	Status
On	Motor is in operation
Off	Motor is off

Table 3.2

Motor fault indicators

LED ERR1 LED ERR2 Yellow	Status
On	Motor fault is present: <ul style="list-style-type: none"> Fault indication output of the motor is active or No motor is connected or Fuse is faulty
Off	No motor fault

Table 3.3

Motor direction of rotation indicator

LED DIR Yellow	Status
On	Direction of rotation to the right (in accordance with EC310)
Off	Direction of rotation to the left (in accordance with EC310)

Table 3.4

Status indicators for IN1, IN2 sensors

The IN1 LED for input 1 and IN2 LED for input 2 show the switch states of the inputs.

Display of the Inputs

IN1 LED IN2 LED Yellow	Status
On	Input is set (high)
Off	Input is not set (low)

Table 3.5

3.4 Interfaces and connections

Flat cable specification

The AS-Interface motor control module is compatible with the AS-Interface standard cable in accordance with IEC 62026-2.

The following AS-Interface cable types are available with UL Recognized approval:

AS-Interface cable types with UL approval

Pepperl+Fuchs Designation	Color	Sheathing material/ core insulation	Cross section	UL "Cable Style"	Approval
VAZ-FK-R-YE	Yellow	TPE/TPE	2x 1.5 mm	2103	
VAZ-FK-R-BK	Black	TPE/TPE	2x 1.5 mm	2103	
VAZ-FK-PUR-YE	Yellow	PUR(TMPU)/TPM	2x 1.5 mm	20549	
VAZ-FK-PUR-BK	Black	PUR(TMPU)/TPM	2x 1.5 mm	20549	
VAZ-FK-PUR-BK-2,5MM	Black	PUR(TMPU)/TPM	2x 2.5 mm	20549/10493	

Table 3.6

Input/Output connections

The sensors and motors are connected to the motor control module via cables with round M8 connectors:

- Sensors: socket, 4-pin
- Motors: socket, 5-pin

The cable length is 1 m.

Motor supply from auxiliary current

The motors are supplied with power directly from the AUX external auxiliary current and this cannot be switched. The voltage is always on contacts 1 and 3 of the 5-pin M8 connector.

Connector Assignment

Connection for	Connectors	Plug type/plug assignment
Sensor		Input: in accordance with IEC/EN 61076-2-104 M8, 4-pin, socket, screw-locking, coding A Suitable counterpart connector: M8, 4-pin, plug, screw-locking, coding A IN1/IN2 1: IN+ sensor supply 2: Not used 3: IN- sensor supply 4: IN input
Motor		Motor: in accordance with IEC/EN 61076-2-104 M8, 5-pin, socket, snap-locking, coding B Suitable counterpart connector: M8, 5-pin, plug, snap-locking, coding B 1: MOT+ motor supply 2: DIR direction of rotation 3: MOT- (= AUX-) motor supply 4: ERROR motor fault 5: SPEED velocity signal

Table 3.7

3.5 Accessories

Various accessories are available.

Product	Product name
VBP-HH1-V3.0-KIT	AS-Interface Handheld with accessory
VAZ-PK/G20-1M-V1-G	Adapter cable G20 module/hand-held programming device
VAZ-G20-MH	Mounting aid

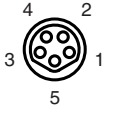
Table 3.8

4 Installation

4.1 Storage and Transportation

Keep the original packaging. Always store and transport the device in the original packaging. Store the device in a clean and dry environment. The permitted ambient conditions must be considered, see datasheet.

4.2 Unpacking

Check the product for damage while unpacking. If the product should be damaged, inform the post office or parcel service and notify the supplier.

Retain the original packaging in case the device must be stored or shipped again at a later date.

Should you have any questions, please contact Pepperl+Fuchs.

4.3 Connecting the AS-Interface and Auxiliary Power Flat Cable

The motor control module is connected to the AS-Interface network and the AUX auxiliary power via the AS-Interface flat cable. The yellow flat cable is for communication and the black flat cable is for the AUX auxiliary power. The permissible auxiliary power is 18 V ... 30 V.

Contact between the motor control module and flat cables is established via two metal mandrels and using insulation piercing technology. The flat cables are routed through a hinged cable guide. When closed, the cable guide is locked using a locking bracket and can be opened again without the needs for tools.

The profiled flat cables have a narrow upper side (with a visibly offset profile edge) and a wide under side (profile edge not visible). The cable guide allows the flat cables to be inserted on both sides, for flexible connection of flat cables already laid in cable ducts. However, you must make sure that the profile edge always points to the motor control module. Mechanical reverse polarity protection prevents complete closure of the cable guide if the flat cable is inserted incorrectly.



Caution!

If one is inserted incorrectly, the motor control module will not work.

If the flat cable is inserted in the cable guide in the wrong direction, the voltage is inverted. The motor control module will not work. However, internal electrical reverse polarity protection protects it against breakage.



Connecting Flat Cables on the Narrow Side

The profile edge is visible from above.

1. Open the cable guide. To do this, push the locking bracket (1) slightly to one side.
2. Insert the black AUX flat cable with the profile edge (4) to the motor control module into the lower guide (see the module tag "Black AUX").
3. Insert the yellow AS-Interface flat cable with the profile edge (3) to the motor control module into the upper guide (see the module tag "YELLOW").
4. Make sure that the profile edges of both flat cables are under the respective reverse polarity protection (2, 5).



Tip

For easier closing of the cable guide, use mounting aid VAZ-G20-MH.

5. Close the cable guide. It must engage securely in the locking bracket (1).

↳ The metal mandrels contact the strands in the flat cables.

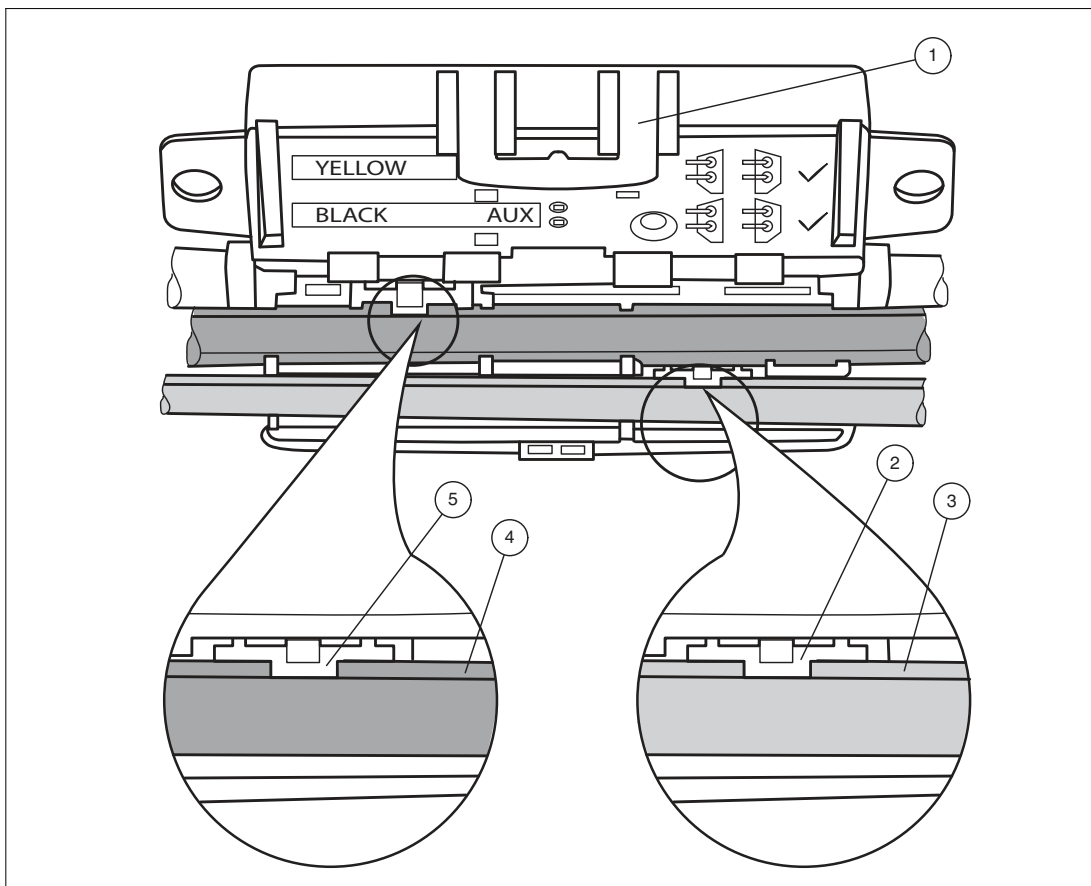

Figure 4.1 Connecting Flat Cables on the Narrow Side



Connecting Flat Cables on the Wide Side

The profile edge is not visible from above. For orientation purposes in the figure below, the edge is shown as a hidden edge drawn with a dotted line.

1. Open the cable guide. To do this, push the locking bracket (1) slightly to one side.
2. Insert the black AUX flat cable with the profile edge (3) to the motor control module into the lower guide (see the module tag "Black AUX").
3. Insert the yellow AS-Interface flat cable with the profile edge (2) to the motor control module into the upper guide (see the module tag "YELLOW").



Tip

For easier closing of the cable guide, use mounting aid VAZ-G20-MH.

4. Close the cable guide. It must engage securely in the locking bracket (1).

↳ The profile edges (2, 3) of both flat cables are above the two reverse polarity protections. The metal mandrels contact the strands in the flat cables.

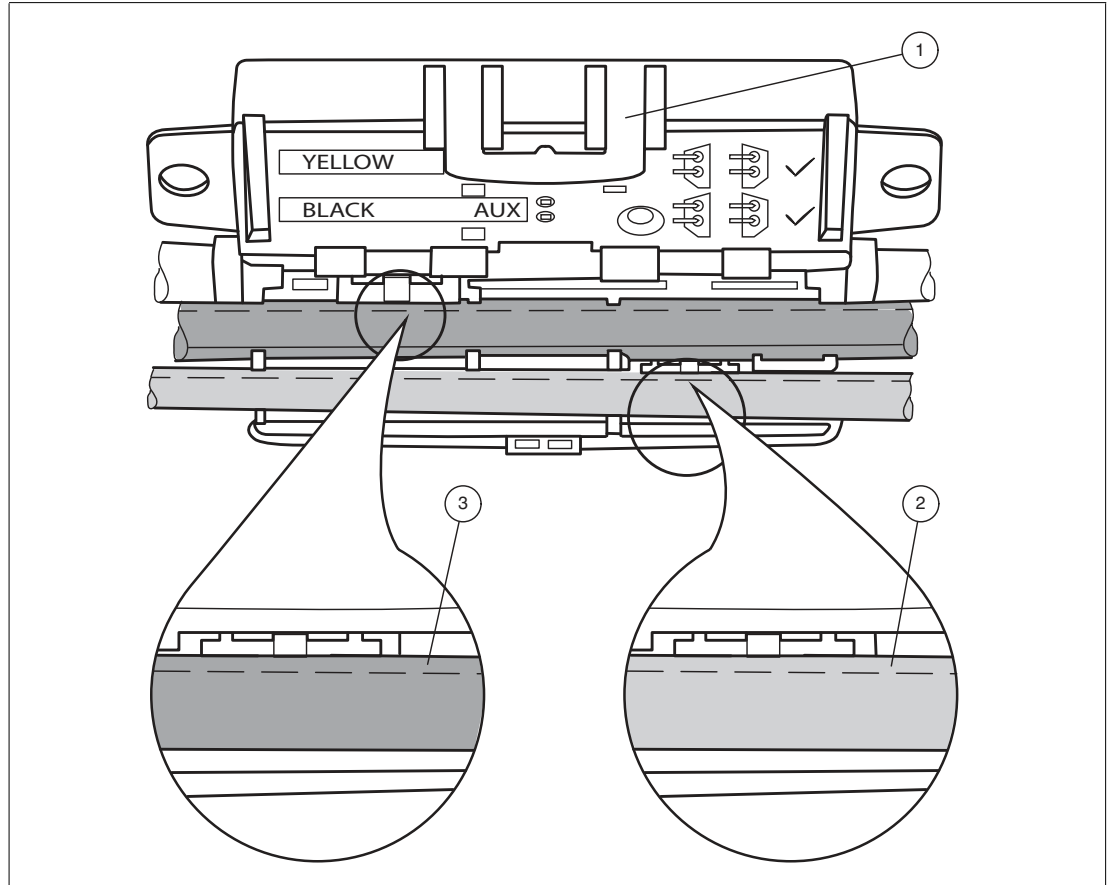

Figure 4.2 Connecting flat cables on the wide side (profile edge as dotted line)

Flat Cable Inserted Incorrectly

The figure below shows an incorrectly inserted flat cable. The profile edge (2) does not point to the motor control module; the flat cable is therefore inserted with reverse polarity. The flat cable is located on the reverse polarity protection (1) with a curvature, which means that the cable guide cannot be closed completely (mechanical reverse polarity protection).

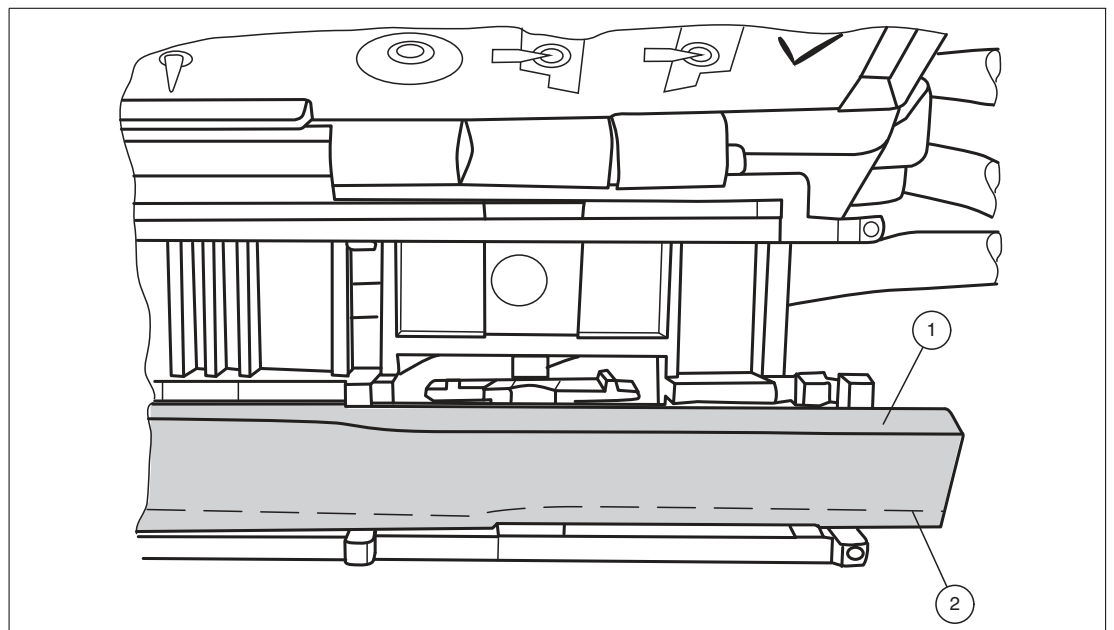

Figure 4.3 Flat cable inserted incorrectly (profile edge as dotted line)

4.4 Connecting motors and sensors

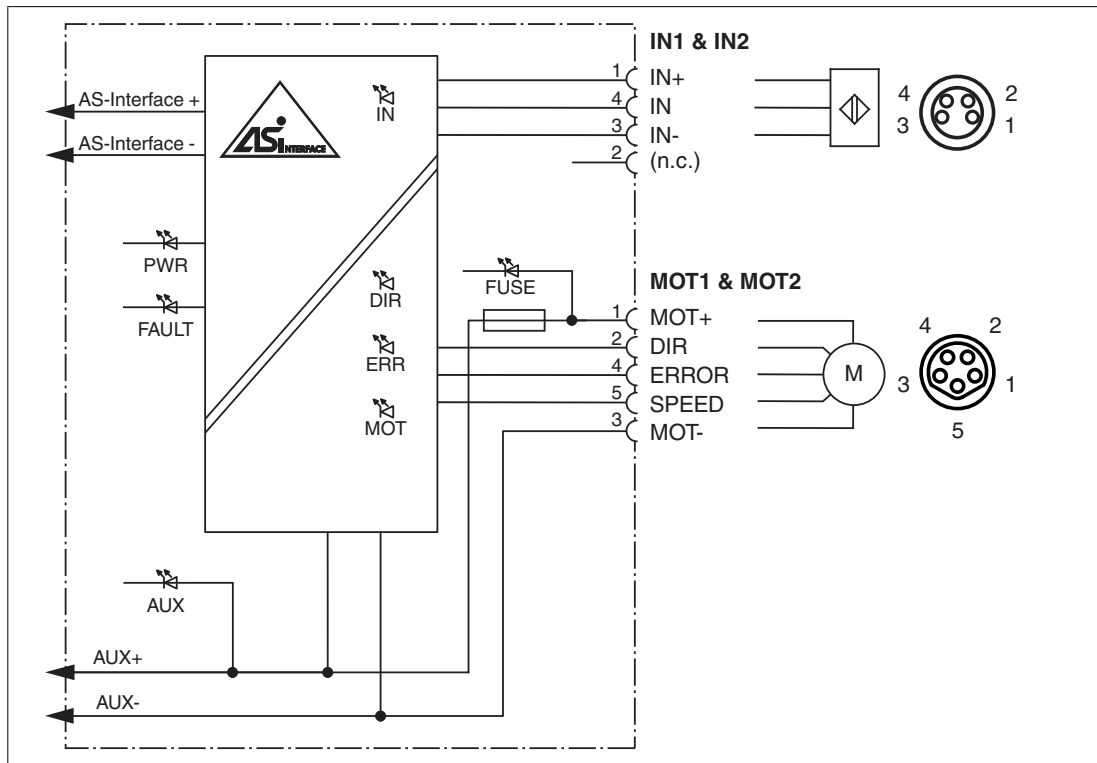

Figure 4.4 Connection wiring diagram for motors and sensors

5 Commissioning

AS-Interface slaves are usually addressed with a handheld. Connect the adapter cable VAZ-PK/G20-1M-V1-G to the handheld VBP-HH1-V3.0.

5.1 AS-Interface communication

Assignment of AS-Interface data bits

4 data bits are available for communication to take place between the motor control module and the master. 4 data bits are available for controlling the motors.

The following designations apply below:

- DI0 ... DI3 for AS-Interface input data (motor control module to master)
- DO0 ... DO3 for AS-Interface output data (master to motor control module)

DI0 ... DI3 motor control module to master

AS-Interface data bit	Input DI
DI0	Switch state input IN1
DI1	Switch state input IN2
DI2	Fault at output MOT1
DI3	Fault at output MOT2

Table 5.1

DO0 ... DO3 master to motor control module

AS-Interface data bit	Output DO
DO0	Start/stop motor 1
DO1	Start/stop motor 2
DO2	Direction of rotation of motor 1 and motor 2
DO3	Slow rotational speed of motor 1 and motor 2

Table 5.2

AS-Interface communication monitoring

The motor control module has a watchdog function. If there has been no communication with the master for more than 40 ms, the motor control module sets the output data DO0 ... DO3 to logical 0.

Starting/Stopping motors (DO0, DO1)

You can start or stop the motors separately via bits DO0 and DO1. To start motors, you must set the corresponding data bit to logical 1. Via the shared SPEED control signal, the motor control module uses an analog voltage value to actuate the respective motor that has been switched on. The SPEED control signal is released for the relevant output only when data bit DO0 or DO1 is set. The analog voltage value corresponds to the set speed.

Data bits DO0, DO1

Data bit	Status	Function	LED MOT1/2
DO0	1	Start motor 1 (SPEED > 1.5 V)	MOT1: on
	0	Stop motor 1 (SPEED < 1.5 V)	MOT1: off
DO1	1	Start motor 2 (SPEED > 1.5 V)	MOT2: on
	0	Stop motor 2 (SPEED < 1.5 V)	MOT2: off

Table 5.3

Switching the motor direction of rotation (DO2)

You can switch the direction of rotation of the motors using the DIR control signal. The direction of rotation signal applies to both motors. To control the direction of rotation, you must parameterize data bit DO2 accordingly.

For Interroll EC310, logical 0 corresponds to a direction of rotation to the left. The motor control module switches the DIR control signal to high impedance.

For Interroll EC310, logical 1 corresponds to a direction of rotation to the right. The motor control module switches the DIR control signal to AUX level.

You can reverse direction of rotation of motor 2 by setting parameter bit P2 to logical 0. Motor 2 will then rotate in opposite direction of motor 1.

Data bit DO2, parameter bit P2

Parameter bit	Data bit	Direction of rotation		Direction of rotation signal		LED DIR
P2	DO2	Motor 1	Motor 2	DIR 1	DIR 2	Yellow
0	0	left	right	High impedance, approx. 0 V	$\geq (U_{AUX} - 2.5 \text{ V})$	off
0	1	right	left	$\geq (U_{AUX} - 2.5 \text{ V})$	High impedance, approx. 0 V	on
1	0	left	left	High impedance, approx. 0 V	High impedance, approx. 0 V	off
1	1	right	right	$\geq (U_{AUX} - 2.5 \text{ V})$	$\geq (U_{AUX} - 2.5 \text{ V})$	on

Table 5.4

Switching the motor speed (DO3)

You can switch both motors to a slow speed via data bit DO3. The slow speed is determined based on the set speed.

Data bit DO3

Data bit	Status	Function
DO3	0	fast speed
	1	slow speed

Table 5.5

Adjusting the motor speed (P0, P1)

You can adjust the speed via parameter bits P0 and P1. This always applies to both motors simultaneously. To do this, you must parameterize 1 of 4 predefined speed values. The speed values correspond to analog voltage values.

If the master does not change the parameter bits when the AS-Interface network is switched on, the 4th speed value (10 V) is set by default on the motor control module.

Using data bit DO3, you can switch the speed of both motors between fast and slow.

The motor control module issues the set control voltage to the motors via the SPEED control signal when the motors are switched on via data bits DO0 and DO1 (logical 1). The motor control module readjusts the control voltage. Therefore the control voltage is independent of the load within certain limits. If the control limits are exceeded due to an excessive load, the motor control module issues a peripheral fault.

Parameter bits P0, P1

Parameter bit		DO0 (MOT1) or DO1 (MOT2)	Speed signal U_S	
P1	P0		Fast (D3 = 0)	Slow (D3 = 1)
x	x	0	< 1 V	< 1 V
0	0	1	6.44 V	3.96 V
0	1	1	7.26 V	4.28 V
1	0	1	8.5 V	4.78 V
1	1	1	10 V	5.61 V

Table 5.6

Reversing the direction of rotation of MOT2 (P2)

You can reverse the direction of rotation of MOT2 via parameter bit P2.

Parameter bit P2

Parameter bit	Status	Function
P2	0	counter-rotating, direction of rotation of MOT2 inverted
	1	synchronized, direction of rotation of MOT1 = direction of rotation of MOT2 (default setting)

Table 5.7

Status of the sensor inputs (DI0, DI1)

The motor control module transfers the switch states of inputs IN1 and IN2 to the master via data bits DI0 (IN1) and DI1 (IN2).

There is a filter upstream of the inputs that suppresses pulses ≤ 2 ms.

Data bits DI0, DI1

Data bit	Status	Input switch state	LEDs IN1, IN2
DI0	0	Unattenuated, $I_{IN} \leq 0.5$ mA	IN1: off
	1	Attenuated, $I_{IN} \geq 2.0$ mA	IN1: on
DI1	0	Unattenuated, $I_{IN} \leq 0.5$ mA	IN2: off
	1	Attenuated, $I_{IN} \geq 2.0$ mA	IN2: on

Table 5.8

5.2 Configuring the start/stop ramps

Overview

To control the acceleration and to stop the motors, you can set 1 of 8 defined start/stop ramps for the speed signal SPEED. These ramps always apply to both motors simultaneously. The ramp duration corresponds to the time from stopped to reaching the maximum speed or from the maximum speed to stopped. The inclines of the ramps are constant for each of the 8 ramps and independent of the set speed. The reference value for all ramps is the speed signal SPEED = 10 V. For a lower parameterized speed, the ramp duration is proportionally shorter.

Predefined start/stop ramps

Ramp number	Ramp duration
0	No ramp (default setting)
1	50 ms
2	100 ms
3	200 ms
4	300 ms
5	500 ms
6	1000 ms
7	1500 ms

Table 5.9

The ramp is not effective if the direction of rotation signal is switched when the motor is active. In this case, the direction of rotation is reversed immediately.

Note**Default Setting on Delivery**

On outbound delivery, ramp number 0 (no ramp) is the default.

Configuring start/stop ramps

To adjust the start/stop ramp, you must change the motor control module to configuration mode. The motor control module stores a new ramp configuration in the internal non-volatile memory. This ramp is activated automatically after each switch-on. You can reconfigure a ramp as often as required.

A prerequisite for configuration is that the flat cables for the AS-Interface and AUX are connected. Communication must already be taking place between the master and motor control module.

Note**Configuration mode display via LEDs**

If the motor control module is in configuration mode, the MOT1 and MOT2 LEDs flash simultaneously at a frequency of approximately 2 Hz.

The configuration sequence consists of 9 steps. As part of this, defined data is transferred via data bits DO0 ... DO3 and parameter bits P0 ... P2 between the master and the motor control module. The master must keep the data and parameter bits constant for at least 10 ms for each step. Longer intervals are possible as long as a period of 10 s is not exceeded for steps 1 ... 6.

The configuration of a new start/stop ramp runs in the following phases:

- In steps 1 ... 6, the master sends parameter values to the motor control module to activate configuration mode (max. 10 s). For each step, DO0 ... DO3 must have the value "4".
- When the motor control module is in configuration mode, MOT1 and MOT2 LEDs start to flash.
- In step 7, the master sends the selected ramp number to the motor control module via DO0 ... DO3.
- In step 8, the master sends the parameter value "4" to the motor control module via P0 ... P2. The motor control module stores the ramp number in the non-volatile memory.
- In step 9, the master exits configuration mode. The master sends data value "0" via DO0 ... DO3 and data value "7" via P0 ... P2. The motor control module switches to normal mode. The MOT1 and MOT2 LEDs stop flashing.

**Note****Sequence for command transmission**

For each step, you generally send the data value via DO0 ... DO3 first and then the parameter value P0 ... P2. The following table shows the contexts of communication between the master and motor control module. The value "x" represents any of the values in the table.

**Sequence for configuring a start/stop ramp**

Send the following data values and parameter values to the motor control module:

1. For each of steps 1 ... 6, send the data value "4" via DO0 ... DO3 and then via P0 ... P2, the corresponding value from the parameter sequence 3, 1, 6, 3, 1, 6.
2. If configuration mode is active, as step 7, send the required ramp number via DO ... DO3 and via P0 ... P2 the parameter value "6".
3. As step 8, send the ramp number again via DO0 ... DO3 and via P0 ... P2 the parameter value "4".
4. As step 9, send data value "0" via DO0 ... DO3 and via P0 ... P2 the parameter value "7".

↳ The motor control module has stored the new start/stop ramp and switched back to normal mode.

Contexts of module communication

Step	DO0 ... DO3	P0 ... P2	DI0 ... DI3	Comment
	≠ 4	x	x	Motor control module in normal mode
1	4	3	x	Start activation sequence for configuration mode
2	4	1	x	
3	4	6	x	
4	4	3	x	
5	4	1	x	
6	4	6	11xx = C ... F	End activation sequence for configuration mode
7	Ramp number	6	11xx = C ... F	The ramp number is transferred to the motor control module.
8	Ramp number	4	10xx = 8 ... B	The ramp is stored.
9	0	7	x	Motor control module switches back to normal mode.

Table 5.10

Troubleshooting during configuration

If a fault occurs during the 9-step configuration process, the following table describes the behavior of the motor control module.

Fault scenarios

Step	Possible fault	Motor control module reaction
1 ... 6	<ul style="list-style-type: none"> Incorrect data or parameter values or steps 1 ... 6 take longer than 10 s 	Motor control module remains in normal mode.
7 or 8	Incorrect data or parameter values	<ul style="list-style-type: none"> The motor control module changes to normal operation only when the master sends "0" via DO0 ... DO3 and "7" via P0 ... P2. If "0" or "7" has already been set by the master in one of these steps, the motor control module switches directly to normal operation. The stored ramp is not changed.

Table 5.11

6 Troubleshooting

Fault information and remedy

Error	LED status indicator	Possible cause	Remedy
No data communication with AS-Interface master	PWR off	AS-Interface voltage is missing or is inverted	Check AS-Interface wiring
	PWR flashes and FAULT on	Module address is 0	Program module address
	PWR on and FAULT on	AS-Interface master is not switched on (offline) or There is duplicate addressing	Switch on the AS-Interface master or Check the addresses of all modules on the AS-Interface segment
Motors do not start	AUX off	AUX external power supply is missing	Check AUX voltage and AUX flat cable
	AUX red on	AUX external power supply is inverted	Correct the polarity of the AUX flat cable in the cable guide
	AUX green on and FUSE1 (motor 1) and/or FUSE2 (motor 2) off	Motor fuse is faulty due to overload of the motor supply	Replace the motor control module (cannot be repaired) and remove the cause of the overload before starting the motor again
	PWR and FAULT flash alternately	Peripheral fault "Overload speed signal SPEED": Motor, motor cable, or motor control module is faulty	Replace motor or motor control module
Sensors or inputs IN1 ... IN2 not working	PWR and FAULT flash alternately	Periphery fault: overload on sensor supply	Check the sensors and eliminate the overload

Table 6.1

Your automation, our passion.

Explosion Protection

- Intrinsic Safety Barriers
- Signal Conditioners
- FieldConnex® Fieldbus
- Remote I/O Systems
- Electrical Ex Equipment
- Purge and Pressurization
- Industrial HMI
- Mobile Computing and Communications
- HART Interface Solutions
- Surge Protection
- Wireless Solutions
- Level Measurement

Industrial Sensors

- Proximity Sensors
- Photoelectric Sensors
- Industrial Vision
- Ultrasonic Sensors
- Rotary Encoders
- Positioning Systems
- Inclination and Acceleration Sensors
- Fieldbus Modules
- AS-Interface
- Identification Systems
- Displays and Signal Processing
- Connectivity

Pepperl+Fuchs Quality

Download our latest policy here:

www.pepperl-fuchs.com/quality

