

Distance Sensors

R1000

Manual



Your automation, our passion.

 **PEPPERL+FUCHS**

With regard to the supply of products, the current issue of the following document is applicable:
The General Terms of Delivery for Products and Services of the Electrical Industry, published
by the Central Association of the Electrical Industry (Zentralverband Elektrotechnik und Elek-
troindustrie (ZVEI) e.V.) in its most recent version as well as the supplementary clause:
"Expanded reservation of proprietorship"

Worldwide

Pepperl+Fuchs Group
Lilienthalstr. 200
68307 Mannheim
Germany
Phone: +49 621 776 - 0
E-mail: info@de.pepperl-fuchs.com

North American Headquarters

Pepperl+Fuchs Inc.
1600 Enterprise Parkway
Twinsburg, Ohio 44087
USA
Phone: +1 330 425-3555
E-mail: sales@us.pepperl-fuchs.com

Asia Headquarters

Pepperl+Fuchs Pte. Ltd.
P+F Building
18 Ayer Rajah Crescent
Singapore 139942
Phone: +65 6779-9091
E-mail: sales@sg.pepperl-fuchs.com
<https://www.pepperl-fuchs.com>

1	Introduction.....	5
1.1	Content of this Document.....	5
1.2	Target Group, Personnel	5
1.3	Symbols Used	5
2	Declaration of Conformity.....	7
3	Safety	8
3.1	Safety Notices	8
4	Product Description	9
4.1	R1000 Distance Sensors.....	9
4.2	Function Principle.....	9
4.3	Indicators and Operating Elements	10
4.4	Interfaces and Connections	10
4.5	Scope of Delivery.....	11
4.6	Accessories.....	11
5	Installation.....	12
5.1	Storage and Transport.....	12
5.2	Unpacking	12
5.3	Mounting.....	12
5.4	Reflector Selection	17
5.5	Reflector Arrangement.....	17
5.6	Device Connection.....	18
5.7	Grounding/Shielding	18
5.8	Notes for Parallel Operation of R1000 Series Devices and Optical Data Couplers.....	18
6	Commissioning.....	19
6.1	Display	19
6.1.1	Operating Indicator	19
6.1.2	Display Timeout.....	20

7	Settings	21
7.1	Operation	21
7.2	Menu Structure.....	22
7.3	Description of Menu Items	23
7.3.1	Measurement Menu Item	23
7.3.2	Menu Item Display	24
7.3.3	Serial Menu Item	25
7.3.4	Miscellaneous Menu Item	25
8	Troubleshooting	26
8.1	Error Message	26
8.2	Warning Message.....	27
9	Appendix	28
9.1	Description of Interfaces.....	28
9.1.1	General	28
9.1.2	SSI	28

1 Introduction

1.1 Content of this Document

This document contains information required to use the product in the relevant phases of the product life cycle. This may include information on the following:

- Product identification
- Delivery, transport, and storage
- Mounting and installation
- Commissioning and operation
- Maintenance and repair
- Troubleshooting
- Dismounting
- Disposal



Note

For full information on the product, refer to the further documentation on the Internet at www.pepperl-fuchs.com.

The documentation comprises the following parts:

- This document
- Datasheet

In addition, the documentation may comprise the following parts, if applicable:

- EU-type examination certificate
- EU declaration of conformity
- Attestation of conformity
- Certificates
- Control drawings
- Instruction manual
- Other documents

1.2 Target Group, Personnel

Responsibility for planning, assembly, commissioning, operation, maintenance, and dismantling lies with the plant operator.

Only appropriately trained and qualified personnel may carry out mounting, installation, commissioning, operation, maintenance, and dismantling of the product. The personnel must have read and understood the instruction manual and the further documentation.

Prior to using the product make yourself familiar with it. Read the document carefully.

1.3 Symbols Used

This document contains symbols for the identification of warning messages and of informative messages.

Warning Messages

You will find warning messages, whenever dangers may arise from your actions. It is mandatory that you observe these warning messages for your personal safety and in order to avoid property damage.

Depending on the risk level, the warning messages are displayed in descending order as follows:



Danger!

This symbol indicates an imminent danger.

Non-observance will result in personal injury or death.



Warning!

This symbol indicates a possible fault or danger.

Non-observance may cause personal injury or serious property damage.



Caution!

This symbol indicates a possible fault.

Non-observance could interrupt the device and any connected systems and plants, or result in their complete failure.

Informative Symbols



Note

This symbol brings important information to your attention.



Action

This symbol indicates a paragraph with instructions. You are prompted to perform an action or a sequence of actions.

2 Declaration of Conformity

This product was developed and manufactured in line with the applicable European standards and directives.



Note

A declaration of conformity can be requested from the manufacturer.

The product manufacturer, Pepperl+Fuchs Group, 68307 Mannheim, Germany, has a certified quality assurance system that conforms to ISO 9001.



3 Safety

3.1 Safety Notices

Read the following information carefully and follow this information when working with the device. Failure to observe the safety notices and warning messages in this documentation can lead to malfunctions and hazardous operating scenarios during operation.

This can result in serious personal injury or death.

Target Group, Personnel

The personnel must be appropriately trained and qualified in order to carry out mounting, installation, commissioning, operation, maintenance, and dismantling of the device. The trained and qualified personnel must have read and understood the instruction manual.

Prior to using the product make yourself familiar with it. Read the instruction manual carefully.

Reference to Further Documentation

Observe laws, standards, and directives applicable to the intended use and the operating location.

Intended Use

The device is only approved for appropriate and intended use. Ignoring these instructions will void any warranty and absolve the manufacturer from any liability.

Operation, Maintenance, Repair

Do not remove the nameplate.

Do not remove the warning markings.

Do not repair, modify, or manipulate the device.

If there is a defect, always send back the device to Pepperl+Fuchs.

If there is a defect, always replace the device with an original device.

Only use accessories specified by the manufacturer.

When using the device, observe the safety guidelines applicable to the applications.

Supply the device with a power supply that meets the requirements for safety extra-low voltage (SELV) or protective extra-low voltage (PELV).

Do not point the device directly at the sun.

Delivery, Transport, Disposal

Keep the original packaging. Always store and transport the device in the original packaging.

The device, built-in components, packaging, and any batteries contained within must be disposed in compliance with the applicable laws and guidelines of the respective country.

4 Product Description

4.1 R1000 Distance Sensors

The exact positioning of stock feeders, moving carriages, cranes, and handling machines, as well as the performance of length measurements in the woodworking industry, for concrete saws, and in elevator construction, requires distance sensors that are capable of returning measured values at a high measurement rate over large distances with millimeter precision.

Distance sensors are used wherever straight-line distances need to be determined precisely and reliably.

Optoelectronic distance sensors are almost wear-free and are easy to install.

Additional benefits offered by these devices are short assembly and commissioning times and the high degree of reliability of a photoelectric measuring system, as well as ease of replacement.

The available interface is:

- SSI (Synchronous Serial Interface)

The photoelectric sensors of the R1000 series meet the safety requirements of laser class 1 (EN 60825). The low amount of laser light emitted ensures that operating personnel are not injured or harmed.

4.2 Function Principle

The devices work according to the principle of pulse ranging technology (PRT). The device measures the time between sending a light pulse and receiving the reflected pulse. Due to the constancy of the speed of light, this time is a measurement of distance.

The light source and light receiver are located in the device. A reflector is required for measuring the distance, and must be installed opposite the device. By virtue of its technical features, Pulse Ranging Technology (PRT) is particularly well-suited for high-precision distance measurement over large distances compared to other methods of distance measurement.

In comparison to other distance measurement processes, time-of-flight measurement is largely independent of the measuring environment, and can therefore be used to a high degree of accuracy in harsh everyday industrial conditions.



Note

Influence of Ambient Conditions

The speed of light depends on the air temperature and barometric pressure.

The influence of the air temperature amounts to 1 ppm/K.

The influence of barometric pressure amounts to -0.3 ppm/hPa.

The user must take these factors into consideration when measuring long distances.

4.3 Indicators and Operating Elements

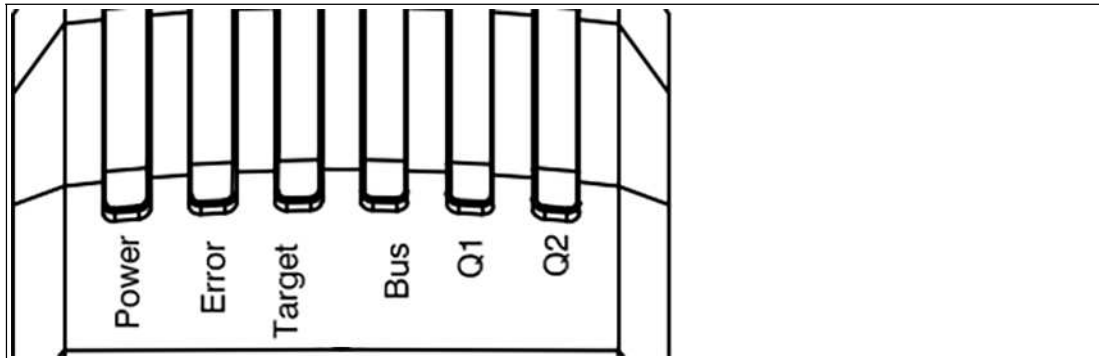

Figure 4.1 Indicators

Designation	Color	Description
Power	Green	Lights up when supplied with operating voltage
Error	Red	Lights up when there is an error; flashes in the event of a warning
Target	Yellow	Lights up when the sensor detects a reflector
Bus	Green	Signals interface activities
Q1		(No function)
Q2		(No function)

Signal indicators at the bottom of the housing do not have a function.



Figure 4.2 Display and arrow keys

4.4 Interfaces and Connections

The following connections are found on all devices:

Power Supply

There is a 4-pin M12 plug on the rear of the housing for connecting the power supply. The following diagram shows the pinout:



Figure 4.3 Power supply connection assignment

- | | |
|----------|-------------------|
| 1 | 24 V power supply |
| 2 | Do not connect |
| 3 | 0 V (GND) |
| 4 | Do not connect |

Interfaces:

Different connection types can be found on the back of the housing depending on what interface is used. The following diagrams show the pin assignments:

Connection interface: SSI (Synchronous Serial Interface)

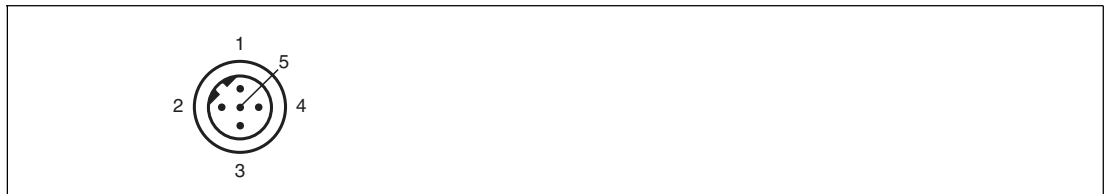

Figure 4.4 Connection Assignment SSI

- | | |
|----------|------|
| 1 | D+ |
| 2 | D- |
| 3 | CLK+ |
| 4 | CLK- |
| 5 | n.c. |

The connector housing is located on the shield.

4.5 Scope of Delivery

The scope of delivery includes:

- R1000
- Safety information and laser label
- Grounding set

4.6 Accessories

You will find accessories online at www.pepperl-fuchs.com on the product page for the relevant device or on the relevant datasheet.

5 Installation

5.1 Storage and Transport

Pack the device for storage and transport in a way that protects it against impact.

Protect the device against moisture.

Always store and transport the device in the original packaging.

Also take note of the permitted ambient conditions.



Note

In all cases, avoid subjecting the device to condensation, as this could have an effect on internal parts and cause damage.

5.2 Unpacking

Check the product for damage while unpacking. If the product should be damaged, inform the post office or parcel service and notify the supplier.

Retain the original packaging in case the device must be stored or shipped again at a later date.

Should you have any questions, please contact Pepperl+Fuchs.

5.3 Mounting



Caution!

Risk of damage due to improper operation.

Improper operation can result in damage to the device.

- Do not point the sensor into the sun.
 - Protect the sensor against direct and prolonged sunlight.
 - Prevent condensation from forming by ensuring that the sensor is not subjected to any major temperature fluctuations.
 - Do not subject the sensor to any influences caused by aggressive chemicals.
In particular, avoid agents that contain hydrocarbons, such as mineral spirits, alcohol, and solvents.
 - Keep the glass on the device and the reflector clean.
Use soft cloths. If necessary, clean the glass with water and a small amount of dish detergent.
-



Note

Use M6 mounting screws with 8 mm thread length.

Mounting Aid

The mounting aid OMH-R1000-02 enables fine adjustment. To align the laser beam of the device on the reflector as centrally as possible, the device can be adjusted by $\pm 2.5^\circ$ along the Y-axis or Z-axis using the fixture.



Mounting the Fixture on the Wall

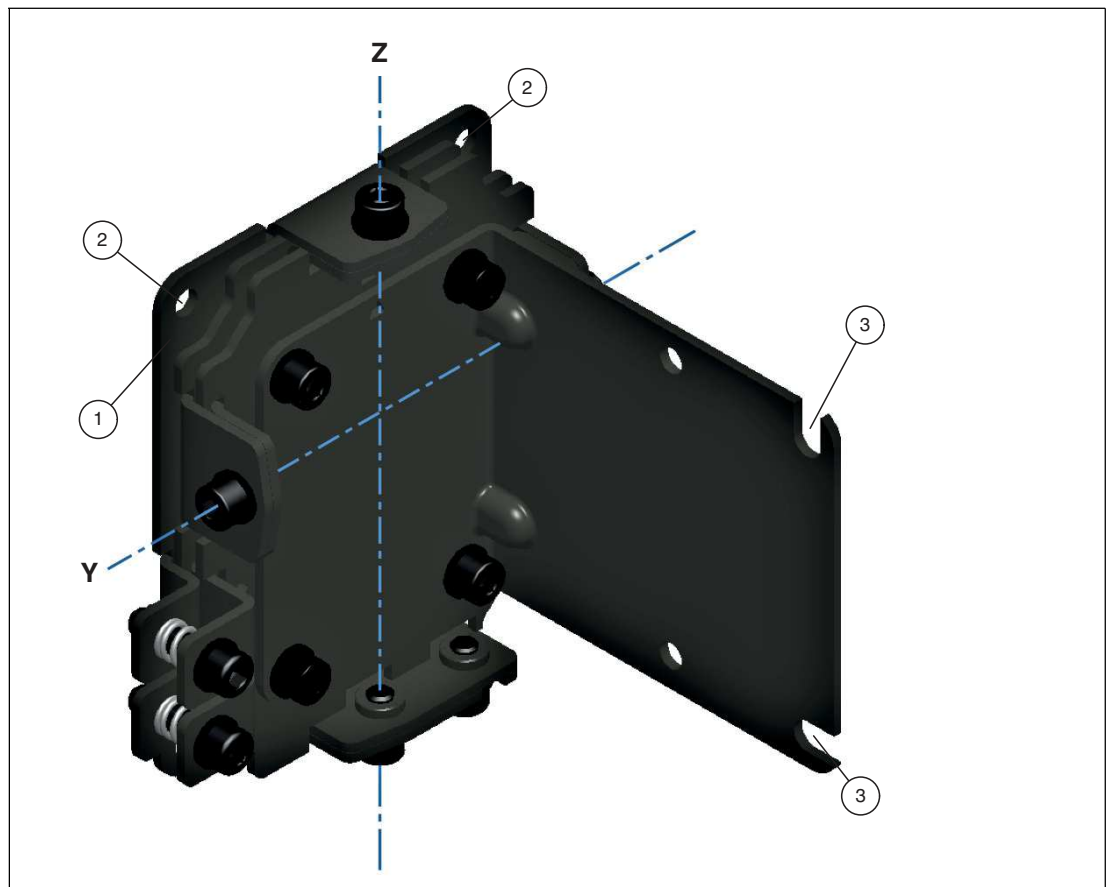

Figure 5.1

- 1 Base plate
- 2 Bore \varnothing 5.3 mm
- 3 Slot

1. Position the fixture in the desired measurement direction.



Note

To precisely adjust the device horizontally or vertically, align the fixture to the optimal vertical position.

2. Position the intersection of the Y-axis and Z-axis at the level of the reflector.
3. To install the fixture, use the holes (2) in the corners of the base plate (1). Secure the fixture with four M5 mounting screws and four flat washers.



Note

Influencing of the Measurement Result

A loose fixture can affect the measurement result.

Check that the fixture is firmly seated.



Mounting the Device on the Fixture

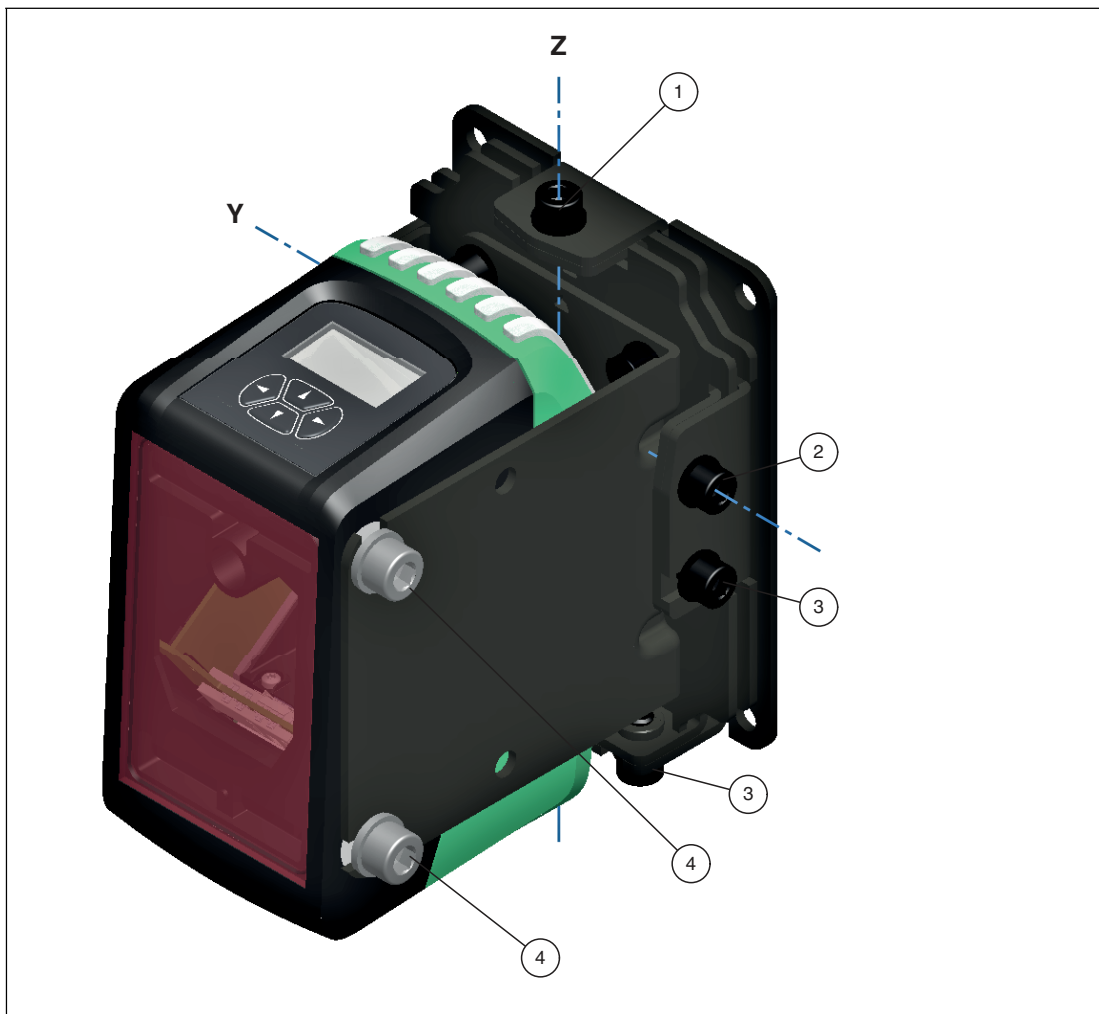

Figure 5.2

- 1 Z-axis locking screw
- 2 Y-axis locking screw
- 3 Locking screw for holding the device in position
- 4 M6 fixing screw with flat washer

1. Remove the device from the packaging.
2. Screw the M6 fixing screws with the flat washers (4) into the M6 tapped side holes so that the clearance between the flat washer and the device wall is approximately 3 mm. The fixing screws are included in the scope of delivery.
3. Hang the device in the slots of the fixture and tighten the M6 fixing screws to secure the device to the fixture.
Ensure a maximum tightening torque of 3.6 Nm when securing the fixing screws.



Note

Before adjusting the device, make sure that all locking screws on the fixture have been loosened.

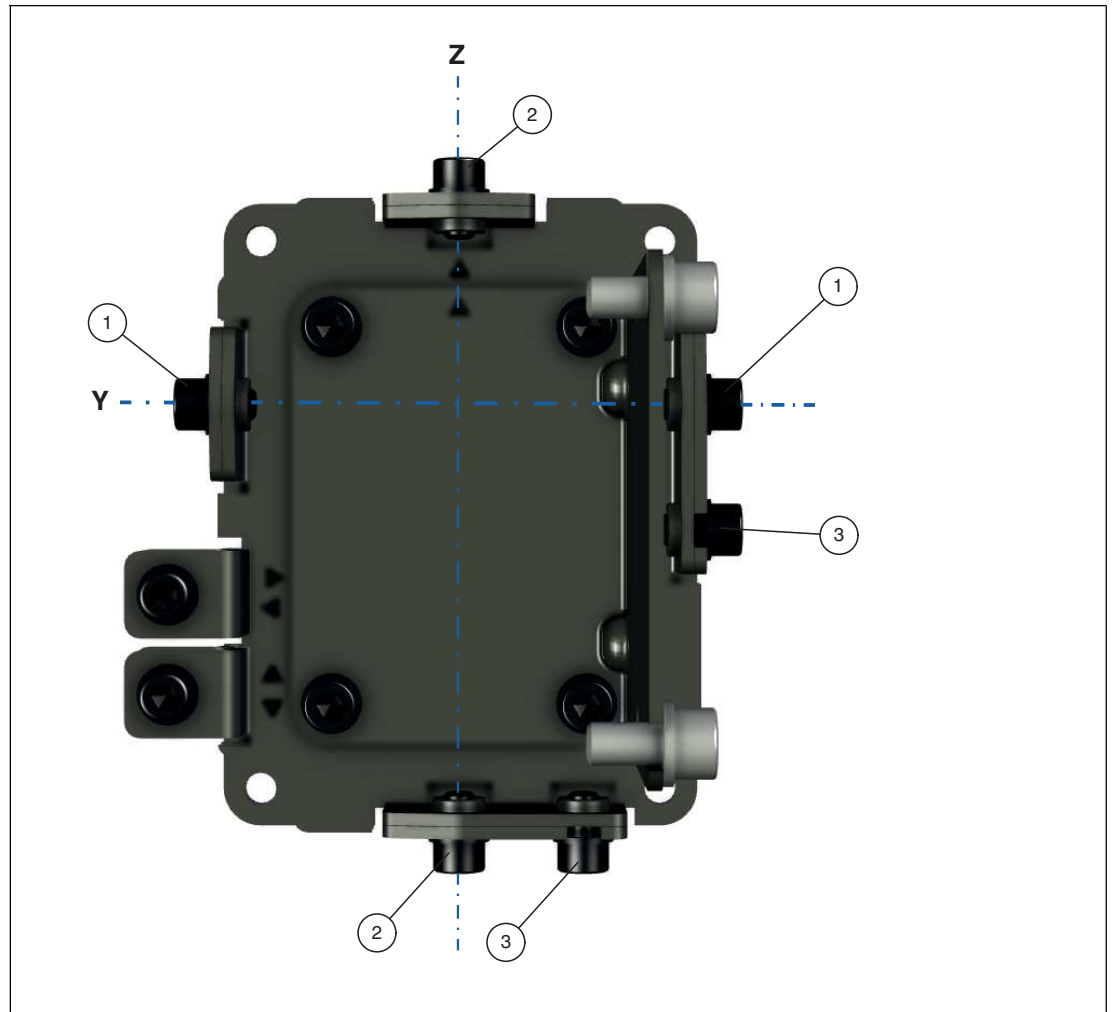

Figure 5.3

- 1 Y-axis locking screw
- 2 Z-axis locking screw
- 3 Locking screw for holding the device in position



Adjusting the Device

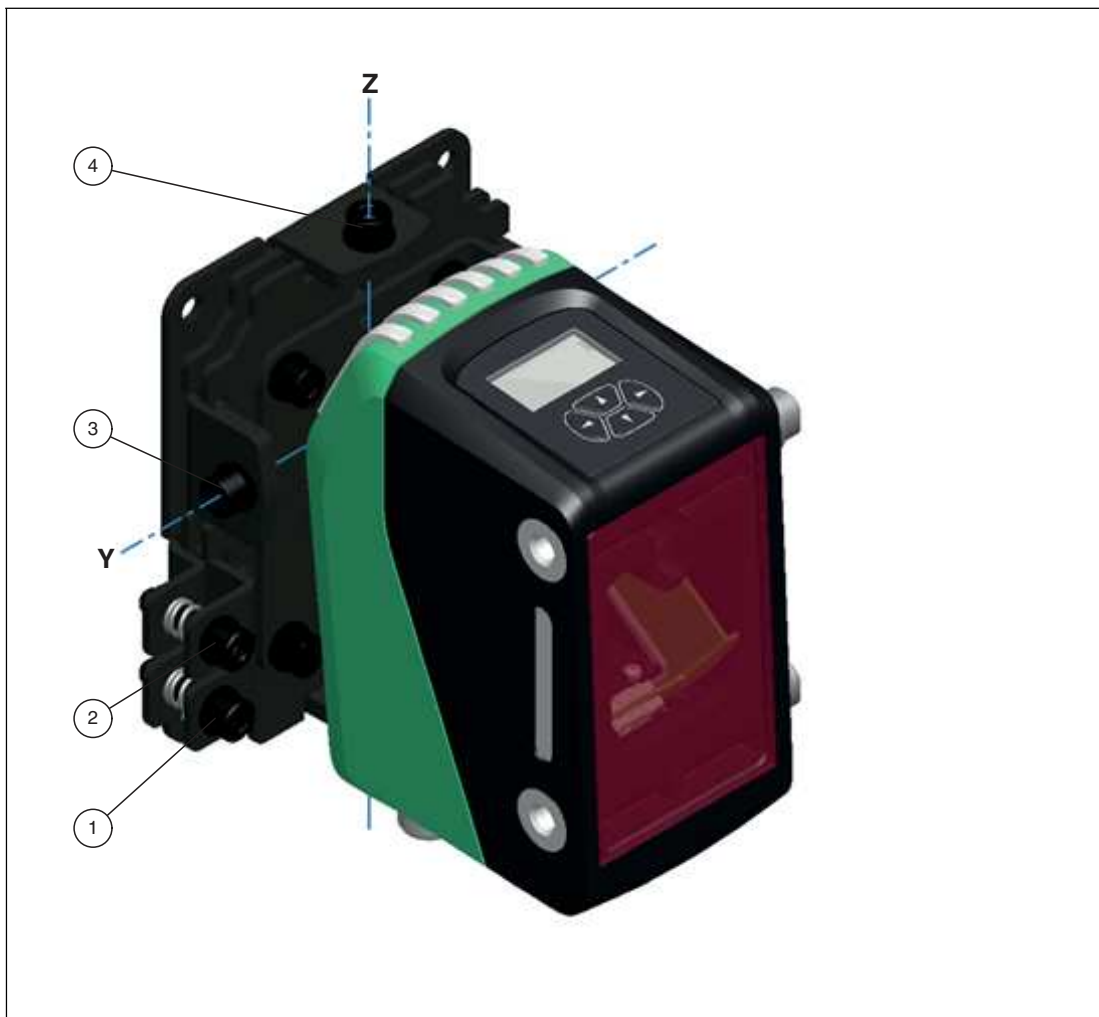

Figure 5.4

- 1 Y-axis adjusting screw
- 2 Z-axis adjusting screw
- 3 Y-axis locking screw
- 4 Z-axis locking screw

1. Switch on the device so that the laser beam is visible on the reflector.
2. First place the reflector at a close distance (e.g., 5 m).



Tip

To make the laser beam easier to see, we recommend that you position the reflector by eye in the vicinity of the device.

3. Align the laser beam as centrally as possible by turning the tilt adjustment screw with an Allen key. First set the Y axis and then the Z axis.

- **Y-axis:**
To move the laser beam to the left on the reflector, turn the adjusting screw (1) clockwise.
To move the laser beam to the right on the reflector, turn the adjusting screw (1) counter-clockwise.
 - **Z-axis:**
To move the laser beam down on the reflector, turn the adjusting screw (2) clockwise.
To move the laser beam up on the reflector, turn the adjusting screw (2) counterclockwise.
4. Gradually increase the distance to the reflector and repeat the last step.
 5. To secure the device in the set position, tighten the locking screws to hold it in place.
 6. To prevent accidental movement of the device during operation, tighten the two M5 locking screws (3) on the Y-axis and the two M5 locking screws (4) on the Z-axis.
Ensure a maximum tightening torque of 4.4 Nm when securing the fixing screws.

5.4 Reflector Selection

	Reflector 250 mm x 250 mm	Reflector 500 mm x 500 mm	Reflector 1000 mm x 1000 mm
OMR50M-R1000	Yes	Yes	Yes
OMR150M-R1000	No	Yes	Yes

Table 5.1 Reflector Selection

5.5 Reflector Arrangement

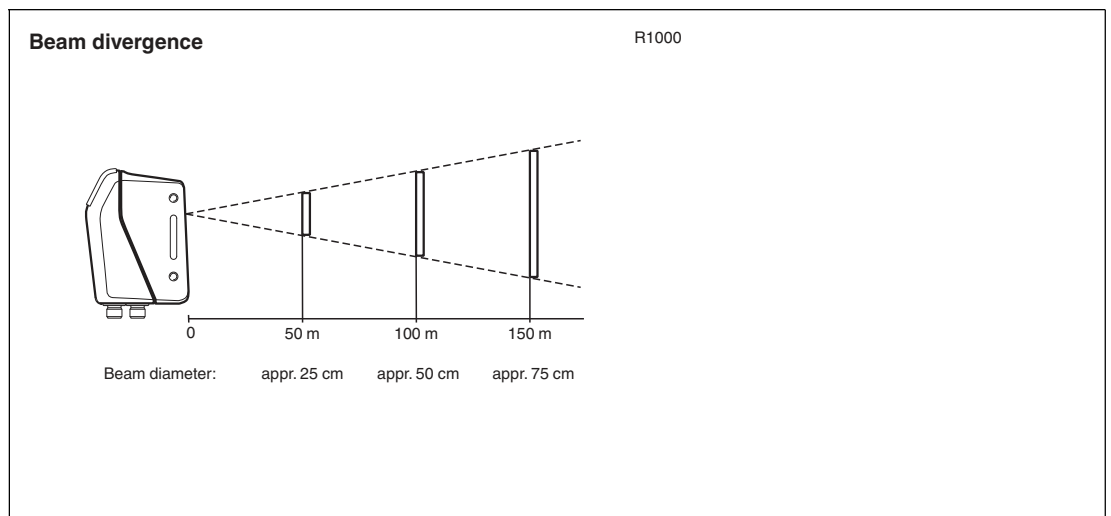

Figure 5.5 Reflector size

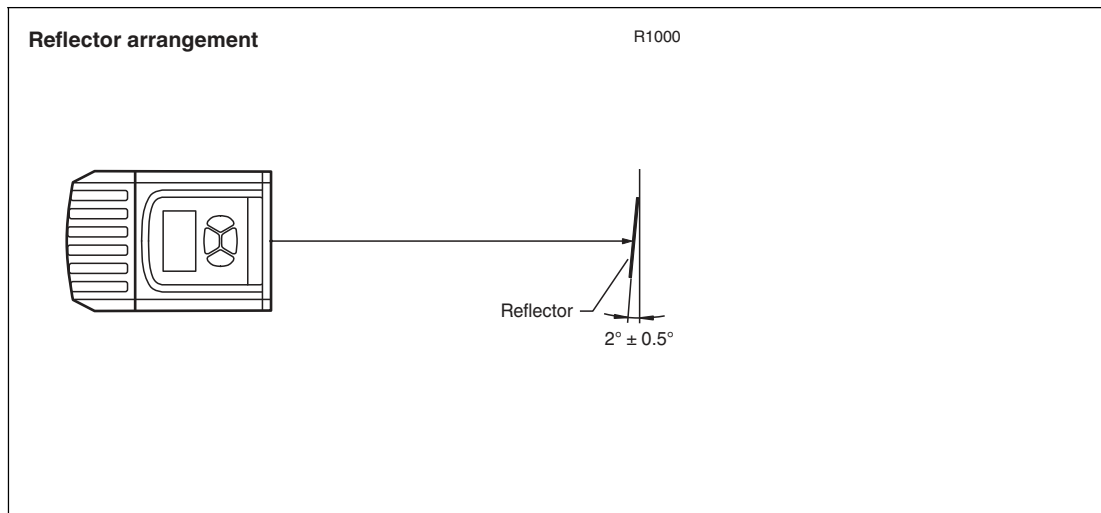

Figure 5.6 Mounting of the reflector

5.6 Device Connection

SSI



Note

Terminator

If there is no terminator connected on the interface card, you must connect a 100 Ω terminator (0.25 W) between Data+ and Data- on the control computer. A double-sided screen mounting is recommended.

5.7 Grounding/Shielding

The grounding can be mounted using the thread on the bottom of the device. The mounting threads are at the same potential as the thread on the bottom of the housing.

Accessories for connecting the grounding are included in the scope of delivery.

- 6.3 mm cable lug
- Cable eye for connecting loose cable (can be used as an alternative to a cable lug)
- M4 mounting screw with hexagon socket, 10 mm thread length
- Lock washer

The device has mounting holes on the side and an M4 hole on the underside. The functional ground can be connected to the M4 hole.

These holes are connected to an internal metal frame and the "0 V" connection pin via overvoltage protection elements.

If interfaces are used that require shielding (e.g., SSI), place the shield on both sides and connect the functional ground to the PE. The shielding of the interface connection has an internal electrical connection to the metal frame and therefore to the functional ground.



Note

The overvoltage protection elements limit the maximum voltage between "0 V" and functional ground to 50 V. A 500 V insulation test cannot therefore be performed.

5.8 Notes for Parallel Operation of R1000 Series Devices and Optical Data Couplers

If R1000 series devices and optical data couplers are operated in parallel, observe the following:

Arranging the devices

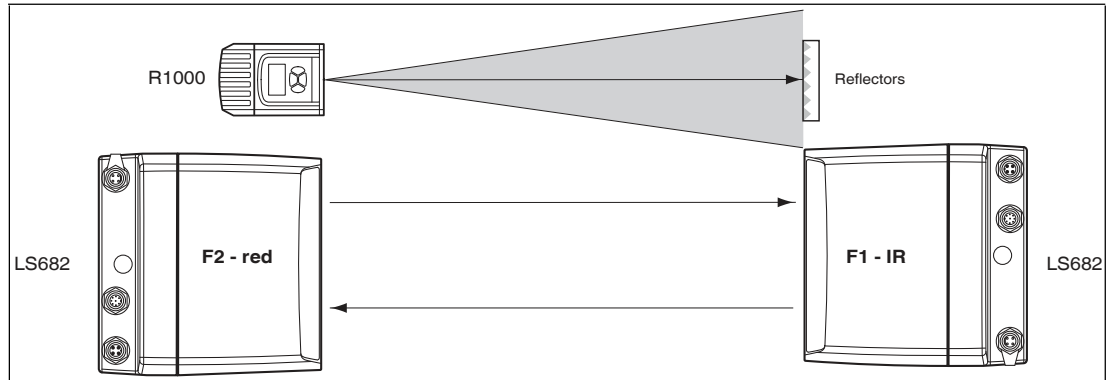

Figure 5.7

When commissioning, make sure that the optical data couplers are correctly aligned with each other first before the R1000 is put into operation.

6 Commissioning



Commissioning the Device

1. Connect the distance measurement device to the power supply.
 - ↳ The device starts an initialization phase for a maximum of 5 seconds.
2. If the device was not aligned correctly, refer to the messages on the display.
3. If the device was aligned correctly with the reflector and valid measurements are obtained, the red error LED (ERR) goes out and the yellow target LED (TGT) lights up.
 - ↳ The device is ready for operation.
 - ↳ The device provides valid measured values.
4. Allow a warm-up phase of 10 minutes for the distance measurement device.
 - ↳ The distance sensor achieves the specified measurement accuracy after 6 minutes.

6.1 Display

6.1.1 Operating Indicator

During normal operation (menu not active), an operating indicator provides information about the state of the device.

In addition to the currently measured distance, the display shows important configurable settings of the device.

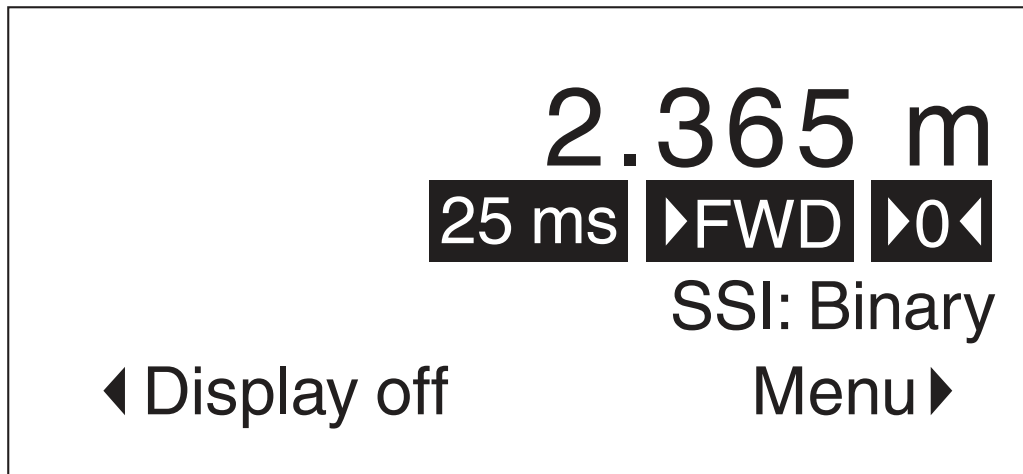

Figure 6.1 Example display

Measurement Delay	Counting Direction		Offset	Communication Interface		
25 ms	►FWD	Forward	►0◀	No offset	<blank>	SSI deactivated
	►REV	Reverse	►+◀	Positive offset	SSI: Binary	SSI with binary coding
			►-◀	Negative offset	SSI: Gray	SSI with gray coding

Table 6.1 Description of the display contents
bold = example

2022-03

6.1.2 Display Timeout

The display switches off after a configurable time.



Activating the Display

1. To activate the display, press any key.



Deactivating the Display

1. To explicitly deactivate the display, press the  key.

7 Settings

7.1 Operation

The device offers a wide range of configuration options organized in a hierarchical menu structure.

Four membrane keys are located below the display. You can use these four keys to navigate within the menu structure and change the settings.

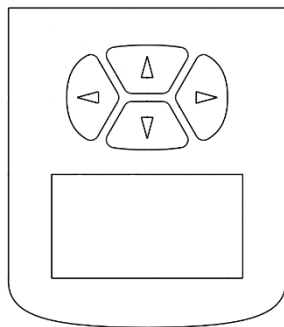

Figure 7.1 Display and arrow keys

Meaning of Keys





	Call the main menu Call submenus Confirm changes / input values
	Return to the operating display Exit submenus Discard changes / input values Deactivate the display
	Navigate up in the menu tree Change values
	Navigate down in the menu tree Change values

Table 7.1

When you enter numerical values, the device constantly verifies that the value entered is valid. A corresponding message is issued if unacceptable values are entered. Invalid values cannot be saved.

Once all the settings have been made, you can use the  key to return to the operating indicator. If no further keys are pressed within the menu levels for 10 minutes, the display automatically returns to the operating indicator.

You can choose to display the menu in German or English.

7.2 Menu Structure

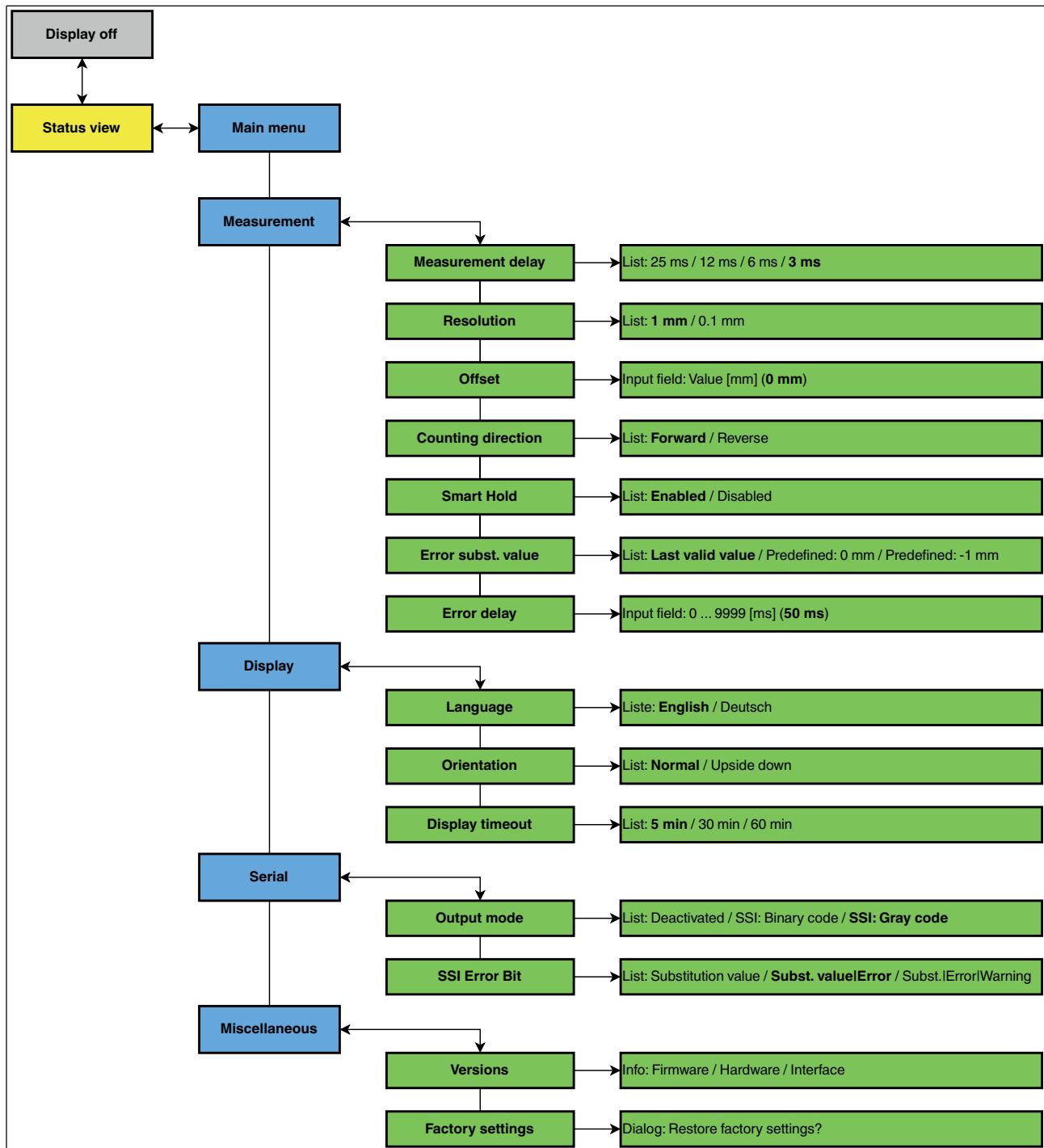

Figure 7.2 Menu Structure in German

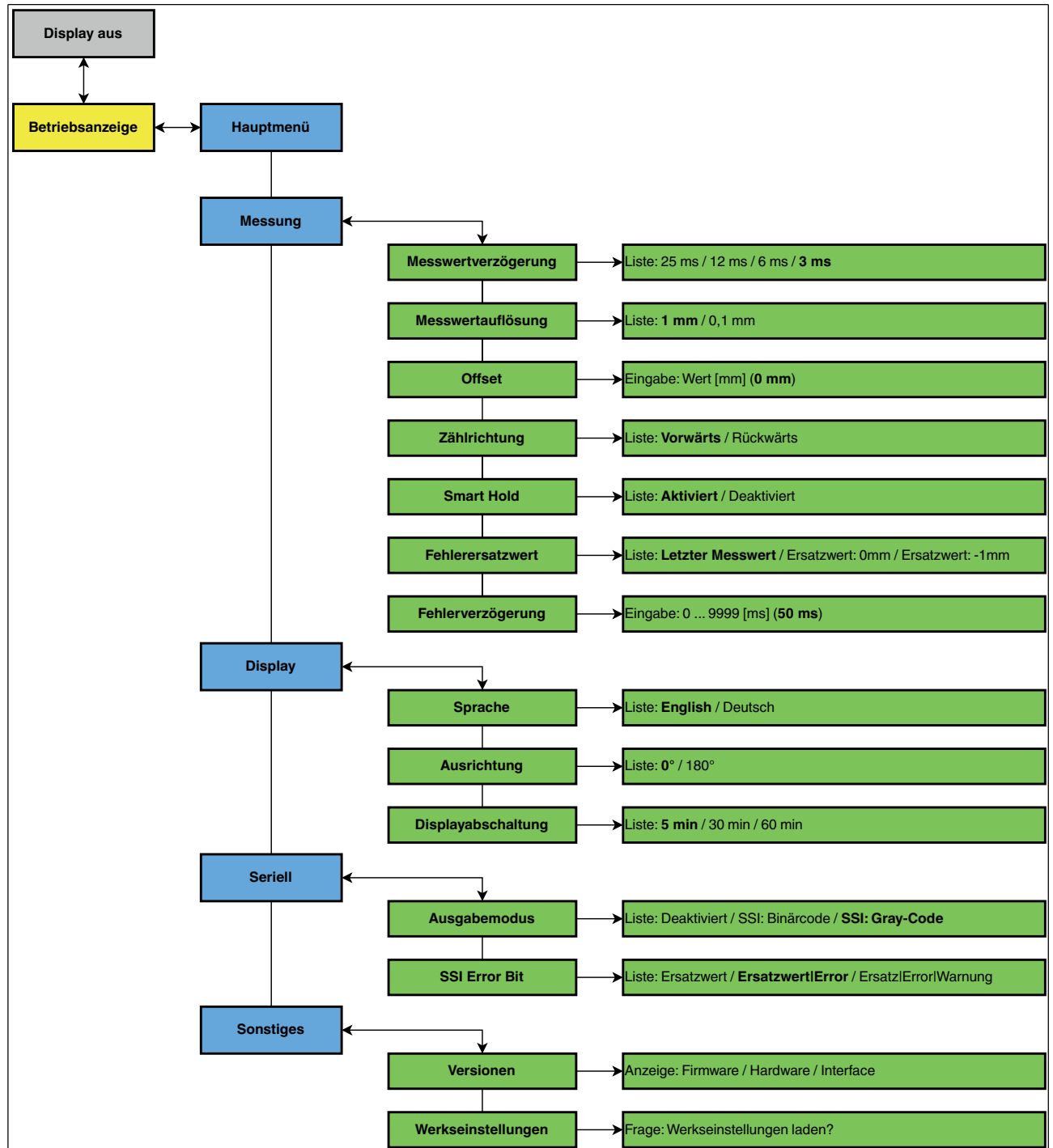

Figure 7.3 Menu Structure in English

7.3 Description of Menu Items

7.3.1 Measurement Menu Item

The "Measurement "submenu contains various parameters that have an impact on recording and issuing the distance measured value.

Measurement Delay

This setting is used to determine the measurement delay for the measured values output by the sensor. The measurement delay can be set to 25 ms, 12 ms, 6 ms, or 3 ms. A higher measurement delay reduces the measurement noise; a smaller measurement delay improves the response time. The factory default setting is 3 ms.

Measured Value Resolution

This parameter defines the resolution of the distance value output on the display and in the process data. The settings "1 mm/bit" and "0.1 mm/bit" are available for selection. The factory default setting is "1 mm/bit."

Offset

This value moves the zero point of the measurement. This enables multiple devices with different positions to be set to identical distances. It does not change the absolute range. The measured value output is calculated from the sum of the absolute measured value and the signed offset. The resulting measured value is used when testing the distance limits. The factory default setting is 0 m.

Note

If the resulting measured value is negative, an error is displayed by the device.

- If this is the case, increase the offset.

Counting Direction

The counting direction setting can be used to invert the measurement's counting direction. The device displays 0 mm at maximum distance. As the distances become smaller, the output value increases. The measured value that is output is calculated from the difference between the limit range and the real measured value. The factory default setting is "forward."

Smart Hold

The smart hold function reduces the noise of the distance value that is output at a standstill. The measurement remains active. Changes to the distance value are output only if they exceed an internal threshold value. The factory default setting is "active."

Error Substitute Value

This option defines which distance value is output by the device in the event of an error. You can choose between the substitute value 0 mm, the substitute value -1 mm, and the last valid measured value. The substitute value -1 mm is displayed as 999.999 m. If the device is unable to determine a valid measured value when using the "last measured value" setting, the value 999.999 m is output. The factory default setting is "last measured value."

Error Delay

This setting defines a time delay for outputting an error. The delay occurs between the occurrence of an error and the signaling of the error using the error flag and signal display. The error delay is specified in milliseconds. The factory default setting is "50 ms."

7.3.2

Menu Item Display

Display Language

You use this menu item to select the menu language. The available settings are German and English. The factory default setting is "English."

Display Orientation

You use this menu item to change the orientation of the display. The setting options are 0° and 180° for overhead mounting. In this case, the function of the keys is rotated by 180°. The factory default setting is "0°."

2022-03

Display Timeout

You use this menu item to set the time after which the display is automatically deactivated. Possible values are 5 min, 30 min, and 60 min.

The factory default setting is "5 min."

7.3.3 Serial Menu Item

Output Mode

You use this menu item to configure the serial interface. The modes that can be set are "SSI: Binary Code" and "SSI: Gray Code." The factory default setting is "SSI: Gray Code."

SSI Error Bit

You use this menu item to configure the behavior of the SSI error bit (see chapter 9.1.2). The SSI error bit can optionally be set,

- if an error substitute value is present,
- if an error substitute value is present or an error occurs, or
- if a substitute error value is present or an error or warning occurs.

The menu entry is visible only if the output mode is set to "SSI: Binary Code" or "SSI: Gray Code."

7.3.4 Miscellaneous Menu Item

Versions

You can use this menu item to check the hardware version, firmware version, and interface version.

Factory Settings

You can use this menu item to reset all of the device's settings to the factory default settings. A security prompt is displayed to protect against accidental resets.

8 Troubleshooting

8.1 Error Message

The device is capable of issuing a number of error messages. Error messages indicate that the device is not working optimally.

Measured value determination and measured value output may be affected depending on the error.

Error LED	Power LED	Error message on the display	Cause	Fault repair
On	Off	Device faulty	A defect that cannot be resolved by the user has been detected.	<ul style="list-style-type: none"> Contact the service center.
On	On	No reflector detected	Reflector is not detected.	<ul style="list-style-type: none"> Check the alignment of the device. If necessary, clean the lens.
On	On	Measured value above measuring range	Reflector is located too far from the device.	<ul style="list-style-type: none"> Position the reflector within the measuring range. More information can be found in the datasheet.
On	On	Measured value below measuring range	Reflector is too close to the device.	<ul style="list-style-type: none"> Position the reflector within the measuring range. More information can be found in the datasheet.
On	On	Negative measured value	The sum of the absolute measured value and the user-defined offset is negative.	<ul style="list-style-type: none"> Correct the offset.
On	On	Invalid measured values	The device does not determine any valid measured values.	<ul style="list-style-type: none"> Check the device for dirt and clean the optical interface if necessary.
On	On	Device temperature too low	Ambient temperature too low.	<ul style="list-style-type: none"> Use the device only within the permitted temperature range; if necessary, wait for the temperature to rise. More information can be found in the datasheet.
On	On	Device temperature too high	Ambient temperature too high.	<ul style="list-style-type: none"> Use the device only within the permitted temperature range. Check whether it is in direct sunlight. More information can be found in the datasheet.

Table 8.1

8.2 Warning Message

The device can issue various warning messages. Warning messages indicate that the device may be approaching an error state. Measured value determination and measured value output are not affected at any time.

Error LED	Power LED	Error Message on the Display	Cause	Fault Repair
Flashing	On	Device temperature too low	Ambient temperature is too low.	<ul style="list-style-type: none"> Use the device only within the permitted temperature range; if necessary, wait for the temperature to rise. More information can be found in the datasheet.
Flashing	On	Device temperature too high	Ambient temperature too high.	<ul style="list-style-type: none"> Use the device only within the permitted temperature range. Check whether it is in direct sunlight. More information can be found in the datasheet.
Off	On	Parameter access failed	Operation could not be completed successfully.	<ul style="list-style-type: none"> Repeat the operation that was initiated.

Table 8.2

Your automation, our passion.

Explosion Protection

- Intrinsic Safety Barriers
- Signal Conditioners
- FieldConnex® Fieldbus
- Remote I/O Systems
- Electrical Ex Equipment
- Purge and Pressurization
- Industrial HMI
- Mobile Computing and Communications
- HART Interface Solutions
- Surge Protection
- Wireless Solutions
- Level Measurement

Industrial Sensors

- Proximity Sensors
- Photoelectric Sensors
- Industrial Vision
- Ultrasonic Sensors
- Rotary Encoders
- Positioning Systems
- Inclination and Acceleration Sensors
- Fieldbus Modules
- AS-Interface
- Identification Systems
- Displays and Signal Processing
- Connectivity

Pepperl+Fuchs Quality

Download our latest policy here:

www.pepperl-fuchs.com/quality

