

LCR10

Level Radar

Brief Instructions

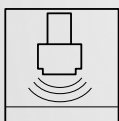

Your automation, our passion.

 **PEPPERL+FUCHS**

With regard to the supply of products, the current issue of the following document is applicable:
The General Terms of Delivery for Products and Services of the Electrical Industry, published by the Central Association of the Electrical Industry (Zentralverband Elektrotechnik und Elektroindustrie (ZVEI) e.V.) in its most recent version as well as the supplementary clause: "Expanded reservation of proprietorship"

Worldwide

Pepperl+Fuchs Group

Lilienthalstr. 200

68307 Mannheim

Germany

Phone: +49 621 776 - 0

E-mail: info@de.pepperl-fuchs.com

North American Headquarters

Pepperl+Fuchs Inc.

1600 Enterprise Parkway

Twinsburg, Ohio 44087

USA

Phone: +1 330 425-3555

E-mail: sales@us.pepperl-fuchs.com

Asia Headquarters

Pepperl+Fuchs Pte. Ltd.

P+F Building

18 Ayer Rajah Crescent

Singapore 139942

Phone: +65 6779-9091

E-mail: sales@sg.pepperl-fuchs.com

<https://www.pepperl-fuchs.com>

1	Introduction	5
1.1	Content of this Document	5
1.2	Safety Information	6
1.3	Symbols Used	6
2	Documentation	8
2.1	Technical Information (TI)	8
2.2	Manual (BA)	8
2.3	Brief Instructions (KA)	8
2.4	Instruction Manual (SI)	8
3	Terms and Abbreviations	9
3.1	Document Types	9
3.2	Abbreviations	9
4	Registered Trademarks	10
5	Basic Safety Instructions	11
5.1	Requirements for Personnel	11
5.2	Designated Use	11
5.3	Workplace safety	12
5.4	Operational safety	12
5.5	Product Safety	13
6	Product Description	14
6.1	Product Design	14
7	Incoming Acceptance and Product Identification	15
7.1	Goods Acceptance	15
7.2	Product Identification	15
7.3	Manufacturer Address	15
7.4	Nameplate	16
8	Installation	17
8.1	Installation Conditions	17
8.2	Post-installation Check	25

9	Electrical Connection	26
9.1	Cable Assignment	26
9.2	Supply Voltage	26
9.3	Connecting the Device	27
9.4	Post-connection Check	27
10	Operability	28
10.1	Operating Concept	28
10.2	Operation via Bluetooth® Wireless Technology	28
11	Commissioning and Operation	29
11.1	Commissioning via P+F Level (App)	29
12	Diagnostics and Troubleshooting	31
12.1	General Errors	31
12.2	Error – P+F Level Operation	32
12.3	Diagnostic Event in the Operating Tool	33

1 Introduction

1.1 Content of this Document

This document contains information that you need in order to use your product throughout the applicable stages of the product life cycle. These can include the following:

- Product identification
- Delivery, transport, and storage
- Mounting and installation
- Commissioning and operation
- Maintenance and repair
- Troubleshooting
- Dismounting
- Disposal



Note

This document does not substitute the instruction manual.



Note

For full information on the product, refer to the instruction manual and further documentation on the Internet at www.pepperl-fuchs.com.

The documentation consists of the following parts:

- Datasheet – product overview
The datasheet contains the essential technical data for product selection.
- Technical information (TI) – planning aid
The document contains all the technical data on the device and provides an overview of the accessories and other products that can be ordered for the device.
- Manual (BA) – complete information
The manual contains all information from incoming acceptance to disposal.
- Brief instructions (KA), present document – guide that takes you quickly to the 1st measured value
The brief instructions contain all the essential information from incoming acceptance to initial commissioning.
- Instruction manual (SI) – safety-relevant document
Depending on the approval, the required instruction manuals are supplied with the device.

Additionally, the following parts may belong to the documentation, if applicable:

- EU-type examination certificate
- EU declaration of conformity
- Attestation of conformity
- Certificates
- Control drawings
- Additional documents

1.2 Safety Information

Target Group, Personnel

Responsibility for planning, assembly, commissioning, operation, maintenance, and dismantling lies with the plant operator.

Only appropriately trained and qualified personnel may carry out mounting, installation, commissioning, operation, maintenance, and dismantling of the product. The personnel must have read and understood the instruction manual and the further documentation.

Prior to using the product make yourself familiar with it. Read the document carefully.

1.3 Symbols Used

This document contains symbols for the identification of warning messages and of informative messages.

Warning Messages

You will find warning messages, whenever dangers may arise from your actions. It is mandatory that you observe these warning messages for your personal safety and in order to avoid property damage.

Depending on the risk level, the warning messages are displayed in descending order as follows:



Danger!

This symbol indicates an imminent danger.

Non-observance will result in personal injury or death.



Warning!

This symbol indicates a possible fault or danger.

Non-observance may cause personal injury or serious property damage.



Caution!

This symbol indicates a possible fault.

Non-observance could interrupt the device and any connected systems and plants, or result in their complete failure.

Informative Symbols



Note

This symbol brings important information to your attention.



Action

This symbol indicates a paragraph with instructions. You are prompted to perform an action or a sequence of actions.

Symbols for Certain Types of Information and Graphics



Permitted

Procedures, processes or actions that are permitted.



Forbidden

Procedures, processes or actions that are forbidden.

1, 2, 3 ... Item numbers

A, B, C, ... Views

2 Documentation

The following document types are available on the Pepperl+Fuchs website:
www.pepperl-fuchs.com → search → model number → product detail page → documents.

2.1 Technical Information (TI)

Planning aid

The document contains all the technical data on the device and provides an overview of the accessories and other products that can be ordered for the device.

2.2 Manual (BA)

Your reference guide

This document contains all the information that is required in various phases of the life cycle of the device: from product identification, incoming acceptance and storage, to mounting, connection, operation and commissioning through to troubleshooting, maintenance and disposal.

2.3 Brief Instructions (KA)

Guide that takes you quickly to the 1st measured value

This document contains all the essential information from incoming acceptance to initial commissioning.

2.4 Instruction Manual (SI)

Depending on the approval, the following instruction manuals (SI) are supplied with the device. These documents are an integral part of the manual.



Note

The nameplate indicates the instruction manual (SI) that are relevant to the device.

3 Terms and Abbreviations

3.1 Document Types

BA

Document type Manual

KA

Document type Brief Instructions

TI

Document type Technical Information

SI

Document type Instruction manual

3.2 Abbreviations

PN

Nominal pressure

MWP

MWP (**M**aximum **w**orking pressure/max. process pressure)

The MWP can also be found on the nameplate.

ToF

Time of Flight

ϵ_r

DK value – relative dielectric constant

Operating tool

The term **operating tool** is used in place of the following operating software:
P+F Level (app), for operation using an Android or iOS smartphone or tablet

BD

Blocking **D**istance; no signals are analyzed within the BD.

PLC

Programmable logic controller (PLC)

4 Registered Trademarks

Apple®

Apple, the Apple logo, iPhone, and iPod touch are trademarks of Apple Inc., registered in the U.S. and other countries. App Store is a service mark of Apple Inc.

Android®

Android, Google Play and the Google Play logo are trademarks of Google Inc.

Bluetooth®

The *Bluetooth*® word mark and logos are registered trademarks owned by the Bluetooth SIG, Inc. and any use of such marks by Pepperl+Fuchs is under license. Other trademarks and trade names are those of their respective owners.

5 Basic Safety Instructions

5.1 Requirements for Personnel

The personnel for installation, commissioning, diagnostics and maintenance must fulfill the following requirements:

- Trained, qualified specialists must have a relevant qualification for this specific function and task.
- Personnel must be authorized by the plant owner/operator.
- Be familiar with federal/national regulations.
- Before starting work: personnel must read and understand the instructions in the manual and supplementary documentation as well as the certificates (depending on the application).
- Personnel must follow instructions and comply with general policies.

The operating personnel must fulfill the following requirements:

- Personnel are instructed and authorized according to the requirements of the task by the facility's owner-operator.
- Personnel follow the instructions in this manual.

5.2 Designated Use

Application and media

The measuring device described in this manual is intended for continuous, non-contact level measurement in liquids. Because of its operating frequency of approx. 26 GHz, a maximum radiated pulsed power of 5.7 mW and an average power output of 0.015 mW, use outside of closed, metallic vessels is also permitted. If operated outside of closed vessels, the device must be mounted in accordance with the instructions in the **Installation** section. Operation of the devices does not pose a risk to health or the environment.

If the limit values specified in the **Technical data** and the conditions listed in the instructions and additional documentation are observed, the measuring device may be used for the following measurements only:

- Measured process variables: distance
- Calculated process variables: volume or mass in vessels of any shape; flow through measuring weirs or channels (calculated from the level by the linearization functionality)

To ensure that the measuring device remains in proper condition for the operation time:

- Use the measuring device only for media to which the process-wetted materials have an adequate level of resistance.
- Observe the limit values (see **Technical data**).

Incorrect use

The manufacturer is not liable for damage caused by improper or non-designated use.

Verification for borderline cases:

- With regard to special media and media used for cleaning, please contact the manufacturer. Pepperl+Fuchs will be happy to assist in clarifying the corrosion-resistant properties of wetted materials but does not accept any warranty or liability.

Residual risks

Due to heat transfer from the process as well as power dissipation within the electronics, the temperature of the electronics housing and the assemblies contained therein may rise to 80 °C (176 °F) during operation. When in operation, the sensor can reach a temperature close to the medium temperature.

Danger of burns from contact with surfaces!

- In the event of elevated fluid temperatures, ensure protection against contact to prevent burns.

5.3 Workplace Safety

For work on and with the device:

- Wear the required personal protective equipment according to federal/national regulations.

5.4 Operational Safety

Risk of injury!

- Operate the device only if it is in proper technical condition, free from errors and faults.
- The operator is responsible for interference-free operation of the device.

Modifications to the device

Unauthorized modifications to the device are not permitted and can lead to unforeseeable dangers:

- If modifications are nevertheless required, consult with the manufacturer.

Repair

To ensure continued operational safety and reliability:

- Carry out repairs on the device only if they are expressly permitted.
- Observe federal/national regulations pertaining to the repair of an electrical device.
- Use only original spare parts and accessories from the manufacturer.

Hazardous area

To eliminate the risk of danger to persons or the facility when the device is used in the approval-related area (e. g. explosion protection, pressure equipment safety):

- Check the nameplate to verify if the device ordered can be put to its intended use in the approval-related area.
- Observe the specifications in the separate supplementary documentation that is an integral part of this manual.

5.5 Product Safety

This measuring device is designed in accordance with good engineering practice to meet state-of-the-art safety requirements, has been tested, and left the factory in a condition in which it is safe to operate. It meets general safety standards and legal requirements.

5.5.1 CE mark

The measuring system meets the legal requirements of the applicable EU Directives. These are listed in the corresponding EU Declaration of Conformity along with the standards applied.

Pepperl+Fuchs confirms successful testing of the device by affixing to it the CE mark.

6 Product Description

6.1 Product Design

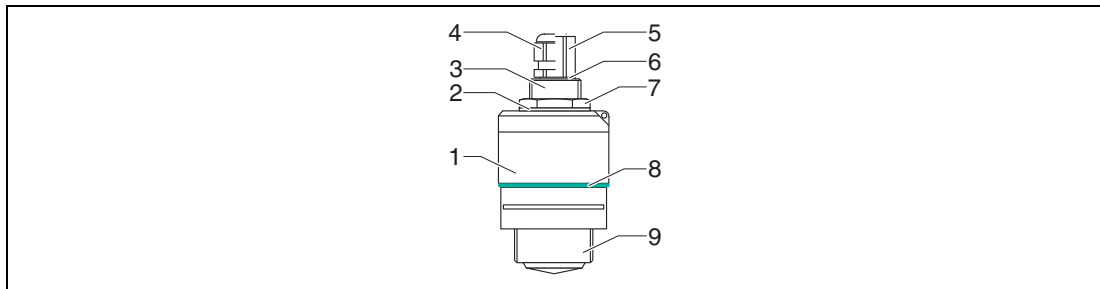

Figure 6.1 Device design

- 1 Sensor housing
- 2 Seal
- 3 Process connection rear side
- 4 Cable gland
- 5 Pipe adapter
- 6 O-ring
- 7 Counter nut
- 8 Design ring
- 9 Process connection front side

7 Incoming Acceptance and Product Identification

7.1 Goods Acceptance

Check the following during goods acceptance:

- Are the order codes on the delivery note and the product sticker identical?
- Are the goods undamaged?
- Do the nameplate data match the ordering information on the delivery note?
- If required (see nameplate): Are the instruction manuals (SI) provided?



Note

If one of these conditions is not met, please contact the manufacturer's sales office.

7.2 Product Identification

The following options are available for the identification of the measuring device:

- Nameplate specifications
- Extended order code with breakdown of the device features on the delivery note

7.3 Manufacturer Address

Pepperl+Fuchs Group Lilienthalstraße 200, 68307 Mannheim, Germany
--

Internet: www.pepperl-fuchs.com
--

Address of the manufacturing plant: See nameplate.

7.4 Nameplate

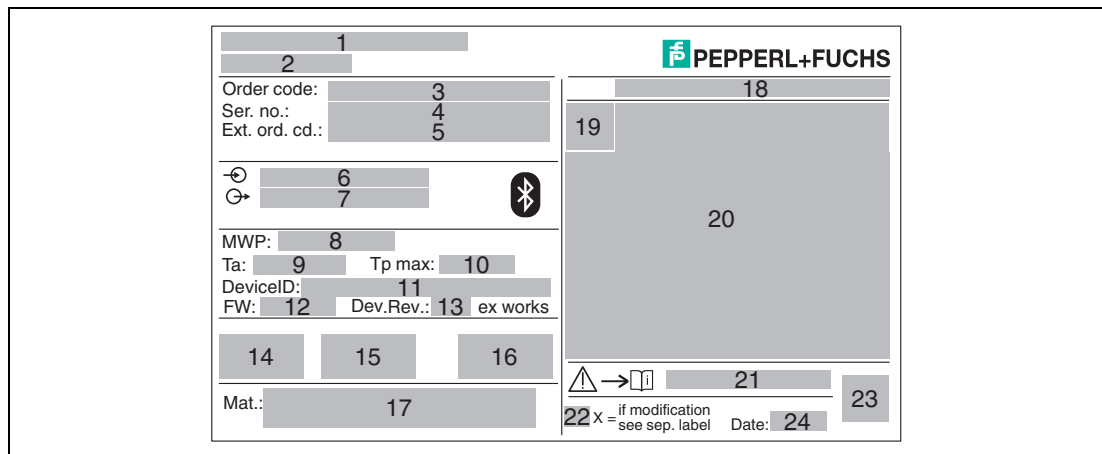

Figure 7.1 Device nameplate

- 1 Manufacturer address
- 2 Device name
- 3 Order code
- 4 Serial number (ser. no.)
- 5 Extended order code (Ext. ord. cd.)
- 6 Supply voltage
- 7 Signal outputs
- 8 Process pressure
- 9 Allowable ambient temperature (T_{amb})
- 10 Maximum process temperature
- 11 Device ID
- 12 Firmware version (FW)
- 13 Device revision (Dev.Rev.)
- 14 CE mark
- 15 Additional information about the device version (certificates, approvals)
- 16 C-tick
- 17 Materials in contact with process
- 18 Degree of protection: e. g. IP, NEMA
- 19 Certificate symbol
- 20 Certificate and approval relevant data
- 21 Document number of the instruction manuals: e. g. SI, ZD, ZE
- 22 Modification mark
- 23 2-D matrix code (QR code)
- 24 Manufacturing date: year-month

Note

Up to 33 characters of the extended order code are indicated on the nameplate. If the extended order code contains additional characters, these cannot be displayed.

However, the complete extended order code can also be displayed via the device operating menu: **Extended order code 1 to 3** parameter.



8 Installation

8.1 Installation Conditions

8.1.1 Installation Types

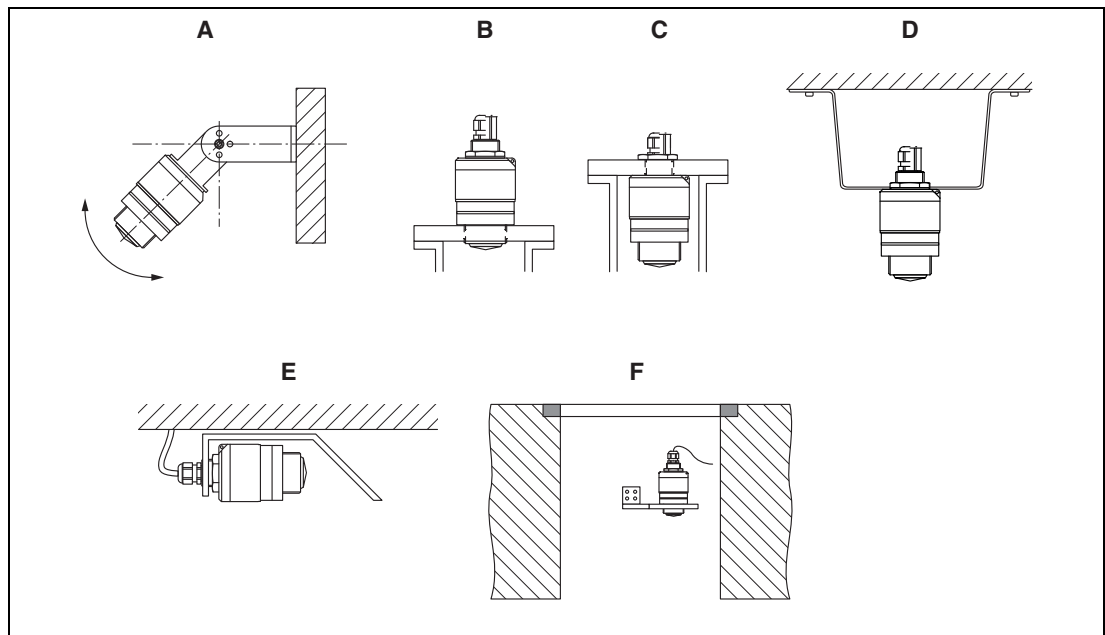

Figure 8.1 Wall, ceiling or nozzle installation

- A** Wall or ceiling mount, adjustable
- B** Mounted at front thread
- C** Mounted at rear thread
- D** Ceiling installation with counter nut (included in delivery)
- E** Horizontal installation in confined spaces (sewer shaft)
- F** Shaft wall mounting



Caution!

The sensor cables are not designed as supporting cables. Do not use them for suspension purposes.

Always operate the device in a vertical position in free-space applications.

8.1.2 Nozzle Installation

The antenna should be located out of the nozzle for optimum measurement.
The interior of the nozzle must be smooth and may not contain any edges or welded joints.
The edge of the nozzle should be rounded if possible.

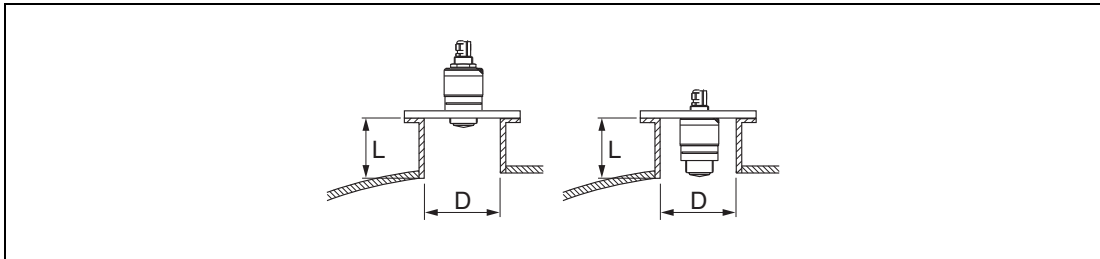

Figure 8.2 Nozzle installation

D Nozzle diameter

L Nozzle length

The maximum length of the nozzle **L** depends on the nozzle diameter **D**. Please note the limits for the diameter and length of the nozzle.

Installation outside nozzle

- D: min. 40 mm (1.5 inch)
- L: max. $D \times 1.5$

Installation inside nozzle

- D: min. 80 mm (3 inch)
- L: max. 140 mm (5.5 inch) + $D \times 1.5$

8.1.3 Position for Installation on a Vessel

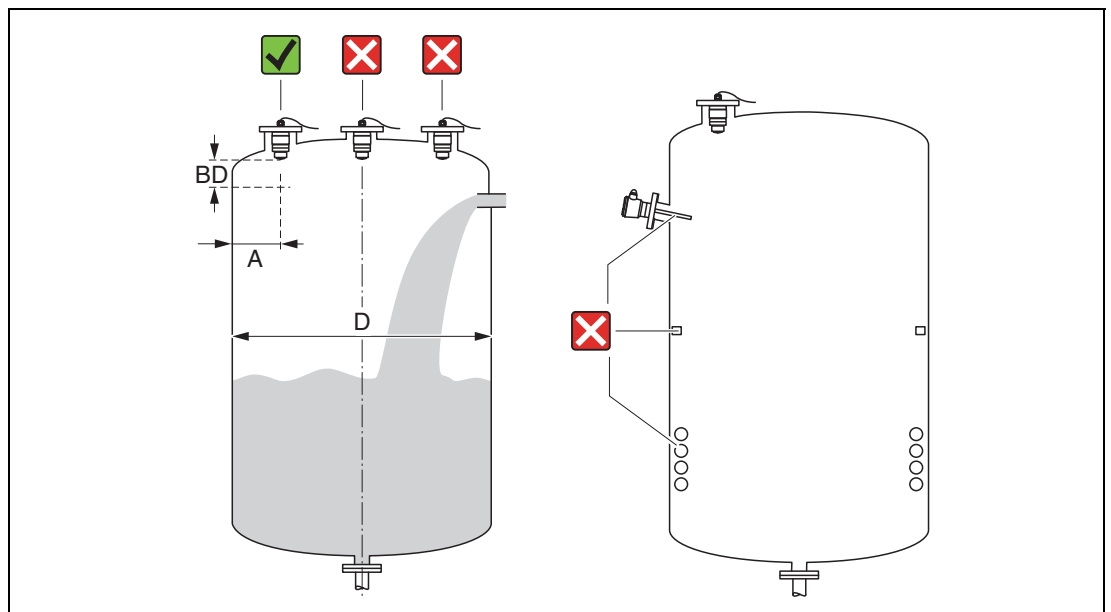

Figure 8.3 Installation position on a vessel

- If possible install the sensor so that its lower edge projects into the vessel.
- Recommended distance **A** wall – nozzle outer edge: ~ 1/6 of the vessel diameter **D**. Under no circumstances should the device be mounted closer than 15 cm (5.91 inch) to the vessel wall.
- Do not install the sensor in the middle of the vessel.
- Avoid measurements through the filling curtain.
- Avoid equipment such as limit switches, temperature sensors, baffles, heating coils etc.
- No signals are evaluated within the Blocking distance (BD). It can therefore be used to suppress interference signals (e. g. the effects of condensate) in the vicinity of the antenna.

An automatic Blocking distance of at least 0.1 m (0.33 foot) is configured as standard. However, this can be overwritten manually (0 m (0 foot) is also permitted).

Automatic calculation:

Blocking distance = Empty calibration – Full calibration – 0.2 m (0.656 foot).

Each time a new entry is made in the **Empty calibration** parameter or **Full calibration** parameter, the **Blocking distance** parameter is recalculated automatically using this formula.

If the result of the calculation is a value < 0.1 m (0.33 foot), the Blocking distance of 0.1 m (0.33 foot) will continue to be used.

8.1.4 Device Alignment for Installation on a Vessel

- Align the antenna vertically to the product surface.
- Align the eyelet with lug towards the vessel wall as well as possible.

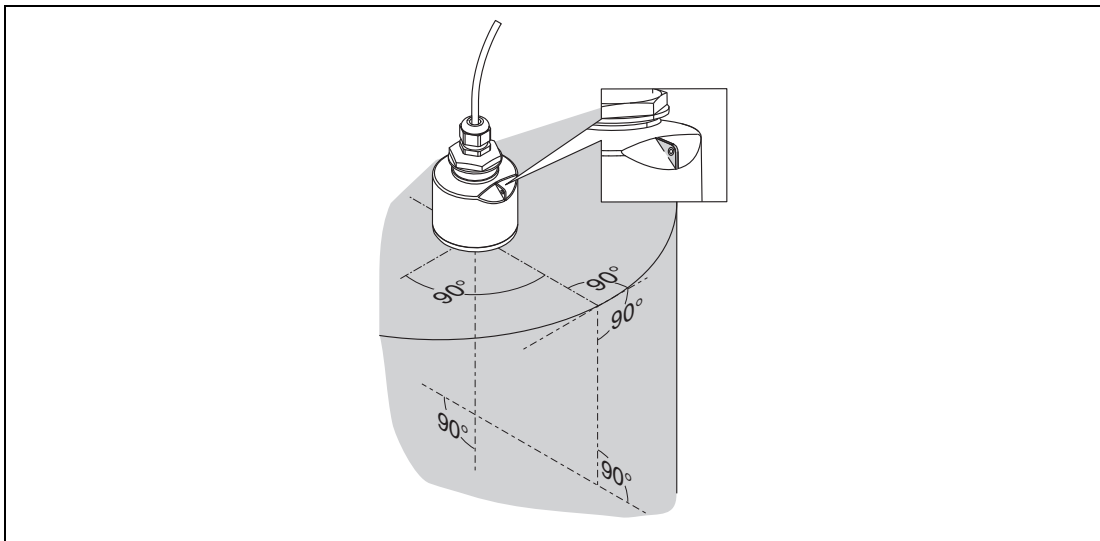

Figure 8.4 Device alignment for installation on a vessel

8.1.5 Beam Angle

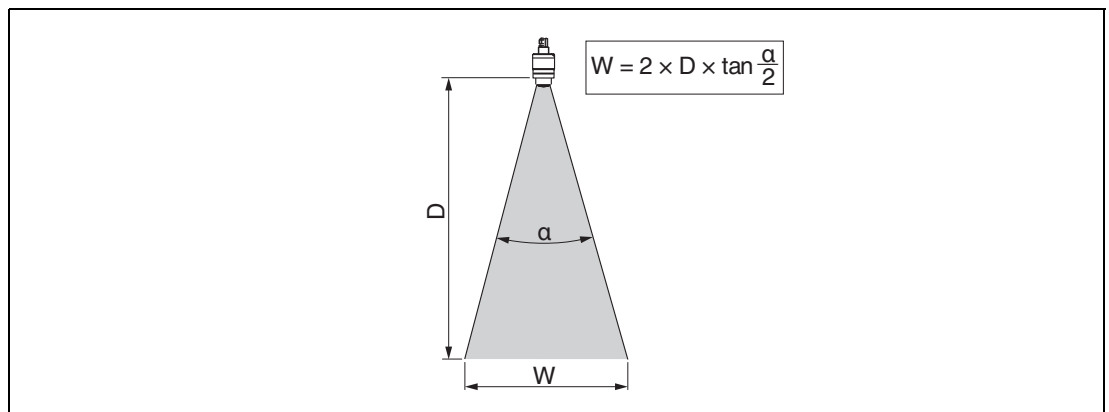

Figure 8.5 Relationship between beam angle α , distance D and beamwidth diameter W

The beam angle is defined as the angle α , at which the power density of the radar waves reaches half the value of the maximum power density (3 dB width). Microwaves are also emitted outside the signal beam and can be reflected off interfering installations.

Beam diameter W as a function of beam angle α and distance D .

40 mm (1.5 inch) antenna, α 30 °

$$W = D \times 0.54$$

40 mm (1.5 inch) antenna with flooding protection tube, α 12 °

$$W = D \times 0.21$$

8.1.6 Measurement in Plastic Vessels

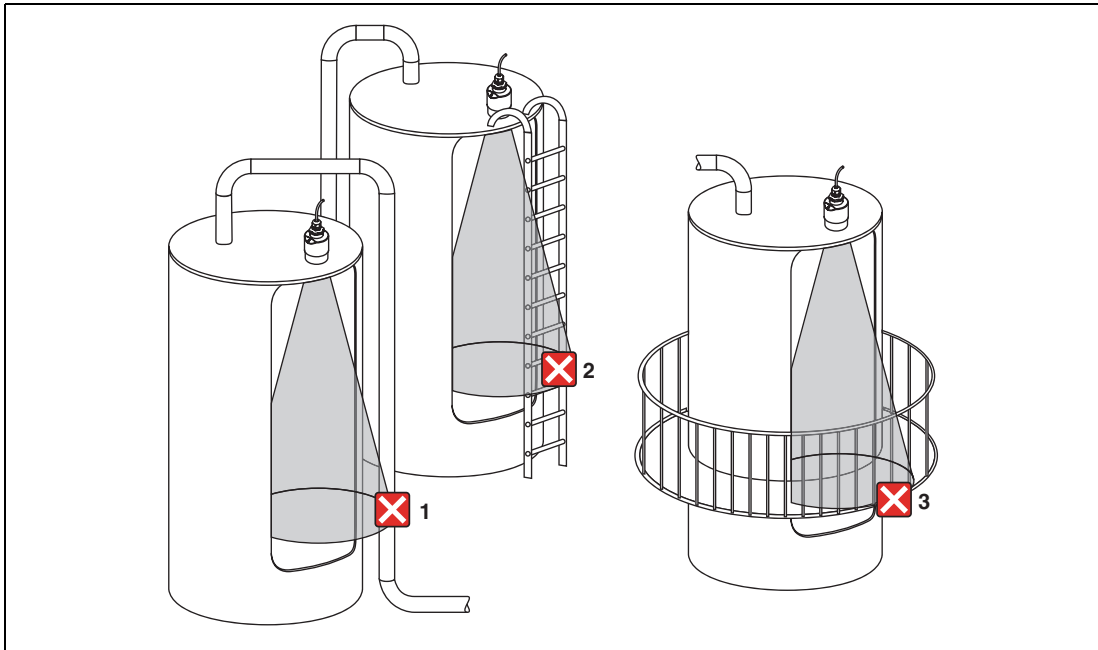

Figure 8.6 Measurement in a plastic vessel with a metallic, interfering installation outside of the vessel

- 1 Pipe, tubing
- 2 Ladder
- 3 Grate, railing

If the outer wall of the vessel is made of a non-conductive material (e. g. GFR), microwaves can also be reflected by interfering installations outside of the vessel.

Please ensure there are no interfering installations made of a conductive material in the signal beam (see the beam angle section for information on calculating the beamwidth diameter).

Please contact the manufacturer for further information.

8.1.7 Weather Protection Cover

For outdoor use, a weather protection cover is recommended.

The weather protection cover is available as an accessory.

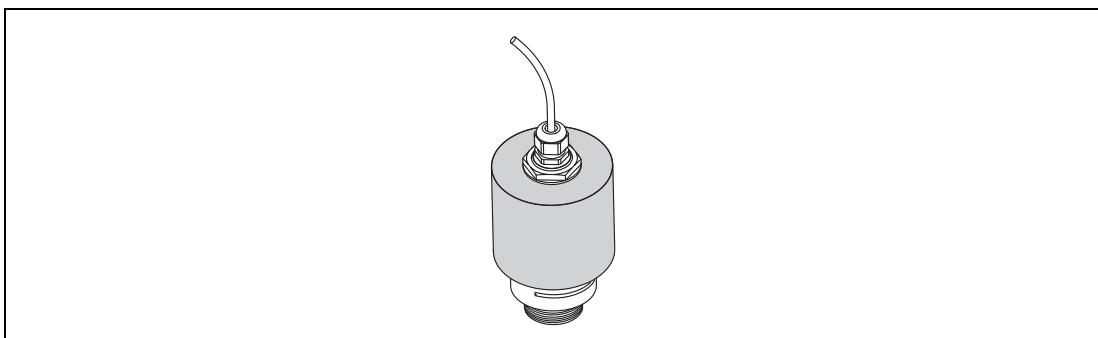

Figure 8.7 Weather protection cover with 40 mm (1.5 inch) antenna

Note

The sensor is not completely covered by the weather protection cover.



8.1.8 Using the Flooding Protection Tube

The flooding protection tube ensures the sensor measures the maximum level even if it is completely flooded.

In free-field installations and/or in applications where there is a risk of flooding, the flooding protection tube must be used.

The flooding protection tube can be ordered as an accessory or together with the device via the ordering option **Accessory enclosed**.

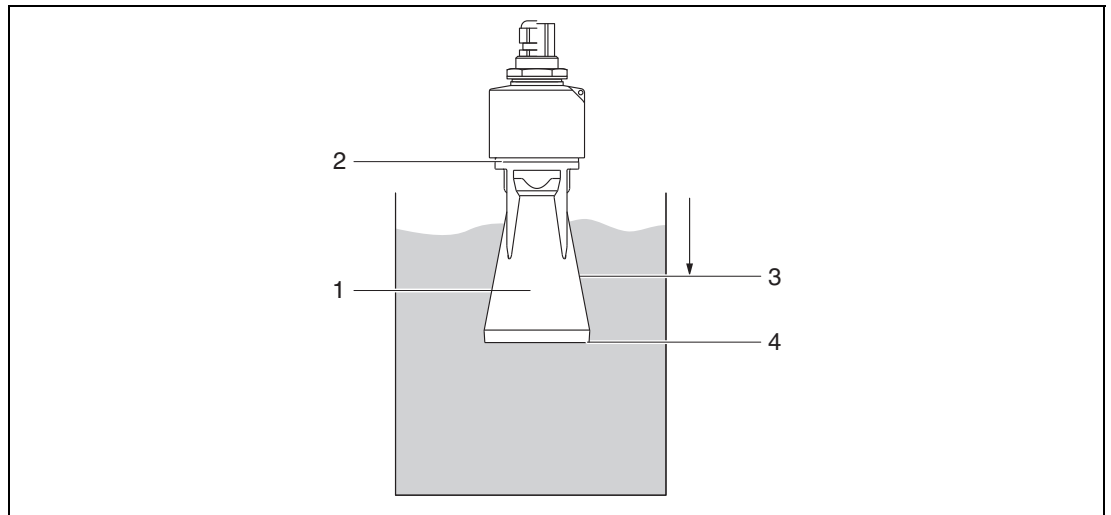

Figure 8.8 Function of flooding protection tube

- 1 Air pocket
- 2 O-ring (EPDM) seal
- 3 Blocking distance
- 4 Max. level

The tube is screwed directly onto the sensor and seals off the system by means of an O-ring making it air-tight. In the event of flooding, the air pocket that formed in the tube ensures the measurement of the maximum level at the end of the tube. Due to the fact that the blocking distance is inside the tube, multiple echoes are not analyzed.

8.1.9 Installation with Mounting Bracket, Adjustable

The mounting bracket is available as an accessory.

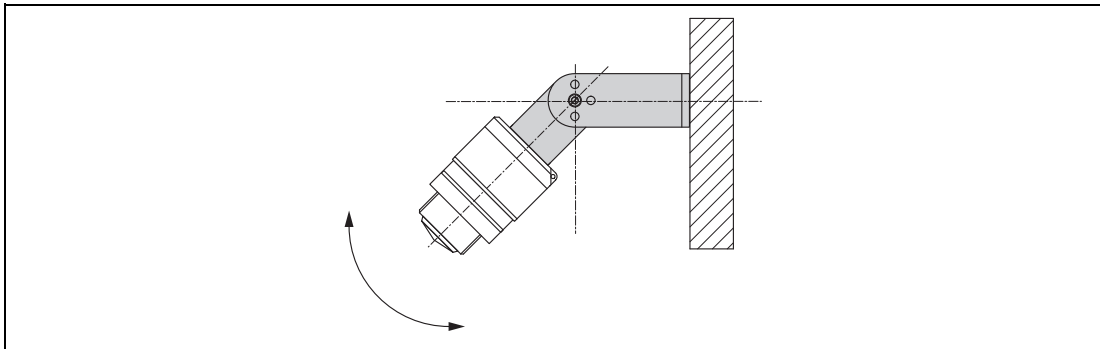

Figure 8.9 Installation with mounting bracket, adjustable

- Wall or ceiling installation is possible.
- Using the mounting bracket, position the antenna so that it is perpendicular to the product surface.



Caution!

There is no conductive connection between the mounting bracket and transmitter housing. Electrostatic charging possible.

Integrate the mounting bracket in the local potential equalization system.

8.1.10 Cantilever Installation, with Pivot

The cantilever, wall bracket and mounting frame are available as accessories.

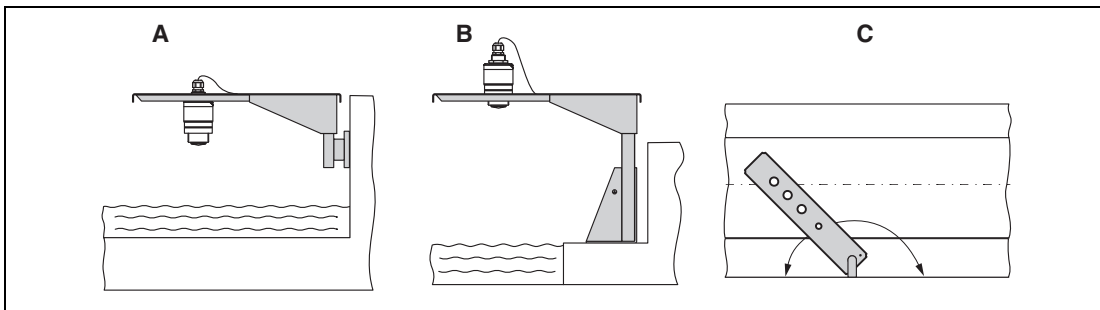

Figure 8.10 Cantilever installation, with pivot

- A** Cantilever with wall bracket
- B** Cantilever with mounting frame
- C** Cantilever can be turned (e. g., in order to position the device over the center of the flume)

8.1.11 Installation of Horizontal Mounting Bracket for Sewer Shafts

The horizontal mounting bracket is available as an accessory.

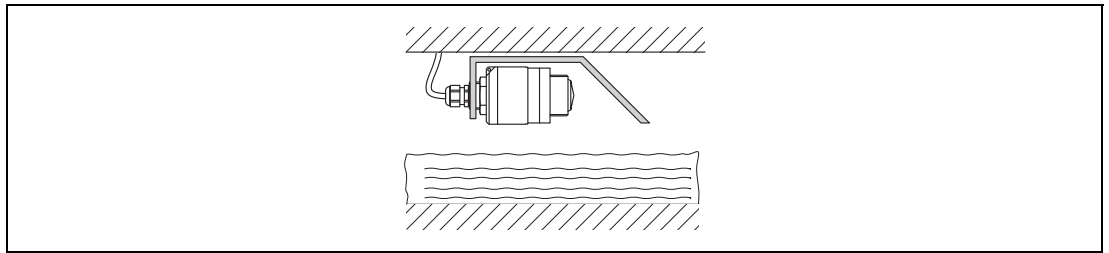

Figure 8.11 Installation of horizontal mounting bracket for sewer shafts

8.1.12 Mounting in a Shaft

The pivoted mounting bracket is available as an accessory.

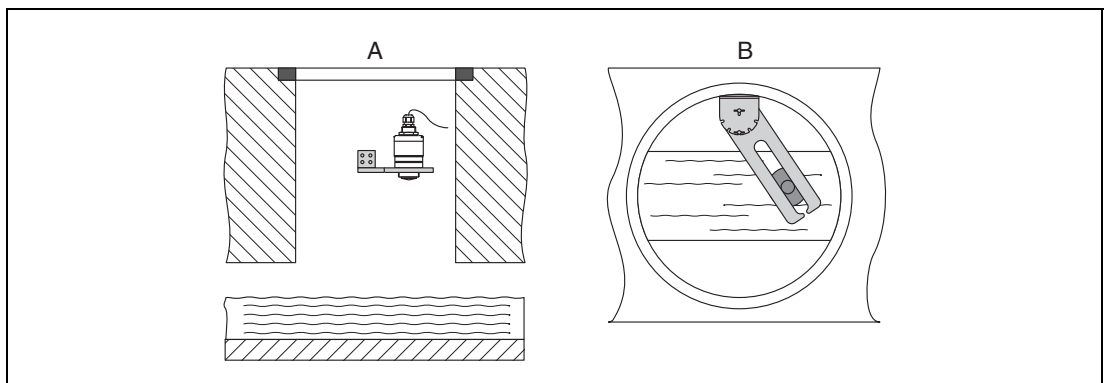

Figure 8.12 Mounting in a shaft, pivotable and adjustable

- A** Arm with wall bracket
- B** Pivotable and adjustable arm (e. g. to align the device with the center of a channel)

8.2 Post-installation Check

- Is the device or cable undamaged (visual inspection)?
- Is the device adequately protected from wet conditions and direct sunlight?
- Is the device properly secured?

9 Electrical Connection

9.1 Cable Assignment

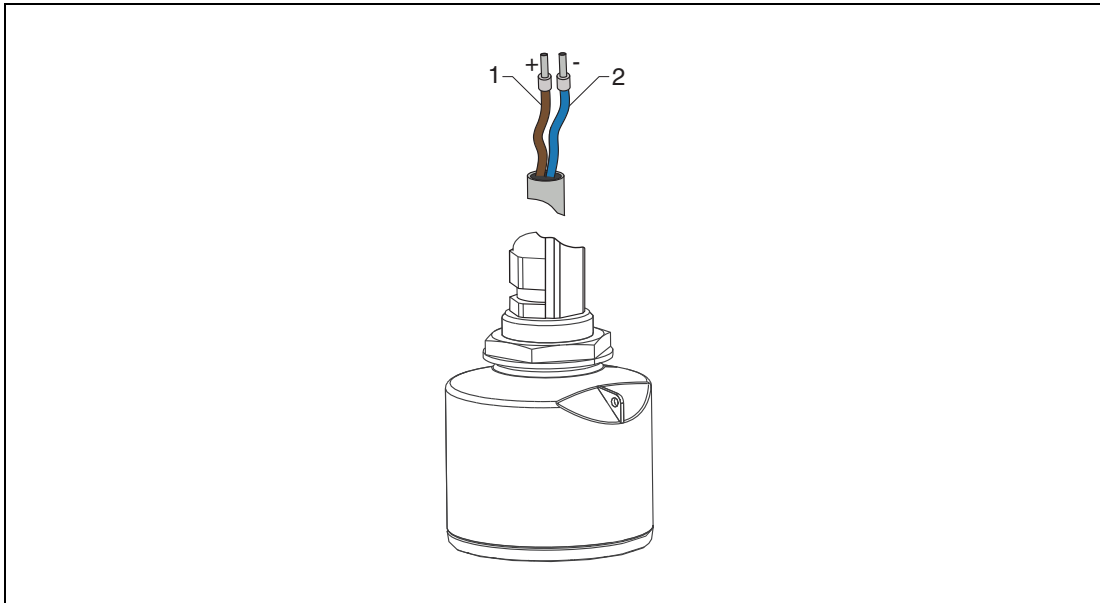

Figure 9.1 Cable assignment

- 1 Plus, brown wire
- 2 Minus, blue wire

9.2 Supply Voltage

10.5 to 30 V DC

An external power supply is necessary.

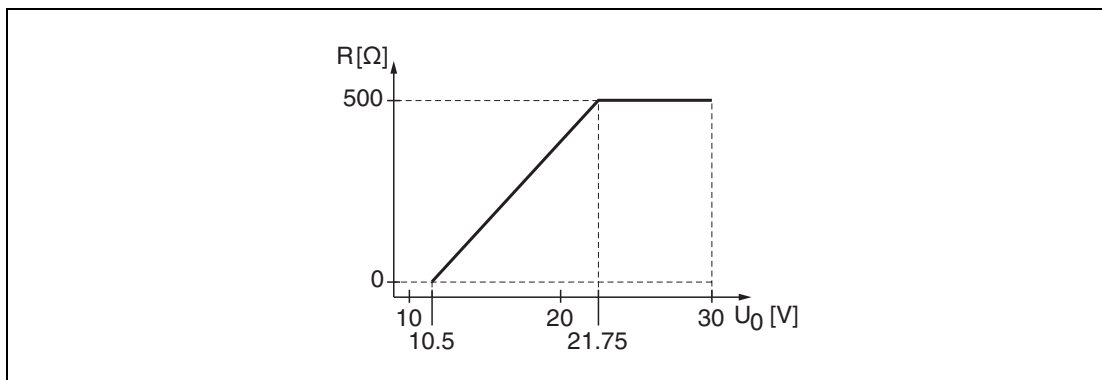

Figure 9.2 Maximum load R , depending on supply voltage U_0 of power supply unit

Battery operation

The sensor's *Bluetooth*[®] wireless technology communication can be disabled to increase the operating life of the battery.

Potential equalization

No special measures for potential equalization are required.



Note

Various power supply units can be ordered as an accessory from Pepperl+Fuchs.

9.3

Connecting the Device

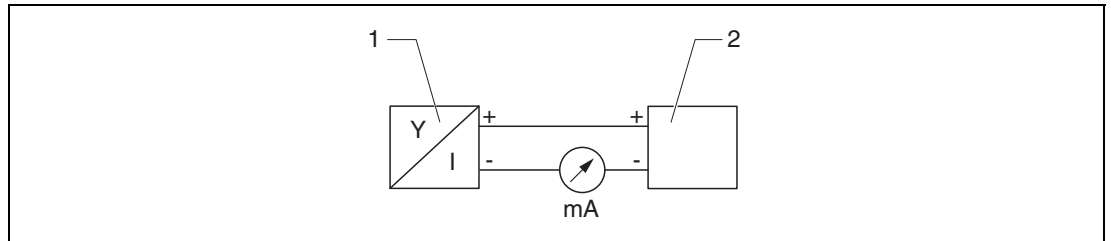

Figure 9.3 Block diagram of HART connection

- 1 Device
- 2 Power supply

9.4

Post-connection Check

- Is the device or cable undamaged (visual inspection)?
- Do the mounted cables have adequate strain relief?
- Are the cable glands mounted and firmly tightened?
- Does the supply voltage match the specifications on the nameplate?
- No reverse polarity, is terminal assignment correct?

10 Operability

10.1 Operating Concept

- 4 to 20 mA
- P+F Level (app) via *Bluetooth*[®] wireless technology

10.2 Operation via *Bluetooth*[®] Wireless Technology

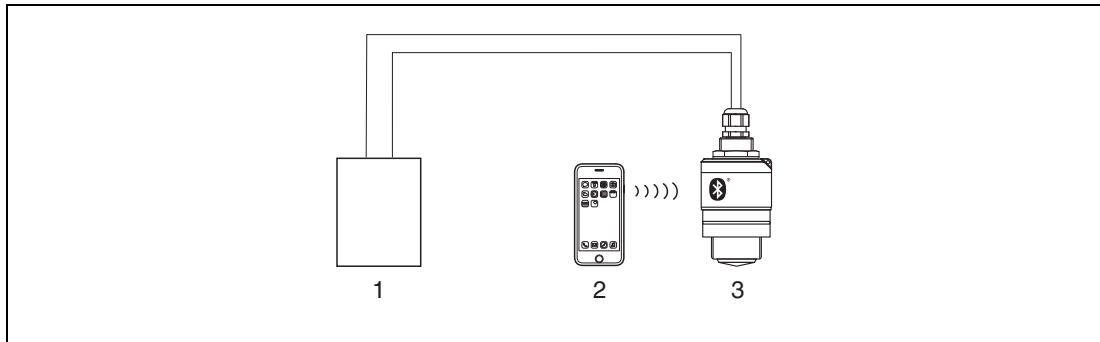

Figure 10.1 Possibilities for remote operation via *Bluetooth*[®] wireless technology

- 1 Transmitter power supply
- 2 Smartphone/Tablet with P+F Level (app)
- 3 Signal converter with *Bluetooth*[®] wireless technology

11 Commissioning and Operation

11.1 Commissioning via P+F Level (App)

11.1.1 Device Requirements

Commissioning via P+F Level is only possible if the device has Bluetooth capability (Bluetooth module installed at the factory prior to delivery or retrofitted).

11.1.2 P+F Level System Requirements

P+F Level is available as a download from the Google Play Store for Android devices and from the iTunes Store for iOS devices.

- Devices with iOS:
iPhone 4S or higher from iOS 9; iPad 2 or higher from iOS 9; iPod touch 5th generation or higher from iOS 9
- Devices with Android:
From Android 4.4 KitKat and *Bluetooth*® 4.0

11.1.3 Commissioning



Downloading and Installing P+F Level

1. Enter **P+F Level** in the search field of the app store.



Figure 11.1 App stores

2. Install P+F Level.
3. Start P+F Level.
4. Select device from livelist displayed.
5. Enter the login data:
 - ↳ User name: admin
 - ↳ Password: serial number of the device
6. Tap the icons for more information.



Note!

After logging in for the first time, change the password!

11.1.4 Envelope Curve Display in P+F Level

Envelope curves can be displayed and recorded in P+F Level.

In addition to the envelope curve, the following values are displayed:

- D = Distance
- L = Level
- A = Absolute amplitude
- With screenshots, the displayed section (zoom function) is saved.
- With video sequences, the whole area without zoom function is saved all the time.

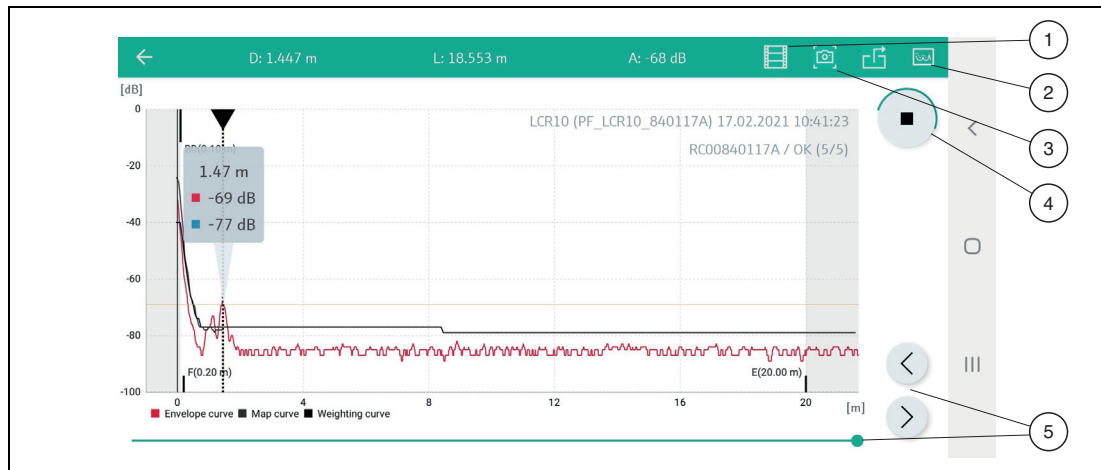

Figure 11.2 Envelope curve display (sample) in P+F Level for Android

- 1 Record video
- 2 Display mapping menu
- 3 Create screenshot
- 4 Start/stop video recording
- 5 Move time on time axis

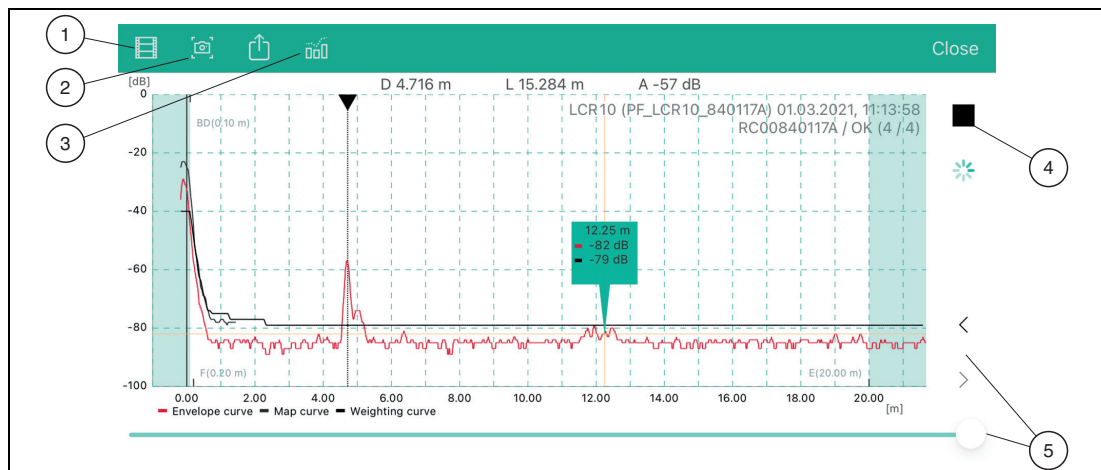

Figure 11.3 Envelope curve display (sample) in P+F Level for iOS

- 1 Record video
- 2 Create screenshot
- 3 Display mapping menu
- 4 Start/stop video recording
- 5 Move time on time axis

12 Diagnostics and Troubleshooting

12.1 General Errors

Error	Possible cause	Solution
Device does not respond.	Supply voltage does not match the specification on the nameplate.	Apply correct voltage.
	The polarity of the supply voltage is wrong.	Correct the polarity.
	The cables do not contact the terminals properly.	Ensure electrical contact between the cable and the terminal.
Device measures incorrectly.	Configuration error	<ul style="list-style-type: none"> • Check and correct the parameter configuration. • Carry out mapping.
Linearized output value not plausible.	Linearization error	PACTware: Check linearization table. P+F Level: Check linearization table. Check the vessel selection in the linearization module.

Table 12.1

12.2 Error – P+F Level Operation

Error	Possible case	Solution
Device is not visible in the live list.	No Bluetooth connection	Enable Bluetooth function on smartphone or tablet. Bluetooth function of sensor disabled, perform recovery sequence.
	The device is already connected with another smartphone/tablet.	Only one point-to-point connection is established between a sensor and a smartphone or tablet.
Device is visible in the live list but cannot be accessed via P+F Level.	Android end device	Is the location function permitted for the app, was it approved the first time?
		GPS or positioning function must be activated for certain Android versions in conjunction with Bluetooth.
		Activate GPS – close the app fully and restart – enable the positioning function for the app.
Device is visible in the live list but cannot be accessed via P+F Level.	Apple end device	Log in as standard. Enter user name admin . Enter initial password (device serial number) paying attention to lower/upper case.
Login via P+F Level not possible.	Device is being put into operation for the first time.	Enter initial password (device serial number) and change. Pay attention to lower/upper case when entering the serial number.
Device cannot be operated via P+F Level.	Incorrect password entered.	Enter correct password.
Device cannot be operated via P+F Level.	Password forgotten.	Contact the Pepperl+Fuchs service department.
Device cannot be operated via P+F Level.	The sensor temperature is too high.	If the ambient temperature results in an elevated sensor temperature of > 60 °C (140 °F), Bluetooth communication may be disabled. Shield the device, isolate it and cool it down if necessary.

Table 12.2

12.3 Diagnostic Event in the Operating Tool

If a diagnostic event is present in the device, the status signal appears in the top left status area of the operating tool along with the corresponding symbol for the event level in accordance with NAMUR NE 107:

- Failure (F)
- Function check (C)
- Out of specification (S)
- Maintenance required (M)



Calling up Remedial Measures

Navigate to the **Diagnostics** menu

↳ In the **Actual diagnostics** parameter the diagnostic event is shown with event text.

Your automation, our passion.

Explosion Protection

- Intrinsic Safety Barriers
- Signal Conditioners
- FieldConnex® Fieldbus
- Remote I/O Systems
- Electrical Ex Equipment
- Purge and Pressurization
- Industrial HMI
- Mobile Computing and Communications
- HART Interface Solutions
- Surge Protection
- Wireless Solutions
- Level Measurement

Industrial Sensors

- Proximity Sensors
- Photoelectric Sensors
- Industrial Vision
- Ultrasonic Sensors
- Rotary Encoders
- Positioning Systems
- Inclination and Acceleration Sensors
- Fieldbus Modules
- AS-Interface
- Identification Systems
- Displays and Signal Processing
- Connectivity

Pepperl+Fuchs Quality

Download our latest policy here:

www.pepperl-fuchs.com/quality



71461488