

ICA-A*-IO-V1

IO-Link Analog Converter

Manual



 **IO-Link**

Your automation, our passion.

 **PEPPERL+FUCHS**

With regard to the supply of products, the current issue of the following document is applicable:
The General Terms of Delivery for Products and Services of the Electrical Industry, published
by the Central Association of the Electrical Industry (Zentralverband Elektrotechnik und Elek-
troindustrie (ZVEI) e.V.) in its most recent version as well as the supplementary clause:
"Expanded reservation of proprietorship"

Worldwide

Pepperl+Fuchs Group
Lilienthalstr. 200
68307 Mannheim
Germany
Phone: +49 621 776 - 0
E-mail: info@de.pepperl-fuchs.com

North American Headquarters

Pepperl+Fuchs Inc.
1600 Enterprise Parkway
Twinsburg, Ohio 44087
USA
Phone: +1 330 425-3555
E-mail: sales@us.pepperl-fuchs.com

Asia Headquarters

Pepperl+Fuchs Pte. Ltd.
P+F Building
18 Ayer Rajah Crescent
Singapore 139942
Phone: +65 6779-9091
E-mail: sales@sg.pepperl-fuchs.com
<https://www.pepperl-fuchs.com>

1	Introduction	4
1.1	Content of this Document.....	4
1.2	Target Group, Personnel	4
1.3	Symbols Used	5
1.4	General Safety Notice.....	6
2	Product Description	7
2.1	Intended Use	7
2.2	Versions	7
2.3	Dimensions.....	7
2.4	LED Indicators	8
2.4.1	LED 1.....	8
2.4.2	LED 2.....	9
2.5	Interfaces and Connections	9
2.6	Accessories.....	14
3	Installation	15
3.1	Preparing for Mounting	15
3.2	Mounting.....	15
3.3	Connection	16
4	Operation	17
4.1	IO-Link Parameters	17
5	Maintenance	19
5.1	Servicing.....	19
6	Glossary and List of Abbreviations	20

1 Introduction

1.1 Content of this Document

This document contains information required to use the product in the relevant phases of the product life cycle. This may include information on the following:

- Product identification
- Delivery, transport, and storage
- Mounting and installation
- Commissioning and operation
- Maintenance and repair
- Troubleshooting
- Dismounting
- Disposal



Note

For full information on the product, refer to the further documentation on the Internet at www.pepperl-fuchs.com.



Note

For specific device information such as the year of construction, scan the QR code on the device. As an alternative, enter the serial number in the serial number search at www.pepperl-fuchs.com.

The documentation comprises the following parts:

- This document
- Datasheet

In addition, the documentation may comprise the following parts, if applicable:

- EU-type examination certificate
- EU declaration of conformity
- Attestation of conformity
- Certificates
- Control drawings
- Instruction manual
- Functional safety manual
- Other documents

1.2 Target Group, Personnel

Responsibility for planning, assembly, commissioning, operation, maintenance, and dismantling lies with the plant operator.

Only appropriately trained and qualified personnel may carry out mounting, installation, commissioning, operation, maintenance, and dismantling of the product. The personnel must have read and understood the instruction manual and the further documentation.

Prior to using the product make yourself familiar with it. Read the document carefully.

1.3 Symbols Used

This document contains symbols for the identification of warning messages and of informative messages.

Warning Messages

You will find warning messages, whenever dangers may arise from your actions. It is mandatory that you observe these warning messages for your personal safety and in order to avoid property damage.

Depending on the risk level, the warning messages are displayed in descending order as follows:



Danger!

This symbol indicates an imminent danger.

Non-observance will result in personal injury or death.



Warning!

This symbol indicates a possible fault or danger.

Non-observance may cause personal injury or serious property damage.



Caution!

This symbol indicates a possible fault.

Non-observance could interrupt the device and any connected systems and plants, or result in their complete failure.

Informative Symbols



Note

This symbol brings important information to your attention.



Action

This symbol indicates a paragraph with instructions. You are prompted to perform an action or a sequence of actions.

1.4 General Safety Notice



Danger!

Death or serious injury due to electric shock.

High electrical voltage in the machine/plant.

When working on the device, observe the five safety rules of electrical engineering.

According to DIN VDE 0105-100—Operation of electrical installations—Part 100: General requirements

Protect people and devices from high electrical voltage:

- Disconnect
- Secure against restart
- Make sure that all poles are de-energized
- Ground and short circuit
- Cover or shield adjacent live parts

The device is only approved for appropriate and intended use. Ignoring these instructions will void any warranty and absolve the manufacturer from any liability.

Electrostatic Charge

Avoid electrostatic charges which could result in electrostatic discharges while installing, operating, or maintaining the device.

Ensure adequate grounding of people and equipment.

Disconnect the device from the power supply before unplugging or plugging in connectors and cables.

When taking measurements on electrostatic-sensitive devices, observe the following points:

- Discharge volt-free measuring devices for a short time.
- Ground the measuring devices.

If you are modifying electrostatic-sensitive devices, use a grounded soldering iron.

Operation, Maintenance

Use the device only within the specified ambient and operating conditions.

Observe directives, standards, and national laws applicable to the intended use and the operating location.

Do not use the device outdoors, in potentially explosive atmospheres (explosion protection zones) or for permanent operation in liquids.

Only operate the device in a perfect technical condition.

Do not modify or manipulate the device.

If cleaning is required, do not use high pressure.

Storage, Transport, Disposal

Always store and transport the device in the original packaging.

The device, built-in components, packaging, and any batteries contained within must be disposed in compliance with the applicable laws and guidelines of the respective country.

2 Product Description

2.1 Intended Use

The device described in the manual is used for communication and process control. Use the device for general control and automation tasks.

The device is designed for industrial use up to the IP67/IP69K degree of protection.

The intended use also includes EMC-compliant electrical installation.



Caution!

Device interference is possible in mixed and residential areas!

This installation may cause radio interference in mixed and residential areas.

- Observe the applicable standards for the mixed or residential area.
- Take appropriate measures to prevent radio interference.

2.2 Versions

The manual applies to the following versions.

Analog input (I/U) to IO-Link converter

Item number	Order designation
70128166	ICA-AI-I/U-IO-V1

IO-Link to analog output converter (I/U)

Item number	Order designation
70128167	ICA-AO-I/U-IO-V1

Temperature input converter for RTD resistor temperature sensors to IO-Link

Item number	Order designation
70163607	ICA-AI-RTD-IO-V1

2.3 Dimensions

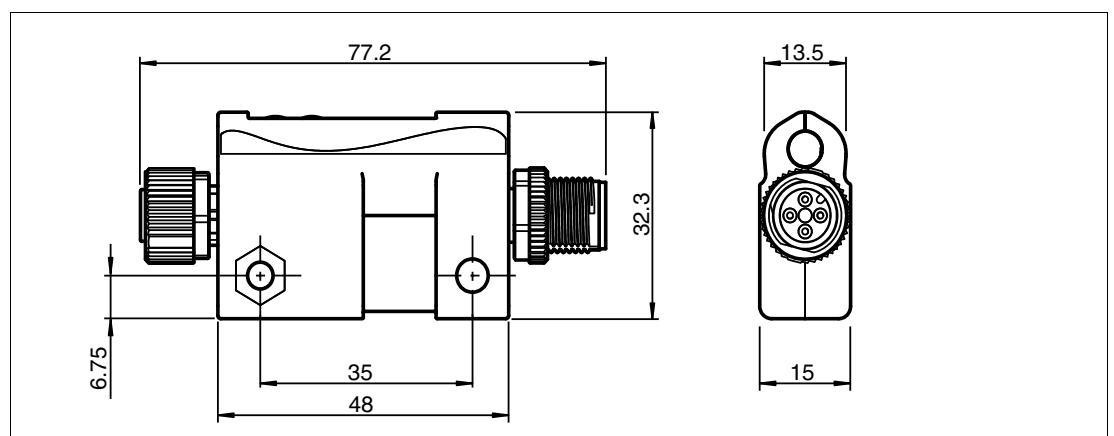

Figure 2.1

2.4 LED Indicators

The device has 2 LEDs for the status indicator.

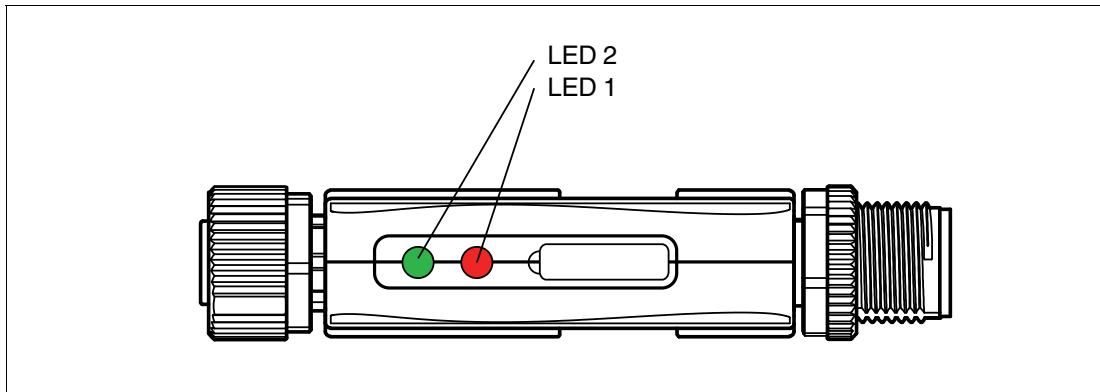

Figure 2.2

- 1 LED 1: Device status / diagnostics
- 2 LED 2: IO-Link status

2.4.1 LED 1

LED 1 displays device and function status information. Green indicates the general device status. Red indicates the status of the analog channel.



Note

If the red and green components light up simultaneously, the color of LED 1 may appear orange.

Device status green

Status	Description
Green	Device is on, status OK
Green flashing (1 Hz)	Device supply low voltage ($U_B < 18\text{ V}$)
Green asymmetrical flashing (1 Hz: 250 ms on/750 ms off)	Device supply overvoltage ($U_B > 30\text{ V}$)
Green off	No voltage supply to device

Table 2.1



Note

If multiple diagnostics occur at the same time, the LED status is prioritized according to the order in the respective table. The top entry has the highest priority.

Device status red

Status	Description
Red flashing (1 Hz)	Sensor data exceeds the range
Red flashing (2 Hz)	Converter excess temperature
Red asymmetrical flashing (1 Hz: 250 ms on/750 ms off)	Sensor lead breakage
Red off	OK

Table 2.2

2.4.2 LED 2

IO-Link status

LED 2 indicates the status of the IO-Link communication connection.

Status	Description
Green	No IO-Link process data communication, pre-operate mode
Green asymmetrical flashing (1 Hz: 250 ms on/750 ms off)	IO-Link communication, operate mode
Off	No IO-Link communication

Table 2.3

2.5 Interfaces and Connections

Plug assignment

ICA-AI-I/U-IO-V1

Connection for	Connectors	Plug type / assignment
IO-Link		M12, 4-pin, plug, A-coded 1: +24 V (L+) 2: n.c. 3: GND (L-) 4: C/Q
Analog input		M12, 4-pin, socket, A-coded 1: +24 V (L+) 2: AI 3: GND (L-) 4: n.c.

Table 2.4

ICA-AO-I/U-IO-V1

Connection for	Connectors	Plug type / assignment
IO-Link		M12, 4-pin, plug, A-coded 1: +24 V (L+) 2: n.c. 3: GND (L-) 4: C/Q
Analog output		M12, 4-pin, socket, A-coded 1: +24 V (L+) 2: n.c. 3: GND (L-) 4: AO

Table 2.5

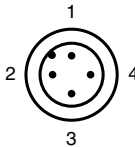
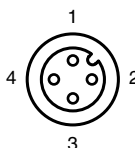
ICA-AI-RTD-IO-V1

Connection for	Connectors	Plug type / assignment
IO-Link		M12, 4-pin, plug, A-coded 1: +24 V (L+) 2: n.c. 3: GND (L-) 4: C/Q
Input RTD resistor temperature sensors		M12, 5-pin, socket, A-coded 1: RD 1 2: RD 2 3: WH 1 4: WH 2 5: n.c.

Table 2.6

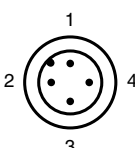
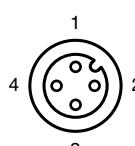
Analog inputs

Sensors with analog output can be used depending on the adapter type.

Sensors with current output (0/4 mA ... 20 mA)

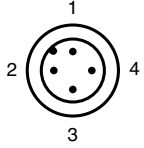
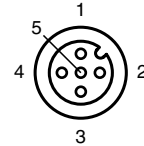
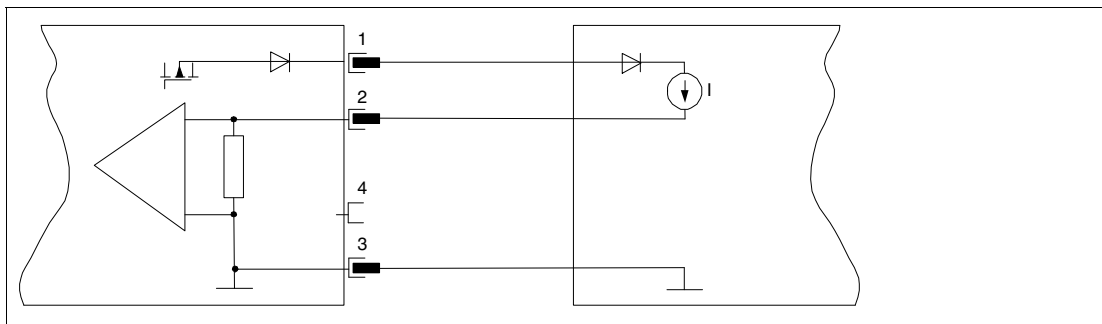

Figure 2.3 ICA-AI-I/U-IO-V1

- 1 +24 V (L+)
- 2 AI (current)
- 3 GND (L-)
- 4 n.c.

Sensors with voltage output (-10/0 V ... +10 V)

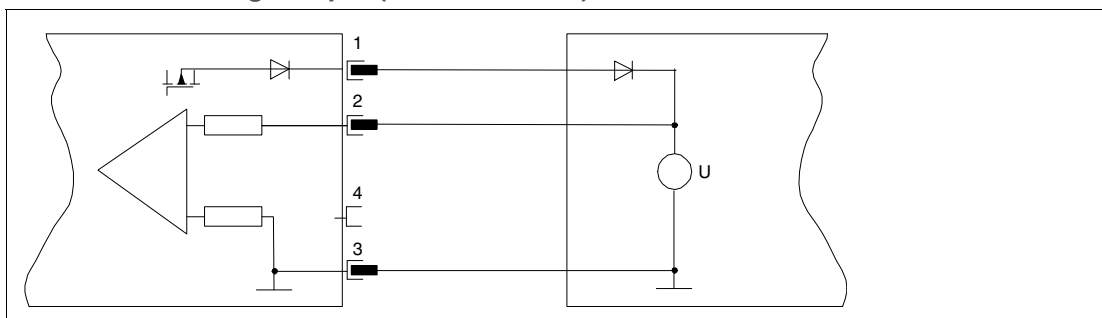

Figure 2.4 ICA-AI-I/U-IO-V1

- 1 +24 V (L+)
- 2 AI (voltage)
- 3 GND (L-)
- 4 n.c.

Analog outputs

Actuators with analog input can be used depending on the adapter type.

Actuators with current input (0/4 mA ... 20 mA)

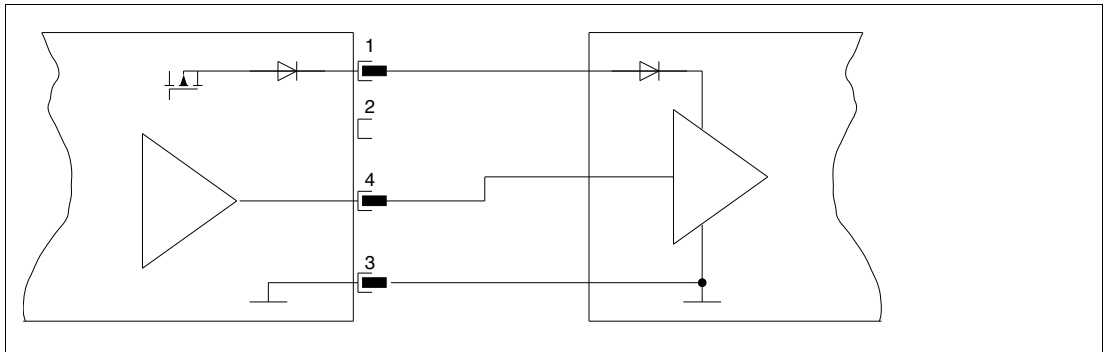

Figure 2.5 ICA-AO-I/U-IO-V1

- 1 +24 V (L+)
- 2 n.c.
- 3 GND (L-)
- 4 AO (current)

Actuators with voltage input (-10/0 V ... +10 V)

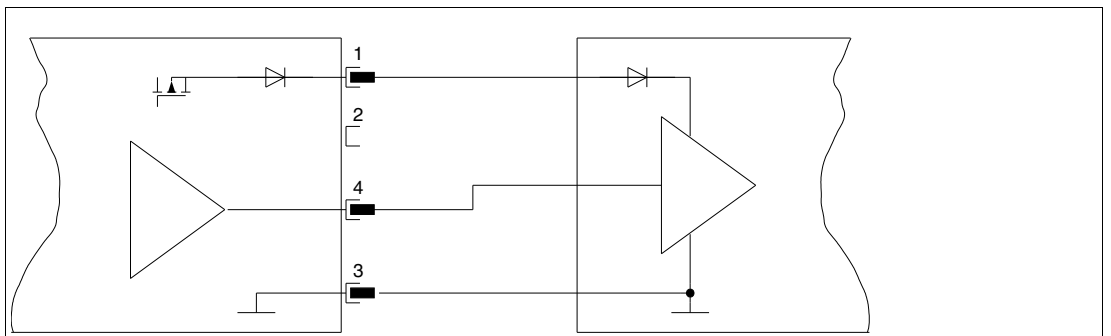

Figure 2.6 ICA-AO-I/U-IO-V1

- 1 +24 V (L+)
- 2 n.c.
- 3 GND (L-)
- 4 AO (voltage)

Temperature input for RTD resistor temperature sensors

RTD sensors can be connected as 2-, 3-, or 4-core versions.

2-wire version

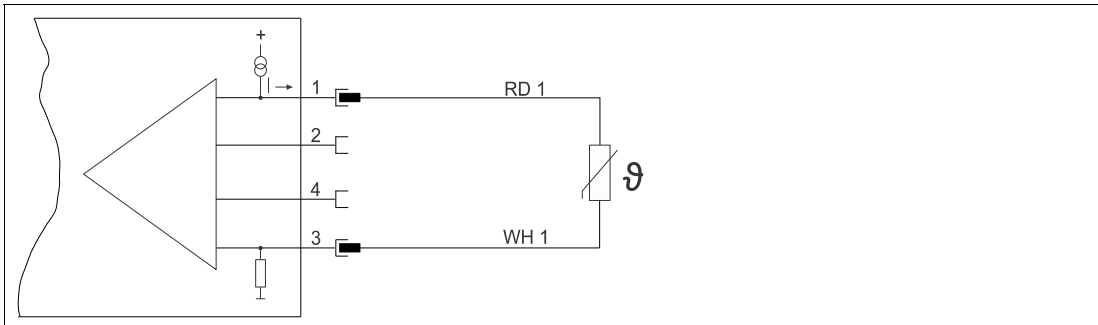

Figure 2.7 ICA-AI-RTD-IO-V1

- 1 RD 1
- 3 WH 1

3-wire version

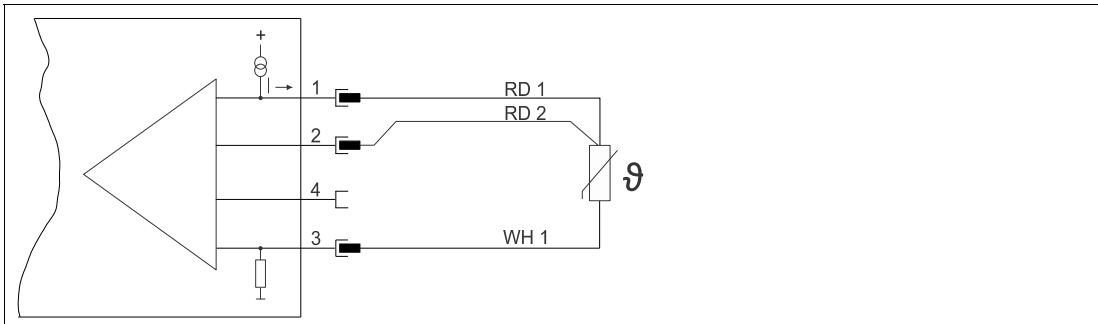

Figure 2.8 ICA-AI-RTD-IO-V1

- 1 RD 1
- 2 RD 2
- 3 WH 1

4-wire version

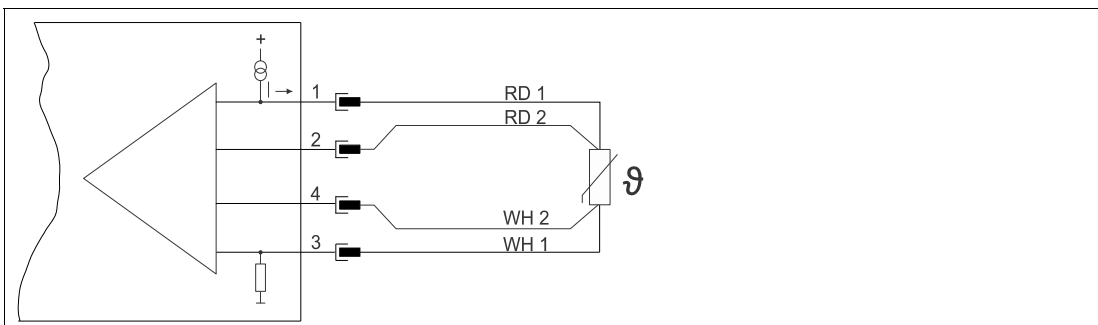

Figure 2.9 ICA-AI-RTD-IO-V1

- 1 RD 1
- 2 RD 2
- 3 WH 1
- 4 WH 2

Measuring ranges

PT100, PT200, PT500, PT1000

Nominal measuring range	-200 °C ... +850 °C	
Overrange	-220 °C ... +1000 °C	
Resolution	0.1 °C	
Measurement accuracy	4-conductor measurement	<0.1 % (full-scale)
	3-conductor measurement	<0.2 % (full-scale)
	2-conductor measurement ¹	<0.2 % (full-scale)

1. Line resistance = 0 Ω

PT100 climate

Nominal measuring range	-120 °C ... +130 °C	
Overrange	-145 °C ... +155 °C	
Resolution	0.01 °C	
Measurement accuracy	4-conductor measurement	<0.2 % (full-scale)

Ohms 0 Ω ... 3000 Ω

Nominal measuring range	0 Ω ... 3000 Ω	
Overrange	0 Ω ... 3251.1 Ω	
Resolution	S7 format	0.1085 Ω
Measurement accuracy	4-conductor measurement	<0.05 % (full-scale)
	3-conductor measurement	<0.1 % (full-scale)
	2-conductor measurement	<0.1 % (full-scale)

IO-Link interface

All IO-Link masters that support IO-Link standard 1.12 or 1.0 can be used.

Sensors with current output (0/4 mA ... 20 mA)

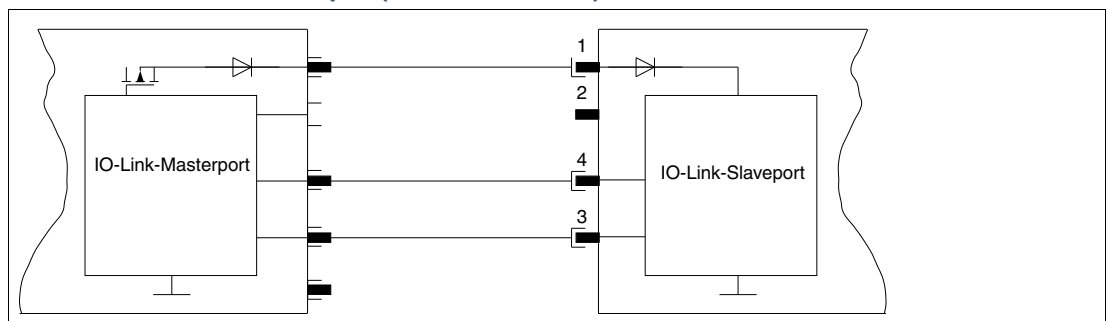

Figure 2.10 IO-Link

- 1 +24 V (L+)
- 2 n.c.
- 3 GND (L-)
- 4 C/Q

2.6 Accessories

System Components

Model code	Description
MH Y+T-SPLITTER HOLDER	Modular universal holder for M12 T-splitter cordsets and M12 Y-splitter cordsets

Tools

Model code	Description
MH V1-SCREWDRIVER	Torque screwdriver (0.6 Nm)
MH V1-BIT M12	Plug-in attachment for M12

3 Installation

3.1 Preparing for Mounting



Danger!

Death or serious injury due to electric shock.

High electrical voltage in the machine/plant.

- When working on the device, observe the five safety rules of electrical engineering.
- Only connect supplies that provide protection against electric shock according to SELV or PELV.
Use a power supply that permits a maximum of 60 V DC or 25 V AC in the event of a fault.

- Make sure that the sensor or actuator is located in the immediate vicinity of the mounting location.
- To avoid mechanical stress during mounting, make sure that the mounting surface is level.
- To ground the ground strap, ground the mounting surface.
- Use short cable routes to all components.
- Make sure there is enough space to replace the device and plug in the connectors.
- Observe the environmental and operational conditions of the device during mounting and installation.
- Protect the connection lines from tearing.
- Mount the device in such a way that the LED displays of the device are visible during operation.

3.2 Mounting



Caution!

Property damage due to unsuitable fastening screws!

The use of unsuitable fastening screws can cause property damage.

- Use fastening screws that are appropriate for the type of mounting surface.

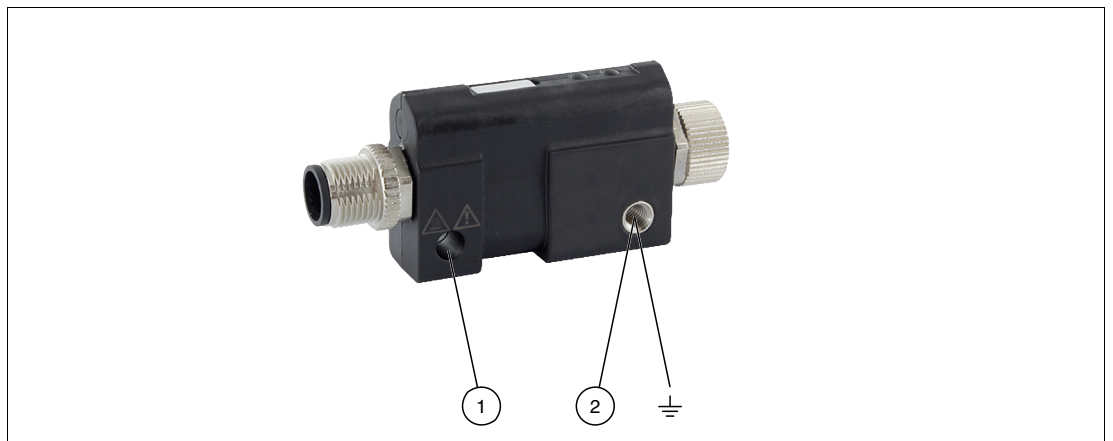

Figure 3.1

- 1 M5 mounting hole diameter 5.2 mm
- 2 M5 FE connection sleeve

Use an M5 screwdriver (torque 2.5 Nm).

3.3 Connection

**Caution!**

Property damage due to unsuitable fastening screws!

The use of unsuitable fastening screws can cause property damage.

- Use fastening screws that are appropriate for the type of mounting surface.

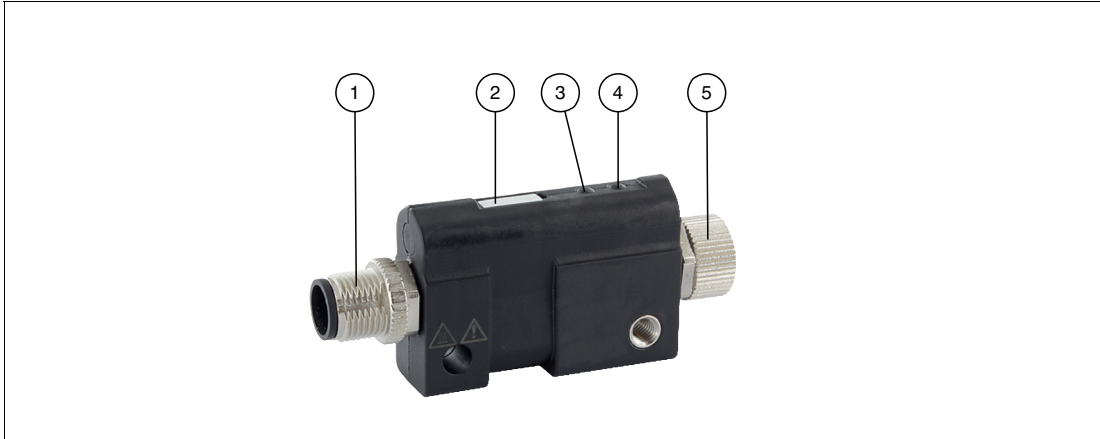

Figure 3.2

- 1 IO-Link Connection
- 2 Name plate, replaceable
- 3 LED 1: Device status / diagnostics
- 4 LED 2: IO-Link status
- 5 Analog input/output

Connection lines

**Caution!**

Risk of injury due to high temperatures!

High temperatures above 70 °C can cause minor injuries and damage cables.

- Wear thermally appropriate protective gloves.
- Use only thermally appropriate cables.

Use an M12 mounting tool (max. tightening torque 0.6 Nm).

4 Operation

4.1 IO-Link parameters



Note

All details of the IO-Link parameters can be found in the IO device description (IODD) and the parameter datasheet for the device on our website www.pepperl-fuchs.com.



Parameter datasheet and IODD

1. Open our website at www.pepperl-fuchs.com
2. Enter the order designation or part number of your product in the search field.

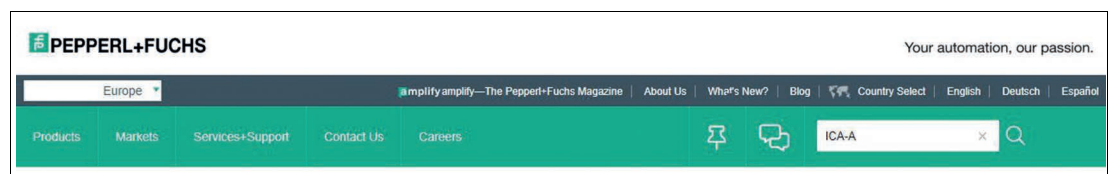

Figure 4.1

3. Open the product detail page.
4. Click the Documents tab (1) to list the different documents for the product.

IO-Link converter ICA-AI-I/U-IO-V1

- IO-Link interface
- IP67
- Analog input can be parameterized (current/voltage)
- Current input can be parameterized as 0 ... 20 mA/4 ... 20 mA
- Voltage input can be parameterized as -10 ... 10 V/0 ... 10 V

Active demand planning class: AI

1 Documents Approvals+Certificates Software Associated Products

Please note: All product-related documents, such as certificates, declarations of conformity, etc., which were issued prior to the conversion under the name Pepperl+Fuchs GmbH or Pepperl+Fuchs AG, also apply to Pepperl+Fuchs SE.

Download the complete datasheet as a PDF: ENG Download PDF

Documents: ICA-AI-I/U-IO-V1

Manuals	Language	File Type	File Size
Manual ICA-AI-I/U-IO-V1 and ICA-AO-I/U-IO-V1	ENG	PDF	814 KB
Handbuch ICA-AI-I/U-IO-V1 und ICA-AO-I/U-IO-V1	GER	PDF	827 KB
Short instructions, safety information			
2 IO-Link Parameter Datasheet ICA-AI-I/U-IO-V1	ENG	PDF	669 KB

Figure 4.2

↳ You can find the parameter datasheet under "Quick reference guides, Safety information" (2).

5. Click the Software tab (1) to list the software for the product.

[Add to Watch List](#)

IO-Link converter ICA-AI-I/U-IO-V1

- IO-Link interface
- IP67
- Analog input can be parameterized (current/voltage)
- Current input can be parameterized as 0 ... 20 mA/4 ... 20 mA
- Voltage input can be parameterized as -10 ... 10 V/0 ... 10 V

Sensork **40**

Active
demand planning class: AI

Datasheet Documents Approvals+Certificates **Software** (1) Associated Products

Please note: All product-related documents, such as certificates, declarations of conformity, etc., which were issued prior to the conversion under the name Pepperl+Fuchs GmbH or Pepperl+Fuchs AG, also apply to Pepperl+Fuchs SE.

Download the complete datasheet as a PDF: ENG [Download PDF](#)

Software: ICA-AI-I/U-IO-V1

IO Device Description (IODD)	Release Info	File Type	File Size
2 IODD for ICA-AI-I/U-IO / IODD fuer ICA-AI-I/U-IO	V1.00.000 / 2020-08-01	ZIP	156 KB

Figure 4.3

↳ You can find the IODD under "IO Device Description (IODD)" (2).

5 Maintenance

5.1 Servicing

The device bus nodes and modules are maintenance-free.

No inspection and maintenance intervals are required for ongoing operation.

Replace defective bus nodes and/or defective modules.

6 Glossary and List of Abbreviations

Abbreviation/ Designation	Meaning
AI	Analog input
AO	Analog output
Bit	Binary digit
Byte	1 byte equals 8 bits
DC	Diagnostic coverage / degree of detection of errors
DIN	Deutsches Institut für Normung (German Institute for Standardization)
EMC	Electromagnetic compatibility
EN	European standard
ESD	Electrostatic discharge
FE	Functional earth
IO-Link	Standardized communication system for connecting intelligent sensors and actuators to an automation system
IP67	6: Dust-proof, protection against access with a wire 7: Protection against temporary immersion
ISDU (IO-Link)	Indexed Service Data Unit
LED	Light-emitting diode
MTTF _d	Mean time to (dangerous) failure
n.c.	Not connected
PELV	Protective extra-low voltage
RTD	Resistant temperature detector
SELV	Safety extra-low voltage
TH	T/C thermocouple

Table 6.1

Your automation, our passion.

Explosion Protection

- Intrinsic Safety Barriers
- Signal Conditioners
- FieldConnex® Fieldbus
- Remote I/O Systems
- Electrical Ex Equipment
- Purge and Pressurization
- Industrial HMI
- Mobile Computing and Communications
- HART Interface Solutions
- Surge Protection
- Wireless Solutions
- Level Measurement

Industrial Sensors

- Proximity Sensors
- Photoelectric Sensors
- Industrial Vision
- Ultrasonic Sensors
- Rotary Encoders
- Positioning Systems
- Inclination and Acceleration Sensors
- Fieldbus Modules
- AS-Interface
- Identification Systems
- Displays and Signal Processing
- Connectivity

Pepperl+Fuchs Quality

Download our latest policy here:

www.pepperl-fuchs.com/quality

