

ICA-8DIO4M1-G20-IO

Motor Control Module with Extended Process Data

Manual

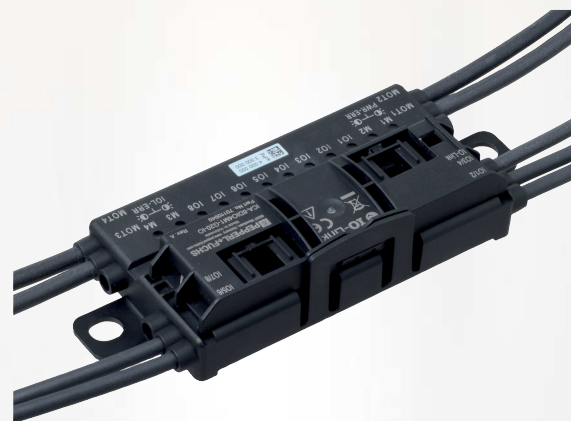

IO-Link

Your automation, our passion.

PEPPERL+FUCHS

With regard to the supply of products, the current issue of the following document is applicable: The General Terms of Delivery for Products and Services of the Electrical Industry, published by the Central Association of the Electrical Industry (Zentralverband Elektrotechnik und Elektroindustrie (ZVEI) e.V.) in its most recent version as well as the supplementary clause: "Expanded reservation of proprietorship"

Worldwide

Pepperl+Fuchs Group
Lilienthalstr. 200
68307 Mannheim
Germany
Phone: +49 621 776 - 0
E-mail: info@de.pepperl-fuchs.com

North American Headquarters

Pepperl+Fuchs Inc.
1600 Enterprise Parkway
Twinsburg, Ohio 44087
USA
Phone: +1 330 425-3555
E-mail: sales@us.pepperl-fuchs.com

Asia Headquarters

Pepperl+Fuchs Pte. Ltd.
P+F Building
18 Ayer Rajah Crescent
Singapore 139942
Phone: +65 6779-9091
E-mail: sales@sg.pepperl-fuchs.com
<https://www.pepperl-fuchs.com>

1	Introduction.....	5
1.1	Content of this Document.....	5
1.2	Target Group, Personnel	5
1.3	Symbols Used	5
1.4	General Safety Information.....	6
1.5	Konformitätserklärung	7
2	Product Description	8
2.1	Use and Application	8
2.2	Housing.....	10
2.3	LED Indicators	10
2.4	Interfaces and Connections	12
2.5	IO-Link Interface Properties	13
2.6	Braking Energy Power Feedback	13
3	Installation.....	14
3.1	Storage and Transportation	14
3.2	Unpacking	14
3.3	Mounting.....	14
3.4	Connecting the Auxiliary Current Flat Cable	14
3.5	Connecting Motors and Sensors	17
4	IO-Link Process Data.....	18
4.1	Input Process Data Structure	18
4.2	Output Process Data Structure	19
5	IO-Link Parameters.....	22
5.1	Device-Specific Operating/Configuration Parameters.....	22
5.2	Device Parameters.....	27
5.3	Standard Configuration Parameters.....	27
5.4	Specific Device Information.....	28
5.5	Operating Monitor.....	28
5.6	Diagnostics	29
5.7	Device-Specific Commands.....	32
6	Repair and Servicing	34

7	Appendix.....	35
7.1	Event Codes	35
7.2	Error Codes	36
7.3	ASCII table	37

1 Introduction

1.1 Content of this Document

This document contains information required to use the product in the relevant phases of the product life cycle. This may include information on the following:

- Product identification
- Delivery, transport, and storage
- Mounting and installation
- Commissioning and operation
- Maintenance and repair
- Troubleshooting
- Dismounting
- Disposal



Note

For full information on the product, refer to the further documentation on the Internet at www.pepperl-fuchs.com.

The documentation comprises the following parts:

- This document
- Datasheet

In addition, the documentation may comprise the following parts, if applicable:

- EU-type examination certificate
- EU declaration of conformity
- Attestation of conformity
- Certificates
- Control drawings
- Instruction manual
- Other documents

1.2 Target Group, Personnel

Responsibility for planning, assembly, commissioning, operation, maintenance, and dismantling lies with the plant operator.

Only appropriately trained and qualified personnel may carry out mounting, installation, commissioning, operation, maintenance, and dismantling of the product. The personnel must have read and understood the instruction manual and the further documentation.

Prior to using the product make yourself familiar with it. Read the document carefully.

1.3 Symbols Used

This document contains symbols for the identification of warning messages and of informative messages.

Warning Messages

You will find warning messages, whenever dangers may arise from your actions. It is mandatory that you observe these warning messages for your personal safety and in order to avoid property damage.

Depending on the risk level, the warning messages are displayed in descending order as follows:



Danger!

This symbol indicates an imminent danger.

Non-observance will result in personal injury or death.



Warning!

This symbol indicates a possible fault or danger.

Non-observance may cause personal injury or serious property damage.



Caution!

This symbol indicates a possible fault.

Non-observance could interrupt the device and any connected systems and plants, or result in their complete failure.

Informative Symbols



Note

This symbol brings important information to your attention.



Action

This symbol indicates a paragraph with instructions. You are prompted to perform an action or a sequence of actions.

1.4 General Safety Information

Responsibility for planning, assembly, commissioning, operation, maintenance, and dismantling lies with the plant operator.

Installation and commissioning of all devices may be performed only by trained and qualified personnel.

It is dangerous for the user to carry out modifications and/or repairs and doing so will void the warranty and exclude the manufacturer from any liability. In the event of any serious errors, stop using the device. Secure the device against unintended operation. To have the device repaired, return it to your local Pepperl+Fuchs representative or your sales center.



Note

Disposal

Electronic waste is hazardous. When disposing of the equipment, observe the current statutory requirements in the respective country of use, as well as local regulations.

1.5 Declaration of Conformity

This product was developed and manufactured in line with the applicable European standards and directives.



Note

A declaration of conformity can be requested from the manufacturer.

The product manufacturer, Pepperl+Fuchs Group, 68307 Mannheim, Germany, has a certified quality assurance system that conforms to ISO 9001.



2 Product Description

2.1 Use and Application

General

The ICA-8DIO4M1-G20-IO* roller motor control module is an IO-Link connection module for controlling up to four 24 V DC roller motors. The module enables process-specific control of features including the following on the connected roller motors:

- Direction of rotation
- Speed
- Start and stop ramps

The module is ideally suited for implementing complex conveying tasks. The module is optimized for Interroll EC310 roller motors but can also be used for compatible DC motors, e.g., Rulmeca BL3.

Digital Inputs and Outputs

To be able to optimally control the roller motor rollers based on conditions in the field environment (e.g., switching signal of a light barrier), the module has 8 freely configurable digital inputs/outputs (PNP). The input characteristic of the inputs corresponds to type 3 in accordance with EN 61131-2. The outputs are resistant to short circuits and overloading.

The module and the digital inputs/outputs are supplied via IO-Link. Each sensor power supply can be loaded with 200 mA.

For details regarding connection, see chapter 3.5.

Counters

The module has a counter input for connecting an incremental rotary encoder. You can connect a single- or dual-input rotary encoder with a counting frequency of up to 10 kHz.

- A single-input rotary encoder is connected to IO1.
- A dual-input rotary encoder is connected to IO1 and IO2, and takes the direction of rotation into account.

Note

Inverting the input channels affects the counter. If the counting direction is to be reversed for a dual-input rotary encoder, one of the two inputs must be inverted.

The counting function has no effect on how inputs are processed at IO1 and IO2. The input filters are not taken into account for the counting function.

Roller Motors

The roller motors are supplied with power via an external auxiliary voltage. The auxiliary voltage is supplied to the roller motor control module via a flat cable.

- The permissible auxiliary voltage is 18 V to 30 V.
- The maximum continuous current load for each roller motor is 2.5 A.
- For each roller motor, a maximum current load of 5 A is permitted briefly (< 2 s).

If a roller motor is connected to a motor output, the output must be configured accordingly. The following statuses are transmitted via the process data:

- Roller motor fault
- Fusing
- Switching on and off



- Direction of rotation
- SpeedDifferent Functions Based on IODD¹
- Start/stop ramps¹



Tip

If a motor output is not configured for a roller motor, pin 2 of the corresponding output can be used as a digital power output, which is supplied from the auxiliary voltage PWR. A separate bit for controlling the power output is available in the process data.

The output at pin 2 is resistant to overloading and short circuits. The roller motor supply is protected by a fuse.

The speed is expressed as a percentage. The output voltage for controlling the roller motor speed is output between the configurable limits. The lower limit corresponds to 0 % of the maximum speed, the upper limit corresponds to 100 % of the maximum speed.

For details regarding connection, see chapter 3.5.

Braking Function

You can use the process data to activate a brake for each roller motor. An activated brake causes the analog velocity output to be lowered to 0 V after reaching the lower limit. For some roller motors, this is mandatory to activate the brake function. This setting has no effect on Interroll EC310 roller motors, as these roller motors always brake.

Start/Stop Ramps

The configurable ramp duration defines the time from stationary (0 %) to maximum speed (100 %), or from maximum speed to stationary. When the terminal velocity is lower, the ramp duration is shorter.

General IO-Link Information



IO-Link is a standardized point-to-point IO technology (IEC 61131-9) between an IO-Link master that controls communication and an IO-Link device that acquires or executes process values at the lowest sensor/actuator level. In addition to transmitting process data, IO-Link also provides access to detailed identification, diagnostic and parameter data of the respective IO-Link device.

IO-Link uses unshielded 3- or 5-wire cables with a maximum length of 20 meters between the IO-Link master and IO-Link device, and enables transfer rates of 4.8 kbit/s (COM1), 38.4 kbit/s (COM2), or 230.4 kbit/s (COM3). The IO-Link interface is backward compatible with the 24 V I/O signals specified in IEC 61131-2.

Different Functions Based on IODD

The module has two different process data structures - Standard (STD) and Extended (EXT). Which structure is used depends on the IO-Link device ID that is set. While the standard process data image assigns 8 bytes of input data and 6 bytes of output data, the extended process data image uses 8 bytes of input data and 18 bytes of output data. In addition to the functions of the standard process data image, the extended process data image enables control of the start/stop ramps and continuous, real-time adjustment of the roller motor speed via the process data.

1. Depending on the selected process data structure, see "Different Functions Based on IODD" on page 9

**Tip**

You can download the corresponding manual for each version from our website www.pepperl-fuchs.com.

For detailed information on the structure and assignment of the process data image, see chapter 4.

2.2**Housing**

The housing is made entirely of plastic, except for the hinge pins for the hinge cable guide.

The housing consists of the following main components:

- a mounting base with integrated electronics
- a folding guide cage as a cable guide for the AS-Interface flat cable

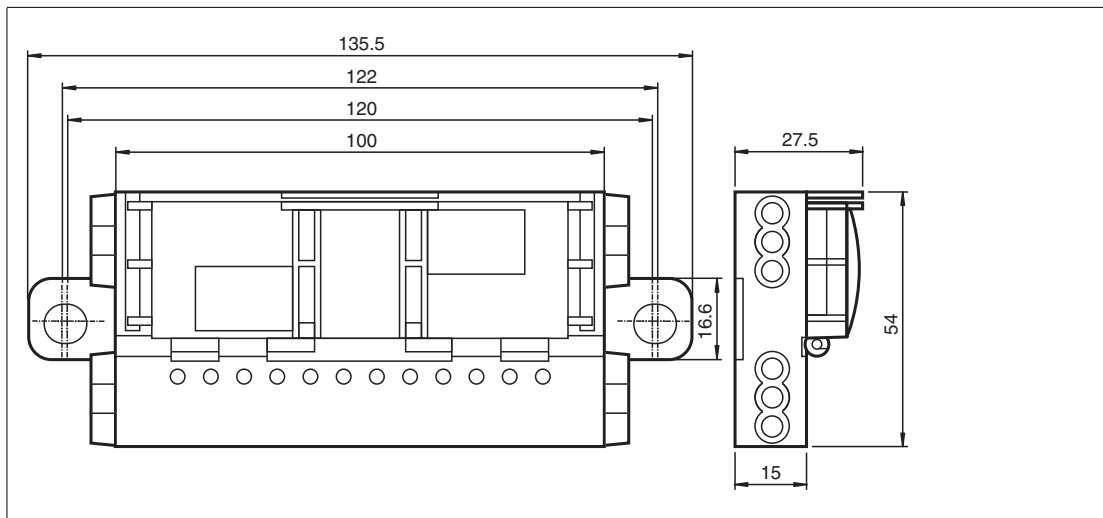

Figure 2.1 Housing dimensions

2.3**LED Indicators**

Figure 2.2 LED indicators

Note

The LEDs on the inputs and outputs indicate the physical state of the respective channel. You can find the invertible logical state of a channel in the process data.

LEDs IO1 – IO8

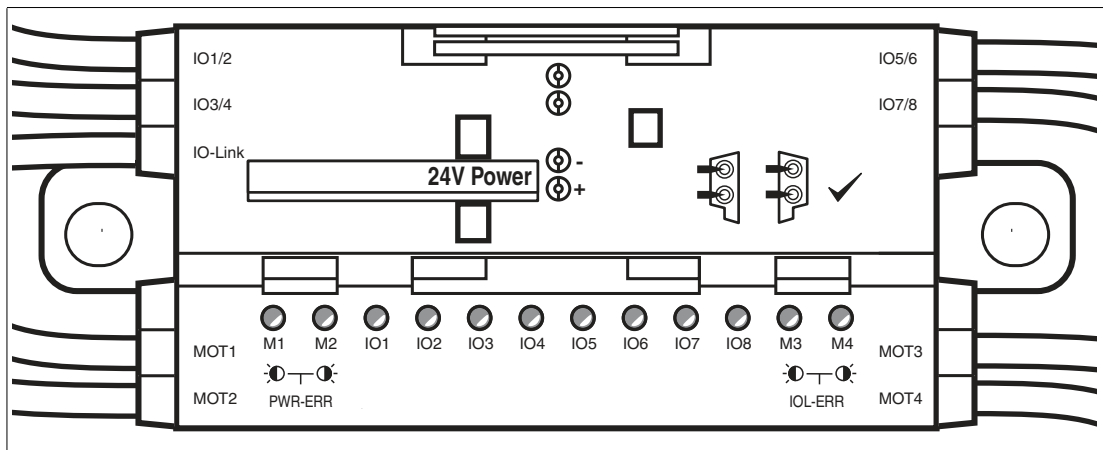
Status	Function
Off	Input/output not active
Yellow lit up	Input/output active
All LEDs flashing red ¹ Yellow unchanged	No communication with IO-Link master State of the input/output
Red lit up	Overload or short circuit of the output or supply
Red LEDs illuminating in sequence	No valid firmware or firmware update active

1. Long off, short on

LEDs M1 – M4

Status	Function
Off	Motor is not running/output is not active
Yellow	Motor is running/output active (high)
Red	Overload or short circuit at the output (also during motor operation)
Red flashing	Motor fault (only during motor operation)
Red/yellow flashing	Motor supply fuse faulty (only during motor operation)
MOT3 & MOT4 flashing red alternately	Motor controller is running, but no communication with IO-Link controller <ul style="list-style-type: none"> IO-Link supply not present or firmware update active PWR supply present
MOT1 & MOT2 flashing yellow alternately	IO-Link controller is running, no communication with motor controller <ul style="list-style-type: none"> IO-Link supply present PWR supply not present
MOT3 & MOT4 flashing red	No valid firmware in the motor controller Erroneous firmware update

**Note**

The LEDs MOT1, MOT2, and IO1 to IO8 are supplied from IO-Link; the LEDs MOT3 and MOT4 are supplied from PWR.

**Note**

When all LEDs are in the "off" state, a heartbeat (1.9 s off/0.1 s on) is output via all yellow motor LEDs to signal the general operational readiness of the module. The heartbeat always begins with a full "off" phase.

Flashing Pattern for Device Identification

In the field, a device can be identified by a flashing pattern. The flashing pattern is activated via parameter index (127). All LEDs flash in the following pattern:

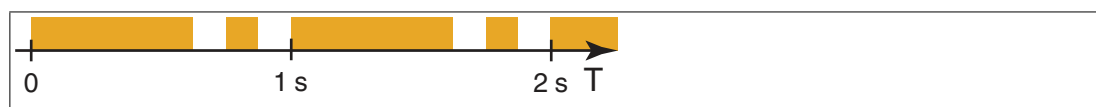

Figure 2.3 Flashing pattern for device identification







2.4 Interfaces and Connections

Flat Cable Specification

The motor control module is compatible with the AS-Interface standard cable in accordance with IEC 62026-2.

The following AS-Interface cable types are available with "UL Recognized" approval:

AS-Interface Cable Types with UL Approval

Pepperl+Fuchs Designation	Color	Sheathing/Wire Insulation Material	Cross Section	UL "Cable Style"	Approval
VAZ-FK-R-BK	Black	TPE/TPE	2 x 1.5 mm ²	2103	CE  c 
VAZ-FK-PUR-BK	Black	PUR(TMPU)/TPM	2 x 1.5 mm ²	20549	CE  c 
VAZ-FK-PUR-BK-2,5MM	Black	PUR	2 x 2.5 mm ²	20549 10493	CE  c 



Warning!

Observe the maximum permitted operating temperature of the cable !

The maximum permitted operating temperature of the AS-Interface flat cable connected to the module must be at least 80° C.

Input/Output Connections

The sensors and motors are connected to the motor control module via cables with round M8 connectors:

- Sensors: socket, 4-pin
- Motors: socket, 5-pin

Motor Supply from Auxiliary Voltage

The motors are supplied with power directly from the external auxiliary voltage PWR and this cannot be switched. The voltage is always present at contacts 1 and 3 of the 5-pin M8 connector.

Plug Assignment

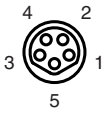
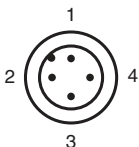
Connection For	Connector	Plug Type/Assignment
Inputs/outputs		<p>Input: LF004-GS1-A in accordance with IEC/EN 61076-2-104 M8, 4-pin, socket, union nut, A-coded</p> <p>Matching female connector: LM004-Gx1-A or similar</p> <p>1: V+ sensor supply 2: IO2, IO4, IO6, IO8 3: V- sensor supply 4: IO1, IO3, IO5, IO7</p>
Motor		<p>Motor: NF005-SS1-B in accordance with IEC/EN 61076-2-104 M8, 5-pin, socket, snap-locking, B-coded</p> <p>Matching female connector: NM005-Sx1-B or similar</p> <p>1: MOT+ motor supply 2: DIR/OUT direction of rotation 3: MOT- (=PWR-) motor supply 4: ERROR motor fault 5: SPEED velocity signal</p>
IO-Link		<p>IO-Link: LM type in accordance with EN 61076-2-101 M12, 4-pin, plug, screw-locking, A-coded</p> <p>Matching female connector: LF type or similar</p> <p>1: L+ 2: n.c. 3: L- 4: Q/C</p>

2.5 IO-Link Interface Properties

IO-Link protocol:	V1.1
COM mode:	COM 3
MIN cycle time:	2 ms
Process data length:	8 byte input data/18 byte output data
SIO mode:	Not supported
Port type:	Type A
Device ID:	0x0F0401
Vendor ID:	0x01

2.6 Braking Energy Power Feedback

The module can conduct electrical energy generated by the roller motor. Note the following maximum values.

Maximum current	4 A per motor
Maximum generated voltage	35 V DC

3 Installation

3.1 Storage and Transportation

Keep the original packaging. Always store and transport the device in the original packaging. Store the device in a clean and dry environment. The permitted ambient conditions must be considered, see datasheet.

3.2 Unpacking

Check the product for damage while unpacking. In the event of damage to the product, inform the post office or parcel service and notify the supplier.

Retain the original packaging in case the device must be stored or shipped again at a later date.

Should you have any questions, please contact Pepperl+Fuchs.

3.3 Mounting

Mount the device with both brackets (1) on a solid, continuous surface.

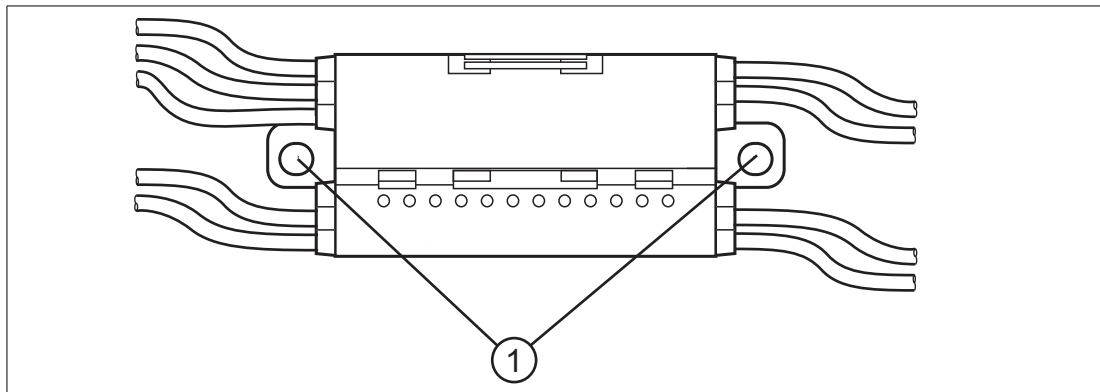

Figure 3.1 Mounting brackets (1)

3.4 Connecting the Auxiliary Current Flat Cable

The motor control module is connected to the PWR auxiliary voltage supply via the black flat cable. The permissible auxiliary voltage is 18 V to 30 V.

The contact between the motor control module and flat cables is established via two metal piercing pins and uses insulation piercing technology. The flat cable is routed through a cable guide with hinges. When closed, the cable guide is locked by a locking bracket and can be opened again without tools.

Flat-profile cables are narrow on top (with visibly offset profile edge) and wide underneath (profile edge not visible). The cable guide allows the flat cables to be inserted on either side, enabling flat cables that are already laid in cable ducts to be connected flexibly. However, it is important to ensure that the profile edge always points toward the motor control module. The mechanical reverse polarity protection prevents the cable guide from closing completely if the flat cable is inserted incorrectly.

Caution!

If a flat cable is inserted incorrectly, the motor control module will not work.

If the flat cable is inserted in the cable guide in the wrong direction, the voltage is inverted. The motor control module will not work. However, the internal electrical reverse polarity protection protects it from damage.



**Warning!**

Damage to contacts

Only connect or disconnect the module connections when the module is de-energized. Otherwise, the connections can be damaged.

**Connecting the Flat Cable on the Narrow Side**

The profile edge is visible from above.

1. Open the cable guide by pushing the locking bracket (1) slightly to the side.
2. Insert the black PWR flat cable with the profile edge (3) pointing toward the motor control module into the lower guide (see the "24V Power" marking on the module).
3. Make sure that the profile edges of the flat cable are beneath the corresponding reverse polarity protection (2).

**Tip**

Use the mounting aid VAZ-G20-MH to facilitate closing the cable guide.

4. Close the cable guide. It must engage securely in the locking bracket (1).

↳ The metal piercing pins touch the stranded wires in the flat cable.

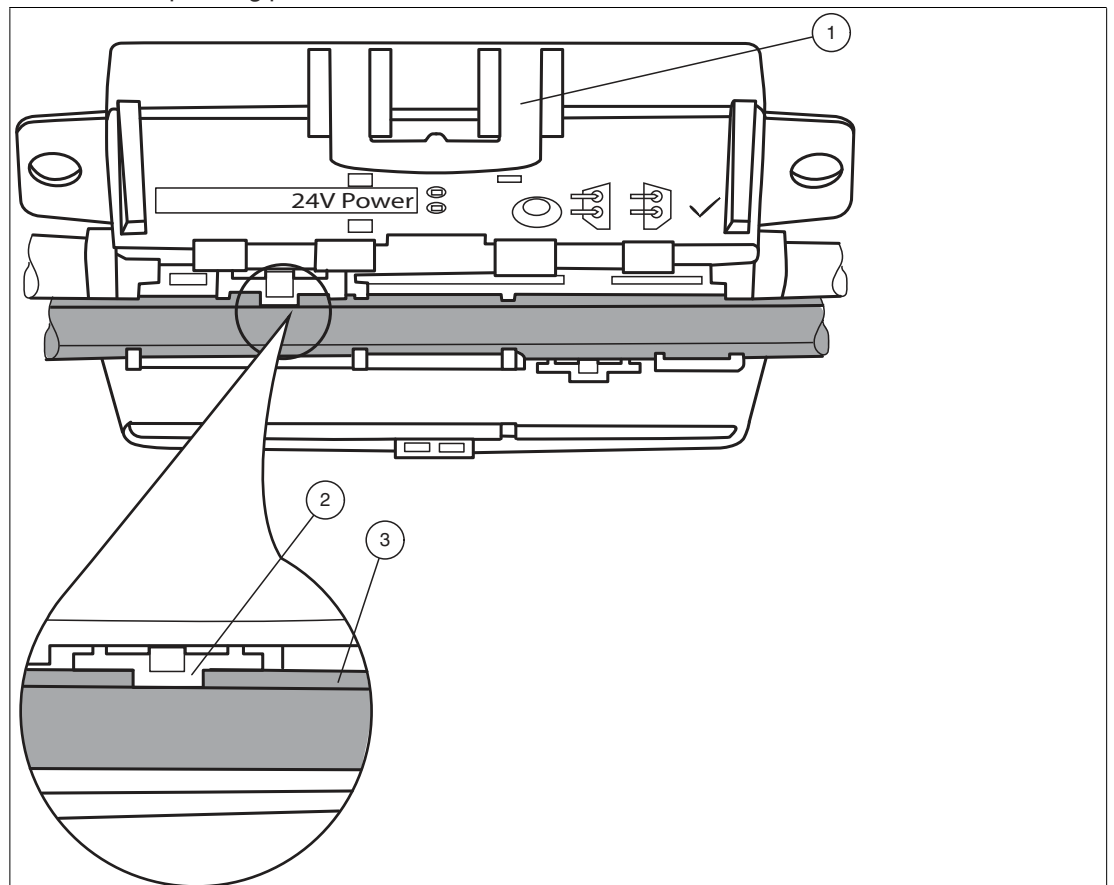

Figure 3.2 Connecting the flat cable on the narrow side



Connecting the Flat Cable on the Wide Side

The profile edge is not visible from above. For clarity in the figure below, a dotted line represents where the edge would be.

1. Open the cable guide by pushing the locking bracket (1) slightly to the side.
2. Insert the black PWR flat cable with the profile edge (2) pointing toward the motor control module into the lower guide (see the "24V Power" marking on the module).



Tip

Use the mounting aid VAZ-G20-MH to facilitate closing the cable guide.

3. Close the cable guide. It must engage securely in the locking bracket (1).

↳ The profile edge (2) of the flat cable is above the two reverse polarity protection diodes. The metal piercing pins touch the stranded wires in the flat cable.

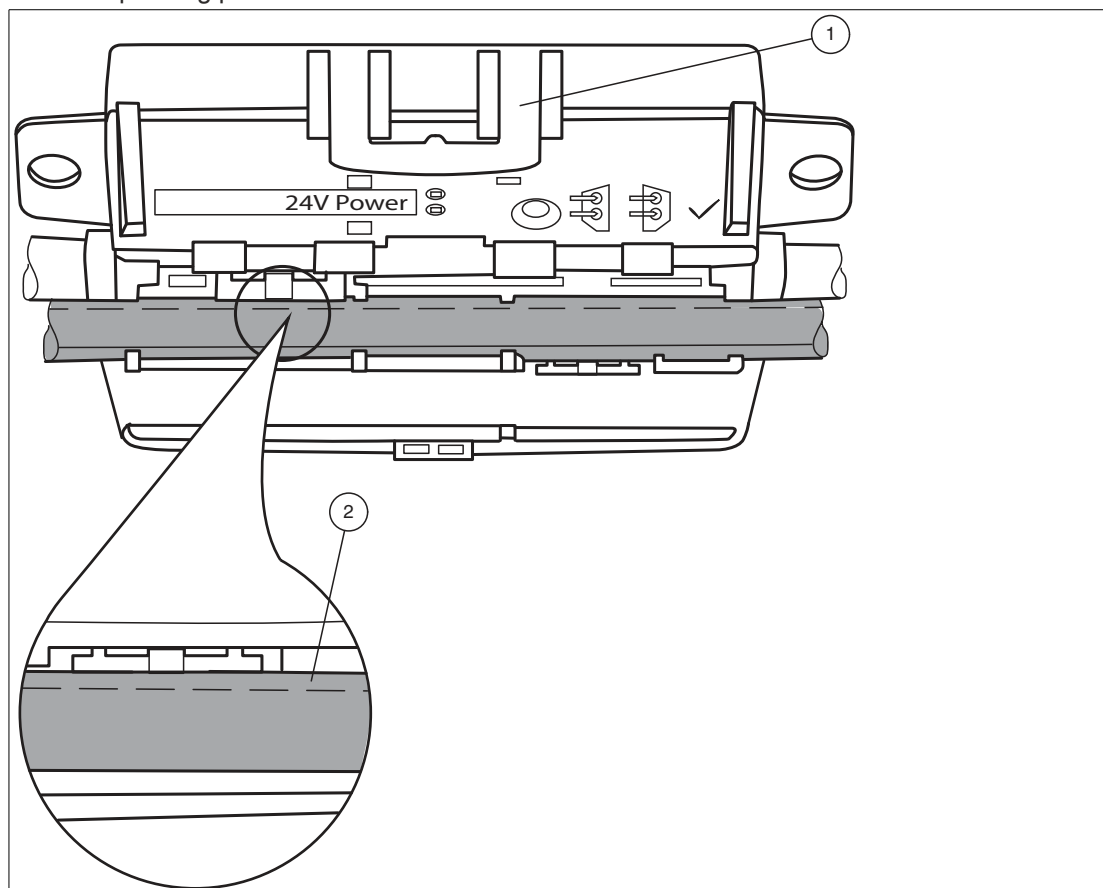

Figure 3.3 Connecting the flat cable on the wide side (profile edge shown as dotted line)

Flat Cable Inserted Incorrectly

The figure below shows an example where the flat cable has been inserted incorrectly. The profile edge (2) does not point toward the motor control module, so the flat cable is inserted with reverse polarity. The flat cable is curved and positioned above the reverse polarity protection (1), which means that the cable guide cannot be closed completely (mechanical reverse polarity protection).

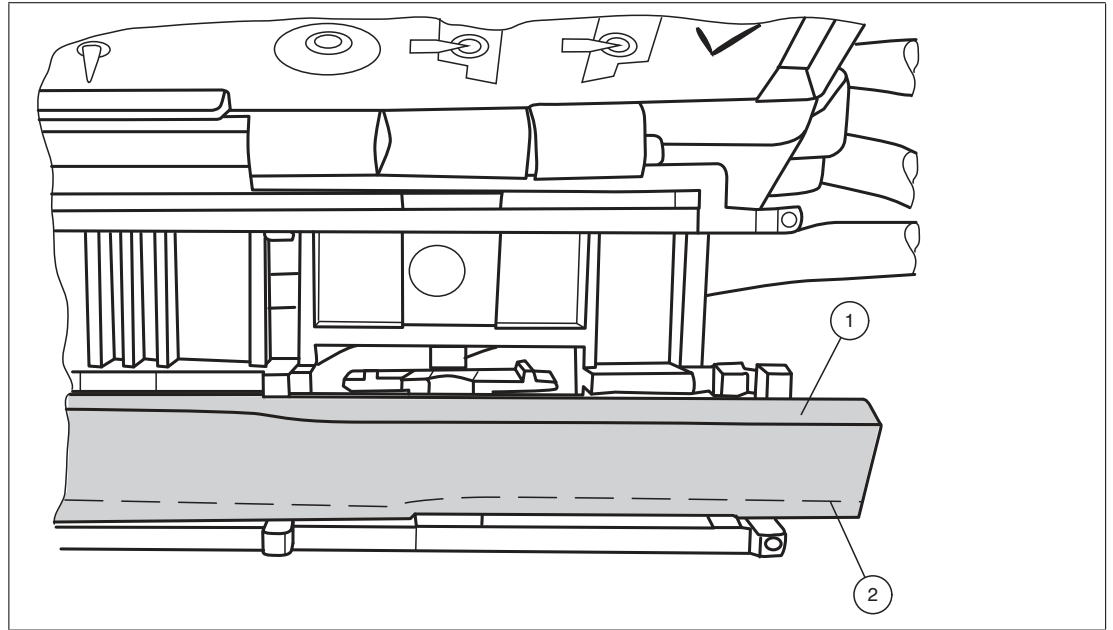

Figure 3.4 Flat cable inserted incorrectly (profile edge shown as dotted line)

3.5 Connecting Motors and Sensors

IO-Link, the inputs and outputs, and the motors are connected via standard round plug connectors.

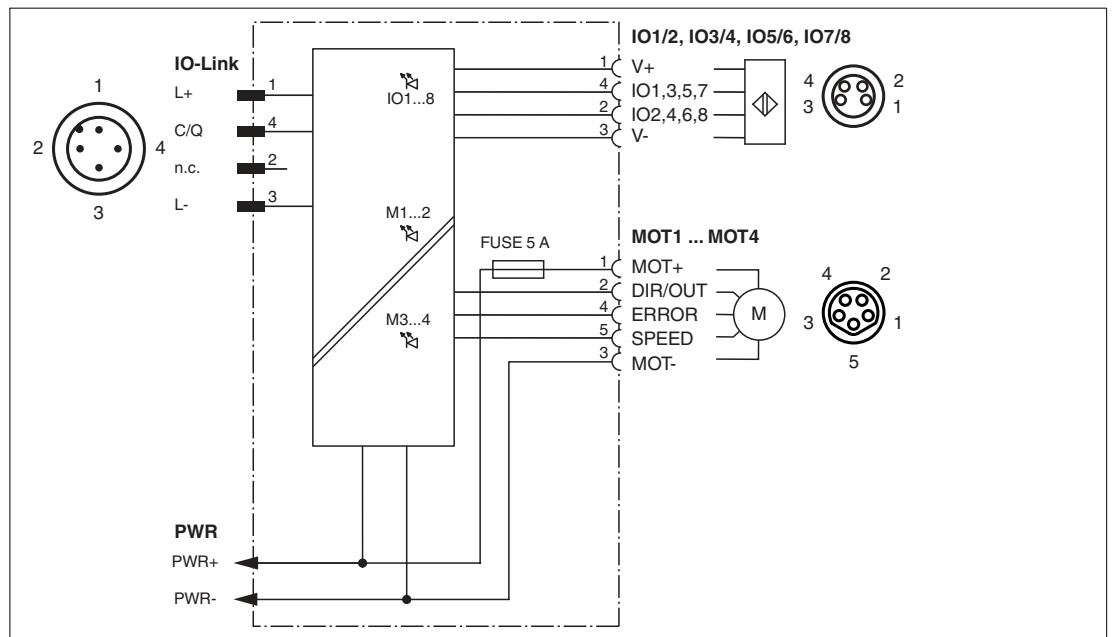

Figure 3.5 Connection wiring diagram for motors and sensors



Warning!

Damage to contacts

Only connect or disconnect the module connections when the module is de-energized. Otherwise, the connections can be damaged.

4 IO-Link Process Data

4.1 Input Process Data Structure

The process data input by the motor control module consists of 64 bits (8 byte). The following table provides an overview of the order and structure of the process data.

Name	Long Name	Data Type	Length	Bit Offset	Value	Function/Description
ISC - Input Signal Channel						
IN1	Input Signal 1	Boolean	1 bit	0	0 = low 1 = high	Status of input 1
IN2	Input Signal 2	Boolean	1 bit	1	0 = low 1 = high	Status of input 2
IN3	Input Signal 3	Boolean	1 bit	2	0 = low 1 = high	Status of input 3
IN4	Input Signal 4	Boolean	1 bit	3	0 = low 1 = high	Status of input 4
IN5	Input Signal 5	Boolean	1 bit	4	0 = low 1 = high	Status of input 5
IN6	Input Signal 6	Boolean	1 bit	5	0 = low 1 = high	Status of input 6
IN7	Input Signal 7	Boolean	1 bit	6	0 = low 1 = high	Status of input 7
IN8	Input Signal 8	Boolean	1 bit	7	0 = low 1 = high	Status of input 8
not assigned	-	-	1 byte	8	0 = low	
DSC - Diagnosis Signal Channel						
FUSEM1	Fuse Monitor Motor 1	Boolean	1 bit	16	0 = fuse OK 1 = fuse faulty	Fuse status of motor 1
FUSEM2	Fuse Monitor Motor 2	Boolean	1 bit	17	0 = fuse OK 1 = fuse faulty	Fuse status of motor 2
FUSEM3	Fuse Monitor Motor 3	Boolean	1 bit	18	0 = fuse OK 1 = fuse faulty	Fuse status of motor 3
FUSEM4	Fuse Monitor Motor 4	Boolean	1 bit	19	0 = fuse OK 1 = fuse faulty	Fuse status of motor 4
ERRM1	Error Monitor Motor 1	Boolean	1 bit	20	0 = no fault 1 = motor fault	Fault status of motor 1
ERRM2	Error Monitor Motor 2	Boolean	1 bit	21	0 = no fault 1 = motor fault	Fault status of motor 2
ERRM3	Error Monitor Motor 3	Boolean	1 bit	22	0 = no fault 1 = motor fault	Fault status of motor 3
ERRM4	Error Monitor Motor 4	Boolean	1 bit	23	0 = no fault 1 = motor fault	Fault status of motor 4

Name	Long Name	Data Type	Length	Bit Offset	Value	Function/Description
CNTZC	Counter Zero Crossing	Boolean	1 bit	24	0 = inactive 1 = active	Counter sign changed since the last reset
CNTOF	Counter Overflow	Boolean	1 bit	25	0 = inactive 1 = active	Counter overflow since the last reset
CNTUF	Counter Underflow	Boolean	1 bit	26	0 = inactive 1 = active	Counter underflow since the last reset
CNTREV	Counting Direction Change	Boolean	1 bit	27	0 = inactive 1 = active	Counting direction changed since the last reset
MCRDY	Motor Controller Ready	Boolean	1 bit	31	0 = inactive 1 = active	Motor controller section supplied with power and ready
SFD - Special Function Data						
Counter	Counter reading	Integer (32)	4 byte	32	- 214748364 8 (0x8000000 0) ... 214748364 7 (0x7FFFFFF FF)	Current counter reading

Table 4.1

4.2 Output Process Data Structure

The process data output by the motor control module consists of 144 bits (18 byte). The following table provides an overview of the order and structure of the process data.

Name	Long name	Data Type	Length	Bit Offset	Value	Function/Description
OCC - Output Control Channel						
OUT1	Output Signal 1	Boolean	1 bit	0	0 = low 1 = high	Sets digital output 1
OUT2	Output Signal 2	Boolean	1 bit	1	0 = low 1 = high	Sets digital output 2
OUT3	Output Signal 3	Boolean	1 bit	2	0 = low 1 = high	Sets digital output 3
OUT4	Output Signal 4	Boolean	1 bit	3	0 = low 1 = high	Sets digital output 4
OUT5	Output Signal 5	Boolean	1 bit	4	0 = low 1 = high	Sets digital output 5
OUT6	Output Signal 6	Boolean	1 bit	5	0 = low 1 = high	Sets digital output 6
OUT7	Output Signal 7	Boolean	1 bit	6	0 = low 1 = high	Sets digital output 7
OUT8	Output Signal 8	Boolean	1 bit	7	0 = low 1 = high	Sets digital output 8
SFC - Special Function Control						
CNTRES	Counter Reset	Boolean	1 bit	8	0 -> 1 = reset	Resets the counter value to 0

Name	Long name	Data Type	Length	Bit Offset	Value	Function/Description
CNTEN	Counter Enable	Boolean	1 bit	9	0 = deactivated 1 = activated	Enables the counter operation
CNTDIR	Counter Direction	Boolean	1 bit	10	0 = up 1 = down	Sets the direction of the counter
CNTRZC	Counter Reset Zero Crossing	Boolean	1 bit	11	0 -> 1 = reset	Resets the counter zero-crossing flag
CNTROF	Counter Reset Overflow	Boolean	1 bit	12	0 -> 1 = reset	Resets the counter overflow flag.
CNTRUF	Counter Reset Underflow	Boolean	1 bit	13	0 -> 1 = reset	Resets the counter underflow flag.
CNTRREV	Counter Reset Direction Change	Boolean	1 bit	14	0 -> 1 = reset	Resets the counter direction change flag.
CNTPRE	Counter Preset	Boolean	1 bit	15	0 -> 1 = reset	Sets the counter to the configured preset value
MCC - Motor Control Channel 1						
RUNC	Run Motor Control	Boolean	1 bit	16	0 = off 1 = on	Switches motor 1 on/off
DIRC	Direction Control	Boolean	1 bit	17	0 = left 1 = right	Sets the direction of motor rotation on motor 1 to left/right
BRKC	Brake Control	Boolean	1 bit	18	0 = inactive 1 = active	Sets the motor brake
not assigned	-	-	4 bits	19	0 = low	
POUTC	Power Output Control	Boolean	1 bit	23	0 = low 1 = high	Sets the digital output (pin 2) on motor channel 1, if configured
SPEED	Speed Value	Integer (8)	1 byte	24	0 ... 100	Sets the speed of motor 1 to the specified percentage
RAMP-DWN	Ramp Down Value	Integer (8)	1 byte	32	0 ... 255	Sets the ramp down time on motor 1 to a value in 20 ms increments
RAMPUP	Ramp Up Value	Integer (8)	1 byte	40	0 ... 255	Sets the ramp up time on motor 1 to a value in 20 ms increments
MCC - Motor Control Channel 2						
RUNC	Run Motor Control	Boolean	1 bit	48	0 = off 1 = on	Switches motor 2 on/off
DIRC	Direction Control	Boolean	1 bit	49	0 = left 1 = right	Sets the direction of motor rotation on motor 2 to left/right
BRKC	Brake Control	Boolean	1 bit	50	0 = inactive 1 = active	Sets the motor brake
not assigned	-	-	4 bits	51	0 = low	
POUTC	Power Output Control	Boolean	1 bit	55	0 = low 1 = high	Sets the digital output (pin 2) on motor channel 2, if configured

Name	Long name	Data Type	Length	Bit Offset	Value	Function/Description
SPEED	Speed Value	Integer (8)	1 byte	56	0 ... 100	Sets the speed of motor 2 to the specified percentage.
RAMP-DWN	Ramp Down Value	Integer (8)	1 byte	64	0 ... 255	Sets the ramp down time on motor 2 to a value in 20 ms increments.
RAMPUP	Ramp Up Value	Integer (8)	1 byte	72	0 ... 255	Sets the ramp up time on motor 2 to a value in 20 ms increments.
MCC - Motor Control Channel 3						
RUNC	Run Motor Control	Boolean	1 bit	80	0 = off 1 = on	Switches motor 3 on/off.
DIRC	Direction Control	Boolean	1 bit	81	0 = left 1 = right	Sets the direction of motor rotation on motor 3 to left/right.
BRKC	Brake Control	Boolean	1 bit	82	0 = inactive 1 = active	Sets the motor brake
not assigned	-	-	4 bits	83	0 = low	
POUTC	Power Output Control	Boolean	1 bit	87	0 = low 1 = high	Sets the digital output (pin 2) on motor channel 3, if configured
SPEED	Speed Value	Integer (8)	1 byte	88	0 ... 100	Sets the speed of motor 3 to the specified percentage.
RAMP-DWN	Ramp Down Value	Integer (8)	1 byte	96	0 ... 255	Sets the ramp down time on motor 3 to a value in 20 ms increments.
RAMPUP	Ramp Up Value	Integer (8)	1 byte	104	0 ... 255	Sets the ramp up time on motor 3 to a value in 20 ms increments.
MCC - Motor Control Channel 4						
RUNC	Run Motor Control	Boolean	1 bit	112	0 = off 1 = on	Switches motor 4 on/off.
DIRC	Direction Control	Boolean	1 bit	113	0 = left 1 = right	Sets the direction of motor rotation on motor 4 to left/right.
BRKC	Brake Control	Boolean	1 bit	114	0 = inactive 1 = active	Sets the motor brake
not assigned	-	-	4 bits	115	0 = low	
POUTC	Power Output Control	Boolean	1 bit	119	0 = low 1 = high	Sets the digital output (pin 2) on motor channel 4, if configured
SPEED	Speed Value	Integer (8)	1 byte	120	0 ... 100	Sets the speed of motor 4 to the specified percentage.
RAMP-DWN	Ramp Down Value	Integer (8)	1 byte	128	0 ... 255	Sets the ramp down time on motor 4 to a value in 20 ms increments.
RAMPUP	Ramp Up Value	Integer (8)	1 byte	136	0 ... 255	Sets the ramp up time on motor 4 to a value in 20 ms increments.

Table 4.2

5 IO-Link Parameters

5.1 Device-Specific Operating/Configuration Parameters

Index/ .sub	Parameter	Access	Data Type	Length	Bit Off- set	Value Range	Def ault	Description
Motor 1 Control Configuration								
72 (0x48)	MCC1 Con- fig	r/w	Record (1)	5 byte				Configuration parameters of the motor control channel MCC1.
.1	Output mode		UInteger (8)		32	0: digital output 1: motor control	0	Output mode as motor control or digital output.
.2	Output logic		UInteger (8)		24	0: high active - not inverted 1: low active - inverted	0	Output logic for the digital output.
.3	Error logic		UInteger (8)		16	0: high active - not inverted 1: low active - inverted	0	Logic of the fault signal input.
.4	Speed range min		UInteger (8)		8	0 ... 136	20	Voltage level for the minimum speed in 0.1 V increments.
.5	Speed range max		UInteger (8)		0	0 ... 136	100	Voltage level for maximum speed in 0.1 V increments.
Motor 2 Control Configuration								
73 (0x49)	MCC2 Con- fig	r/w	Record (1)	5 byte				Configuration parameters of the motor control channel MCC2.
.1	Output mode		UInteger (8)		32	0: digital output 1: motor control	0	Output mode as motor control or digital output.
.2	Output logic		UInteger (8)		24	0: high active - not inverted 1: low active - inverted	0	Output logic for the digital output.
.3	Error logic		UInteger (8)		16	0: high active - not inverted 1: low active - inverted	0	Logic of the fault signal input.
.4	Speed range min		UInteger (8)		8	0 ... 136	20	Voltage level for the minimum speed in 0.1 V increments.
.5	Speed range max		UInteger (8)		0	0 ... 136	100	Voltage level for maximum speed in 0.1 V increments.
Motor 3 Control Configuration								
74 (0x4A)	MCC3 Con- fig	r/w	Record (1)	5 byte				Configuration parameters of the motor control channel MCC3.
.1	Output mode		UInteger (8)		32	0: digital output 1: motor control	0	Output mode as motor control or digital output.
.2	Output logic		UInteger (8)		24	0: high active - not inverted 1: low active - inverted	0	Output logic for the digital output.

Index/ .sub	Parameter	Access	Data Type	Length	Bit Offset	Value Range	Default	Description
.3	Error logic		UInteger (8)		16	0: high active - not inverted 1: low active - inverted	0	Logic of the fault signal input.
.4	Speed range min		UInteger (8)		8	0 ... 136	20	Voltage level for the minimum speed in 0.1 V increments.
.5	Speed range max		UInteger (8)		0	0 ... 136	100	Voltage level for maximum speed in 0.1 V increments.
Motor 4 Control Configuration								
75 (0x4B)	MCC4 Con- fig	r/w	Record (1)	5 byte				Configuration parameters of the motor control channel MCC4.
.1	Output mode		UInteger (8)		32	0: digital output 1: motor con- trol	0	Output mode as motor control or digital output.
.2	Output logic		UInteger (8)		24	0: high active - not inverted 1: low active - inverted	0	Output logic for the digital output.
.3	Error logic		UInteger (8)		16	0: high active - not inverted 1: low active - inverted	0	Logic of the fault signal input.
.4	Speed range min		UInteger (8)		8	0 ... 136	20	Voltage level for the minimum speed in 0.1 V increments.
.5	Speed range max		UInteger (8)		0	0 ... 136	100	Voltage level for maximum speed in 0.1 V increments.
Motor 1 Configuration of the Maintenance Requirement								
80 (0x50)	MCC1 Con- figMReq	r/w	Record (1)	12 byte				Configuration parameters for the maintenance requirement prop- erties of the motor control chan- nel MCC1
.1	Runtime interval		UInteger (32)		64	0: deactivated 1 ... 1000000	0	Motor runtime interval for a main- tenance requirement warning in hours
.2	Run cycle interval		UInteger (32)		32	0: deactivated 1 ... 4294967295	0	Motor run cycle interval for a maintenance requirement warn- ing
.3	Error count interval		UInteger (32)		0	0: deactivated 1 ... 4294967295	0	Engine fault count interval for a maintenance requirement warn- ing
Motor 2 Configuration of the Maintenance Requirement								
81 (0x51)	MCC2 Con- figMReq	r/w	Record (1)	12 byte				Configuration parameters for the maintenance requirement prop- erties of the motor control chan- nel MCC2
.1	Runtime interval		UInteger (32)		64	0: deactivated 1 ... 1000000	0	Motor runtime interval for a main- tenance requirement warning in hours
.2	Run cycle interval		UInteger (32)		32	0: deactivated 1 ... 4294967295	0	Motor run cycle interval for a maintenance requirement warn- ing

Index/ .sub	Parameter	Access	Data Type	Length	Bit Off- set	Value Range	Def ault	Description
.3	Error count interval		UInteger (32)		0	0: deactivated 1 ... 4294967295	0	Engine fault count interval for a maintenance requirement warning
Motor 3 Configuration of the Maintenance Requirement								
82 (0x52)	MCC3 ConfigMReq	r/w	Record (1)	12 byte				Configuration parameters for the maintenance requirement properties of the motor control channel MCC3
.1	Runtime interval		UInteger (32)		64	0: deactivated 1 ... 1000000	0	Motor runtime interval for a maintenance requirement warning in hours
.2	Run cycle interval		UInteger (32)		32	0: deactivated 1 ... 4294967295	0	Motor run cycle interval for a maintenance requirement warning
.3	Error count interval		UInteger (32)		0	0: deactivated 1 ... 4294967295	0	Engine fault count interval for a maintenance requirement warning
Motor 4 Configuration of the Maintenance Requirement								
83 (0x53)	MCC4 ConfigMReq	r/w	Record (1)	12 byte				Configuration parameters for the maintenance requirement properties of the motor control channel MCC4
.1	Runtime interval		UInteger (32)		64	0: deactivated 1 ... 1000000	0	Motor runtime interval for a maintenance requirement warning in hours
.2	Run cycle interval		UInteger (32)		32	0: deactivated 1 ... 4294967295	0	Motor run cycle interval for a maintenance requirement warning
.3	Error count interval		UInteger (32)		0	0: deactivated 1 ... 4294967295	0	Engine fault count interval for a maintenance requirement warning
IO Port 1 Configuration								
88 (0x58)	IOC1 Config	r/w	Record (1)	3 byte				Configuration of IO channel 1.
.1	I/O mode		UInteger (8)		16	0: digital input 1: digital output	0	I/O mode as digital input or digital output.
.2	I/O logic		UInteger (8)		8	0: high active - not inverted 1: low active - inverted	0	Logic for the digital input/output.
.3	Input filter		UInteger (8)		0	0: deactivated 1: 0.5 ms 2: 1.0 ms 3: 2.0 ms 4: 3.0 ms 5: 5.0 ms	0	Filter time for digital input signals.
IO Port 2 Configuration								
89 (0x59)	IOC2 Config	r/w	Record (1)	3 byte				Configuration of IO channel 2.
.1	I/O mode		UInteger (8)		16	0: digital input 1: digital output	0	I/O mode as digital input or digital output.

Index/ .sub	Parameter	Access	Data Type	Length	Bit Off- set	Value Range	Def ault	Description
.2	I/O logic		UInteger (8)		8	0: high active - not inverted 1: low active - inverted	0	Logic for the digital input/output.
.3	Input filter		UInteger (8)		0	0: deactivated 1: 0.5 ms 2: 1.0 ms 3: 2.0 ms 4: 3.0 ms 5: 5.0 ms	0	Filter time for digital input signals.
IO Port 3 Configuration								
90 (0x5A)	IOC3 Con- fig	r/w	Record (1)	3 byte				Configuration of IO channel 3.
.1	I/O mode		UInteger (8)		16	0: digital input 1: digital output	0	I/O mode as digital input or digital output.
.2	I/O logic		UInteger (8)		8	0: high active - not inverted 1: low active - inverted	0	Logic for the digital input/output.
.3	Input filter		UInteger (8)		0	0: deactivated 1: 0.5 ms 2: 1.0 ms 3: 2.0 ms 4: 3.0 ms 5: 5.0 ms	0	Filter time for digital input signals.
IO Port 4 Configuration								
91 (0x5B)	IOC4 Con- fig	r/w	Record (1)	3 byte				Configuration of IO channel 4.
.1	I/O mode		UInteger (8)		16	0: digital input 1: digital output	0	I/O mode as digital input or digital output.
.2	I/O logic		UInteger (8)		8	0: high active - not inverted 1: low active - inverted	0	Logic for the digital input/output.
.3	Input filter		UInteger (8)		0	0: deactivated 1: 0.5 ms 2: 1.0 ms 3: 2.0 ms 4: 3.0 ms 5: 5.0 ms	0	Filter time for digital input signals.
IO Port 5 Configuration								
92 (0x5C)	IOC5 Con- fig	r/w	Record (1)	3 byte				Configuration of IO channel 5.
.1	I/O mode		UInteger (8)		16	0: digital input 1: digital output	0	I/O mode as digital input or digital output.
.2	I/O logic		UInteger (8)		8	0: high active - not inverted 1: low active - inverted	0	Logic for the digital input/output.

Index/ .sub	Parameter	Access	Data Type	Length	Bit Off- set	Value Range	Def ault	Description
.3	Input filter		UInteger (8)		0	0: deactivated 1: 0.5 ms 2: 1.0 ms 3: 2.0 ms 4: 3.0 ms 5: 5.0 ms	0	Filter time for digital input signals.
IO Port 6 Configuration								
93 (0x5D)	IOC6 Con- fig	r/w	Record (1)	3 byte				Configuration of IO channel 6.
.1	I/O mode		UInteger (8)		16	0: digital input 1: digital output	0	I/O mode as digital input or digital output.
.2	I/O logic		UInteger (8)		8	0: high active - not inverted 1: low active - inverted	0	Logic for the digital input/output.
.3	Input filter		UInteger (8)		0	0: deactivated 1: 0.5 ms 2: 1.0 ms 3: 2.0 ms 4: 3.0 ms 5: 5.0 ms	0	Filter time for digital input signals.
IO Port 7 Configuration								
94 (0x5E)	IOC7 Con- fig	r/w	Record (1)	3 byte				Configuration of IO channel 7.
.1	I/O mode		UInteger (8)		16	0: digital input 1: digital output	0	I/O mode as digital input or digital output.
.2	I/O logic		UInteger (8)		8	0: high active - not inverted 1: low active - inverted	0	Logic for the digital input/output.
.3	Input filter		UInteger (8)		0	0: deactivated 1: 0.5 ms 2: 1.0 ms 3: 2.0 ms 4: 3.0 ms 5: 5.0 ms	0	Filter time for digital input signals.
IO Port 8 Configuration								
95 (0x5F)	IOC8 Con- fig	r/w	Record (1)	3 byte				Configuration of IO channel 8.
.1	I/O mode		UInteger (8)		16	0: digital input 1: digital output	0	I/O mode as digital input or digital output.
.2	I/O logic		UInteger (8)		8	0: high active - not inverted 1: low active - inverted	0	Logic for the digital input/output.
.3	Input filter		UInteger (8)		0	0: deactivated 1: 0.5 ms 2: 1.0 ms 3: 2.0 ms 4: 3.0 ms 5: 5.0 ms	0	Filter time for digital input signals.

Table 5.1

5.2 Device Parameters

Index/ .sub	Parameter	Access	Data Type	Length	Bit Off- set	Value Range	Def ault	Description
Module Configuration								
96 (0x60)	Module Config	r/w	Record (1)	6 byte				Configuration of the module
.1	Encoder input mode		UInteger (8)		40	0 = single-input rotary encoder 1 = dual-input rotary encoder	0	Configures the connected rotary encoder
.2	Compensa- tion		UInteger (8)		32	0: on 1: off	0	Activates the speed compensa- tion for all motor connections
.3	Counter preset value		Integer (32)		0	-2147483648 (0x80000000) to 2147483647 (0x7FFFFFFF)	0	Preset value of the counter

Table 5.2

5.3 Standard Configuration Parameters

Index/ .sub	Parameter	Access	Data Type	Length	Bit Off- set	Value Range	Def ault	Description
Event Configuration								
120 (0x78)	Event Con- fig	r/w	Record (1)	2 byte				Describes the configuration of an event, see "Event Codes"
.1	Warning (mr): Motor mainte- nance diag- nosis		Boolean		0	0: deactivated 1: activated	0	Event code 0x8D01.
.2	Warning (os): Motor power fail		Boolean		1	0: deactivated 1: activated	0	Event code 0x8D50.
.3	Warning (os): Power output over- load		Boolean		2	0: deactivated 1: activated	0	Event code 0x8D51.
.4	Warning (os): I/O port over- load		Boolean		3	0: deactivated 1: activated	0	Event code 0x8D52.
	Reserved		Boolean		4 – 15	0	0	
Indication Configuration								
127 (0x7F)	Indication Control	r/w	Record (1)	1 byte				

Index/.sub	Parameter	Access	Data Type	Length	Bit Offset	Value Range	Default	Description
.1	Locator Indication		Boolean		0	0: deactivated - normal indication 1: activated - location-dependent indication	0	
.2 – .8	Reserved		Boolean			0: deactivated		

Table 5.3

5.4 Specific Device Information

Index/.sub	Parameter	Access	Data Type	Length	Bit Offset	Value Range	Default	Description
191 (0xBF)	Unique Product ID	r	Character	128 byte				Specific device identification in accordance with DIN SPEC 91406

Table 5.4

5.5 Operating Monitor

Index/.sub	Parameter	Access	Data Type	Length	Bit Offset	Value Range	Default	Description
Motor 1 Operating Monitor								
216 (0xD8)	MCC1 Operating Mon	r	Record (1)	12 byte				Status of motor channel 1
.1	Runtime		UInteger (32)		64	0 ... 1073741823 (no overflow)	0	Runtime since the last maintenance reset for this motor channel in hours ¹
.2	Run cycles		UInteger (32)		32	0 ... 4294967295 (no overflow)	0	Run cycles since the last maintenance reset for this motor channel, stored every 15 min
.2	Error count		UInteger (32)		0	0 ... 4294967295 (no overflow)	0	Number of errors since the last maintenance reset for this motor channel, stored every 15 min
Motor 2 Operating Monitor								
217 (0xD9)	MCC2 Operating Mon	r	Record (1)	12 byte				Status of motor channel 2
.1	Runtime		UInteger (32)		64	0 ... 1073741823 (no overflow)	0	Runtime since the last maintenance reset for this motor channel in hours ¹ <Default – ¹ Font>
.2	Run cycles		UInteger (32)		32	0 ... 4294967295 (no overflow)	0	Run cycles since the last maintenance reset for this motor channel, stored every 15 min
.2	Error count		UInteger (32)		0	0 ... 4294967295 (no overflow)	0	Number of errors since the last maintenance reset for this motor channel, stored every 15 min

2021-02

Index/ .sub	Parameter	Access	Data Type	Length	Bit Offset	Value Range	Default	Description
Motor 3 Operating Monitor								
218 (0xDA)	MCC3 Operating Mon	r	Record (1)	12 byte				Status of motor channel 3
.1	Runtime		UInteger (32)		64	0 ... 1073741823 (no overflow)	0	Runtime since the last maintenance reset for this motor channel in hours ¹ <Default -1 Font>
.2	Run cycles		UInteger (32)		32	0 ... 4294967295 (no overflow)	0	Run cycles since the last maintenance reset for this motor channel, stored every 15 min
.2	Error count		UInteger (32)		0	0 ... 4294967295 (no overflow)	0	Number of errors since the last maintenance reset for this motor channel, stored every 15 min
Motor 4 Operating Monitor								
219 (0xDB)	MCC4 Operating Mon	r	Record (1)	12 byte				Status of motor channel 4
.1	Runtime		UInteger (32)		64	0 ... 1073741823 (no overflow)	0	Runtime since the last maintenance reset for this motor channel in hours ¹ <Default -1 Font>
.2	Run cycles		UInteger (32)		32	0 ... 4294967295 (no overflow)	0	Run cycles since the last maintenance reset for this motor channel, stored every 15 min
.2	Error count		UInteger (32)		0	0 ... 4294967295 (no overflow)	0	Number of errors since the last maintenance reset for this motor channel, stored every 15 min

Table 5.5

1. Internal resolution is milliseconds, stored every 15 min

5.6 Diagnostics

Index/ .sub	Parameter	Access	Data Type	Length	Bit Offset	Value Range	Default	Description
224 (0xE0)	Operating hours	r	UInteger (32)	4 byte		0 ... 1073741823		Operating hours of the module in hours ¹
225 (0xE1)	Temperature Indicator	r	Integer (8)	1 byte		0: normal 1: critically high 2: excess temperature 3: critically low 4: insufficient temperature		Ambient temperature in relation to the specified operating temperature range.
226 (0xE2)	Temperature Monitor	r	Record (1)	10 byte				Temperature measurements, insufficient and exceeding temperatures
.1	OVT Operating Hours		UInteger (32)		48	0 ... 4294967295		Total operating hours above the specified operating temperature range in hours

Index/ .sub	Parameter	Access	Data Type	Length	Bit Off- set	Value Range	Default	Description
.2	OVT Exceeded Counter		UInteger (16)		32	0 ... 65535		Number of occurrences of excess temperature. Increases when the OVT threshold is exceeded ¹ <Default - ¹ Font>
.3	Max. Temperature		Integer (8)		24	-40 ... +125		Maximum recorded temperature in °C
.4	Min. Temperature		Integer (8)		16	-40 ... +125		Minimum recorded temperature in °C
.5	Operating Temperature - Control		Integer (8)		8	-40 ... +125		Current internal temperature in the motor control module in °C
6	Operating Temperature - Communication		Integer (8)		0	-40 ... +125		Current internal temperature in communication in °C
Diagnostics of the Motor Maintenance								
228 (0xE4)	MCC Diag MReq	r	Record (1)	4 byte				Servicing of the motor channels
.1	M1 - runtime alarm		Boolean		0	0: inactive 1: active	0	Indicates that the configured runtime maintenance interval is exceeded on this motor channel
2	M1 - run cycles alarm		Boolean		1	0: inactive 1: active	0	Indicates that the configured run cycle maintenance interval is exceeded on this motor channel
.3	M1 - error count alarm		Boolean		2	0: inactive 1: active	0	Indicates that the configured maintenance error count interval is exceeded on this motor channel
.5	M2 - runtime alarm		Boolean		4	0: inactive 1: active	0	Indicates that the configured runtime maintenance interval is exceeded on this motor channel
6	M2 - run cycles alarm		Boolean		5	0: inactive 1: active	0	Indicates that the configured run cycle maintenance interval is exceeded on this motor channel
.7	M2 - error count alarm		Boolean		6	0: inactive 1: active	0	Indicates that the configured maintenance error count interval is exceeded on this motor channel
.9	M3 - runtime alarm		Boolean		8	0: inactive 1: active	0	Indicates that the configured runtime maintenance interval is exceeded on this motor channel
10	M3 - run cycles alarm		Boolean		9	0: inactive 1: active	0	Indicates that the configured run cycle maintenance interval is exceeded on this motor channel
.11	M3 - error count alarm		Boolean		10	0: inactive 1: active	0	Indicates that the configured maintenance error count interval is exceeded on this motor channel
.13	M4 - runtime alarm		Boolean		12	0: inactive 1: active	0	Indicates that the configured runtime maintenance interval is exceeded on this motor channel

Index/ .sub	Parameter	Acc ess	Data Type	Length	Bit Off- set	Value Range	Def ault	Description
14	M4 - run cycles alarm		Boolean		13	0: inactive 1: active	0	Indicates that the configured run cycle maintenance interval is exceeded on this motor channel
.15	M4 - error count alarm		Boolean		14	0: inactive 1: active	0	Indicates that the configured maintenance error count interval is exceeded on this motor chan- nel
Diagnostics of the Motor Channels								
229 (0xE5)	MCC Diag Port	r	Record (1)	4 byte				Diagnostics of the motor chan- nels
.1	M1 - fuse defect		Boolean		0	0: inactive 1: active	0	Indicates a blown fuse in this motor channel
.2	M1 - power output over- load		Boolean		1	0: inactive 1: active	0	Indicates an overload at the out- put of this motor channel
.5	M2 - fuse defect		Boolean		4	0: inactive 1: active	0	Indicates a blown fuse in this motor channel
.6	M2 - power output over- load		Boolean		5	0: inactive 1: active	0	Indicates an overload at the out- put of this motor channel
.9	M3 - fuse defect		Boolean		8	0: inactive 1: active	0	Indicates a blown fuse in this motor channel
.10	M3 - power output over- load		Boolean		9	0: inactive 1: active	0	Indicates an overload at the out- put of this motor channel
.13	M4 - fuse defect		Boolean		12	0: inactive 1: active	0	Indicates a blown fuse in this motor channel
.14	M4 - power output over- load		Boolean		13	0: inactive 1: active	0	Indicates an overload at the out- put of this motor channel
Diagnostics of the IO Channels								
230 (0xE6)	IOC Diag	r	Record (1)	4 byte				Diagnostics of the IO channels
.1	IO1/2 sup- ply over- load alarm		Boolean		0	0: inactive 1: active	0	Indicates an overload of the sup- ply to this IO connection
2	IO1 output overload alarm		Boolean		1	0: inactive 1: active	0	Indicates an overload at the out- put of this IO connection
3	IO2 output overload alarm		Boolean		2	0: inactive 1: active	0	Indicates an overload at the out- put of this IO connection
5	IO3/4 sup- ply over- load alarm		Boolean		4	0: inactive 1: active	0	Indicates an overload of the sup- ply to this IO connection
6	IO3 output overload alarm		Boolean		5	0: inactive 1: active	0	Indicates an overload at the out- put of this IO connection
7	IO4 output overload alarm		Boolean		6	0: inactive 1: active	0	Indicates an overload at the out- put of this IO connection

Index/.sub	Parameter	Access	Data Type	Length	Bit Off-set	Value Range	Default	Description
9	IO5/6 supply overload alarm		Boolean		8	0: inactive 1: active	0	Indicates an overload of the supply to this IO connection
10	IO5 output overload alarm		Boolean		9	0: inactive 1: active	0	Indicates an overload at the output of this IO connection
11	IO6 output overload alarm		Boolean		10	0: inactive 1: active	0	Indicates an overload at the output of this IO connection
13	IO7/8 supply overload alarm		Boolean		12	0: inactive 1: active	0	Indicates an overload of the supply to this IO connection
14	IO7 output overload alarm		Boolean		13	0: inactive 1: active	0	Indicates an overload at the output of this IO connection
15	IO8 output overload alarm		Boolean		14	0: inactive 1: active	0	Indicates an overload at the output of this IO connection
Diagnostics of the Module								
231 (0x0E7)	Module DIAG	r	Record (1)	1 byte				Diagnostics of the module
.1	Module - motor power fail		Boolean		0	0: inactive 1: active		Indicates a PWR power supply is missing

Table 5.6

1. Internal resolution 15 min

5.7 Device-Specific Commands

Use the following commands to reset the module and the maintenance parameter counters for the motors.

Index/.sub		Description
Device Reset		
129 (0x81)	Application Reset	Resets all device-specific parameters
130 (0x82)	Restore Factory Settings	Restores the factory settings
Maintenance Reset		
176 (0XB0)	Maintenance Reset Motor 1	Resets the counters for motor 1 <ul style="list-style-type: none"> • Runtime • Run cycles • Errors
177 (0xB1)	Maintenance Reset Motor 2	Resets the counters for motor 2 <ul style="list-style-type: none"> • Runtime • Run cycles • Errors

Index/.sub		Description
178 (0xB2)	Maintenance Reset Motor 3	Resets the counters for motor 3 <ul style="list-style-type: none">• Runtime• Run cycles• Errors
179 (0xB3)	Maintenance Reset Motor 4	Resets the counters for motor 4 <ul style="list-style-type: none">• Runtime• Run cycles• Errors

Table 5.7

6 Repair and Servicing

The device must not be repaired, changed, or manipulated. In case of failure, always replace the device with an original device.

7 Appendix

7.1 Event Codes

Standard Applications

Event	Instance	Type	Mode	Event		Description
				Qualifier	Code	
Parameter error	APP	Error	Appear/Disappear	0xF4/0xB4	0x6320	Internal parameter set corrupted <ul style="list-style-type: none"> Reset device Replace device
Hardware error	APP	Error	Appear/Disappear	0xF4/0xB4	0x5010	Hardware error beyond repair <ul style="list-style-type: none"> Replace device

Table 7.1

Maintenance Requirement

Event	Instance	Type	Mode	Event		Description
				Qualifier	Code	
Motor maintenance diagnosis	APP	Warning	Appear/Disappear	0xE4/0xA4	0x8D01	The interval for a configured maintenance cycle has been reached

Table 7.2

Out of Specification

Event	Instance	Type	Mode	Event		Description
				Qualifier	Code	
Temperature range exceeded	APP	Warning	Appear/Disappear	0xE4/0xA4	0x8D43	Ambient temperature outside of the specified temperature range <ul style="list-style-type: none"> Check the device environment
Motor power fail	APP	Warning	Appear/Disappear	0xE4/0xA4	0x8D50	PWR power failure or low voltage <ul style="list-style-type: none"> Check connection and power supply
Power output overload	APP	Warning	Appear/Disappear	0xE4/0xA4	0x8D51	Overload detected on power output (motor port) <ul style="list-style-type: none"> Check diagnostic information for details
I/O port overload	APP	Warning	Appear/Disappear	0xE4/0xA4	0x8D52	Overload detected on IO-Link channel <ul style="list-style-type: none"> Check diagnostic information for details Check the cables, connections and connected devices on the corresponding channel

Table 7.3

7.2 Error Codes

In the case of a fault, the module transmits the following error codes. An error code consists of two bytes. The byte with the higher value, in this case 0x80, represents the IO-Link device as the transmitter. The byte with the lower value represents the actual fault.

Fault	Error Code	Comment
Unavailable index	0x8011	R/W access to unavailable parameter index
Unavailable subindex	0x8012	R/W access to unavailable parameter subindex
Service temporarily unavailable	0x8020	Access to parameter not possible due to device status
Service temporarily unavailable, local control	0x8021	Access to parameter blocked due to local control of the module
Service temporarily unavailable, device control	0x8022	Access to parameter blocked due to incorrect device status
Access denied	0x8023	Attempt to write read-only parameter
Parameter value in invalid value range	0x8030	For all R/W parameters outside of the valid value range
Parameter value too large	0x8031	For all R/W parameters above the valid value range
Parameter value too small	0x8032	For all R/W parameters beneath the valid value range
Parameter too long	0x8033	Too much data [bytes] was transmitted for the parameter
Parameter too short	0x8034	Insufficient data [bytes] was transmitted for the parameter
Function unavailable	0x8035	Unsupported system command
Function temporarily unavailable	0x8036	Access to command that is unavailable due to device health
Invalid parameter set	0x8040	Parameter collision during individual parameter transmission
Inconsistent parameter set	0x8041	Parameter interference during block parameter transmission

Table 7.4

7.3 ASCII table

hex	dec	ASCII	hex	dec	ASCII	hex	dec	ASCII	hex	dec	ASCII
00	0	NUL	20	32	Space	40	64	@	60	96	'
01	1	SOH	21	33	!	41	65	A	61	97	a
02	2	STX	22	34	"	42	66	B	62	98	b
03	3	ETX	23	35	#	43	67	C	63	99	c
04	4	EOT	24	36	\$	44	68	D	64	100	d
05	5	ENQ	25	37	%	45	69	E	65	101	e
06	6	ACK	26	38	&	46	70	F	66	102	f
07	7	BEL	27	39	'	47	71	G	67	103	g
08	8	BS	28	40	(48	72	H	68	104	h
09	9	HT	29	41)	49	73	I	69	105	i
0A	10	LF	2A	42	*	4A	74	J	6A	106	j
0B	11	VT	2B	43	+	4B	75	K	6B	107	k
0C	12	FF	2C	44	,	4C	76	L	6C	108	l
0D	13	CR	2D	45	-	4D	77	M	6D	109	m
0E	14	SO	2E	46	.	4E	78	N	6E	110	n
0F	15	SI	2F	47	/	4F	79	O	6F	111	o
10	16	DLE	30	48	0	50	80	P	70	112	p
11	17	DC1	31	49	1	51	81	Q	71	113	q
12	18	DC2	32	50	2	52	82	R	72	114	r
13	19	DC3	33	51	3	53	83	S	73	115	s
14	20	DC4	34	52	4	54	84	T	74	116	t
15	21	NAK	35	53	5	55	85	U	75	117	u
16	22	SYN	36	54	6	56	86	V	76	118	v
17	23	ETB	37	55	7	57	87	W	77	119	w
18	24	CAN	38	56	8	58	88	X	78	120	x
19	25	EM	39	57	9	59	89	Y	79	121	y
1A	26	SUB	3A	58	:	5A	90	Z	7A	122	z
1B	27	ESC	3B	59	;	5B	91	[7B	123	{
1C	28	FS	3C	60	<	5C	92	\	7C	124	
1D	29	GS	3D	61	=	5D	93]	7D	125	}
1E	30	RS	3E	62	>	5E	94	^	7E	126	~
1F	31	US	3F	63	?	5F	95	_	7F	127	DEL

Your automation, our passion.

Explosion Protection

- Intrinsic Safety Barriers
- Signal Conditioners
- FieldConnex® Fieldbus
- Remote I/O Systems
- Electrical Ex Equipment
- Purge and Pressurization
- Industrial HMI
- Mobile Computing and Communications
- HART Interface Solutions
- Surge Protection
- Wireless Solutions
- Level Measurement

Industrial Sensors

- Proximity Sensors
- Photoelectric Sensors
- Industrial Vision
- Ultrasonic Sensors
- Rotary Encoders
- Positioning Systems
- Inclination and Acceleration Sensors
- Fieldbus Modules
- AS-Interface
- Identification Systems
- Displays and Signal Processing
- Connectivity

Pepperl+Fuchs Quality

Download our latest policy here:

www.pepperl-fuchs.com/quality

