

# VisuNet FLX Panel

RM-320P-\*

PC-320P-\*

DM-320P-\*

Manual



Your automation, our passion.

 **PEPPERL+FUCHS**

---

With regard to the supply of products, the current issue of the following document is applicable:  
The General Terms of Delivery for Products and Services of the Electrical Industry, published  
by the Central Association of the Electrical Industry (Zentralverband Elektrotechnik und Elek-  
troindustrie (ZVEI) e.V.) in its most recent version as well as the supplementary clause:  
"Expanded reservation of proprietorship"

**Worldwide**

Pepperl+Fuchs Group  
Lilienthalstr. 200  
68307 Mannheim  
Germany  
Phone: +49 621 776 - 0  
E-mail: [info@de.pepperl-fuchs.com](mailto:info@de.pepperl-fuchs.com)

**North American Headquarters**

Pepperl+Fuchs Inc.  
1600 Enterprise Parkway  
Twinsburg, Ohio 44087  
USA  
Phone: +1 330 425-3555  
E-mail: [sales@us.pepperl-fuchs.com](mailto:sales@us.pepperl-fuchs.com)

**Asia Headquarters**

Pepperl+Fuchs Pte. Ltd.  
P+F Building  
18 Ayer Rajah Crescent  
Singapore 139942  
Phone: +65 6779-9091  
E-mail: [sales@sg.pepperl-fuchs.com](mailto:sales@sg.pepperl-fuchs.com)  
<https://www.pepperl-fuchs.com>

<b>1</b>	<b>History of the Manual .....</b>	<b>4</b>
<b>2</b>	<b>Introduction.....</b>	<b>5</b>
2.1	Content of this Document.....	5
2.2	Manufacturer .....	5
2.3	Target Group, Personnel .....	5
2.4	Symbols Used .....	6
<b>3</b>	<b>Product Description .....</b>	<b>7</b>
3.1	Overview.....	7
3.2	Reference Documents.....	9
3.3	Cybersecurity Information .....	10
3.4	Technical Data.....	12
3.5	Dimensions and Nameplates.....	21
<b>4</b>	<b>Mechanical Installation .....</b>	<b>25</b>
4.1	Unpacking .....	25
4.2	Panel Installation .....	26
4.3	General Installation Information .....	27
4.4	Mounting the Panel in the enclosure .....	27
<b>5</b>	<b>Electrical Installation.....</b>	<b>34</b>
5.1	Equipotential Bonding of the VisuNet FLX Panel .....	35
5.2	Power Connection.....	36
<b>6</b>	<b>Interfaces.....</b>	<b>38</b>
6.1	Computing Unit - Interface Connectors.....	38
6.1.1	Power Limitations.....	38
<b>7</b>	<b>Maintenance.....</b>	<b>39</b>
7.1	Exchanging the BPC3200-* or DMU3200-* .....	40
7.2	Dismounting the Display Unit.....	46
7.3	Support Pixel Errors .....	47
7.4	Gloves Tested for Touch Sensitivity .....	48
7.5	Cleaning.....	49
<b>8</b>	<b>Accessories.....</b>	<b>50</b>

# 1 History of the Manual

The following editions of the manual have been released:

Version	Comments
04/2021	- First edition
07/2021	- Second edition
10/2021	- Addition of references - Additional warnings regarding intended use - Correction SELV/PELV or NEC class 2 - Addition ATEX Zone 2/22 (P+F self declaration)
06/2022	- Added Note where to find information about chemical resistance (Chapter 7.5) - Addition UL certification - Removal ATEX Zone 2/22 (P+F self declaration) - Addition ThinManager Ready
07/2022	- Minor marking corrections
05/2023	- Addition of VisuNet RM Shell 6
07/2024	- Addition optional IGEL OS operating system - Update PC OS Windows® 10 Enterprise LTSC 2021 - Addition CCC certification information

## 2 Introduction

### 2.1 Content of this Document

This document contains information that you need in order to use your product throughout the applicable stages of the product life cycle. These can include the following:

- Product identification
- Delivery, transport, and storage
- Mounting and installation
- Commissioning and operation
- Maintenance and repair
- Troubleshooting
- Dismounting
- Disposal



---

**Note**

This document does not substitute the instruction manual.

---



---

**Note**

For full information on the product, refer to the instruction manual and further documentation on the Internet at [www.pepperl-fuchs.com](http://www.pepperl-fuchs.com).

---

The documentation consists of the following parts:

- Present document
- Instruction manual
- Datasheet

Additionally, the following parts may belong to the documentation, if applicable:

- Type examination certificate
- EU declaration of conformity
- Attestation of conformity
- Certificates
- Control drawings
- Additional documents

### 2.2 Manufacturer

Pepperl+Fuchs Group Lilienthalstraße 200, 68307 Mannheim, Germany
--

Internet: <a href="http://www.pepperl-fuchs.com">www.pepperl-fuchs.com</a>
--

### 2.3 Target Group, Personnel

Responsibility for planning, assembly, commissioning, operation, maintenance, and dismantling lies with the plant operator.

Only appropriately trained and qualified personnel may carry out mounting, installation, commissioning, operation, maintenance, and dismantling of the product. The personnel must have read and understood the instruction manual and the further documentation.

Prior to using the product make yourself familiar with it. Read the document carefully.

## 2.4 Symbols Used

This document contains symbols for the identification of warning messages and of informative messages.

### Warning Messages

You will find warning messages, whenever dangers may arise from your actions. It is mandatory that you observe these warning messages for your personal safety and in order to avoid property damage.

Depending on the risk level, the warning messages are displayed in descending order as follows:



---

#### **Danger!**

This symbol indicates an imminent danger.

Non-observance will result in personal injury or death.

---



---

#### **Warning!**

This symbol indicates a possible fault or danger.

Non-observance may cause personal injury or serious property damage.

---



---

#### **Caution!**

This symbol indicates a possible fault.

Non-observance could interrupt the device and any connected systems and plants, or result in their complete failure.

---

### Informative Symbols



---

#### **Note**

This symbol brings important information to your attention.

---



---

#### **Action**

1. This symbol indicates a paragraph with instructions. You are prompted to perform an action or a sequence of actions.

## 3 Product Description

### 3.1 Overview

VisuNet FLX Panels consist of a display unit with touch screen in combination with a computing unit. Various display sizes and configurable computing units like BPC3200-\* and DMU3200-\* are available.

The VisuNet FLX panels are designed for use in hazardous locations ATEX/IECEX Zone 2/22 and Class I,II,III Div 2 and non-hazardous area applications. The different display sizes and configuring options lead to the highest application flexibility. Due to a fully modular design, the new platform, which is geared to the needs of the (petro-) chemical and pharmaceutical industries, the HMIs can be configured to fit exactly and enable simple and fast customer adjustments in the field.

**Pharma suitable concept:** The VisuNet FLX fulfills with its seal concept strict hygiene requirements. The gap free surface which is available with a typical surface roughness of 0.8 µm and rounded edges of the bezel prevent accumulation of liquids or bacteria. Display and seals are chemically resistant to typical cleaning agents.

In addition, individual solutions can also be created and manufactured at Pepperl+Fuchs' Solution Engineering Centers (SEC), which are located around the world.

### VisuNet FLX Panel Components



Figure 3.1

No.	Description
(1)	<b>Display Unit:</b> 21.5" display, touch screen, hardened front glass, available with optical bonding or non- optical bonding. 19" display, touch screen, hardened front glass with optical bonding 15" display, touch screen, hardened front glass with optical bonding
(2)	<b>RAM / Storage:</b> RAM available as 4 GB, 8 GB and 16 GB DDR4-2133 Storage available as 64 GB, 256 GB and 512 GB, expandable with qualified Pepperl+Fuchs components.
(3)	<b>Computing Unit:</b> (TCU, PCU or DMU): processor, SSD and memory, Ex circuits, interface modules

An extra system housing is available in which the VisuNet FLX panel can be easily installed in. Refer to the VisuNet FLX system manual (RM-320S-\*, PC-320S-\* and DM-320S-\*) for further information.







**Note**

For a description of the product model nomenclature, see the VisuNet FLX RM (RM-320P-\*), VisuNet FLX PC (PC-320P-\*) or VisuNet FLX DM (DM-320P-\*) product datasheets at [www.pepperl-fuchs.com](http://www.pepperl-fuchs.com).



### 3.2 Reference Documents

#### Important Instructions and Manuals for Operating the Device

	Documentation	Contents
	<p>You are here: <b>VisuNet FLX Panel manual</b></p>	<ul style="list-style-type: none"> <li>• Panel installation</li> <li>• Information regarding 21.5", 19" and 15.6" DPU</li> <li>• Connecting the BPC3200-* to the DPU3200-*</li> <li>• Panel dimensions</li> <li>• Cut out dimensions</li> <li>• Support Pixel Errors</li> <li>• Gloves Tested for Touch Sensitivity</li> </ul>
	<p>VisuNet FLX System manual</p>	<ul style="list-style-type: none"> <li>• System installation (mechanical, electrical)</li> <li>• Power connection (DC and AC)</li> <li>• Installing peripherals</li> <li>• Maintenance</li> <li>• Chemical Resistance (immersion test results of common cleaning agents)</li> </ul>
	<p>BPC3200-* manual</p>	<ul style="list-style-type: none"> <li>• Technical data and expanded technical data</li> <li>• Electrical installation</li> <li>• I/O connection</li> <li>• DIP Switch positions when exchanging a computing unit</li> <li>• BIOS settings</li> </ul>
	<p>DMU3200-* manual</p>	<ul style="list-style-type: none"> <li>• Product Versions</li> <li>• Technical data</li> <li>• I/O Connection</li> <li>• Opening the device</li> </ul>
	<p>VisuNet RM Shell 6 manual</p>	<ul style="list-style-type: none"> <li>• Overview</li> <li>• App Management</li> <li>• System Settings</li> <li>• Factory Reset</li> <li>• How-tos</li> </ul>
	<p>IGEL OS security documentation</p>	<ul style="list-style-type: none"> <li>- Security context</li> <li>- Maintenance and management</li> </ul>

### 3.3 Cybersecurity Information

The **VisuNet FLX** is developed secure according to IEC 62443-4-1 for the area of application defined here. For cybersecure operation and protection of the device, the plant operator must implement the measures specified in this section.

#### 1. Security Context and intended use

The VisuNet FLX is intended to be used in industrial applications. It should operate in an "Off-Plant", "Automation", "Intranet" or "Enterprise" network. This is a secure and monitored network with known and trusted participants that is separated (physically or logically) from the internet.

The device should be locked against hardware manipulation.

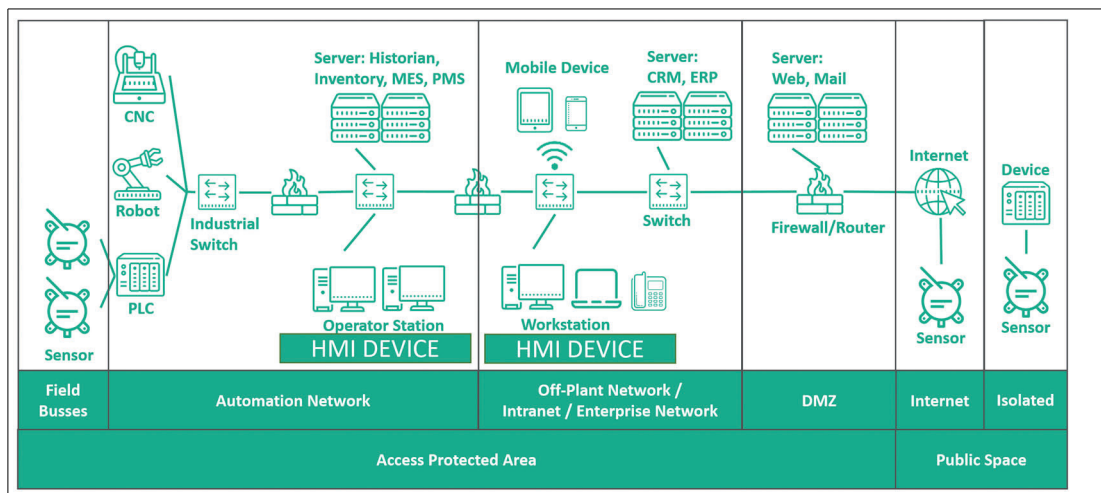

Figure 3.2

#### 2. Commissioning of the device

The following measures must be implemented on the device for commissioning:

Hardening:	Change the default BIOS password.
Additional security layers:	Configuration of personal user accounts, user credentials, and rights with strong passwords. Harden the used operating system and disable all unused services and ports. Contact the vendor of the operating system for more information. Encrypt the used operating system using the credential store in the TPM.
Wi-Fi devices:	When using Wi-Fi devices, ensure that highest encryption protocols (like WPA3) are used.
Recommendation for security-related tools:	Password manager KeePass for generating and storing passwords.

**3. Operation of the device**

The following measures must be implemented on the device for operation:

Lock device:	The device should be locked against hardware manipulation.
Additional security layers:	BIOS Password change: every 2 years.
Recommendation for security-related tools:	Firewall for separating the internet from the protected network. IDS ("intrusion detection system") to detect access to disabled or unauthorized ports. Use virus scanner and malware detection.
Maintenance and management:	Subscribe and monitor the Cyber Security Information feed from the Pepperl+Fuchs homepage <a href="https://www.pepperl-fuchs.com/">https://www.pepperl-fuchs.com/</a> . Depending on the used operating system, check the vendors website regularly for Security Advisories postings and install updates regularly.

**4. Decommissioning of the device**

The following measures must be implemented for decommissioning the device:

OS data:	Contact vendor of the operating system how to perform a "Factory Reset" and wipe OS data.
Out of service:	Use a third-party data wiping tool to securely wipe the hard drive or destroy the built-in SSD (only when SSD is installed).

## 3.4 Technical Data

### PC-320P-\* (Personal Computer)

General specifications	
Type	Personal Computer

Hardware	
Processor	Intel® Core™ i5-7300U Intel® Celeron™ 3965U
RAM	2x SO-DIMM slots, supports up to 32 GB DDR4-2133 (one SO-DIMM slot)  <b>Configurable RAM options:</b> Industrial temperature grade (temperature option A): A: 1x 4 GB DDR4-2133 [Celeron] B: 1x 8 GB DDR4-2133 C: 1x 16 GB DDR4-2133  Wide temperature grade (temperature option B): K: 1x 4 GB DDR4-2133 [Celeron] L: 1x 8 GB DDR4-2133 M: 1x 16 GB DDR4-2133
Mass storage	<b>Storage interface:</b> 1x M.2 2242/2280 M Key, PCIe + SATA 3 1x M.2 2242/2280 M Key, 2242/2280, SATA 3, supports Raid 0/1 [i5]  <b>Configurable storage options:</b> Industrial temperature grade (temperature option A): A: 64-GB M.2 SATA 3 [Celeron] D: 256-GB M.2 NVMe 1.3 (PCIe 4x) E: 512-GB M.2 NVMe 1.3 (PCIe 4x)  Wide temperature grade (temperature option B): K: 64-GB M.2 SATA 3 [Celeron] P: 256-GB M.2 NVMe 1.3 (PCIe 4x) Q: 512-GB M.2 NVMe 1.3 (PCIe 4x)

#### Note

For further details regarding I/Os refer to the BPC3200-\* manual.

Software	
Operating system	Microsoft® Windows® 10 IoT Enterprise 2021 LTSC (x64)



**RM-320P-\* (Remote Monitor)**

General specifications	
Type	RM-320P-*: Remote Monitor

Hardware	
Processor	Intel® Celeron™ 3965U
RAM	<b>Configurable RAM options:</b> A: 1x 4 GB DDR4-2133, industrial temperature grade [temperature class A] K: 1x 4 GB DDR4-2133, wide temperature grade
Mass storage	<b>Storage interface:</b> 1x M.2 2242/2280 M Key, PCIe + SATA 3  <b>Configurable storage options:</b> A: 64-GB M.2 SATA 3, industrial temperature grade [temperature class A] K: 64-GB M.2 SATA 3, wide temperature grade



**Note**

For further details regarding I/Os refer to the BPC3200-\* manual.

Software	
Operating system	VisuNet RM Shell 6 (based on Windows® 10 Enterprise LTSC 2021)  <b>Optional:</b> T: ThinManager Ready [Celeron, 4 GB RAM, no storage] J: IGEL OS 12 based on Linux, pre-installed without licence, [Celeron, 8 GB RAM, 64-GB SSD] I: IGEL OS 11 based on Linux, pre-installed without licence [Celeron, 8 GB RAM, 64-GB SSD]

**PC-320P-\* (Personal Computer) and RM-320P-\* (Remote Monitor)**

Supply	
Input current	max. 4 A, max. 80 W Refer to chapter <b>6.1.1 Power Limitations</b> for further information.
Power consumption	
DC	20 ... 28 V d.c. / 4.0 A (SELV/PELV or NEC class 2) For connections designation refer to the VisuNet FLX manual.

Indicators/operating means	
Display	
Type	Liquid Crystal Display (LCD) with LED backlight
Screen diagonal	Configurable display options: 22GT: 54.61 cm (21.5") [temperature class A] 22FC: 54.61 cm (21.5") (Display might react sluggishly below 0°C) 19SC: 48.26 cm (19") 15FC: 39.62 cm (15.6")
Resolution	22GT, 22FC, 15FC: 1920 x 1080 pixels (Full HD) Aspect Ratio (16:9) 19SC: 1280 x 1024 pixels (SXGA) Aspect Ratio (5:4)
Color depth	24 bit (16.7 M) color
Contrast	Typically 22GT: 1000:1 22FC: 5000:1 19SC: 1000:1 15FC: 800:1
Brightness	Configurable display options: 22GT: 250 cd/m <sup>2</sup> 22FC: 300 cd/m <sup>2</sup> 19SC: 450 cd/m <sup>2</sup> 15FC: 450 cd/m <sup>2</sup>
Reading angle	22GT: 178° in all directions 22FC, 19SC: horizontal: 170°, vertical: 160° 15FC: 170° in all directions
Life span	22GT: back lamp life: 30.000-hrs typical half life, at 25°C (77°F) 22FC, 19SC, 15FC: back lamp life: 50.000-hrs typical half life, at 25°C (77°F)
Input devices	
Touch screen	Configurable Display Options: 10-finger multi-touch, glove-friendly 22GT: Capacitive touch, no optical bonding 22FC, 19SC, 15FC: Capacitive touch, optical bonding

Interface	
Interface type	1 x DisplayPort 1.2 (DP++) 1 x mini DisplayPort 1.2 (DP++ w/ mono locking screw) 1 x Audio Line-out 2 x USB Ex i ports prepared for Pepperl+Fuchs intrinsically safe keyboard 2 x USB 3.1 Gen1 (5 Gbps) ports 1 x USB 2.0 port 2 x LAN ports (RJ45, 10/100/1000 Mbps) 2 x RS232/422/485 (BIOS configurable) with 5V/12V to power peripherals (1 x DB9 male + 1 x RJ45)

2024-07

Directive conformity	
<b>Electromagnetic compatibility</b>	
Directive 2014/30/EU	EN 61326-1:2013 (ind. Locations) EN 61000-6-4:2007+A1:2011 EN 55035:2017/A11:2020 EN 55011:2016+A1:2017
<b>Explosion protection</b>	
Directive 2014/34/EU	EN IEC 60079-0:2018 EN IEC 60079-7:2015/A1:2018 EN 60079-11:2012 EN 60079-31:2014
RoHS	
Directive 2011/65/EU (RoHS)	EN IEC 63000:2018

Ambient conditions	
Operating temperature	Temperature classes: A: 0 ... 45 °C (32 ... 113 °F) B: -20 ... 55 °C (-4 ... 131 °F) [with wide temperature grade RAM/storage and optically bonded display unit]
Storage temperature	-20 ... 65 °C (-4 ... 149 °F)
Relative humidity	max. relative humidity 93% at 40°C (non-condensing) according to EN60068-2-78
Climatic conditions	Passive cooling, no rotating parts
Altitude	Operating altitude max. 2000 m
Shock resistance	18 shocks 15 g, 11 ms all axis, IEC 60068-2-27
Vibration resistance	10 ... 150 Hz, +/- 0.075 mm, 1 g, 10 cycles per axis according to EN60068-2-6

Mechanical specifications	
Degree of protection	Front side: IP66/Type 4X Back side: IP20
Material	Front bezel: Stainless steel AISI304 (glass, silicone gasket) Backside: Painted aluminum sheet metal
Installation	Panel mount (additional Mounting Kits available) installed in boundary wall, in cabinet wall or special enclosure
Mass	22GT, 22FC and 19SC: approx. 8 kg 15FC: 5.4 kg
Dimensions	22 inches: 567 mm x 358 mm x 68 mm 19 inches: 485.7 mm x 410.5 mm x 68 mm 15 inches: 434 mm x 283.4 mm x 67 mm For cut out dimensions refer to chapter 4.4 <b>Mounting the Panel Into the Enclosure.</b>

International approvals	
<b>UL OrdLoc</b> UL approval E223772	
Approved for	UL61010-1 Ed.3 UL 61010-2-201 Ed2 CAN/CSA C22.2 No 61010-1-12 CAN/CSA C22.2 No 61010-2-201
<b>UL HazLoc</b> UL approval E492874	
Approved for	<p>NI circuits for CL I, DIV 2, GP A-D CL II, DIV 2, GP E, F, G CL III</p> <p>NI circuits for CL I, ZN 2, IIC CL II, ZN 22, IIIB CL III, ZN 22, IIIA Install per drawing 116-0478</p> <p>Mounting in CL I, DIV 2, GP A-D, T4 CL II, DIV 2, GP E, F, G, T4 CL III</p> <p>Mounting in CL I, ZN 2, IIC, T4 CL II, ZN 22, IIIB, T85°C CL III, ZN 22, IIIA, T85°C</p>
<b>ATEX approval</b>	
ATEX certificate	UL 22 ATEX 2479X
ATEX marking	II 3 G Ex ec [ic Gc] IIC T4 Gc
ATEX certificate	UL 22 ATEX 2480U
ATEX marking	II 3D Ex tc [ic Dc] IIIC Dc
<b>IECEX approval</b>	
IECEX certificate	IECEX ULD 22.0017X
IECEX marking	Ex ec [ic Gc] IIC T4 Gc
IECEX certificate	IECEX ULD 22.0018U
IECEX marking	Ex tc [ic Dc] IIIC Dc
IECEX standards	IEC 60079-0:2017 Ed 7.0 IEC 60079-7:2017 Ed 5.1 IEC 60079-11:2011 Ed 6.0 IEC 60079-31:2013 Ed. 2
<b>CCC approval</b>	
CCC certificate	2023322309005728
CCC marking	Ex ec [ic Gc] IIC T4 Gc Ex tc [ic Dc] IIIC Dc
CCC standards	GB 3836.1-2021 GB/T 3836.3-2021 GB/T 3836.4-2021 GB/T 3836.31-2021



**DM-320P-\* (Direct Monitor)**

**General specifications**

Type	Direct Monitor
------	----------------

**Supply**

Input current	max. 1.5 A, max. 30 W
---------------	-----------------------

**Power consumption**

DC	20 ... 28 V d.c. / 1.5 A (SELV/PELV or NEC class 2) For connections designation refer to the VisuNet FLX manual.
----	---

**Indicators/operating means**

**Display**

Type	Liquid Crystal Display (LCD) with LED backlight
Screen diagonal	Configurable display options: 22GT: 54.61 cm (21.5") [temperature class A] 22FC: 54.61 cm (21.5") (Display might react sluggishly below 0°C) 19SC: 48.26 cm (19") 15FC: 39.62 cm (15.6")
Resolution	22GT, 22FC, 15FC: 1920 x 1080 pixels (Full HD) Aspect Ratio (16:9) 19SC: 1280 x 1024 pixels (SXGA) Aspect Ratio (5:4)
Color depth	24 bit (16.7 M) color
Contrast	Typically 22GT: 1000:1 22FC: 5000:1 19SC: 1000:1 15FC: 800:1
Brightness	Configurable display options: 22GT: 250 cd/m <sup>2</sup> 22FC: 300 cd/m <sup>2</sup> 19SC: 450 cd/m <sup>2</sup> 15FC: 450 cd/m <sup>2</sup>
Reading angle	22GT: 178° in all directions 22FC, 19SC: horizontal: 170°, vertical: 160° 15FC: 170° in all directions
Life span	22FC, 19SC, 15FC: back lamp life: 50.000-hrs typical half life, at 25°C (77°F) 22GT: back lamp life: 30.000-hrs typical half life, at 25°C (77°F)

**Interface**

Interface type	1x Power input w/ 3-pin terminal block 1x HDMI 1x DVI-I 1x VGA 1x USB 1x OSD Menu w/ power button
----------------	--

Directive conformity	
<b>Electromagnetic compatibility</b>	
Directive 2014/30/EU	EN 61326-1:2013 (ind. Locations) EN 61000-6-4:2007+A1:2011 EN 55035:2017/A11:2020 EN 55011:2016+A1:2017
<b>Explosion protection</b>	
Directive 2014/34/EU	EN IEC 60079-0:2018 EN IEC 60079-7:2015/A1:2018 EN 60079-31:2014
<b>RoHS</b>	
Directive 2011/65/EU (RoHS)	EN IEC 63000:2018

Ambient conditions	
Operating temperature	Temperature classes: A: 0 ... 45 °C (32 ... 113 °F) B: -20 ... 55 °C (-4 ... 131 °F) [with wide temperature grade RAM/storage and optically bonded display unit]
Storage temperature	-20 ... 65 °C (-4 ... 149 °F)
Relative humidity	max. relative humidity 93% at 40°C (non-condensing) according to EN60068-2-78
Climatic conditions	Passive cooling, no rotating parts
Altitude	Operating altitude max. 2000 m
Shock resistance	18 shocks 15 g, 11 ms all axis, IEC 60068-2-27
Vibration resistance	10 ... 150 Hz, +/- 0.075 mm, 1 g, 10 cycles per axis according to EN60068-2-6

Mechanical specifications	
Degree of protection	Front side: IP66/Type 4X Back side: IP20
Material	Front bezel: Stainless steel AISI304 (glass, silicone gasket) Backside: Painted aluminum sheet metal
Installation	Panel mount (additional Mounting Kits available) installed in boundary wall, in cabinet wall or special enclosure
Mass	22GT, 22FC and 19SC: 6.5 kg 15FC: 4.4 kg
Dimensions	22 inches: 567 mm x 358 mm x 68 mm 19 inches: 485.7 mm x 410.5 mm x 68 mm 15 inches: 434 mm x 283.4 mm x 67 mm For cut out dimensions refer to the panel mount manual.

International approvals	
<b>UL OrdLoc</b> UL approval E223772	
Approved for	UL61010-1 Ed.3 UL 61010-2-201 Ed2 CAN/CSA C22.2 No 61010-1-12 CAN/CSA C22.2 No 61010-2-201
<b>UL HazLoc</b> UL approval E492874	
Approved for	Mounting in CL I, DIV 2, GP A-D, T4 CL II, DIV 2, GP E, F, G, T4 CL III  Mounting in CL I, ZN 2, IIC, T4 CL II, ZN 22, IIIB, T85°C CL III, ZN 22, IIIA, T85°C
<b>ATEX approval</b>	
ATEX certificate	UL 22 ATEX 2479X
ATEX marking	II 3 G Ex ec IIC T4 Gc
ATEX certificate	UL 22 ATEX 2480U
ATEX marking	II 3D Ex tc IIIC Dc
<b>IECEX approval</b>	
IECEX certificate	IECEX ULD 22.0017X
IECEX marking	Ex ec IIC T4 Gc
IECEX certificate	IECEX ULD 22.0018U
IECEX marking	Ex tc IIIC Dc
IECEX standards	IEC 60079-0:2017 Ed 7.0 IEC 60079-7:2017 Ed 5.1 IEC 60079-31:2013 Ed. 2
<b>CCC approval</b>	
CCC certificate	2023322309005727
CCC marking	Ex ec IIC T4 Gc Ex tc IIIC Dc
CCC standards	GB 3836.1-2021 GB/T 3836.3-2021 GB/T 3836.31-2021



**Note**

For further details regarding I/Os refer to the DMU3200-\* manual.



**Note**

For expanded technical data regarding e.g. storage capacity and reliability refer to the BPC3200-\* manual.

### Thermal Throttling

For the Celeron processor, CPU throttling via a thermal control circuit is used. Depending on the system load and environmental operating temperature, the performance of the CPU may be throttled.



#### Note

Assess the system performance in context with the applications intended environmental conditions, including operating temperature range.

---

### 3.5 Dimensions and Nameplates

#### Dimensions

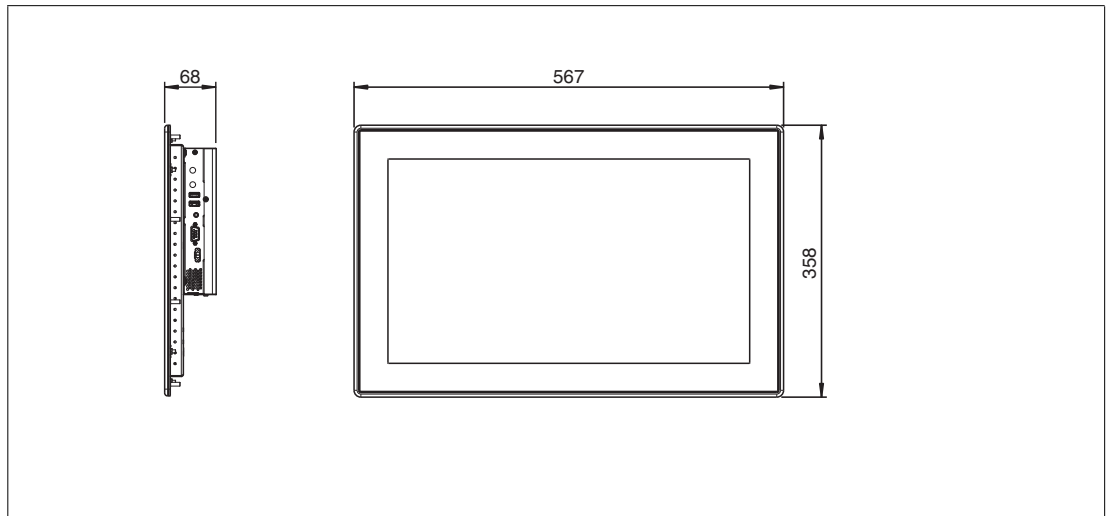

Figure 3.3 21.5" dimensions

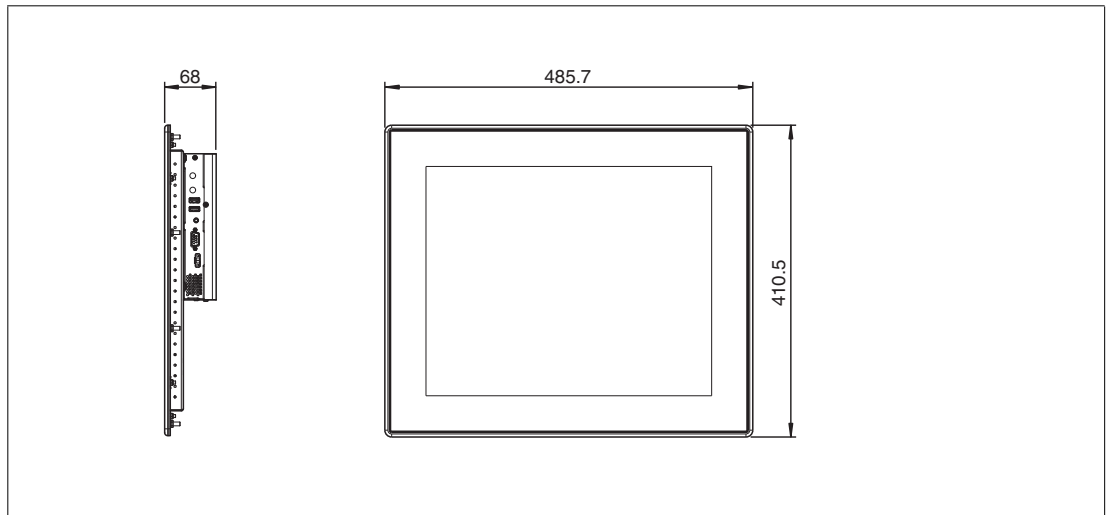

Figure 3.4 19" dimensions

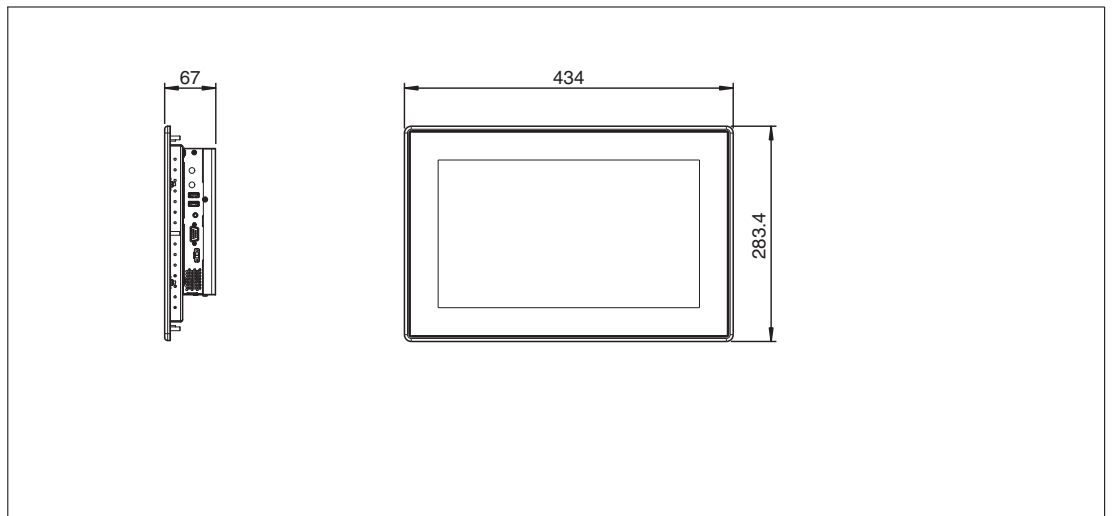

Figure 3.5 15" dimensions

2024-07



**Note**

For further information on the System dimensions refer to the VisuNet FLX System manual.

**Nameplates and Labels**

The following nameplates and labels are attached to the VisuNet FLX Panel:

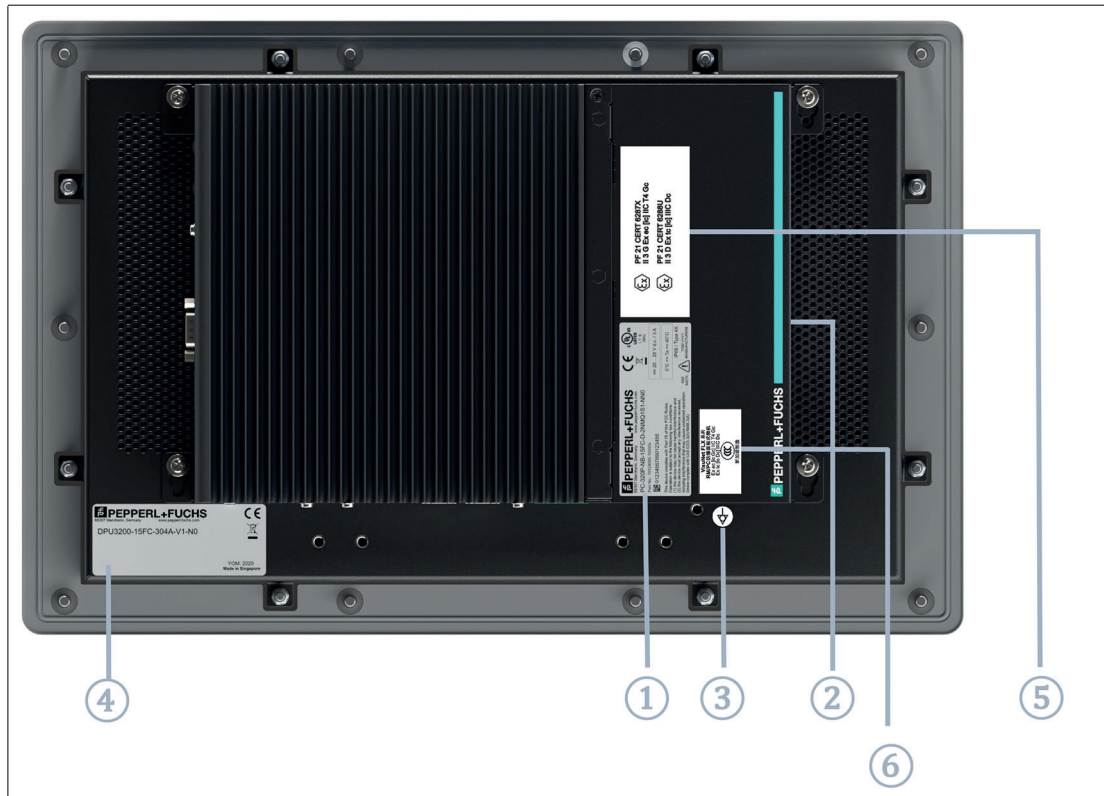

Figure 3.6 Overview of the attached labels and nameplates

**(1) Main label**

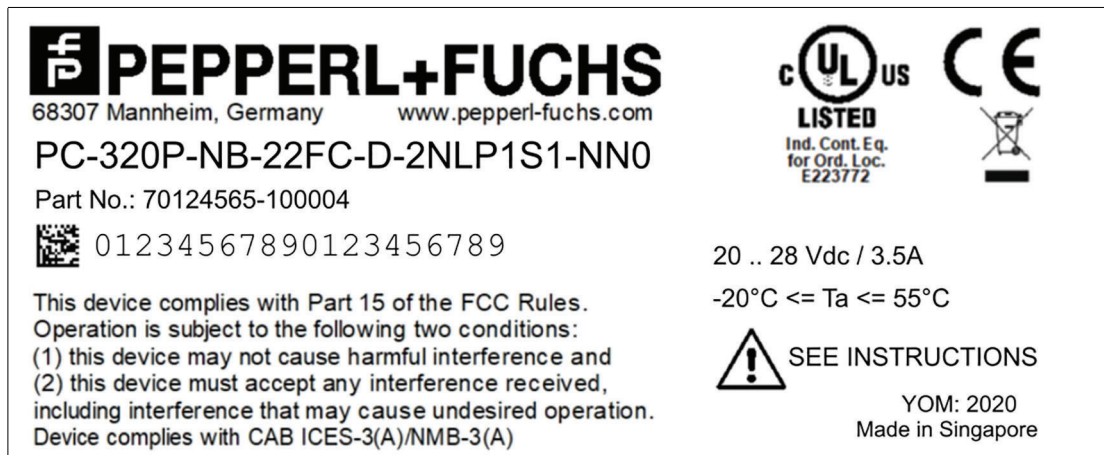

Figure 3.7

(2) Sublabel BPC3200-\*

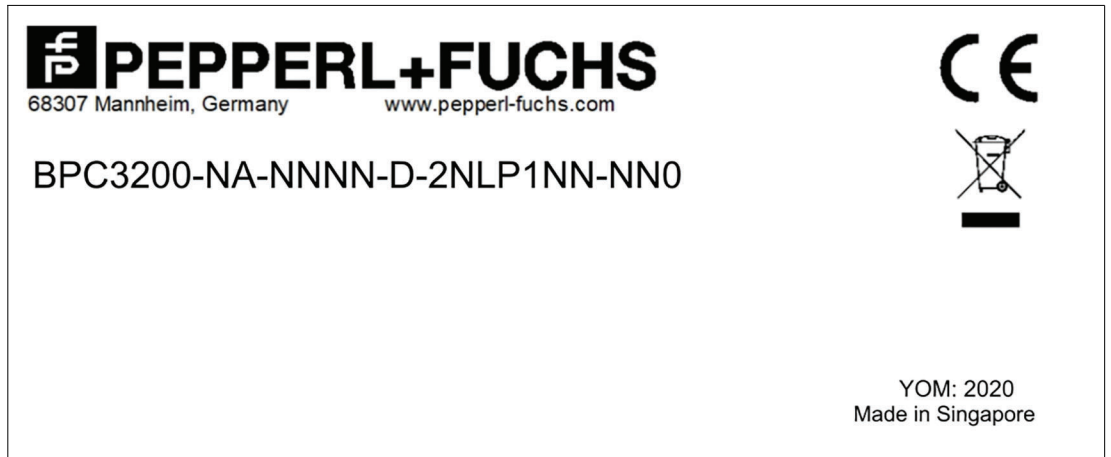

Figure 3.8

(3) Equipotential Bonding



Figure 3.9

(4) Sublabel DPU3200-\*

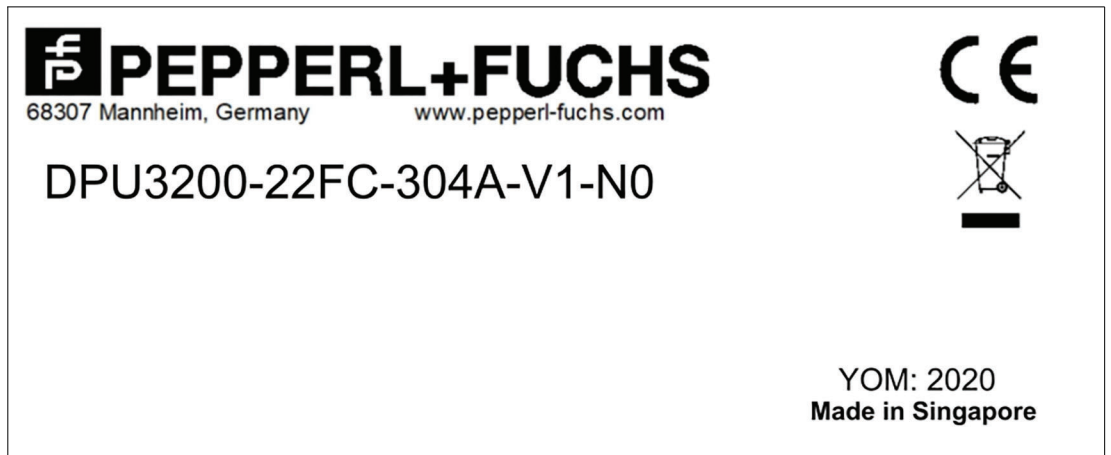

Figure 3.10

(5) Certification label RM-320P-\* and PC-320P-\*

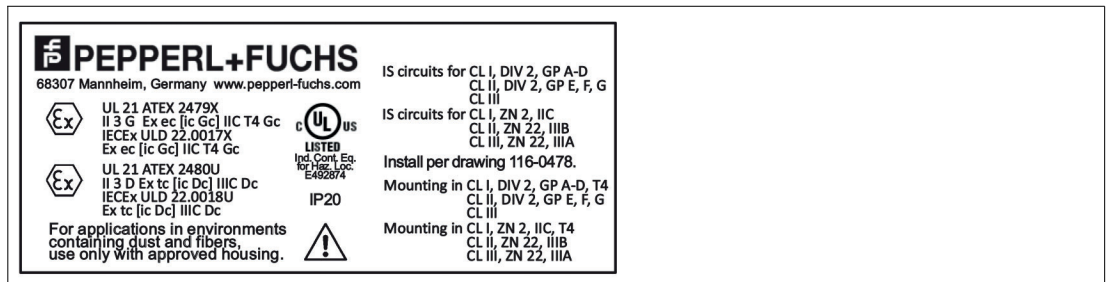

Figure 3.11

(5) Certification label DM-320P-\*

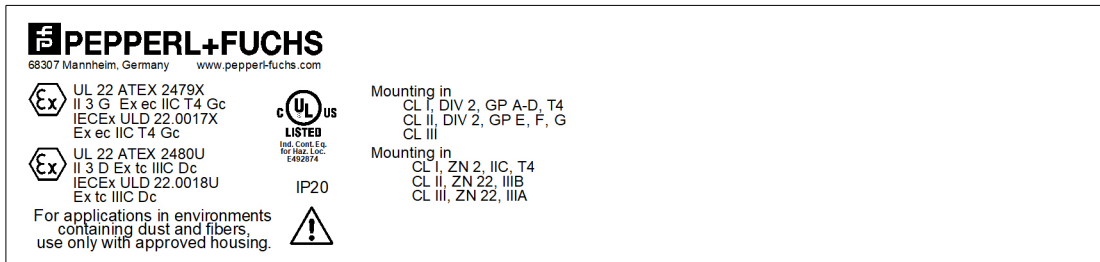

Figure 3.12

(6) Certification label CCC sample 10-CRF5



Figure 3.13



## 4 Mechanical Installation



### Note

The device is intended for indoor use. If placed in a suitable housing, the device can also be used outdoors. The specified operating temperature must be maintained in any case.

---



### Note

If the device is used in a manner not prescribed by the manufacturer, the built-in protective function of the device may be impaired.

---



### Note

Recommendation for use: Carry out the installation of the device at the installation location with at least two persons.

---

### 4.1 Unpacking



### Note

Handling the VisuNet FLX components without gloves may cut fingers, hands, or wrists. Wear gloves always during installation.

---

The VisuNet FLX panel comes with its core components preassembled. These components consist of a display unit (DPU) and a computing unit (thin-client unit (TCU), PC unit (PCU) or direct monitor unit (DMU)).



Figure 4.1

**Caution!**

Scratches and damage!

FLX components may become scratched or damaged if they are placed onto or slid across hard surfaces.

---

**Caution!**

Restrictions resulting from scratched DPU screen!

Scratches in the DPU screen weaken the glass structure. If the surface is damaged in any way, return the DPU to Pepperl+Fuchs at once and replace it with a new one. See chapter 7.2 for information about removing the DPU.

---

**Warning!**

Proper installation!

It is the installer's responsibility to select a suitable location with sufficient strength to hold the equipment. It is the installer's responsibility to select the proper screws based on the installation conditions.

---

**Warning!**

Proper sealing!

To assure proper sealing, the minimum wall thickness of 1 mm must be kept and it is necessary to use the horizontal and vertical brackets included in the kit for panel mounting. The maximum wall thickness for VisuNet FLX 21.5" panels is 3 mm, for 19" and 15.6" panels 4 mm.

---

## 4.2 Panel Installation

**Caution!**

Heat damage!

If the device is exposed to radiation from sunlight or other light or heat sources, it may overheat and be damaged.

Do not expose the device to direct sunlight or other sources of light or heat!

---

**Warning!**

The use of the device is only permitted under the environmental conditions (temperature, humidity, vibration and shock) which are specified in the data sheet.

Failure to observe any one of these conditions will invalidate the warranty of the device. Pepperl+Fuchs cannot be held liable for any damage arising from improper use and handling.

---

**Danger!**

Damage caused by condensation!

If the temperature of the device is different to that of the room in which it is located, condensation can occur.

Switch on the device only if it has acclimated to the ambient temperature!

---

**Danger!**

Danger resulting from damaged seals.

Explosion protection is no longer ensured if a system with damaged seals is used. NEVER use a system with damaged seals in a hazardous area. If the seal is damaged in any way, return the system to Pepperl+Fuchs at once and replace it with a new one.

---

### 4.3 General Installation Information

Observe the following requirements when installing the system components:

- The equipment must be installed by competent personnel in accordance with the instructions. National laws and regulations must be observed.
- The building installation must provide a 20 A overcurrent protection.
- The installer must make a readily accessible disconnect device available.
- Do not place the device next to other devices that might cause overheating.
- Keep the device away from arc-generating devices such as magnetic switches and non-fused breakers. Avoid using the device in environments where corrosive gases are present.
- To ensure an adequate air flow from natural convection install the VisuNet FLX in a location providing a minimum clearance of 50 mm (1.96 in.) or more on the left and right sides, 50 mm (1.96 in.) or more on the rear side, and 100 mm (3.93 in.) or more above and below the product from all adjacent structures and equipment.
- Install the device with sufficient clearance to provide for cable routing and cable connectors.

**Included with delivery:**

- Preassembled VisuNet RM-, PC- or DM- FLX Panel

**Items Ordered Separately:**

- Kit for Panel Mounting (2x horizontal brackets, 2x vertical brackets, incl. mounting nuts)

**Versions**

Item Number	Dimension	Item Name
70129836	21.5"	PM-KIT-3200-22-304-N0
70129837	19"	PM-KIT-3200-19-304-N0
70129838	15.6"	PM-KIT-3200-15-304-N0

### 4.4 Mounting the Panel in the enclosure



**Warning!**

Risk of injury!

Lifting the device on your own may lead to injury. Do not attempt to lift the device on your own. Use a crane or have another person help you.

Overheating of the system can result in improper behavior of the software. To avoid overheating the system, observe the following instructions:

- Make sure that the environmental characteristics of the system are observed.
- The BPC3200-\*/DMU3200-\* and the display may only be operated in closed rooms.
- The display must not be exposed to direct sunlight.
- The ventilation openings of the computing unit and the display unit must not be covered.
- When mounting the display, the permissible mounting angle must not be exceeded.



**Danger!**

Ambient conditions

Do not operate the device outside the specified ambient temperature.

- Ensure for the Panel mount option with additional Panel-Mount-Kit that the thickness of the installation panel is from 1 mm to 3 mm(0.06 inches to 0 inches).
- All installation panel surfaces used should be strengthened. Due consideration should be given to the weight of the VisuNet FLX panel, especially if high levels of vibration are expected and the installation panel can move. Use the brackets of the Panel Mount Kits, to increase the strength of the installation panel.
- Ensure that all installation tolerances are maintained.

- Ensure that the enclosure provides a flat surface area to confirm a proper sealing between panel and enclosure.
- Do not touch the touch screen during the startup of the operating system.
- Do not operate the unit when the surface of the touch screen is wet.
- If the surface of the touch screen is wet, remove the existing water with a soft cloth before resuming operation.
- Use only the approved equipotential bonding configuration specified in chapter 5.
- All nuts of the mounting brackets must be tightened with a torque of 4 Nm.

### Space Requirements

#### Circulation of air

To ensure adequate ventilation of the Panel, leave enough space around the Panel for air circulation.

Mount the Panel PC so that the spacing on the top, bottom, and sides is as follows:

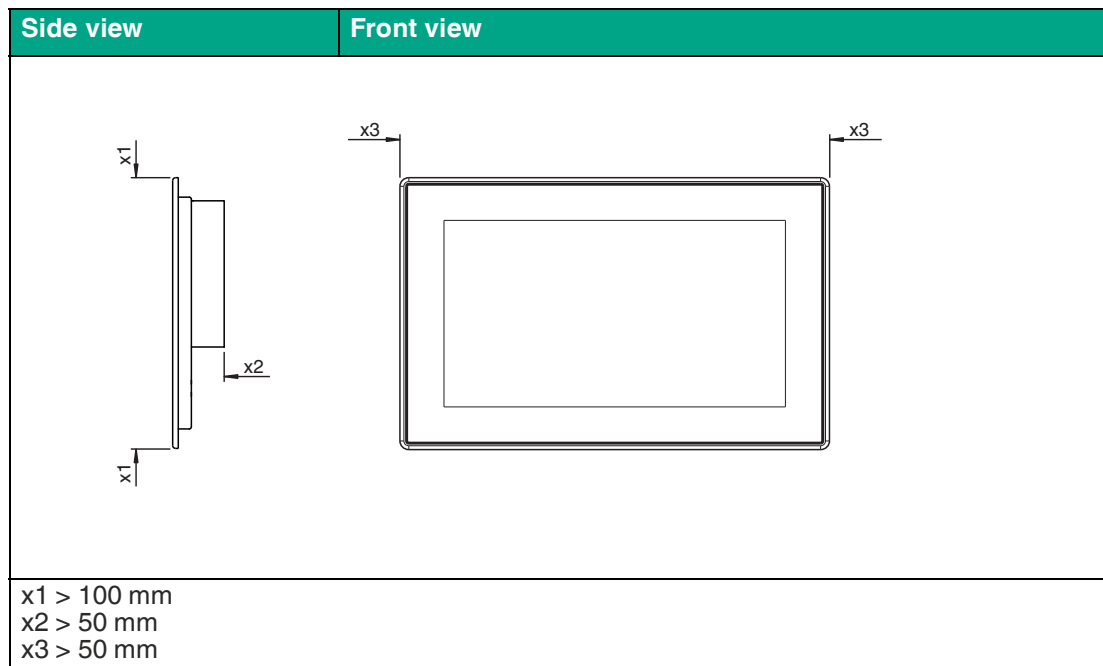

### Mounting Orientation

The following figure shows the allowable mounting orientation for the Panel PC:



Figure 4.2

The Panels 21.5", 19" and 15.6" can be mounted in a housing with the suitable cutout. This mounting is approved for the installation in Ex e, Ex p or Ex tb housing.

The VisuNet FLX Panel Mount option consists of the Display Unit with pre-mounted computing unit and sealing material. The sealing material is applied to the back of the Panel.



### Installing the Panel within an enclosure with the Panel Mount Kit

1. Cut a hole in the enclosure according to the dimensions of the selected display.

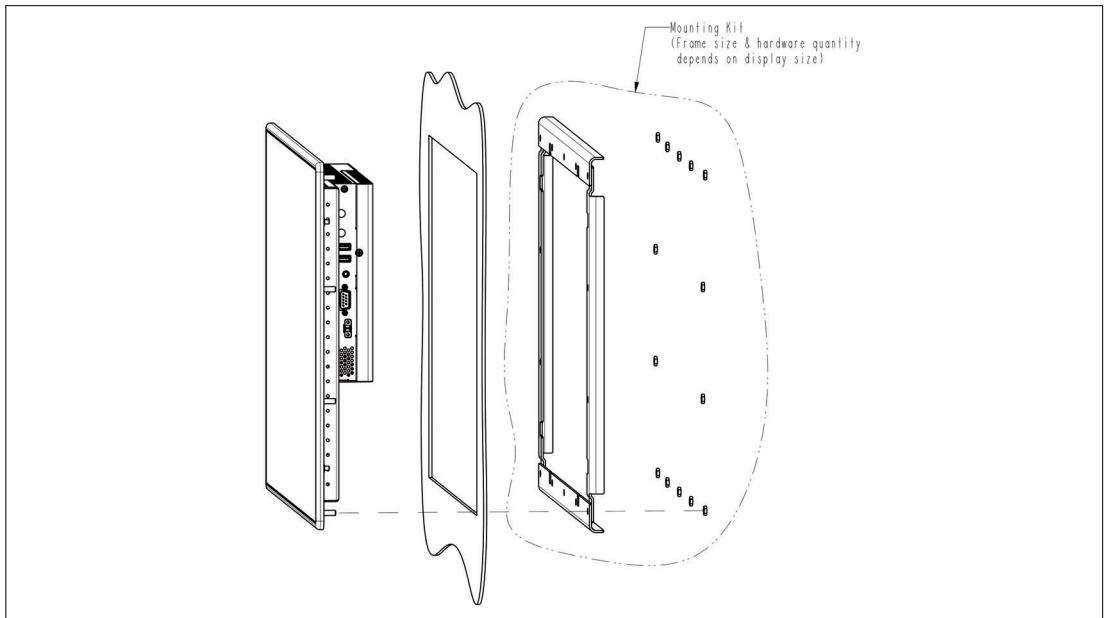

Figure 4.3

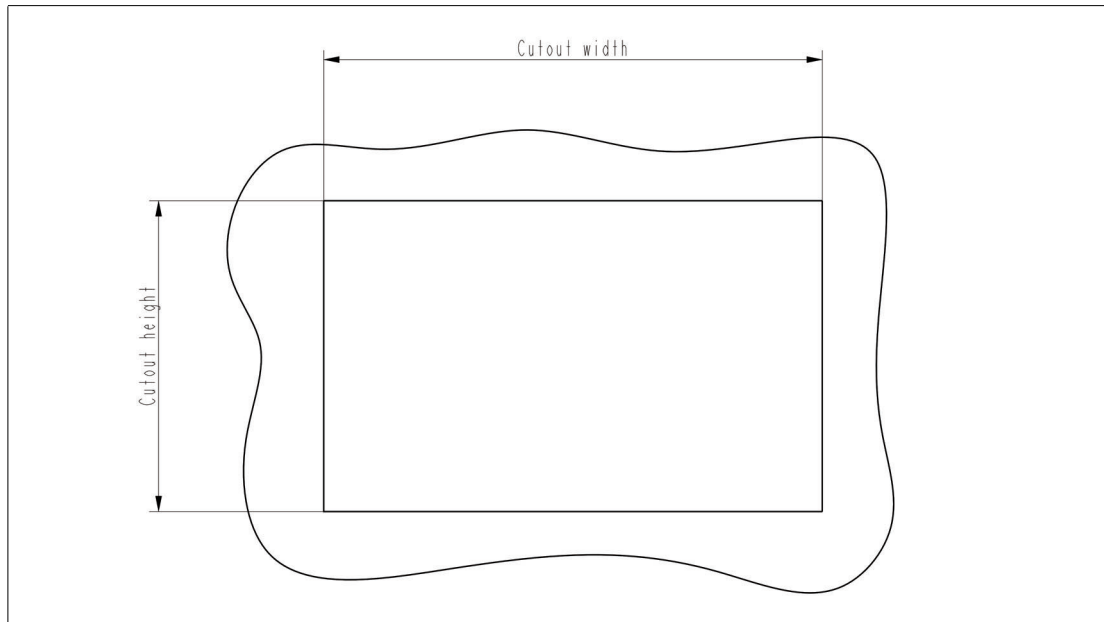

Figure 4.4

Display Size	Cutout width	Cutout height	Tolerance	Panel Mount Kit
21.5 "	535 mm (21.06 in)	333.5 mm (13.13 in)	+/- 1 mm	#70129836
19"	455 mm (17.91 in)	386 mm (15.2 in)	+/- 1 mm	#70129837
15.6"	401.5 mm (15.81)	259 mm (10.2 in)	+/- 1 mm	#70129838

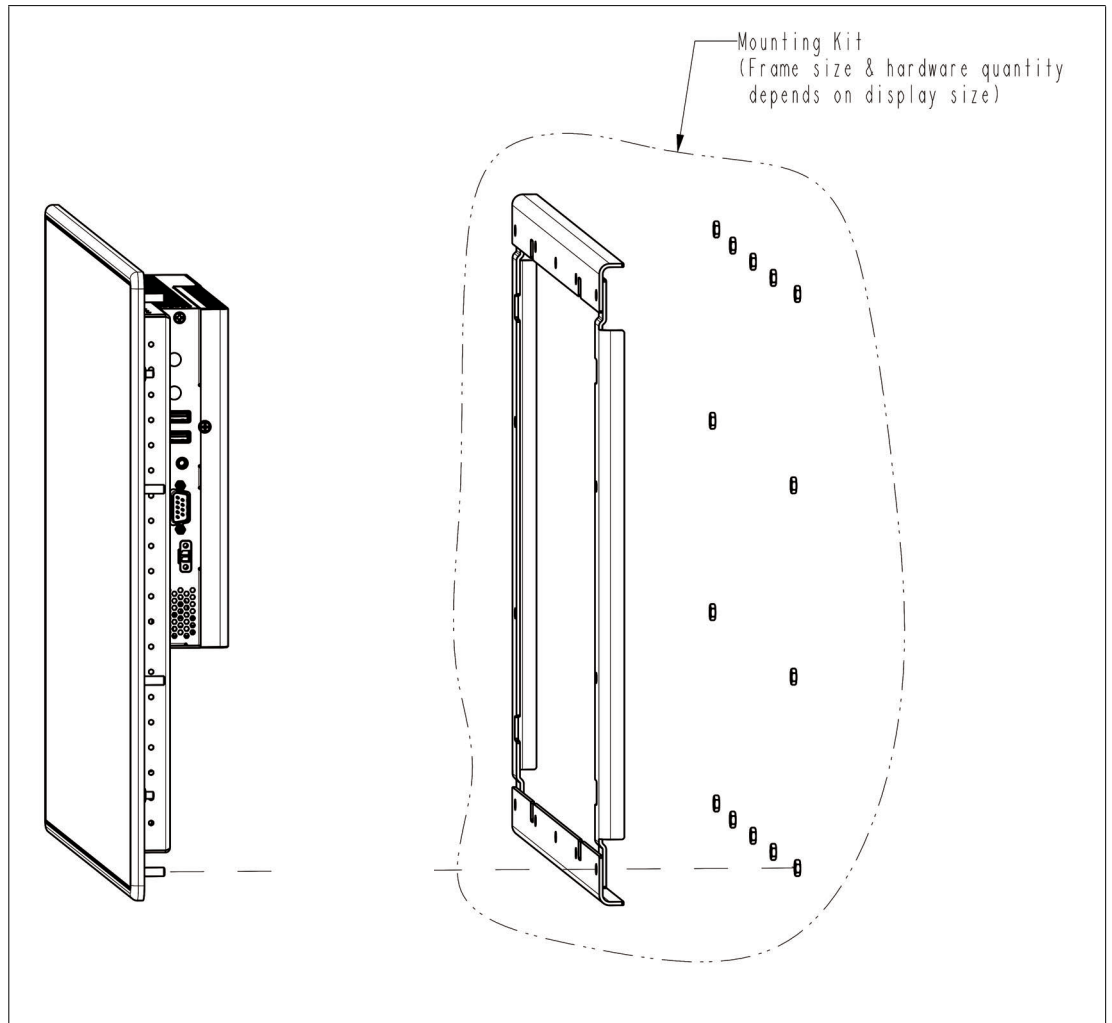

Figure 4.5

2. From the front, place the bottom edge of VisuNet FLX Panel in the opening. Tilt the top of the VisuNet FLX panel through the opening until the gasket connects smoothly to the enclosure. Ensure that the gasket is properly positioned in the groove and against the panel.
3. Hold on to the Panel from the front while placing the horizontal brackets from the back tighten them in a criss-cross pattern using a torque of 4 Nm.
4. Tighten the vertical brackets as well in a criss-cross pattern with a torque of 4 Nm.



## Installing the Panel using the drilling pattern



### Warning!

Wall panel thickness!

For the following installation a wall panel thickness of minimum 2 mm and maximum 4 mm is required for correct mounting.

For this installation no additional sales item is required.

### Not included in Panel Mount delivery but required:

21.5" and 19": 14x M5 nuts

15.6": 10x M5 nuts

1. Use the required VisuNet FLX as a template (or the dimensions shown in Figures below) and mark the locations of the holes on the mounting surface.
2. Securely attach the VisuNet FLX panel to the wall. Ensure that the attaching hardware is in the small section of the keyholes.
3. Fasten the nuts with a torque of 4 Nm each in a criss-cross pattern.

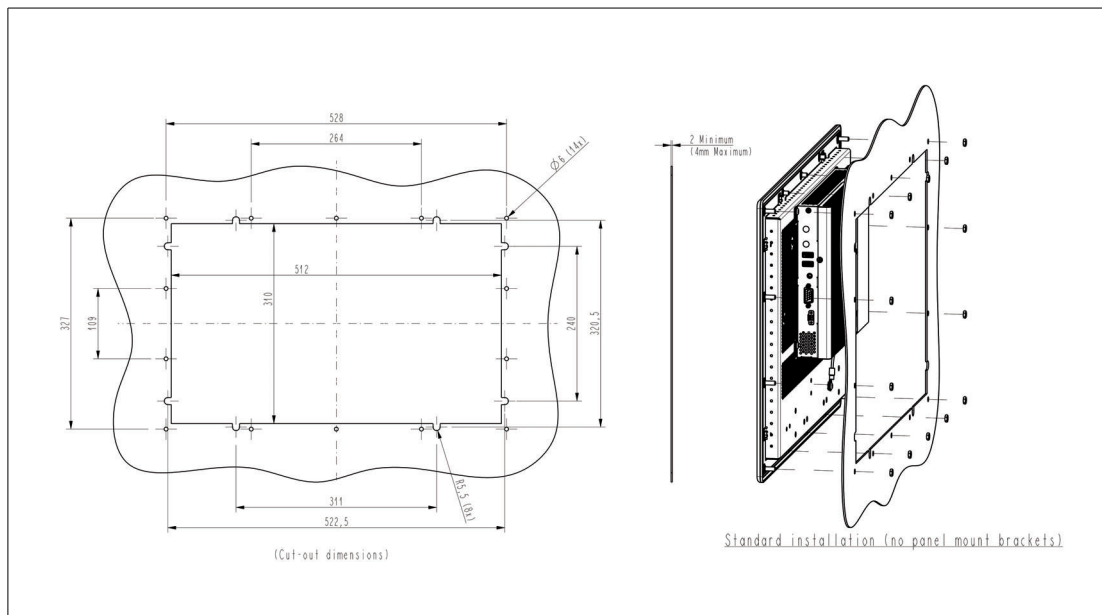

Figure 4.6 21.5" FLX Panel Mount



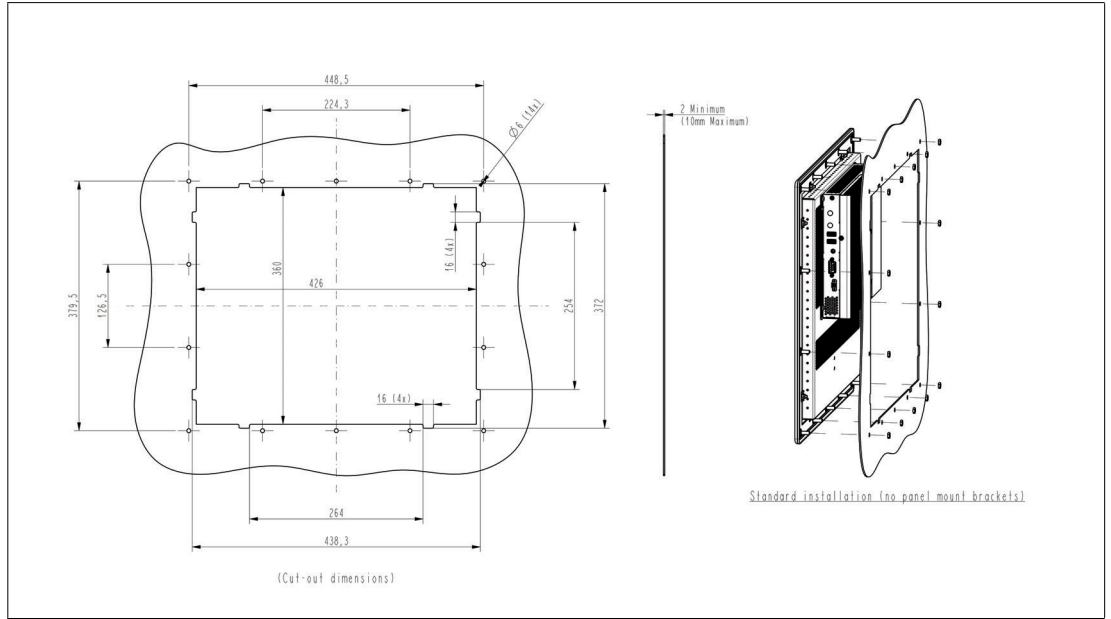

Figure 4.7 19" FLX Panel Mount

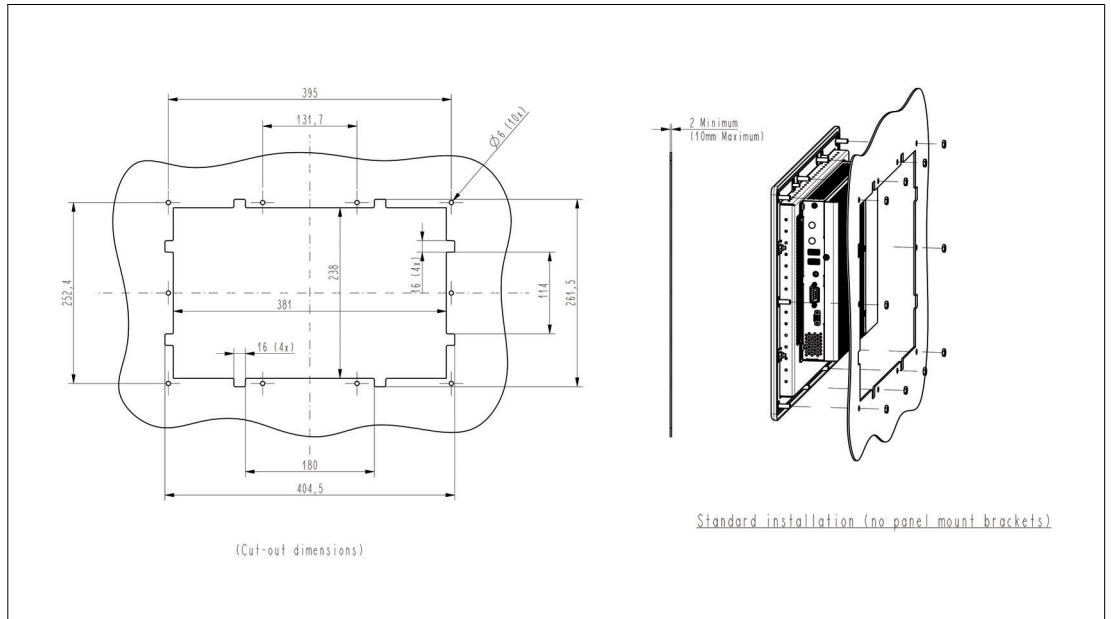

Figure 4.8 15.6" FLX Panel Mount

## 5 Electrical Installation



---

**Warning!**

Danger of explosion!

Cable insulation may become damaged if cables and connection lines are not used in adequate temperature ranges. Thus, short circuits within the cable may occur which in turn may give rise to sparks and/or surface temperatures capable of triggering an ignition. Only use cables and connection lines which are suitable to be used within a temperature rating of 80°C.

---



---

**Danger!**

Explosion hazard from wrong or missing equipotential bonding!

Wrong or missing equipotential bonding can cause sparks. This can ignite the surrounding potentially explosive atmosphere.

1. Connect the equipotential bonding of the device. Observe the equipotential bonding requirements.
  2. Ensure that external equipotential bonding connections exist, are in good condition, and are not damaged or corroded.
- 



---

**Warning!**

Risk of electric shock or property damage from inadequate equipotential bonding!

If you do not connect the equipotential bonding of the device correctly, this could result in potential equalization currents. These currents could hurt operating personnel or cause property damage. Connect the device via the equipotential bonding bolt. Ensure that a correct potential equalization is guaranteed always.

---

When installing the VisuNet FLX panel, always ensure a proper equipotential bonding with a cable diameter of at least 4 mm<sup>2</sup> in accordance with IEC 60079-14.

---



---

**Note**

Refer to the manuals of the individual VisuNet FLX components for more information on electrical installation and wiring.

---

## 5.1 Equipotential Bonding of the VisuNet FLX Panel

The VisuNet FLX is shipped with the following PB protective (equipotential) bonding wiring connection, if the panel mount option is selected:



### Warning!

PB protective equipotential bonding!  
PB protective equipotential bonding is mandatory.

PB wire from the computing platform housing PB stud to the pan head screw of the panel (1).  
Connection (2) has to be done by the end user.

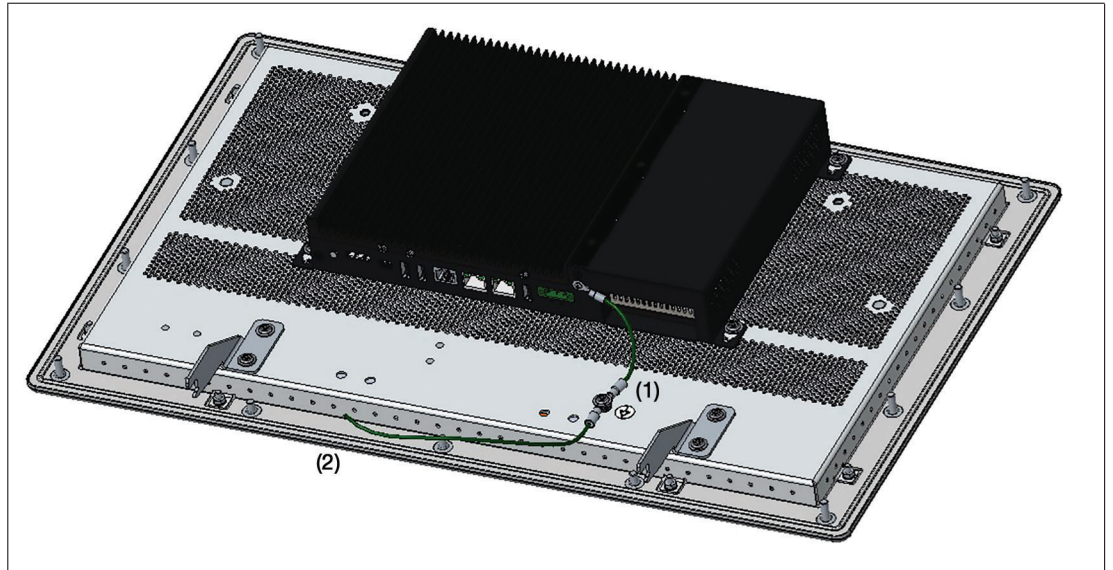

Figure 5.1 Connection (2) has to be done by the end user.

1. Connect the equipotential bonding of the housing with the PB stud on the backside of the Display Unit on the marked stud.
2. Fasten the hardware with a torque of 4.0 Nm.



### Warning!

Operator responsibility to verify PB protective equipotential bonding!  
Check the PB protective equipotential bonding after completing system installation.



### Warning!

Risk of personal injury and equipment damage!  
Pinched PB wire.  
Ensure that the PB wire does not become pinched between the panel and the enclosure.



### Warning!

Explosion hazard from wrong or missing protective equipotential bonding.  
Wrong or missing protective equipotential bonding can cause sparks. This can ignite the surrounding potentially explosive atmosphere.

1. Observe the protective equipotential bonding requirements.
2. Ensure that external protective equipotential bonding connections exist, are in good condition, and are not damaged or corroded.

If you replace the DPU, reestablish the PB connection in the same configuration. Tighten the PB hardware to 4.0 Nm and build up the equipotential bonding stackup as shown in the picture:

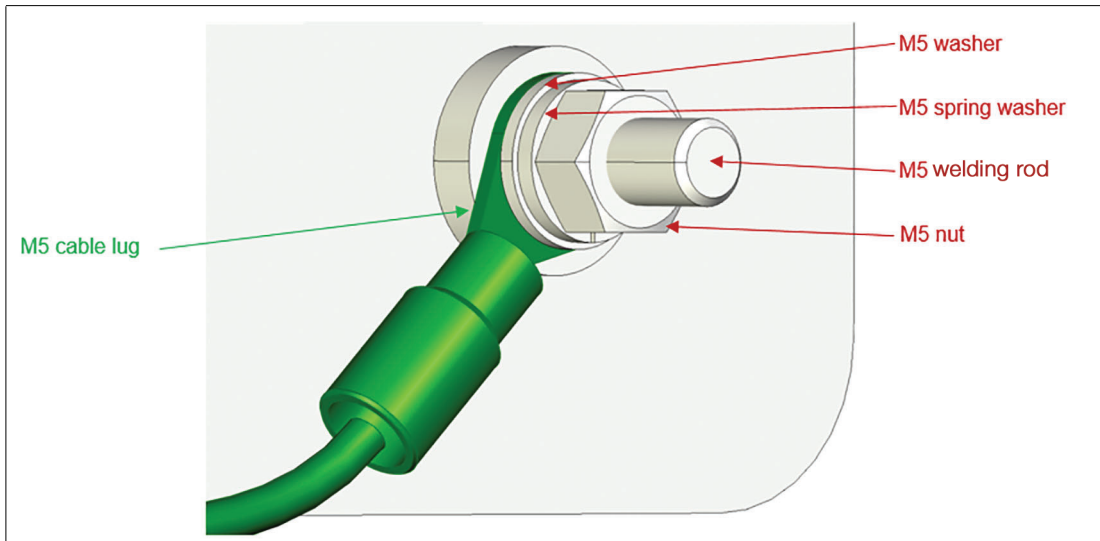

Figure 5.2

## 5.2 Power Connection



### Warning!

Hazard due to excessive current!

Excessive current can cause overloading of the electronics which could then result in injury or damage.

Operate the device with a power supply that complies with SELV/PELV or NEC Class 2!

### Connect the DC Power Cable



### Warning!

De-energize the equipment or disconnect the supply of the device before removing any covers or elements of the system, and prior to installing or removing any accessories, hardware, or cables.

Always use a properly rated voltage sensing device to confirm that power is off.

Replace and secure all covers or elements of the system before applying power to the unit.

Failure to follow these instructions result in death or serious injury.



### Wiring and Connecting the Terminal Block Field Input

1. A three-position, screw-type connector (MC311-500) is provided for connecting power to the VisuNet FLX panel.

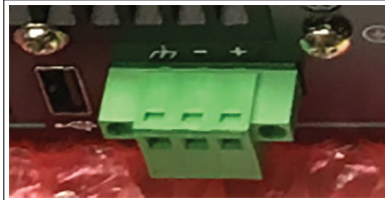



Figure 5.3 Power connector is included in the delivery.

2. Connect a power source to the included power connector.  
This connector supports wire size 4 mm<sup>2</sup> (~12-24 AWG). Torque the wire-retaining screws in the connector to 0.5 Nm to 0.6 Nm. Secure the connector to VisuNet FLX panel.

Pin No.	Allowed Cable Diameter
	16 ... 12 AWG (1.5 ... 4 mm <sup>2</sup> )
-	
+	

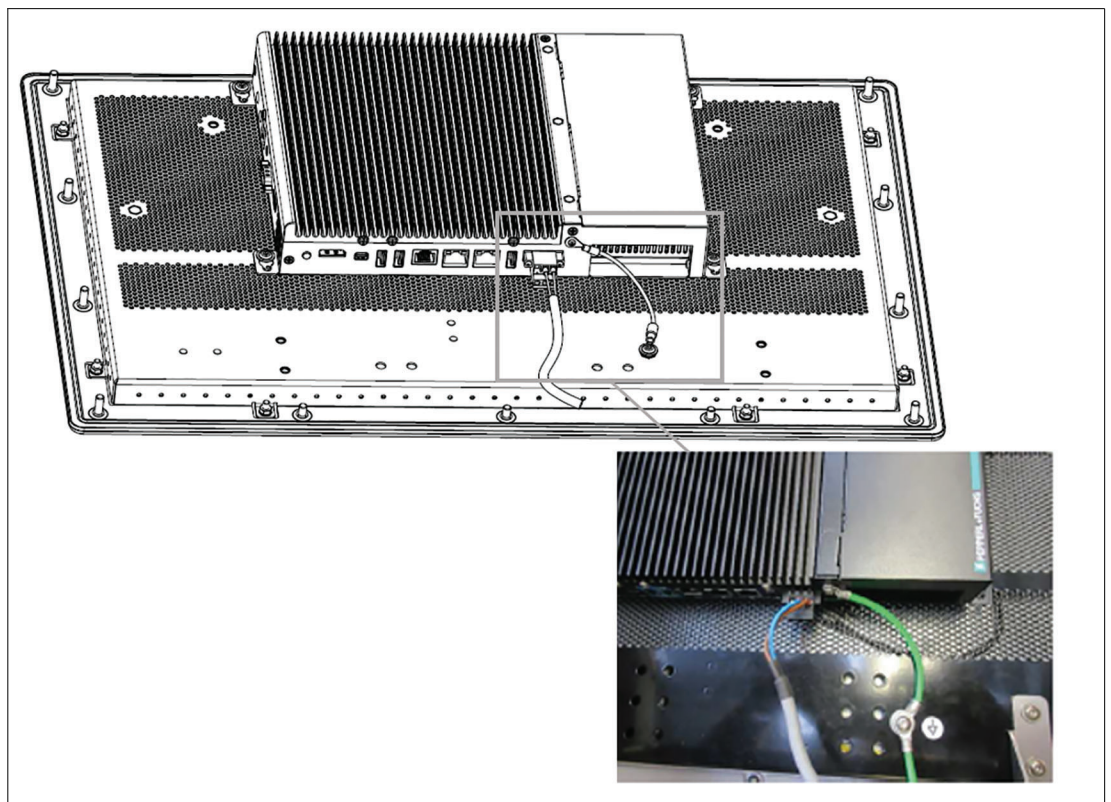

Figure 5.4

## 6 Interfaces



**Caution!**

Damage to the electronics!

The electronics can be damaged if plug-in connections are connected or disconnected while power is still being applied.

Make sure that no power is being applied while connecting and disconnecting cables!



**Warning!**

Interfaces must have a strain relief in Ex-operation.

This can be achieved with the ATEN Locks (#548400)

### 6.1 Computing Unit - Interface Connectors

For detailed information on the interfaces of the computing units refer to the BPC3200-\* manual or DMU3200-\* manual.

#### 6.1.1 Power Limitations



**Caution!**

Maximum allowed output currents!

It is necessary to consider maximum allowed output currents depending on the installation of the VisuNet FLX panel.

**Available output currents VisuNet FLX panel installation:**

Port	Panel
USB 2.0	500 mA
USB Ex-iPort A	100 mA
USB Ex-iPort B	100 mA
USB 3.0 Port A	800 mA
USB 3.0 Port B	800 mA
Serial Ports (shared)	200 mA



**Note**

Refer to the VisuNet FLX System manual and BPC3200-\* manual to get detailed information on the maximum output current of these installations.

The external circuits intended to be connected to this device shall be galv. separated from mains supply or hazardous live voltage by reinforced or double insulation and meet the requirements of SELV/PELV circuit of UL/CSA 61010-1.

## 7 Maintenance

All VisuNet FLX models perform a degree of thermal management to avoid overheating under heavy load.



---

### Note

Operating temperature has influence on the VisuNet FLX lifetime.

---



---

### Caution!

Use only approved spare parts.

The installation of spare parts not intended for the VisuNet FLX may damage the device, machine or system. The warranty is void if you install spare parts that are not permitted.

Only original service parts from P+F are allowed to be used.

---



---

### Warning!

When exchanging any components, it is mandatory to follow the single de-/installation steps!

---



---

### Warning!

Danger of Explosion

An ignition may be triggered if the TCU/PCU/DMU is still energized when its terminal compartment is opened. Turn off the TCU/PCU/DMU and wait 3 minutes after de-energizing before opening the terminal compartment.

---

## 7.1 Exchanging the BPC3200-\* or DMU3200-\*



### Procedure

If repairs or updates are required, the computing unit can be dismantled from the DPU and be replaced.



#### Note

Please refer to the individual component manuals regarding service and repair of the components.



#### Note

In case of an exchange of the BPC3200-\* the DIP switches need to be set correctly (Refer to the BPC3200-\* manual for detailed information on the DIP switch positions.)

1. Remove the panel if required. Place the unit on a soft, raised surface so that the front will not be damaged.
2. Remove the two PB conductors (1 and 2) from the PB stud on the back of the DPU.

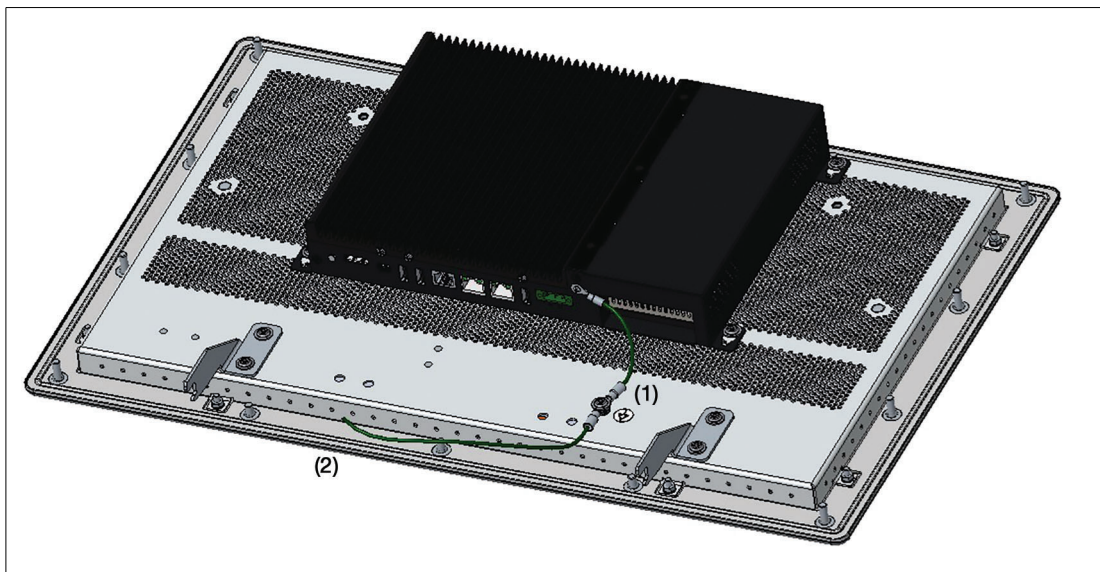

Figure 7.1



3. Open the side cover of the BPC3200-\* in case of a DMU3200-\* remove the cover plate.

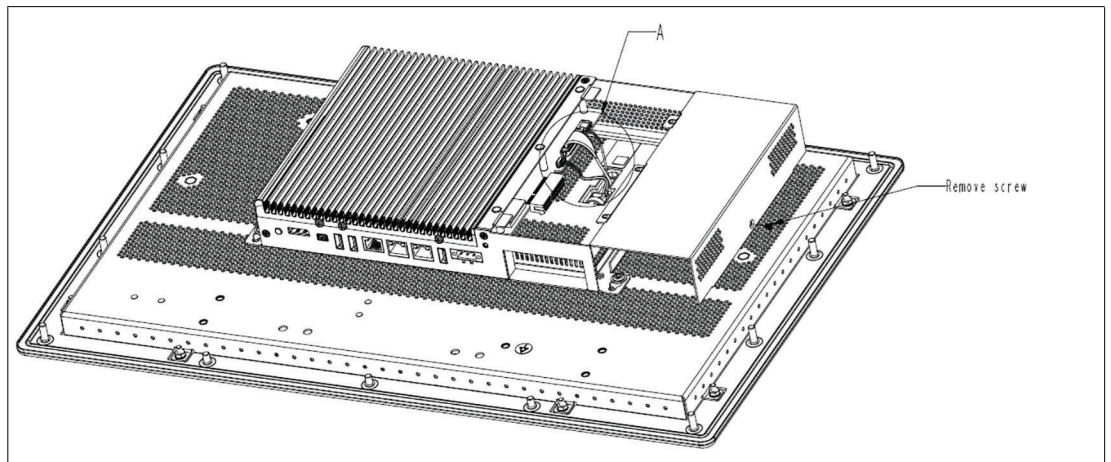

Figure 7.2 Remove the screws and open the side cover.

4. Remove the pins (USB-Touchscreen signal, LVDS-video signal and Inverter LCD backlight) from the sockets of the DPU. Make sure to pull all the side tabs of the connectors evenly and smooth.



**Note**

Make sure to pull the side tabs of the connectors. Pulling on the wires can cause the pins to be removed from the connectors, especially with small wires and contacts that are found on the LVDS cable. (See graphics "Remove connectors [1]" and Remove connectors [2])

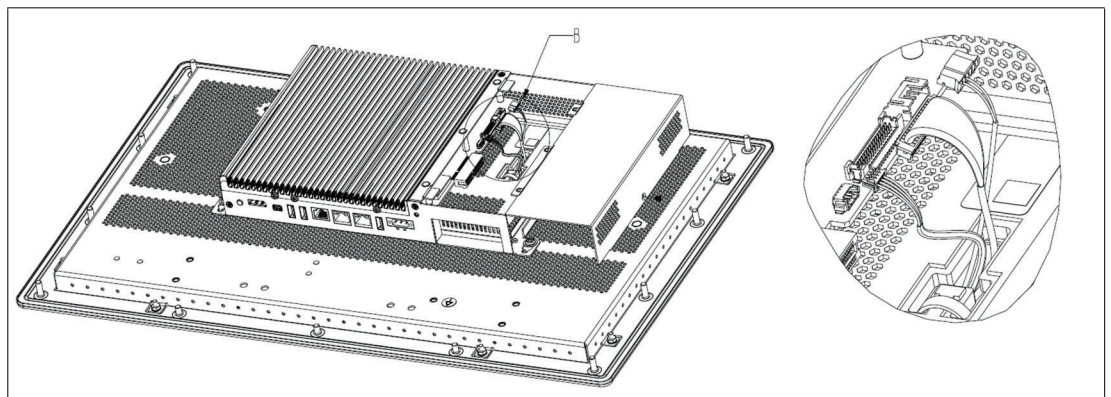

Figure 7.3 Opening the BPC cover (A: USB-Touchscreen signal, LVDS-video signal and Inverter LCD backlight pins)



**Note**

Pull all cables evenly. Use slightly more force on the LVDS connector (not the cable!).

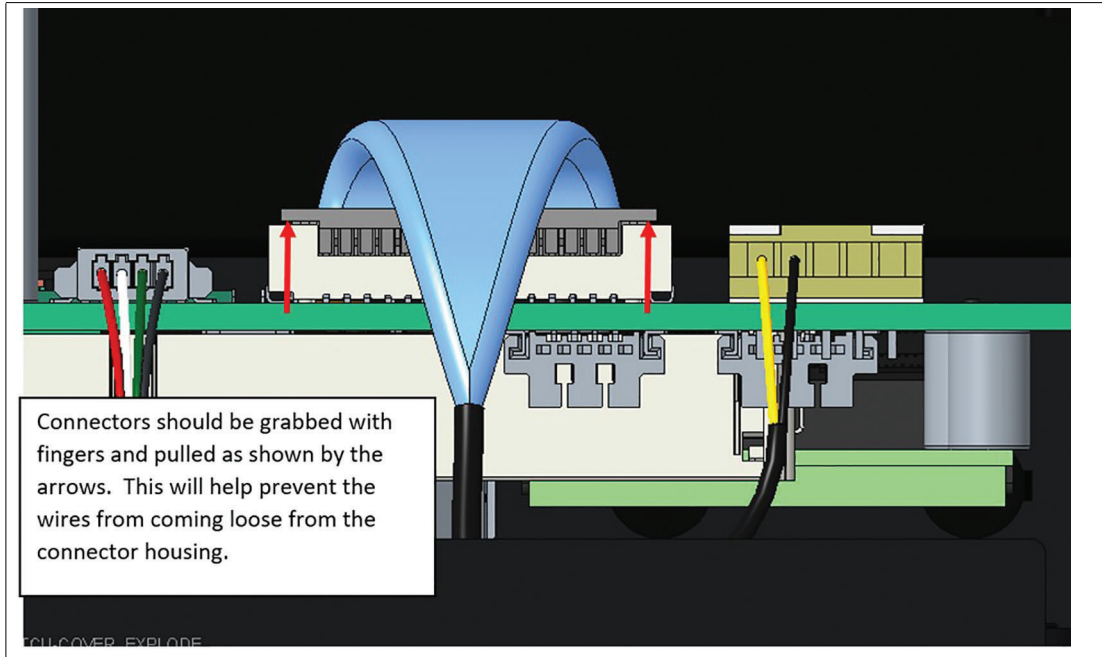

Figure 7.4 Remove connectors [1]

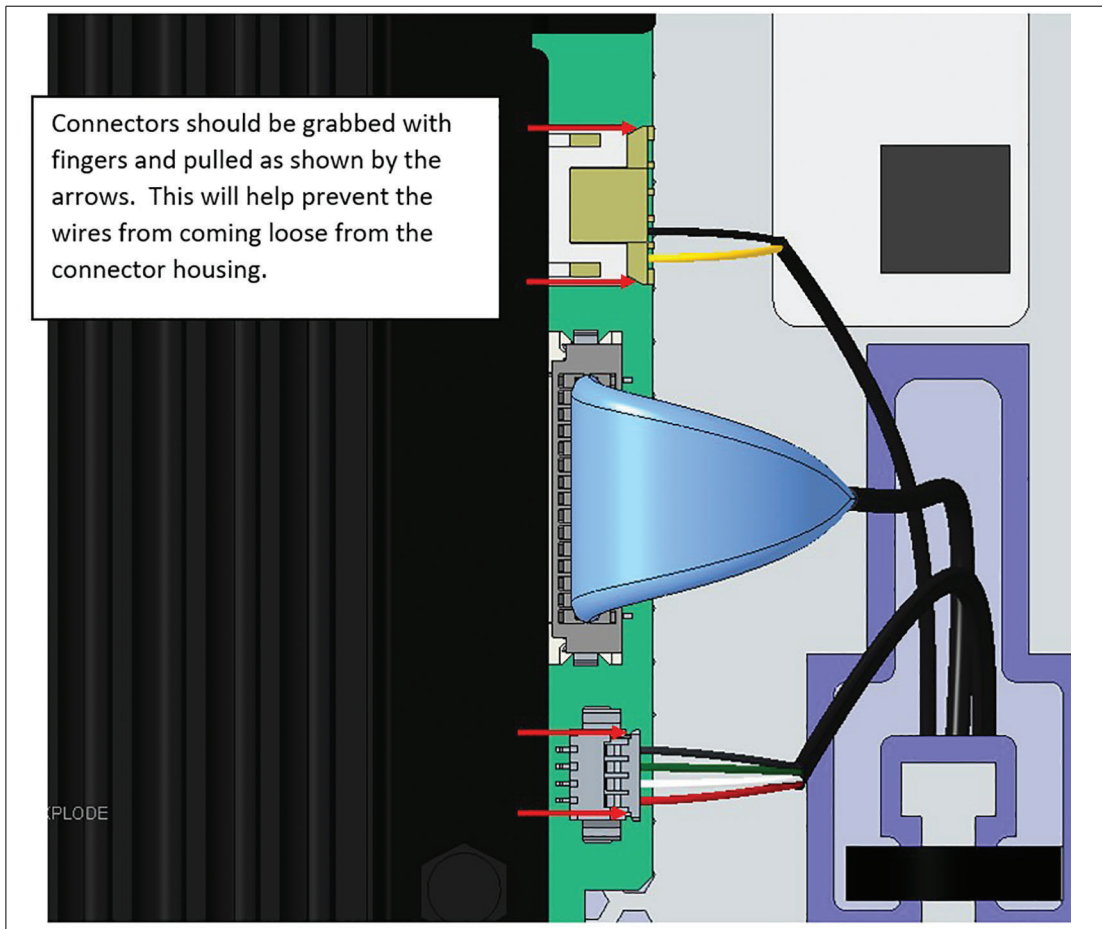

Figure 7.5 Remove connectors [2]



Figure 7.6

5. Remove the four screws that connect the computing unit to the DPU and remove the old computer unit from the DPU.
6. Now the steps continue with your new device. If you are exchanging a BPC3200-\*, open the side cover first. Remove all four screws from the back of the computing unit and take it off the computing unit (2).

7. **These installation steps are only relevant when installing a new BPC3200-\***
8. To configure the screen resolution set your DIP switches correctly (Refer to the BPC3200-\* manual for detailed information on the DIP switch positions.)
9. In case you want to operate the serial interface ports in any other mode than RS-232 configure your serial ports by setting your Jumpers correctly and adjusting the settings in BIOS. Refer to the BPC3200-\* Manual for further information on the serial port configuration.
10. Leave the side cover of your BPC3200-\* open/open the rear cover of your DMU3200-\*.
11. Orient the computer unit to the screw holes to be mounted. Guide the cables of the DPU through the opening provided.
12. Push the computing unit up to the top of key holes. Use a torque of 4 Nm for tightening the four screws of the computer unit. (See graphic "Assembling")

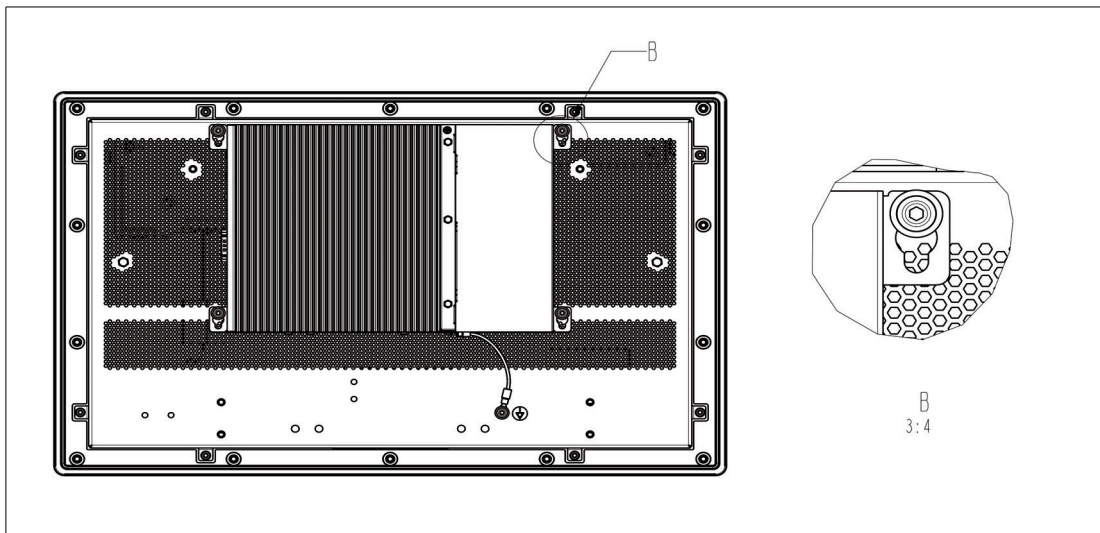

Figure 7.7 Assembling



**Note**

When mounting back the BPC3200-\* or DMU3200-\* to the DPU, push all the way down - leave no clearance at the top of the screw bracket.

13. Connect the USB, LVDS and LED inverter cable back to the computing unit.

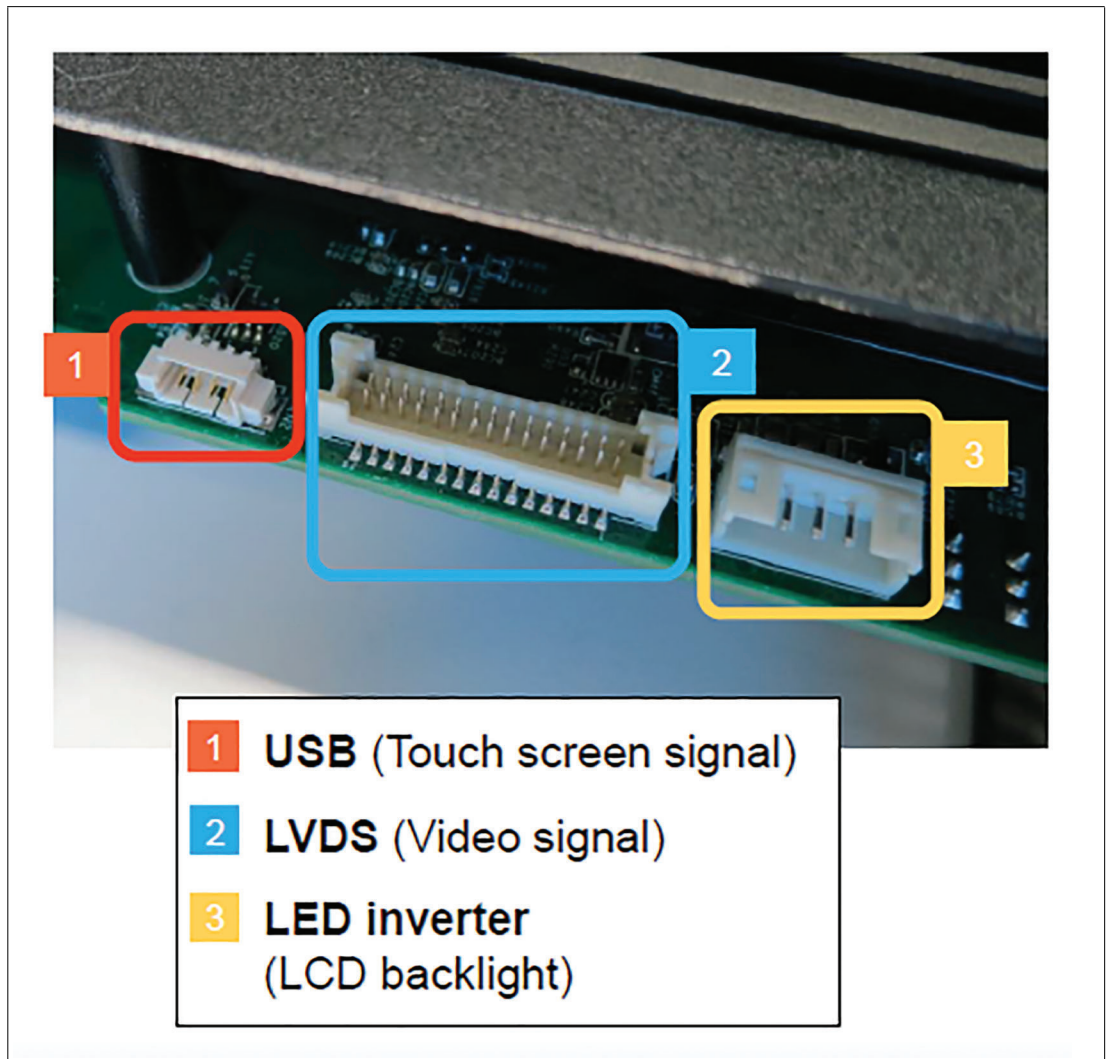

Figure 7.8

14. Close the cover of the computing unit
15. If required mount your VisuNet FLX panel.

## 7.2 Dismounting the Display Unit



If repairs are required, the DPU can be dismounted from the BPC3200-\* / DMU and be replaced.

1. Uninstall the Panel from the enclosure. When the Panel-Mount Kit is used, remove the four brackets while holding on to the panel so it might not flip over. Remove the panel. Place the unit on a soft, raised surface so that the front will not be damaged.
2. Follow steps 2 to 5 of chapter **Exchanging the BPC3200-\* or DMU3200-\***.
3. Leave the side/back cover of your computing unit open.
4. Exchange the display unit.
5. Follow steps 9 to 13 of the chapter **Exchanging the BPC3200-\* or DMU3200-\***.

### Back view of the display unit without computing unit

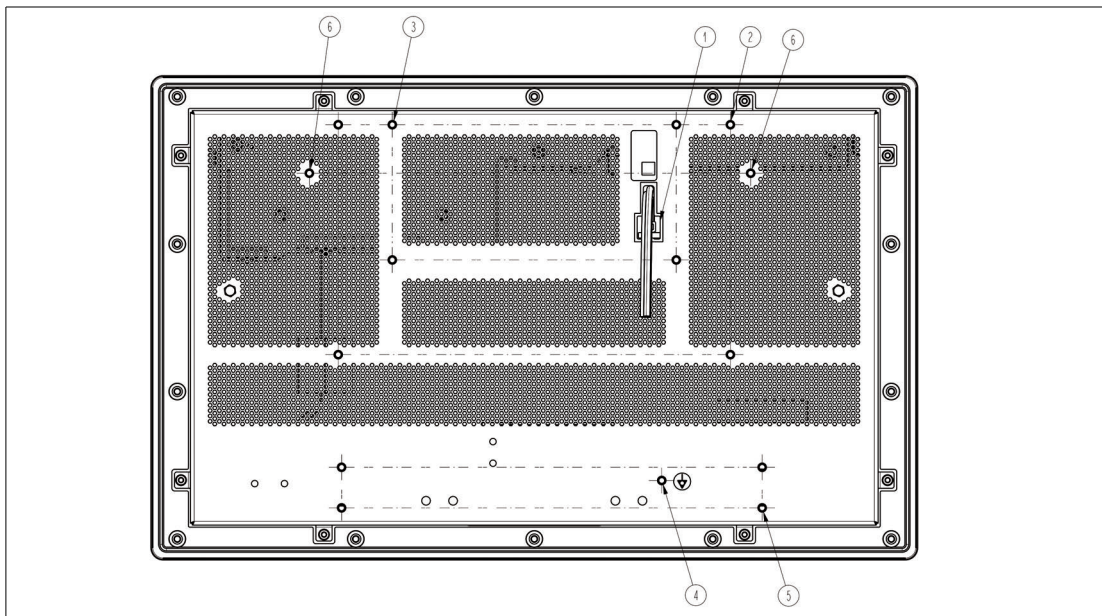

Figure 7.9

### Back view of the display unit without computing unit

No.	Item
(1)	Connector computing unit (USB-Touchscreen signal, LVDS-video signal and Inverter - LCD backlight)
(2)	Mounting holes to fix the BPC3200-*
(3)	Mounting holes to fix the DMU3200-*
(4)	Equipotential bonding Bolt
(5)	Mounting holes to fix the Hooks for System installation
(6)	Mounting holes for fixing the safety lines for System installation

### 7.3 Support Pixel Errors

With current LCD technology, a panel may contain a limited number of missing or flickering pixels.

Pepperl+Fuchs display units are tested according to internationally recognized standards in order to fulfill the tolerated pixel errors.

The following pixel errors in the LC display are due to production and do not represent a reason for complaint:

#### 21.5" Displays

##### Non-optical bonded 21.5" Display (22GT-)

Inspection Item		Specification
Display failure (V-line, H-line, Cross line etc.)		Not allowable
Bright dots	Random	≤ 2 dots
	2 dots adjacent	≤ 1 dot
Dark dots	Random	≤ 5 dots
	2 dots adjacent	≤ 2 dots
Total bright and dark dot		≤ 5 dots

##### Optical bonded 21.5" Display (22FC-)

Inspection Item		Specification
Line defects		Not allowed
Bright dots	Random	≤ 1 dots
	2 dots adjacent	≤ 0 dots
Dark dots	Random	≤ 5 dots
	2 dots adjacent	≤ 2 dots
Total bright and dark dot		≤ 5 dots

#### 19" Displays

Inspection Item		Specification
Line defects		Not allowed
Bright dots	Random	≤ 2 dots (Note 1 & 2)
	2 dots adjacent	≤ 1 dot
Dark dots	Random	≤ 3 dots (Note 1)
	2 dots adjacent	≤ 1 dots
Total bright and dark dot		≤ 5 dots



**Note**

**Note 1)**

A dot is defined as the defective size larger than 1/2 area of a subpixel. A small dot defect, defined as the defective size equal or smaller than 1/2 area of a subpixel, should be ignored.



**Note**

**Note 2)**

Bright dot should be accepted if N=2 which is visible through 5% ND filter. Press dot should be ignored if it will disappear after releasing external pressure.

## 15.6" Display

Inspection Item		Specification
Display failure (V-line, H-line, Cross line etc.)		Not allowable
Bright dots	Random	≤ 2 dots
	2 dots adjacent	≤ 1 dot
Dark dots	Random	≤ 3 dots
	2 dots adjacent	≤ 1 dot
Total bright and dark dot		≤ 5 dots

## 7.4 Gloves Tested for Touch Sensitivity

This section lists selected gloves and their touch sensitivity with the capacitive touch screen. This test was conducted by Pepperl+Fuchs.



### Warning!

It is the end user's responsibility to choose appropriate gloves.

The below list is not exhaustive, and it only deals with touch sensitivity. The ratings do not indicate, for example, whether a glove has chemical resistance.



### Note

To improve the touch detection rate with gloves, touch with the flat side of your finger and not with your finger tip.



### Note

The sensitivity of a RM-320P-\* based system touch screen can be configured in the VisuNet RM Shell. The sensitivity of a PC-320P-\*-based system touch screen can be configured with the Windows® tool.

### Rating Scale

Scale	Description
+++	High touch sensitivity easy to operate the touch screen.
++	Some touch sensitivity, possible to operate the touch screen.
+	Little touch sensitivity, difficult to operate the touch screen.

The following gloves have been tested for use with the display unit.

### Latex Gloves

Product	Rating 21.5" standard (22GT)	Rating 21.5" optical bonded (22FC)	19"	15.6"
KCL Butoject Art. 898	+++	+++	+++	+++
Marigold Industrial EMPEROR ME107	+++	+++	+++	+++
EKASTU 628	+++	+++	+++	+++
NITRITEC 7840-10	+++	+++	+++	+++
COMASEC SOLVA PLUS 0.5	++	++	+++	+++



**Cotton Gloves**

Product	Rating 21.5" standard (22GT)	Rating 21.5" optical bonded (22FC)	19"	15.6"
KCL Thermoplus Art. 955	++	++	+	+
UVEX C300 DRY	++	+++	+++	+++
Generic cloth glove	+++	+++	+++	+++
UVEX UNIDUR	+++	+++	+++	+++

**Leather Gloves**

Product	Rating 21.5" standard (22GT)	Rating 21.5" optical bonded (22FC)	19"	15.6"
Worky Schweisser Typ 1710	+++	+++	+++	+++
Adler-5	++	+++	+	+
Resista 10 Super	++	+	+	+

**7.5**

**Cleaning**

How often you must clean the system depends on your work and the operating environment. If necessary, follow the on-site cleaning plan.

Clean and maintain your system regularly.

**Cleaning agents and disinfectants**

The display unit consists of a chemically strengthened front glass and stainless steel bezel. The chemical resistance of the sealant between the glass and bezel was specified by the sealant manufacturer. Pepperl+Fuchs also tested the resistance of the sealant and the resistance of the gasket between the bezel and the housing.



**Note**

For detailed information regarding the chemical resistance of our VisuNet FLX materials please refer to our VisuNet FLX System manual. Here you find the results of immersion tests with common cleaning agents.

## 8 Accessories

### Replacement Components

Item No.	Type Code	Description
70128300	DPU3200-22GT-304A-V1-N0	Display Unit 21,5" Display (Full HD) Display option "22GT" with capacitive touch screen
70128301	DPU3200-22FC-304A-V1-N0	Display Unit 21,5" Display (Full HD), optically bonded Display option "22FC" with capacitive touch screen
Needs to be configured	BPC3200-*	Box PC BPC3200-* can be individually configured
70128304	DMU3200-22GT-V1-N0	Direct Monitor Unit DMU Compatible with Display option "22GT"
70128305	DMU3200-22FC-V1-N0	Direct Monitor Unit DMU Compatible with Display option "22FC"
70128306	DMU3200-19SC-V1-N0	Direct Monitor Unit DMU Compatible with Display option "19SC"
70128307	DMU3200-15FC-V1-N0	Direct Monitor Unit DMU Compatible with Display option "15FC"

# Your automation, our passion.

## Explosion Protection

- Intrinsic Safety Barriers
- Signal Conditioners
- FieldConnex® Fieldbus
- Remote I/O Systems
- Electrical Ex Equipment
- Purge and Pressurization
- Industrial HMI
- Mobile Computing and Communications
- HART Interface Solutions
- Surge Protection
- Wireless Solutions
- Level Measurement

## Industrial Sensors

- Proximity Sensors
- Photoelectric Sensors
- Industrial Vision
- Ultrasonic Sensors
- Rotary Encoders
- Positioning Systems
- Inclination and Acceleration Sensors
- Fieldbus Modules
- AS-Interface
- Identification Systems
- Displays and Signal Processing
- Connectivity

### Pepperl+Fuchs Quality

Download our latest policy here:

[www.pepperl-fuchs.com/quality](http://www.pepperl-fuchs.com/quality)

