

K23-SSI/USB/25B-C

Signal converter

Manual



The latest version of the General Terms of Supply for Products and Services in the Electronics Industry set out by the German Electrical and Electronic Manufacturers' Association (ZVEI) and the "Extended Reservation of Proprietorship" supplementary clause apply to this document.

Table of Contents

1.	Safety and Responsibility	5
1.1	General Safety Information.....	5
1.2	Intended Use	5
1.3	Installation	6
1.4	EMC Guidelines	6
1.5	Cleaning, Care, and Maintenance Instructions	7
2.	General Information.....	8
2.1	Operating Modes.....	8
2.2	Function Diagram	8
2.3	Power LED / Error Messages	8
3.	Electrical Connections	11
3.1	DC Voltage Supply (X1).....	11
3.2	Auxiliary Voltage Output (X2)	11
3.3	Incremental Rotary Encoder Input (X2).....	12
3.4	Absolute Rotary Encoder Input (X2)	14
3.5	Start/Stop Encoder Inputs (X2).....	16
3.6	Control Inputs (X3)	17
3.7	Parallel output (X5) / COM + (X3).....	18
3.7.1	Output „Error“.....	18
3.7.2	Output “Data stable”.....	18
3.8	Serial Interface (X4).....	19
4.	Operating Software OS6.0.....	20
4.1	General Menu.....	22
4.2	Frequency Mode	24
4.3	Counter Mode.....	30
4.4	SSI Mode	32
4.5	Start/Stop Mode	35
4.6	Serial Menu	38
4.7	Parallel Menu	42
4.8	Command Menu	44
4.9	Linearization Menu	46
5.	Appendix	47
5.1	Reading Out Data via Serial Interface.....	47
5.2	Parameter List / Serial Codes	48
5.3	Serial Codes of the Commands	54
5.4	Linearization.....	54
5.5	Reading in the SSI Value.....	57

5.6	Operating Modes / OP Modes of the Start/Stop Interface.....	61
5.7	Dimensions	63

1. Safety and Responsibility

1.1 General Safety Information

This description is an essential part of the device and contains important information regarding installation, function and use. Failure to observe these instructions may result in damage or impair the safety of people and attachments.

Please read this description carefully and observe all safety and warning messages before commissioning the device for the first time. Keep this description for future reference.

A prerequisite for using this device description is that the relevant personnel have the appropriate qualifications. The device may be installed, configured, commissioned and maintained only by a trained electrician.

Exclusion of liability: The manufacturer is not liable for any personal injury or property damage that may occur as a result of improper installation, commissioning, use or servicing, or due to human misinterpretations or errors within this device description. In addition, the manufacturer reserves the right to make technical changes to the device or description at any time without prior notice. Therefore, possible discrepancies between the device and the description cannot be ruled out.

The safety of the plant or of the overall system in which this device is integrated is the responsibility of the installer of the plant or the overall system.

All general, country-specific, and application-specific safety regulations and standards must be observed and followed during installation, operation, and maintenance work.

If the device is used in processes in which a possible failure or incorrect operation can result in damage to the plant or personal injury, appropriate precautions must be taken to ensure that such consequences are safely prevented.

1.2 Intended Use

This device is intended for use in industrial machinery and plants only. Any other use is not deemed to be in compliance with the provisions and is solely the responsibility of the user. The manufacturer is not liable for damage caused by improper use. The device may only be installed in the correct manner and be used and operated in a technically perfect condition—in accordance with the technical data. The device is not suitable for explosion-protected areas or in areas of application not included in DIN EN 61010-1.

1.3 Installation

The device may only be installed and operated in an environment that meets the permissible temperature range. Adequate ventilation must be ensured and the device must not have any direct contact with hot or aggressive gases or liquids.

The unit must be disconnected from all voltage sources prior to installation and before any maintenance work. It must also be ensured that no further danger can arise from touching the disconnected voltage sources.

Devices that are supplied with AC voltage may only be connected to the low-voltage network via switches or circuit breakers. This switch must be positioned close to the device and must have a marking that identifies it as a disconnecter.

Input and output cables for extra-low voltages must be separated from dangerous, current-carrying cables by means of double or reinforced insulation (SELV circuits).

All cables and insulation selected must correspond to the intended voltage and temperature range. Device and country-specific standards must also be observed, which apply to the cables in terms of design, shape, and quality. For information on permissible cable cross sections for the screw terminal connections, refer to the technical data.

Before commissioning, all connections and cables must be checked for a solid fit in the screw terminals. All screw terminals (including unused ones) must be screwed in as far as they will go to ensure that they are securely fastened and cannot come loose in the event of mechanical vibrations.

Overvoltages at the connections to the device must be limited to the values of the gas group II overvoltage category.

The general standards for switch cabinet construction in the machinery industry and the manufacturer's specific shielding regulations apply with regard to installation, wiring, ambient conditions, and shielding and grounding of supply cables.

1.4 EMC Guidelines

This device is designed to provide high protection against electromagnetic interference. Nevertheless you must minimize the influence of electromagnetic noise to the device and all connected cables.

Therefore the following measures are mandatory for a successful installation and operation:

- Use shielded cables for all signal and control input and output lines.
- Cables for digital controls (digital I/O, relay outputs) must not exceed a length of 30 m and are allowed for in building operation only

- Use shield connection clamps to connect the cable shields properly to earth
- The wiring of the common ground lines must be star-shaped and common ground must be connected to earth at only one single point
- The device should be mounted in a metal enclosure with sufficient distance to sources of electromagnetic noise.
- Run signal and control cables apart from power lines and other cables emitting electromagnetic noise.

1.5 Cleaning, Care, and Maintenance Instructions

To clean the front, use only a soft, slightly damp cloth. No cleaning work is intended or required for the rear of the device. Unscheduled cleaning is the responsibility of the competent maintenance personnel or the relevant technician.

During normal operation, the device does not require any maintenance procedures. In the event of unexpected problems, errors or malfunctions, the device must be sent to the manufacturer to be checked and repaired if necessary. Unauthorized opening and repair can result in impairment or even failure of the protective measures supported by the device.

2. General Information

The device is designed as a signal converter with control inputs, which converts the corresponding sensor or encoder information into a parallel signal. It is also possible to convert serial data to a parallel format. Its extensive functions and operating modes make it universally applicable.

2.1 Operating Modes

In general, all functions must be configured in the parameter menu. The device can be used in the following operating modes:

- Operation as a frequency converter for incremental input signals
- Operation as a position converter/counter for incremental input signals
- Operation as an absolute value converter for SSI signals
- Operation as absolute value converter for signals of a start-stop interface

2.2 Function Diagram

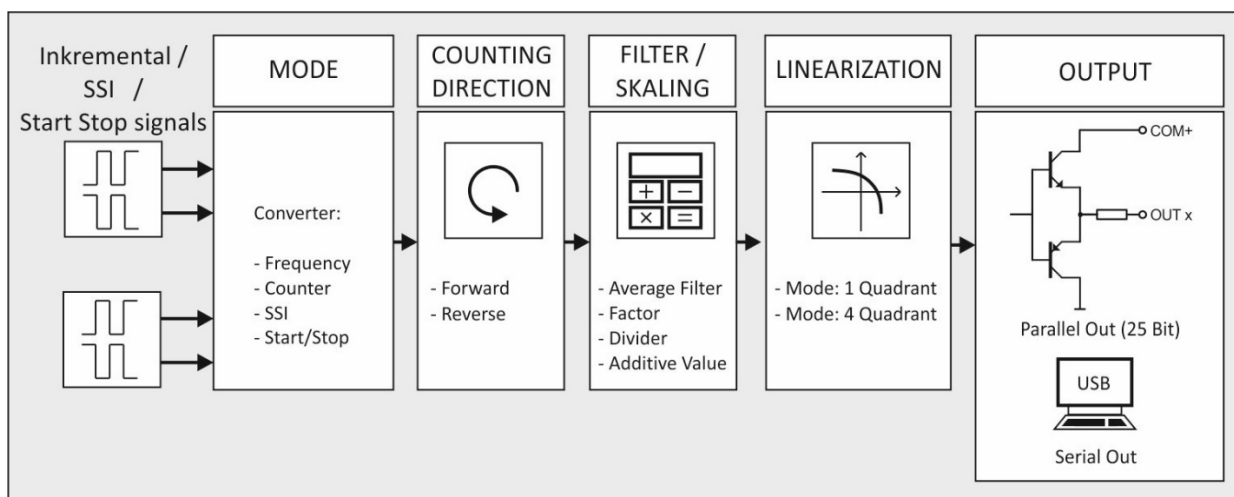

2.3 Power LED / Error Messages

The device has a green LED on the front film. This lights up continuously as soon as the supply voltage of the device has been established. If an error occurs, the LED flashes in a 1-Hz cycle. The analog output is also modulated with 0 V or 0/4 mA. When there is no longer an error, the LED automatically lights up continuously again and the analog output reacts once more to the result currently pending.

The exact error can be read out on the user interface (OS 6.0) via the serial interface. (→ Variable: Error_Status, Code: ";3"). See Chapter 4.

The individual error codes are explained in more detail below:

Error code (Error_Status)	Error name	Error description
0x00000001	Maximum Value	<p>SPECIAL PIN FUNCTION "Data-Bit / Data-Bit": Measured value is greater than + 16777215 ($2^{24}-1$)</p> <p>SPECIAL PIN FUNCTION "Error" or "Data – Stable": Measured value is greater than + 8388607 ($2^{23}-1$)</p> <p>SPECIAL PIN FUNCTION "Error" and "Data – Stable": (or negated accordingly) Measured value is greater than + 4194303 ($2^{22}-1$)</p>
0x00000002	Minimum Value	<p>SPECIAL PIN FUNCTION: "Data-Bit / Data-Bit": Measured value is less than + 16777216 (2^{24})</p> <p>Special PIN FUNCTION "Error" or "Data – Stable": Measured value is less than - 8388608 (2^{23})</p> <p>SPECIAL PIN FUNCTION "Error" and "Data – Stable": (or negated accordingly) Measured value is less than - 4194304 (2^{22})</p>
0x00000004	SSI Encoder Error	SSI Error bit set (SSI mode only)
0x00000010	Frequency (Input A) out of range	The maximum or minimum permissible input frequency at input A was exceeded or not reached with the exponential filter setting used. (Frequency mode only)
0x00000020	Frequency (Input B) out of range	The maximum or minimum permissible input frequency at input B was exceeded or not reached with the exponential filter setting used. (Frequency mode only)
0x00000040	Start/Stop Encoder Error	No "start" and no "stop" pulse detected between two "init" pulses. (only for mode: Start/Stop)

Error code (Error_Status)	Error name	Error description
		Check sensor connections!
0x00000080	Position Encoder Outside the Limit	No "stop" pulse detected between two "init" pulses. (only for mode: Start/Stop) Possible cause: No position sensor or position sensor outside the limits.

3. Electrical Connections

The terminals should be tightened with a slotted screwdriver (blade width 2 mm).

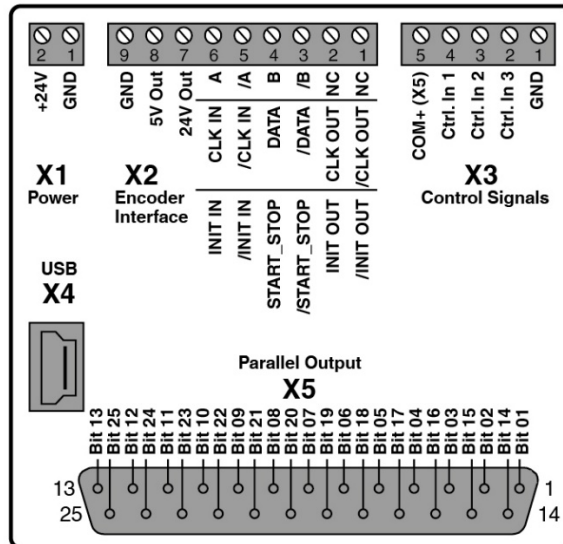

3.1 DC Voltage Supply (X1)

The device can be supplied with a DC voltage between 10 and 30 V DC via terminal X1 pins 1 and 2. The current consumption depends, among other things, on the level of the supply voltage and the settings and is approx. 25 mA, plus the rotary encoder current taken from the auxiliary voltage output.

All GND connections are connected internally.

3.2 Auxiliary Voltage Output (X2)

Two auxiliary voltages 24 V DC and 5 V DC are available as encoder/sensor supply at terminal X2 pins 7, 8, and 9. The 24 V DC output voltage depends on the device supply (see data sheet).

3.3 Incremental Rotary Encoder Input (X2)

A connection for various incremental signals is available at terminal X2 pins 3, 4, 5, and 6.

RS422

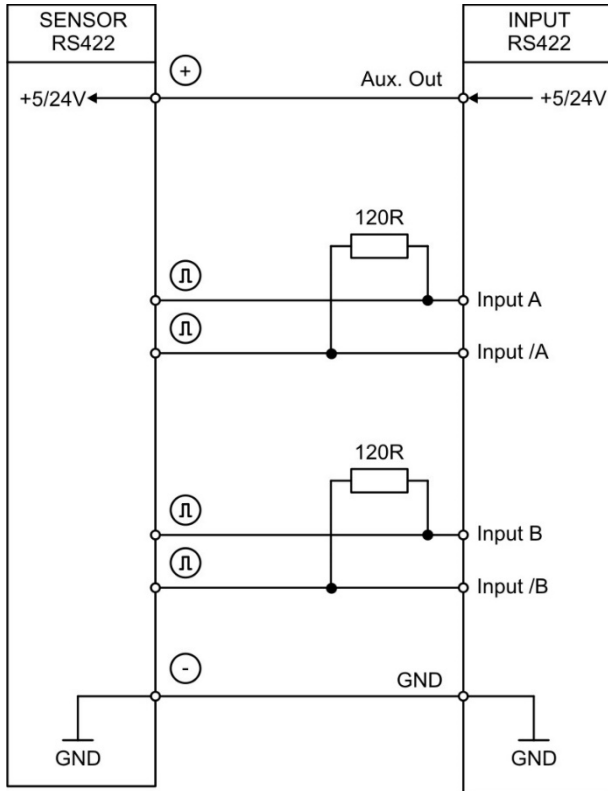

HTL DIFFERENTIAL

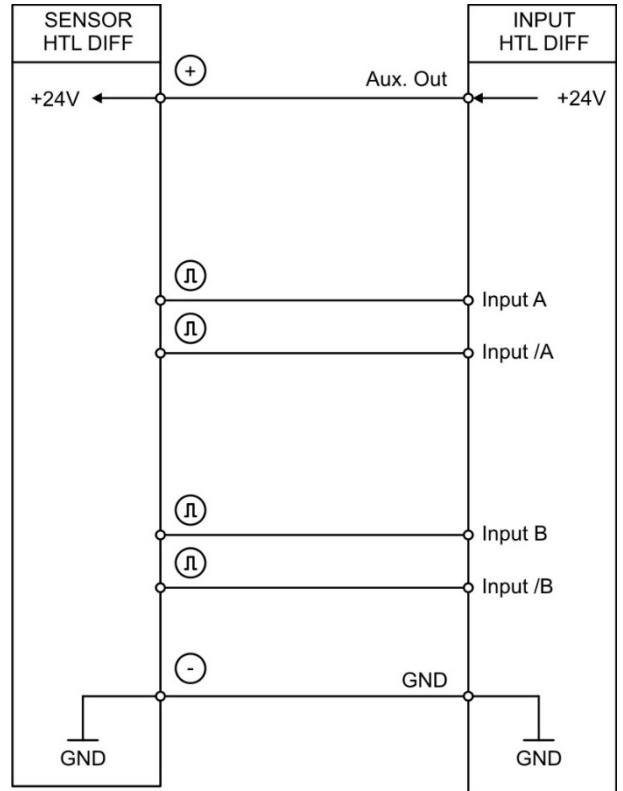

HTL PNP

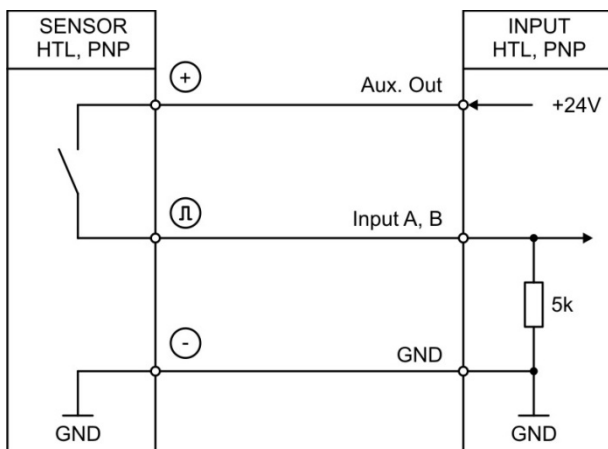

HTL NPN

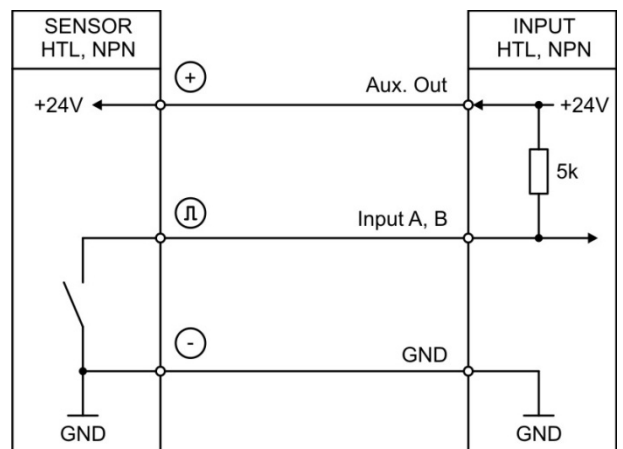

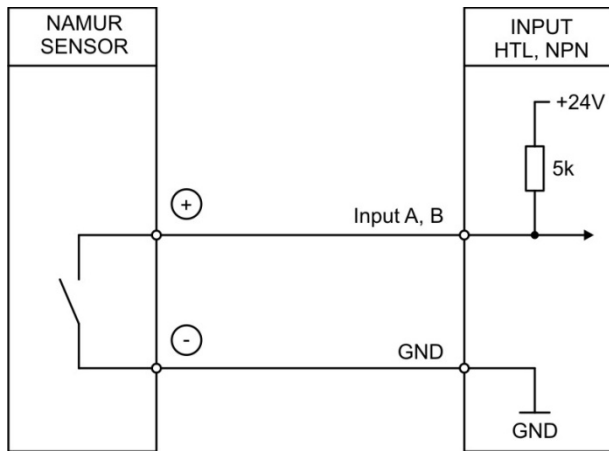
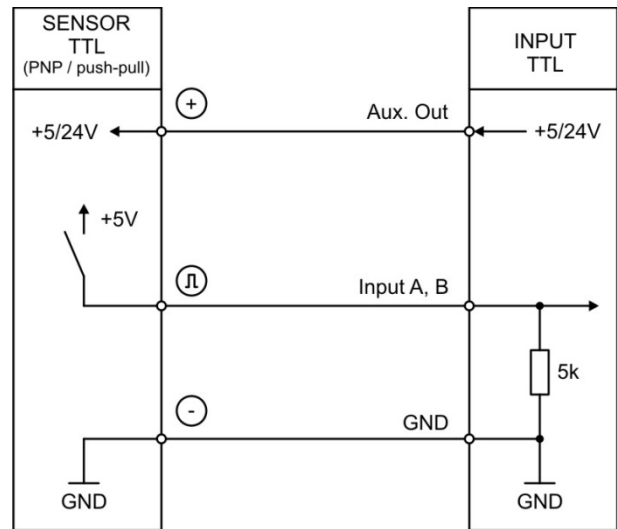
HTL NPN (NAMUR)**TTL (PNP)**

In general, open PNP inputs are "LOW" and open NPN inputs are "HIGH."

The input stages are designed for electronic pulse generators.

Note for mechanical switching contacts:

If, in exceptional cases, mechanical contacts are to be used as a pulse source, a commercially available external capacitor of approx. 10 μF must be installed at the terminals between GND (-) and the corresponding input (+). This attenuates the maximum input frequency to approximately 20 Hz and suppresses bouncing.

3.4 Absolute Rotary Encoder Input (X2)

The SSI connection is available for managing operation at terminal X2 pins 1, 2, 3, 4.

The SSI connection is available for managed operation at terminal X2 pins 3, 4, 5, 6.

Connection for managing operation:

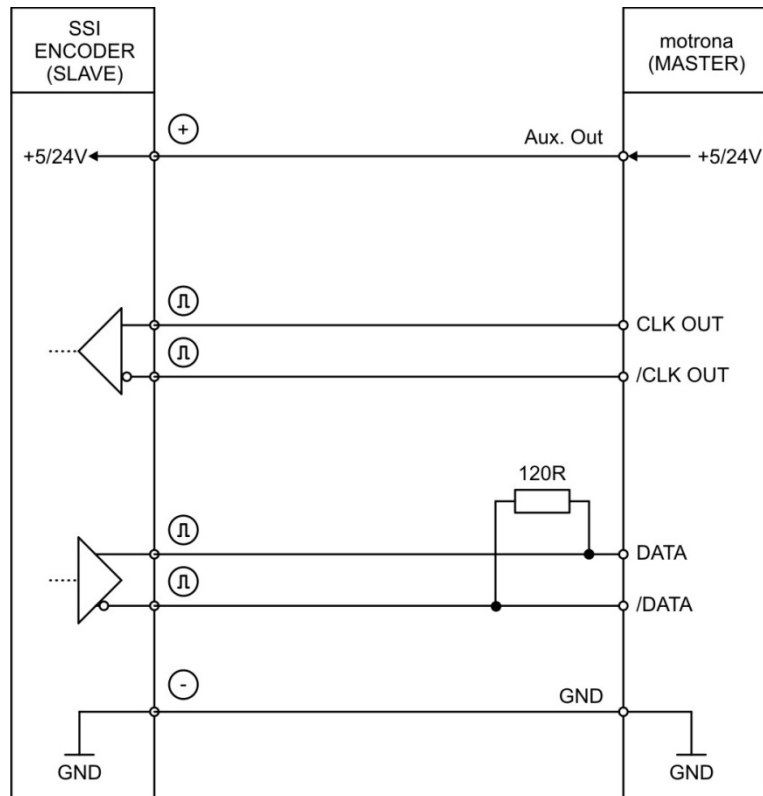

Connection for managed operation:

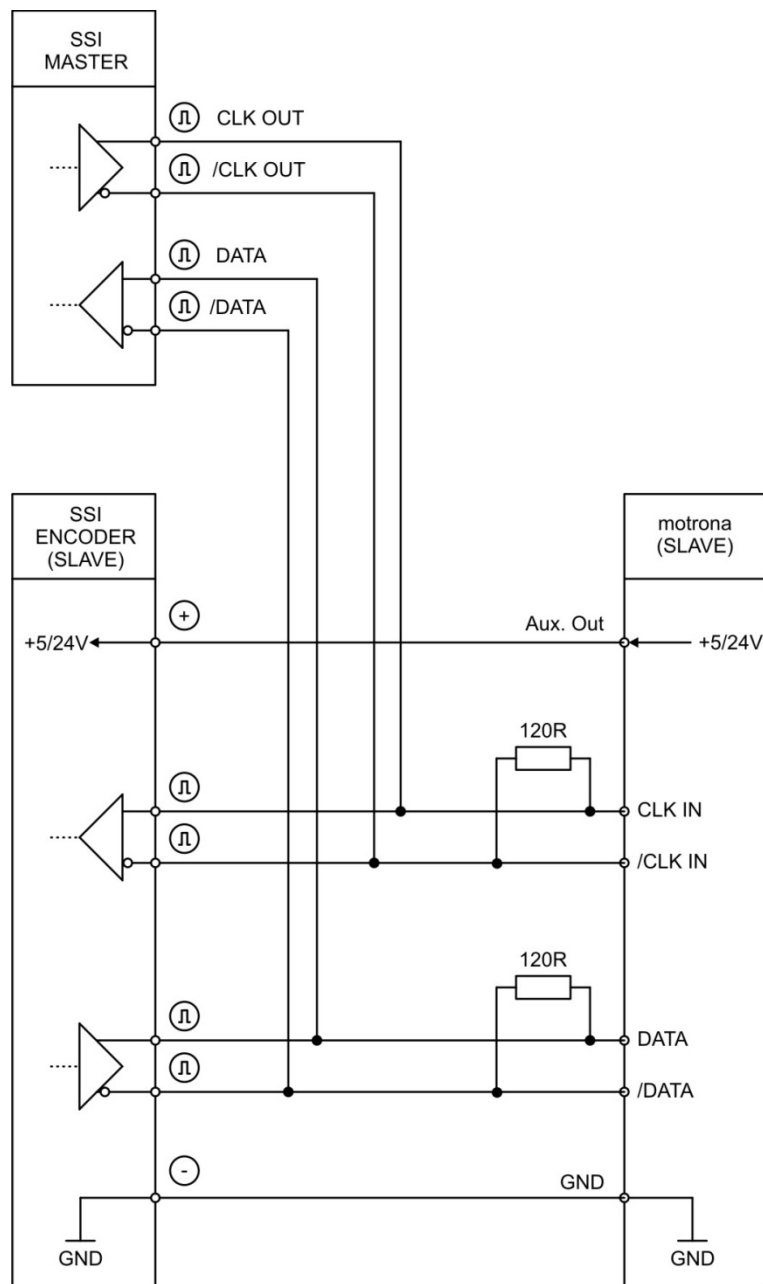

3.5 Start/Stop Encoder Inputs (X2)

The RS422 connection is available for the init pulse in managing operation at terminal X2 pins 1 + 2. The device generates the init pulse.

The RS422 connection is available for the init pulse in managed operation at terminal X2 pins 5 + 6. The init pulse is generated by an external device.

The RS422 connection is available for the Start/Stop pulse at terminal X2 pins 3 + 4.

Connection of the RS422 signals

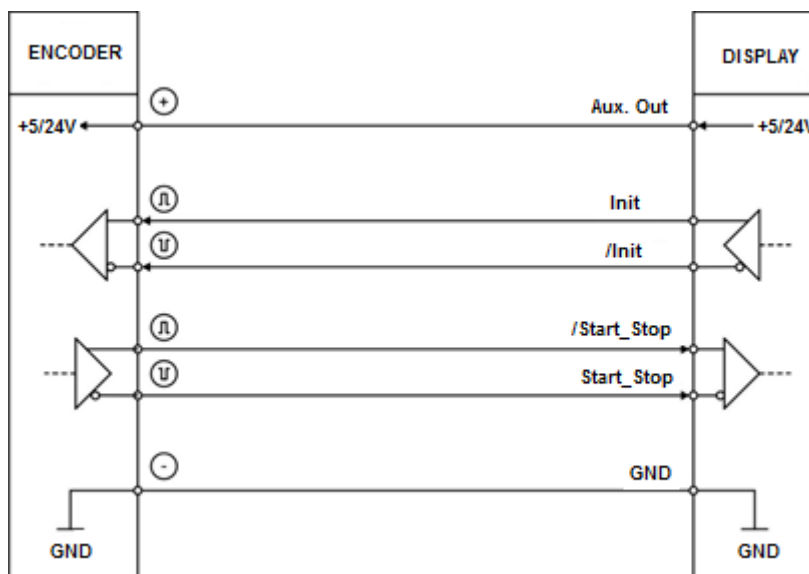

DPI measurement mode:

In managing operation, the init pulse is sent at regular intervals (=SAMPLING TIME [ms]) on the init line to the displacement transducer, the rising edge of which triggers a measurement.

The pulse duration of the init pulse can be set using the "INIT pulse TIME (μs)" parameter.

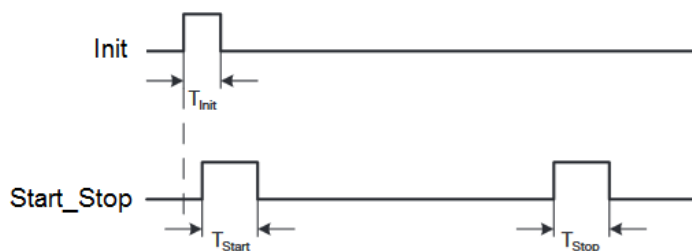

T_{init} : 1 μs ... 9 μs (adjustable)

T_{Start} : ~3 μs ... 5 μs

T_{Stop} : ~3 μs ... 5 μs

3.6 Control Inputs (X3)

Six control inputs with HTL-PNP characteristics are available at terminal X5 pins 2, 3 and 4.

Control input 1 (Ctrl. In 1) to control input 2 (Ctrl. In 2) are freely configurable in the COMMAND menu and are used for externally triggered functions such as resetting the measurement result or for freezing the parallel output.

Control input 3 (Ctrl. In 3) is used exclusively for resetting the device parameters to the "default" values and is therefore not freely configurable.



Note

An HTL pulse (rising edge) at Ctrl. In 3 resets the device to factory settings. The HTL pulse must be present for at least one second.

Connection of the control inputs:

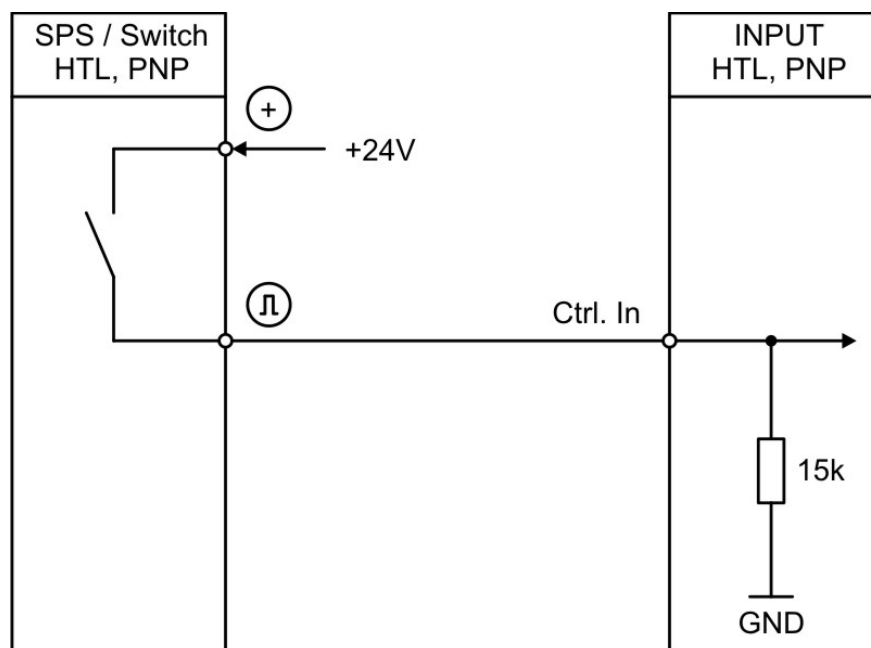

Generally, open control inputs are "LOW."

The input stages are designed for electronic control signals.

Note for mechanical switching contacts:

With mechanical contacts as a pulse source, a commercially available external capacitor of approx. 10 μF must be installed between GND (-) and the corresponding input (+). This attenuates the maximum input frequency to approximately 20 Hz and suppresses bouncing.

3.7 Parallel output (X5) / COM + (X3)

The parallel outputs are 25 short-circuit proof push-pull outputs. The common, independent supply voltage of the outputs is applied to terminal X3 - pin 5 (COM +). The supply voltage at COM + should not exceed +27 V, otherwise the permanent short circuit resistance of the outputs can no longer be guaranteed.

The voltage drop between COM + and an output in the HIGH state is approx. 1 volt (unloaded).

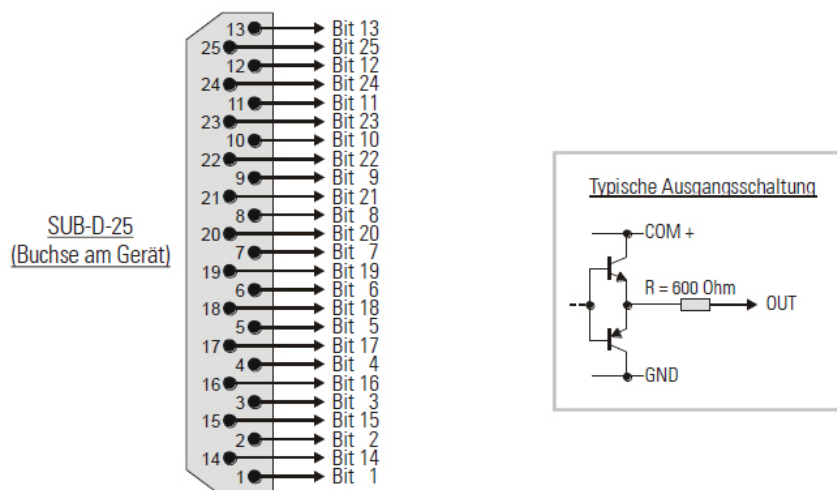

3.7.1 Output „Error“

In the parallel menu using the “SPECIAL PIN FUNCTION” parameter the output bit 25 (or Bit 24 - if a datastable signal is also configured) can also be set as “Error” signal. In this case, a LOW signal (or HIGH signal) indicates that an error has been detected.

3.7.2 Output “Data stable”

The output Bit 25 can also be configured as a “Data stable” signal by using “SPECIAL PIN FUNCTION” parameter (in parallel menu). In this case a LOW signal (or HIGH signal) indicates that parallel output data are stable and will not change. The rising edge (or falling edge) of the signal still guarantees stable data and can be used for remote Latch of the parallel data.

The LOW duration (or HIGH duration) of the signal is at least 1/3 of the "Parallel Update Time (s)" set. The sketch below shows the signal path of the "Data stable" output with the "Active Low" setting. With the "Active High" setting, the signal curve is inverted accordingly.

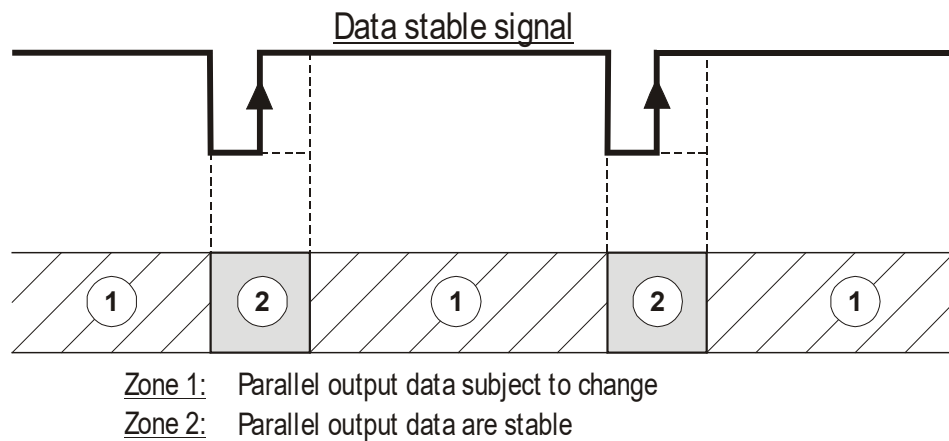

3.8 Serial Interface (X4)

A serial USB interface (mini USB) is available at terminal X4.

The USB interface can be used as follows:

- For parameterization of the device during commissioning
- For changing parameters during operation
- For reading out actual values via PC



Note

The serial USB communication is carried out at a baud rate of 115200 baud and a serial data format of 8none1.

These values cannot be changed by the user!

4. Operating Software OS6.0

The device is parameterized via the serial interface using a PC and the OS6.0 operating software.

The free operating software OS6.0 can be found at Pepperl-Fuchs.com

This section shows the overview of the individual menus and their parameters.

Menu	Parameter
GENERAL MENU	MODE ENCODER PROPERTIES ENCODER DIRECTION FACTOR DIVIDER ADDITIVE VALUE LINEARIZATION MODE BACKUP MEMORY FACTORY SETTINGS
FREQUENCY MODE	FREQUENCY MODE FREQUENCY BASE SAMPLING TIME 1 (S) WAIT TIME 1 (S) STANDSTILL TIME 1 (S) AVERAGE FILTER 1 SAMPLING TIME 2 (S) WAIT TIME 2 (S) AVERAGE FILTER 2
COUNTER MODE	COUNT MODE FACTOR A SET VALUE A FACTOR B SET VALUE B ROUND LOOP VALUE
SSI MODE	SSI MODE ENCODER RESOLUTION DATA FORMAT BAUD RATE SSI ZERO HIGH BIT

Menu	Parameter
	LOW BIT SSI OFFSET ROUND LOOP VALUE SAMPLING TIME (S) ERROR BIT ERROR POLARITY
START/STOP MODE	INIT MODE SAMPLING TIME (ms) INIT PULSE TIME (μs) VELOCITY (m/s) OPERATIONAL MODE OFFSET CIRCUMFERENCE (mm) ROUND LOOP VALUE AVERAGE FILTER - POSITION STANDSTILL TIME (s) AVERAGE FILTER - SPEED
SERIAL MENU	UNIT NUMBER SERIAL BAUD RATE SERIAL FORMAT SERIAL INIT SERIAL PROTOCOL SERIAL TIMER (S) SERIAL VALUE MODBUS
PARALLEL MENU	PARALLEL MODE PARALLEL INV. PARALLEL VALUE PARALLEL UPDATE TIME (s) SPECIAL PIN FUNCTION
COMMAND MENU	INPUT 1 ACTION INPUT 1 CONFIG INPUT 2 ACTION INPUT 2 CONFIG INPUT 3 ACTION (FACTORY SETTINGS) INPUT 3 CONFIG (RISING EDGE)
LINEARIZATION MENU	P1(X)

Menu	Parameter
	P1(Y)
	P2(X)
	P2(Y)
	...
	P23(X)
	P23(Y)
	P24(X)
	P24(Y)

4.1 General Menu

MODE (operating mode)

This parameter defines which measurement function (operating mode/mode) the device should fulfill.

Value	Designation	Function
0	NOT DEFINED	Operating mode: Not defined, modulation and measurement results are zero
1	FREQUENCY	Operating mode: Frequency converter, incremental signals
2	COUNTER	Operating mode: Counter, incremental signals
3	SSI	Operating mode: Absolute value converter, SSI signals
4	START/STOP	Operating mode: Start/Stop interface converter

ENCODER PROPERTIES

This parameter defines the characteristics of the incremental input.

(Note: Only relevant for MODE: "FREQUENCY" and MODE: "COUNTER")

Value	Designation	Function
0	RS422	RS422 standard
1	HTL DIFFERENTIAL	HTL differential
2	HTL PNP	PNP (switching to +)
3	HTL NPN	NPN (switching to -)
4	TTL PNP	TTL PNP (switching to +)

ENCODER DIRECTION

This parameter reverses the direction of counting and/or travel.

Value	Designation	Function
0	FORWARD	Forward
1	REVERSE	Backward

FACTOR (multiplication factor)

This parameter defines the factor by which the measurement result is multiplied.

Value	Function
-99999999	Smallest value
1	Default value
99999999	Largest value

DIVIDER (division factor)

This parameter defines the divisor by which the measurement result is divided.

Value	Function
-99999999	Smallest value
1	Default value
99999999	Largest value

ADDITIVE VALUE (additive constant)

This parameter defines an additive constant, which is added to the measurement result.

Value	Function
-99999999	Smallest value
0	Default value
99999999	Largest value

LINEARIZATION MODE

This parameter defines the linearization function. Note the information in the appendix!

Value	Designation	Function
0	OFF	No linearization
1	1 QUADRANT	Linearization in the first quadrant

Value	Designation	Function
2	4 QUADRANT	Linearization in all four quadrants

BACKUP MEMORY (retentive memory)

Note: Only relevant for MODE: "COUNTER"

Value	Designation	Function
0	NO	No retentive memory
1	YES	Retentive memory active. Stores the actual value of the counter readings in the event of a power failure and "counter" mode is switched on.

FACTORY SETTINGS

Value	Designation	Function
0	NO	The factory settings are not loaded
1	YES	The factory settings are loaded

4.2 Frequency Mode

In this menu, the operation is defined as a frequency converter (incremental signals). Depending on the operating mode set, only channel A or both channels (channel A and channel B) are active.

FREQUENCY MODE

This parameter determines which operating mode of the frequency measurement is desired.

Value	Designation	Function
0	A ONLY	Single-channel frequency measurement (only for channel A).
1	RATIO	Frequency ratio of both channels (channel B / channel A). <u>Note:</u> Interpretation of the result with four decimal places in the format +/- x.xxxx
2	PERCENT	Percentage deviation from channel B to channel A. <u>Note:</u> Interpretation of the result with two decimal places in the format +/- xxx.xx %
3	A + B	Frequency addition of both channels (channel A + channel B)
4	A - B	Frequency subtraction of both channels (channel A - channel B)

Value	Designation	Function
5	A/B x 90°	Frequency measurement with A/B x 90° signal. (Forward/backward—rotation direction monitoring)

FREQUENCY BASE

Sets the desired base for frequency measurement (resolution).

Value	Function
0	1 Hz (Interpretation of result in format: xxxxxxxx Hz)
1	1/10 Hz (Interpretation of result in format: xxxxxxx.x Hz)
2	1/100 Hz (Interpretation of result in format: xxxxxx.xx Hz)
3	1/1000 Hz (Interpretation of result in format: xxxxx.xxx Hz)

SAMPLING TIME 1 (S)

The set value is the minimum measuring time (for channel A) in seconds. The sampling time acts as a filter for irregular frequencies. This parameter directly affects the reaction time of the device.

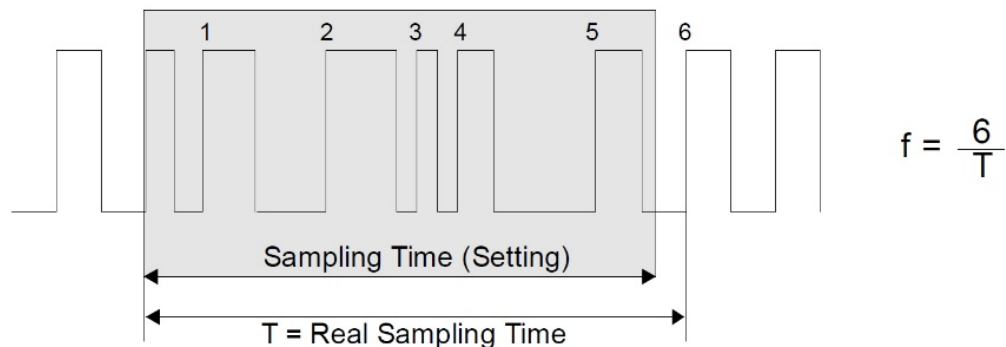

Value	Function
0.001	Minimum measuring time in seconds
0.1	Default value
9.999	Maximum measuring time in seconds

WAIT TIME 1 (S)

The set value is the zero setting time. This parameter defines the duration of the lowest frequency, or the waiting time between two rising edges on channel A, at which the device detects the 0 Hz frequency. Frequencies with a duration greater than the set WAIT TIME 1 are evaluated as frequency = 0 Hz.

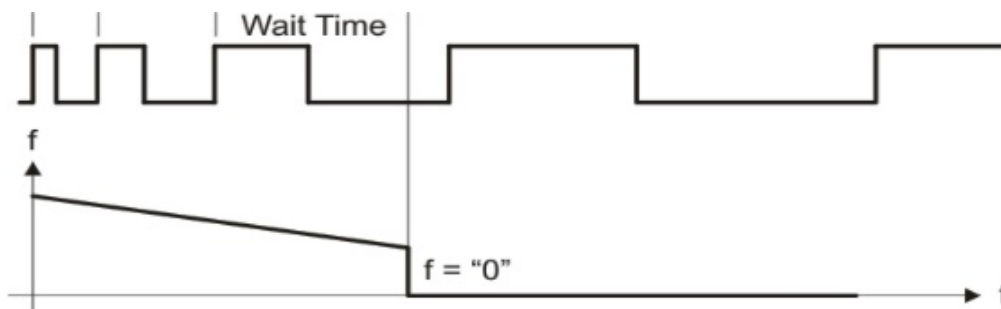

Value	Function
0.01	Frequency = 0 Hz for frequencies less than 100 Hz
1.00	Default value
79.99	Frequency = 0 Hz for frequencies less than ~ 0.01 Hz

STANDSTILL TIME 1 (S)

This parameter defines the downtime. If frequency = 0 Hz is detected at channel A, a downtime is signaled after xx.xx seconds and the startup override is reactivated. Downtime monitoring can be set in the PRESELECTION menu.

Value	Function
0.01	Shortest delay time in seconds
...	
99.99	Longest delay time in seconds

AVERAGE FILTER 1 (average determination)

Switchable average determination or filter function at unstable frequencies at input A for smoothing the analog signal. If the filter is set to 5 ... 16, the device uses an exponential function. The time constant T (63 %) corresponds to the number of sampling cycles.

For example, SAMPLING TIME = 0.1 s and AVERAGE FILTER = exponential filter,

$T (63\%) = 2 \times \text{sampling time}$.

This means that after 0.2 s, 63 % of the jump height is reached.

Value	Function
0	No average determination (quick response to any change)
1	Flowing average determination with two cycles
2	Flowing average determination with four cycles
3	Flowing average determination with eight cycles
4	Flowing average determination with 16 cycles
5	Exponential filter, T (63 %) = 2x SAMPLING TIME
6	Exponential filter, T (63 %) = 4x SAMPLING TIME
7	Exponential filter, T (63 %) = 8x SAMPLING TIME
8	Exponential filter, T (63 %) = 16x SAMPLING TIME
9	Exponential filter, T (63 %) = 32x SAMPLING TIME
10	Exponential filter, T (63 %) = 64x SAMPLING TIME
11	Exponential filter, T (63 %) = 128x SAMPLING TIME
12	Exponential filter, T (63 %) = 256x SAMPLING TIME
13	Exponential filter, T (63 %) = 512x SAMPLING TIME
14	Exponential filter, T (63 %) = 1024x SAMPLING TIME
15	Exponential filter, T (63 %) = 2048x SAMPLING TIME
16	Exponential filter, T (63 %) = 4096x SAMPLING TIME (very slow reaction)



CAUTION!

Maximum permissible frequency

When using the exponential filter, the maximum permissible frequencies at the input must not be exceeded otherwise a data type overflow will follow!

If the frequency is still exceeded, the frequency is replaced by the maximum permissible value with the corresponding setting for further calculation and an error is output. The LED flashes. The maximum permissible frequencies are listed below for the corresponding settings.

		FREQUENCY BASE			
		[0] – 1 Hz	[1] – 1/10 Hz	[2] – 1/100 Hz	[3] – 1/1000 Hz
AVERAGE FILTER 1+2	[5] - 2x	1,073,741,823 Hz	107,374,182.3 Hz	10,737,418.23 Hz	1,073,741.823 Hz
	[6] - 4x	536,870,911 Hz	53,687,091.1 Hz	5,368,709.11 Hz	536,870.911 Hz
	[7] - 8x	268,435,455 Hz	26,843,545.5 Hz	2,684,354.55 Hz	268,435.455 Hz
	[8] - 16x	134,217,727 Hz	13,421,772.7 Hz	1,342,177.27 Hz	134,217.727 Hz
	[9] - 32x	67,108,863 Hz	6,710,886.3 Hz	671,088.63 Hz	67,108.863 Hz

[10] - 64x	33,554,431 Hz	3,355,443.1 Hz	335,544.31 Hz	33,554.431 Hz
[11] - 128x	16,777,215 Hz	1,677,721.5 Hz	167,772.15 Hz	16,777.215 Hz
[12] - 256x	8,388,607 Hz	838,860.7 Hz	83,886.07 Hz	8388.607 Hz
[13] - 512x	4,194,303 Hz	419,430.3 Hz	41,943.03 Hz	4194.303 Hz
[14] - 1024x	2,097,151 Hz	209,715.1 Hz	20,971.51 Hz	2097.151 Hz
[15] - 2048x	1,048,575 Hz	104,857.5 Hz	10,485.75 Hz	1048.575 Hz
[16] - 4096x	524,287 Hz	52,428.7 Hz	5242.87 Hz	524.287 Hz

SAMPLING TIME 2 (S)

The set value is the minimum measuring time (for channel B) in seconds. The sampling time acts as a filter for irregular frequencies. This parameter directly affects the reaction time of the device.

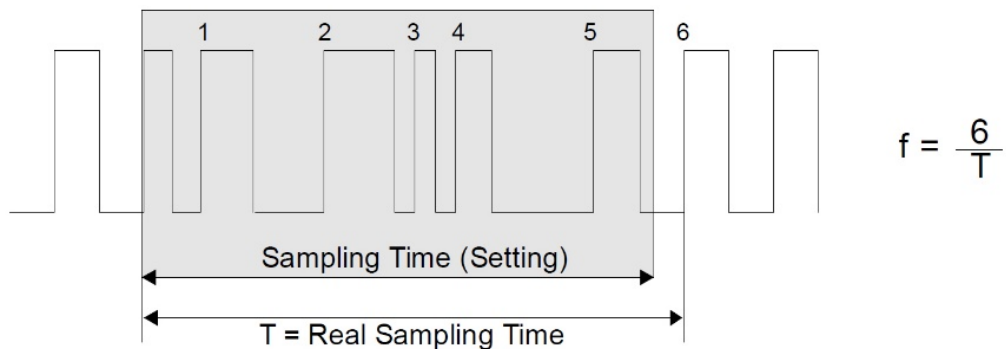

Value	Function
0.001	Minimum measuring time in seconds
0.1	Default value
9.999	Maximum measuring time in seconds

WAIT TIME 2 (S)

The set value is the zero setting time. This parameter defines the duration of the lowest frequency, or the waiting time between two rising edges on channel B, at which the device detects the 0 Hz frequency. Frequencies with a duration greater than the set WAIT TIME 2 are evaluated as frequency = 0 Hz.

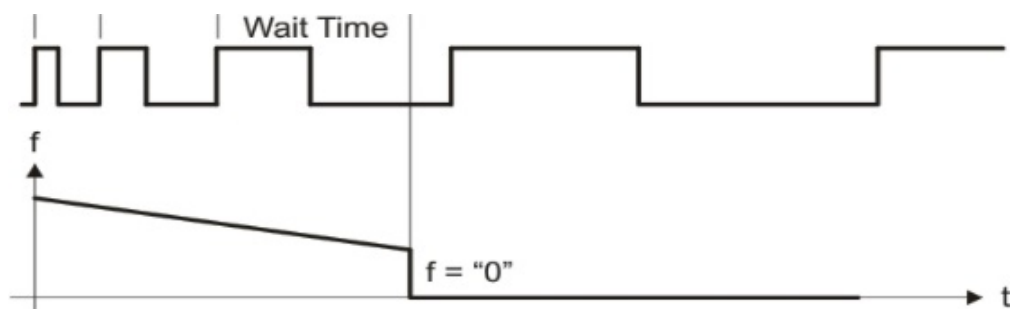

Value	Function
0.01	Frequency = 0 Hz for frequencies less than 100 Hz
1.00	Default value
79.99	Frequency = 0 Hz for frequencies less than ~ 0.01 Hz

AVERAGE FILTER 2 (average determination)

Switchable average determination or filter function at unstable frequencies at input B for smoothing the analog signal. If the filter is set to 5 ... 16, the device uses an exponential function. The time constant T (63 %) corresponds to the number of sampling cycles.

E.g., SAMPLING TIME = 0.1 s and AVERAGE FILTER = exponential filter,
T (63 %) = 2 x sampling time.

This means that after 0.2 s, 63 % of the jump height is reached.

Value	Function
0	No average determination (quick response to any change)
1	Flowing average determination with two cycles
2	Flowing average determination with four cycles
3	Flowing average determination with eight cycles
4	Flowing average determination with 16 cycles
5	Exponential filter, T (63 %) = 2x SAMPLING TIME
6	Exponential filter, T (63 %) = 4x SAMPLING TIME
7	Exponential filter, T (63 %) = 8x SAMPLING TIME
8	Exponential filter, T (63 %) = 16x SAMPLING TIME
9	Exponential filter, T (63 %) = 32x SAMPLING TIME
10	Exponential filter, T (63 %) = 64x SAMPLING TIME
11	Exponential filter, T (63 %) = 128x SAMPLING TIME
12	Exponential filter, T (63 %) = 256x SAMPLING TIME
13	Exponential filter, T (63 %) = 512x SAMPLING TIME
14	Exponential filter, T (63 %) = 1024x SAMPLING TIME
15	Exponential filter, T (63 %) = 2048x SAMPLING TIME
16	Exponential filter, T (63 %) = 4096x SAMPLING TIME (very slow reaction)



CAUTION!

Maximum permissible frequency

When using the exponential filter, the maximum permissible frequencies at the input must not be exceeded otherwise a data type overflow will follow!

If the frequency is still exceeded, the frequency is replaced by the maximum permissible value with the corresponding setting for further calculation and an error is output. The LED flashes. The maximum permissible frequencies have already been listed in the AVERAGE FILTER 1 parameter and can be taken from there.

4.3 Counter Mode

In this menu, the operation is defined as a position converter for incremental signals (pulse, sum, difference, incrementing, or decrementing counter.) Input A and B are active.

COUNT MODE

Selecting the counter configuration

Value	Designation	Function
0	A SINGLE	Input A is the counter input. Input B determines the counting direction: "LOW" = forward / "HIGH" = backward
1	A + B	Total: Counts A pulses + B pulses
2	A - B	Difference: Counts A pulses - B pulses
3	A/B 90 x1	Incrementing/decrementing counter for pulses with 2x90° offset (Single edge evaluation x1)
4	A/B 90 x2	Incrementing/decrementing counter for pulses with 2x90° offset (Double edge evaluation x2)
5	A/B 90 x4	Incrementing/decrementing counter for pulses with 2x90° offset (Quadruple edge evaluation x4)

FACTOR A

Pulse scaling factor for input A.

Example: if set to 1.23456, the device displays the value 123456 after 100,000 input pulses.

Value	Function
0.00001	Smallest value
1	Default value
99.99999	Largest value

SET VALUE A

In the case of a "RESET/SET COUNTER A" command (via control input), the counter of input A is set to the value set here.

Value	Function
-99999999	Smallest value
0	Default value
99999999	Largest value

FACTOR B

Pulse scaling factor for input B.

Example: if set to 1.23456, the device displays the value 123456 after 100,000 input pulses.

Value	Function
0.00001	Smallest value
1	Default value
99.99999	Largest value

SET VALUE B

In the case of a "RESET/SET COUNTER B" command (via control input), the counter of input B is set to the value set here.

Value	Function
-99999999	Smallest value
0	Default value
99999999	Largest value

ROUND LOOP VALUE

Defines the number of encoder steps if a concentricity function is desired. (Only for COUNT MODE: A SINGLE and A/B x 90)

Value	Function
0	No concentricity
...	
99999999	Number of steps for the concentricity function

4.4 SSI Mode

In this menu, the operation is defined as an absolute value converter (SSI signals).

SSI MODE

SSI setting of the operating mode: Managing or managed

Depending on the SSI MODE, different terminals must be used for the SSI CLK:

Managing operation: Terminal X2—pins 1 and 2

Managed operation: Terminal X2—pins 5 and 6)

Value	Designation	Function
0	PRIMARY	Managing operation: Clock pulse for SSI rotary encoder is generated by the device.
1	SECONDARY	Managed operation: Clock pulse for SSI rotary encoder comes from external control.

ENCODER RESOLUTION

Resolution of the SSI rotary encoder (total number of all bits)

Value	Function
10	Smallest value
25	Default value
32	Largest value

DATA FORMAT

Setting of the SSI code (binary or gray)

Value	Designation	Function
0	GRAY CODE	Gray SSI code
1	BINARY CODE	Binary SSI code

BAUD RATE

Clock frequency of the SSI messages

Value	Designation	Function
0	2 MHZ	N.A.
1	1.5 MHZ	N.A.
2	1 MHZ	Clock frequency 1 MHz
3	500 KHZ	Clock frequency 500 kHz
4	250 KHZ	Clock frequency 250 kHz
5	100 KHZ	Clock frequency 100 kHz

SSI ZERO

In the event of a "ZERO POSITION" command (via control input), the current SSI position of the rotary encoder is transferred to the "SSI ZERO" parameter and the actual rotary encoder zero point is shifted accordingly. (rotary encoder zero point shift)

Value	Function
0	Smallest value
...	
999999999	Largest value

HIGH BIT (for bit suppression)

Defines the highest bit (MSB) to be evaluated of the bit suppression.

If all bits are to be evaluated, HIGH BIT must be set to the specified total bit number.

Value	Function
01	Smallest value
25	Default value
32	Largest value

LOW BIT (for bit suppression)

Defines the lowest bit (LSB) to be evaluated of the bit suppression.

If all bits are to be evaluated, LOW BIT must be set to "01."

Value	Function
01	Smallest value
...	
32	Largest value

SSI OFFSET

In the case of a "RESET/SET VALUE" command (via control input or PC user interface), the as yet unscaled position value currently being recorded (after bit suppression and any rotary encoder zero point shift) is transferred to the "SSI OFFSET" parameter and the measurement result is reset to zero. From the new zero point, it is now possible to move in the positive and negative directions, depending on the direction of rotation.

(Display zero point shift)

Value	Function
0	Smallest value
...	
999999999	Largest value

ROUND LOOP VALUE

Defines the number of rotary encoder steps if a concentricity function is desired.

Value	Function
0	No concentricity
...	
999999999	Number of steps for the concentricity function

SAMPLING TIME (S)

Determines the read-in cycle for the SSI signal in the measuring operation

Value	Function
0.001	Minimum measuring time in seconds
0.010	Default value
9.999	Maximum measuring time in seconds

ERROR BIT

Defines the rotary encoder monitoring and the error bit

Value	Function
0	No error bit present. Checks that the connected rotary encoder is switched off.
...	
32	Position of the error bit to be evaluated. Checks that the connected rotary encoder is switched on.

ERROR POLARITY

Defines the polarity of the error bit in the event of a fault

Value	Function
0	Bit is low in the event of a fault
1	Bit is high in the event of a fault



Note

SSI values

To process SSI values, see Appendix

4.5 Start/Stop Mode

In this menu, the operation is defined as a start/stop interface converter.

INIT MODE

Managing or managed operation

Depending on the selected INIT MODE, different terminals must be used for the init pulse.

Managing operation: Terminal X2—pins 1 and 2

Managed operation: Terminal X2—pins 5 and 6

Value	Designation	Function
0	PRIMARY	Managing operation: Init pulse is generated by the device
1	SECONDARY	Managed operation: Init pulse is generated externally

SAMPLING TIME (ms)

Duration between two init pulses in milliseconds. Corresponds to the time after which a new measurement is started and directly affects the reaction time of the device.

Value	Function
00.200	Minimum measuring time
04.000	Default value
16.000	Maximum measuring time

INIT PULSE TIME (μs)

This parameter defines the pulse duration of the init pulse in microseconds.

Value	Function
1	Smallest value
2	Default value
9	Largest value

VELOCITY (m/s)

Waveguide velocity of the encoder used in m/s.

Value	Function
0001.00	Smallest value
2800.00	Default value
9999.99	Largest value

OPERATIONAL MODE

This parameter determines which type of measurement the device is to perform.

Value	Designation	Function
0	POSITION	Distance measurement
1	ANGLE	Angle measurement
2	SPEED	Velocity measurement



Note

For more information on the different "OPERATIONAL MODES" and interpretation of the respective measurement results, see Chapter 6.7)

OFFSET

In the event of a "Reset/Set Value" command via the control input or the PC user interface, the current position of the rotary encoder is transferred

in a non-volatile manner to the "OFFSET" parameter. (= zero point shift)

Value	Function
-99999999	Smallest value
0	Default value
99999999	Largest value

CIRCUMFERENCE (mm)

Sets the reference quantity in mm for an angle measurement.

The distance traveled, e.g., the extent to which to generate the subsequent ROUND LOOP VALUE, must be set here.

Value	Function
00000.001	Smallest value
01000.000	Default value
99999.999	Largest value



Note

Only for OPERATIONAL MODE: "ANGLE"

ROUND LOOP VALUE

Sets the desired data to be generated when the previous reference quantity CIRCUMFERENCE is reached.



Note

Only for OPERATIONAL MODE: "ANGLE"

Value	Function
1	Smallest value
360	Default value
99999999	Largest value

AVERAGE FILTER—POSITION (filter for average determination)

Switchable average determination for preventing position fluctuations.

Value	Function
0	No average determination
1	Flowing average determination with two cycles
2	Flowing average determination with four cycles
3	Flowing average determination with eight cycles
4	Flowing average determination with 16 cycles

STANDSTILL TIME(s)

This parameter defines the downtime. When downtime is detected, a downtime signal is signaled after xx.xx seconds.

Value	Function
0.01	Shortest delay time in seconds
...	
99.99	Longest delay time in seconds

AVERAGE FILTER—SPEED (filter for average determination)

Switchable average determination for preventing velocity fluctuations.

Value	Function
0	No average determination
1	Flowing average determination with two cycles
2	Flowing average determination with four cycles
3	Flowing average determination with eight cycles
4	Flowing average determination with 16 cycles

4.6 Serial Menu

The default settings for the serial interface are defined in this menu.

UNIT NUMBER

This parameter can be used to set serial device addresses. The devices can be assigned addresses between 11 and 99. Addresses that contain a "0" are not allowed since these are used as group or collective addresses.

Value	Function
11	Smallest address without zero
...	-
99	-



Note

Device address is fixed to "11" for USB interface and cannot be adjusted

SERIAL BAUD RATE

This parameter is used to set the serial baud rate.

Value	Designation	Function
0	9600	-
1	19,200	-
2	38,400	-
3	115200	115200 baud



Note

The baud rate is fixed to 115200 for USB interface and cannot be adjusted.

SERIAL FORMAT

This parameter sets the bit data format.

Value	Designation	Function
0	7-EVEN-1	7 data Parity even 1 stop
1	7-EVEN-2	7 data Parity even 2 stops
2	7-ODD-1	7 data Parity odd 1 stop
3	7-ODD-2	7 data Parity odd 2 stops
4	7-NONE-1	7 data No parity 1 stop
5	7-NONE-2	7 data No parity 2 stops
6	8-EVEN-1	8 data Parity even 1 stop
7	8-ODD-1	8 data Parity odd 1 stop
8	8-NONE-1	8 data No parity 1 stop
9	8-NONE-2	8 data No parity 2 stops



Note

The Serial data format is fixed to 8-none-1 for USB interface and cannot be adjusted.

SERIAL INIT

This parameter determines the baud rate at which the initialization values are transferred to the PC user interface. When set to greater than 9600 baud, the duration of the initialization can be shortened.

Value	Designation	Function
0	NO	The initialization values are transferred at 9600 baud. The device then works again at the value set by the user
1	YES	The initialization values are transmitted at the baud rate set by the user in the SERIAL BAUD RATE parameter. The device then continues to work at the value set by the user

SERIAL PROTOCOL

Specifies the string for command-controlled or timed transmissions

(xxxxxxx = SERIAL VALUE).

At default 1, the unit no. is omitted and the transmission starts directly with the measured value, which enables a quicker transmission cycle.

Value	Function											
0	Transmission protocol = unit no., +/-, data, LF, CR											
	1	1	+/-	X	X	X	X	X	X	X	LF	CR
1	Transmission protocol = +/-, data, LF, CR											
			+/-	X	X	X	X	X	X	X	LF	CR

SERIAL TIMER (S)

Adjustable time cycle in seconds for automatic (cyclical) transmission of the SERIAL VALUE via the serial interface.

In the event of a request via the request protocol, the cyclical transmission is interrupted for 20 seconds.

Value	Function
0.000	Cyclical transmission is switched off and the device only sends SERIAL PRINT on command via a control input or request via request protocol
...	
60.000	Time cycle in seconds.

SERIAL VALUE

The parameter determines which value is transmitted.

Value	Code	Function
0	:0	Measurement_Result (Result after linking, scaling, filter, etc.)
1	:1	Converted_Output_Value (Parallel output data after conversion)
2	:2	Frequency_1 (measured frequency - channel A without scaling)
3	:3	Frequency_2 (measured frequency - channel B without scaling)
4	:4	Counter (total count after linking without scaling, filters, etc.)
5	:5	Counter_A (counter reading - channel A)
6	:6	Counter_B (counter reading - channel B)
7	:7	SSI_Data (read + possibly converted binary SSI value)
8	:8	SSI_Calc_Result (SSI value incl. SSI zero and SSI offset without scaling, filters, etc.)
9	:9	Minimum_Value (Minimum value of Measurement_Result)
10	;0	Maximum_Value (Maximum value of Measurement_Result)
11	;1	Reserve
12	;2	Reserve
13	;3	Error Status (Reading the error code)
14	;4	SSI Read Value (readed, unconverted SSI value)
15	;5	SSI Loop Value (SSI value after round loop calculation)
16	;6	Actual Speed ()
17	;7	Actual Position (Start Stop: position [in μm] with offset without scaling)
18	;8	Actual Angle (Start Stop: e.g. angle with offset without scaling)
19	;9	Raw Position (Start Stop: position [in μm] without Offset and without scaling)

MODBUS

Value	Function
0	Serial interface uses the Lecom protocol
1 ... 247	-



Note

Modbus protocol cannot be selected via USB interface on this device.

4.7 Parallel Menu

In this menu the basic settings for the parallel output are defined. The parallel output always refers to the scaled "Measurement Result"!

PARALLEL MODE

Determines the output format of the parallel output and the source of the input data as follows:

Value	Designation	Function
0	BINARY	Parallel output format as binary code. Data source: "Measurement Result".
1	GRAY	Parallel output format as gray code. Data source: "Measurement Result".
2	BCD	Parallel output format as BCD code. Data source: „Measurement Result“.
3	BINARY	Parallel output format as binary code. Data source: „PARALLEL VALUE“.
4	GRAY	Parallel output format as gray code. Data source: „PARALLEL VALUE“.
5	BCD	Parallel output format as BCD code. Data source: „PARALLEL VALUE“.

PARALLEL INV.

Inversion of the data at the parallel output.

Value	Designation	Function
0	NORMAL	Data at the parallel output is output normally. Logic 1 corresponds to HIGH at parallel output Logic 0 corresponds to LOW at parallel output
1	INVERTED	Data at the parallel output is output inverted. Logic 1 corresponds to LOW at parallel output

Value	Designation	Function
		Logic 0 corresponds to HIGH at parallel output

PARALLEL VALUE

The value stored under this parameter appears directly at the parallel output if the "Parallel Mode" parameter was previously set to values greater than 2. The parameter has the serial access code "B1" and can be written via the serial interface.

This function can be useful for testing the outputs and the wiring:

Value	Function
-16777216	Smallest Value
0	Default Value
+16777215	Highest Value

PARALLEL UPDATE TIME (s)

Determines the refresh time of the parallel output.

Value	Function
0.001	Minimum update time in seconds
0.010	Default Value
9.999	Maximum update time in seconds

SPECIAL PIN FUNCTION

Determines the function of the 24. and 25. parallel output. (PIN24 + PIN25)

Value	Designation	Function
0	DATA & DATA	Pin 25 : Data output (Bit 25) Pin 24: Data output (Bit 24)
1	ERROR & DATA	Pin 25 : Error output (Active High) Pin 24: Data output (Bit 24)
2	/ERROR & DATA	Pin 25 : Error output (Active Low) Pin 24: Data output (Bit 24)
3	ERROR & /ERROR	Pin 25 : Error output (Active High) Pin 24: Error output (Active Low)
4	DATASTABLE & DATA	Pin 25 : Datastable output (Active High) Pin 24: Data output (Bit 24)
5	/DATASTABLE & DATA	Pin 25 : Datastable output (Active Low) Pin 24: Data output (Bit 24)
6	DATASTABLE & ERROR	Pin 25 : Datastable output (Active High) Pin 24: Error output (Active High)

Value	Designation	Function
7	DATASTABLE & /ERROR	Pin 25 : Dastable output (Active High) Pin 24: Error output (Active Low)
8	/DATASTABLE & ERROR	Pin 25 : Dastable output (Active Low) Pin 24: Error output (Active High)
9	/DATASTABLE & /ERROR	Pin 25 : Dastable output (Active Low) Pin 24: Error output (Active Low)
10	DATASTABLE & /DATASTABLE	Pin 25 : Dastable output (Active High) Pin 24: Dastable output (Active Low)

4.8 Command Menu

INPUT 1 ACTION (function input 1)

This parameter determines the control function of the input "Ctrl. In 1."

(s) = stat. switching characteristics (level modulation) → INPUT CONFIG must be set to ACTIVE LOW/HIGH.

(d) = dyn. switching characteristics (edge modulation) → INPUT CONFIG must be set to RISING/FALLING EDGE.

Value	Designation	Function	
0	NO	No function.	
1	RESET/SET VALUE	<p>Mode "SSI": Transfer of the currently detected position value (after bit suppression and possibly performed encoder zero offset shift) into the parameter "SSI offset" (display offset)</p> <p>Mode "Counter": Reset / set of both counter values (channel A and B) to the set values in SET VALUE A u. B</p> <p>Mode "Start/Stop": Power-failure-proof stored transfer of the current position or angle measurement to the "Offset" parameter.</p>	(d) (s)
2	FREEZE	Freezing of the current measurement result / of the parallel output	(s)
3	SSI ZERO POSITION	Mode "SSI" : Transfer of the current SSI position to the "SSI-Zero" parameter (encoder zero offset).	(d) (s)
4	RESET/SET COUNTER A	Mode "Counter" : Reset / Set the counter value of channel A to the set value in SET VALUE A.	(d) (s)

Value	Designation	Function	
5	RESET/SET COUNTER B	Mode "Counter" : Reset / Set the counter value of channel B to the set value in SET VALUE B.	(d) (s)
6	LOCK COUNTER A	Mode „Counter“ : Counter (channel A) is locked and does not count any further pulses as long as this command is present.	(s)
7	LOCK COUNTER B	Mode „Counter“ : Counter (channel B) is locked and does not count any further pulses as long as this command is present.	(s)
8	RESET MIN/MAX	Resetting the minimum / maximum value	(d) (s)
9	FACTORY SETTINGS	Device is reset to factory settings (pulse must be applied for at least one second!)	(s)

INPUT 1 CONFIG

This parameter determines the switching characteristics for "Ctrl. In 1."

Value	Designation	Function
0	ACTIVE LOW	Activates at "LOW" (static)
1	ACTIVE HIGH	Activates at "HIGH" (static)
2	RISING EDGE	Activates at rising edge (dynamic)
3	FALLING EDGE	Activates at falling edge (dynamic)

INPUT 2 ACTION

This parameter determines the control function of the input "Ctrl. In 2"

See function assignment for parameter INPUT 1 ACTION

INPUT 2 CONFIG

This parameter determines the switching characteristics for "Ctrl. In 2."

See activation assignment for parameter INPUT 1 CONFIG

INPUT 3 ACTION (FACTORY SETTINGS)

This parameter is preset to "Factory Settings" (resets device to factory settings) and cannot be changed.

INPUT 3 CONFIG (RISING EDGE)

This parameter is preset to "Rising Edge" and cannot be changed.

4.9 Linearization Menu

This menu defines the linearization points.

For a description and examples of the linearization function, see Appendix.

P1(X) ... P24(X)

X coordinate of the linearization points.

This is the value that the device would generate without linearization on the basis of the input signal.

Value	Function
-99999999	Smallest value
0	Default value
99999999	Largest value

P1(Y) ... P24(Y)

Y coordinate of the linearization points.

This is the value that the device should generate instead of the x coordinate.

For example: P2(X) is replaced by P2(Y).

Value	Function
-99999999	Smallest value
0	Default value
99999999	Largest value

5. Appendix

5.1 Reading Out Data via Serial Interface

The free operating software OS 6.0 is available at: Pepperl-Fuchs.com

The code positions (SERIAL VALUE) defined in the SERIAL MENU can be read out serially at any time by a PC or a PLC. Communication with this device is based on the Drivecom protocol according to ISO 1745 or the Modbus RTU protocol. For details, refer to the chapter "Modbus RTU Interface" in this manual. See Chapter 5.2.

The request string for reading out data is:

EOT	AD1	AD2	C1	C2	ENQ
-----	-----	-----	----	----	-----

EOT = control characters (hex 04)

AD1 = device address, high byte

AD2 = device address, low byte

C1 = code position to be read out, high byte

C2 = code position to be read out, low byte

ENQ = control characters (hex 05)

If, for example, the current display value is to be read out from a device with device address 11 (code = 1), the detailed request string will be as follows:

ASCII code:	EOT	1	1	:	1	ENQ
Hexadecimal:	04	31	31	3A	31	05
Binary:	0000 0100	0011 0001	0011 0001	0011 1010	0011 0001	0000 0101

If the request is correct, the response from the device is:

STX	C1	C2	xxxxx	ETX	BCC
-----	----	----	-------	-----	-----

STX = control characters (hex 02)

C1 = code position to be read out, high byte

C2 = code position to be read out, low byte

xxxxx = data to be read out

ETX = control characters (hex 03)

BCC = block check character

5.2 Parameter List / Serial Codes

#	Menu	Name	Code	Min.	Max.	Default
0	GENERAL MENU	MODE	00	0	4	0
1	GENERAL MENU	ENCODER PROPERTIES	01	0	4	0
2	GENERAL MENU	ENCODER DIRECTION	02	0	1	0
3	GENERAL MENU	FACTOR	03	-99999999	99999999	1
4	GENERAL MENU	DIVIDER	04	-99999999	99999999	1
5	GENERAL MENU	ADDITIVE VALUE	05	-99999999	99999999	0
6	GENERAL MENU	LINEARIZATION MODE	06	0	2	0
7	GENERAL MENU	BACKUP MEMORY	07	0	1	1
8	GENERAL MENU	FACTORY SETTINGS	08	0	1	0
9	GENERAL MENU	—	09	0	0	0
10	GENERAL MENU	—	10	0	0	0
11	MODE FREQUENCY	FREQUENCY MODE	11	0	5	0
12	MODE FREQUENCY	FREQUENCY BASE	12	0	3	2
13	MODE FREQUENCY	SAMPLING TIME 1 (s)	13	1	9999	100
14	MODE FREQUENCY	WAIT TIME 1 (s)	14	1	7999	100
15	MODE FREQUENCY	STANDSTILL TIME 1 (s)	15	1	9999	1
16	MODE FREQUENCY	AVERAGE FILTER 1	16	0	16	0
17	MODE FREQUENCY	SAMPLING TIME 2 (s)	17	1	9999	100
18	MODE FREQUENCY	WAIT TIME 2 (s)	18	1	7999	100
19	MODE FREQUENCY	AVERAGE FILTER 2	19	0	16	0
20	MODE FREQUENCY	—	20	0	0	0

#	Menu	Name	Code	Min.	Max.	Default
21	MODE FREQUENCY	—	21	0	0	0
22	MODE COUNTER	COUNT MODE	22	0	5	3
23	MODE COUNTER	FACTOR A	23	1	9999999	100000
24	MODE COUNTER	SET VALUE A	24	-99999999	99999999	0
25	MODE COUNTER	FACTOR B	25	1	9999999	100000
26	MODE COUNTER	SET VALUE B	26	-99999999	99999999	0
27	MODE COUNTER	ROUND LOOP VALUE	27	0	99999999	0
28	MODE COUNTER	—	28	0	0	0
29	MODE COUNTER	—	29	0	0	0
30	MODE SSI	SSI MODE	30	0	1	0
31	MODE SSI	ENCODER RESOLUTION	31	10	32	25
32	MODE SSI	DATA FORMAT	32	0	1	0
33	MODE SSI	BAUD RATE	33	0	5	2
34	MODE SSI	SSI ZERO	34	0	99999999 9	0
35	MODE SSI	HIGH BIT	35	1	32	25
36	MODE SSI	LOW BIT	36	1	32	1
37	MODE SSI	SSI OFFSET	37	0	99999999 9	0
38	MODE SSI	ROUND LOOP VALUE	38	0	99999999	0
39	MODE SSI	SAMPLING TIME (s)	39	1	9999	10
40	MODE SSI	ERROR BIT	40	0	32	0
41	MODE SSI	ERROR POLARITY	41	0	1	0
42	MODE SSI	—	42	0	0	0
43	MODE SSI	—	43	0	0	0
44	MODE START/STOP	INIT MODE	44	0	1	0
45	MODE START/STOP	SAMPLING TIME (ms)	45	200	16000	4000
46	MODE START/STOP	INIT PULSE TIME (μs)	46	1	9	2

#	Menu	Name	Code	Min.	Max.	Default
47	MODE START/STOP	VELOCITY (m/s)	47	100	999999	280000
48	MODE START/STOP	OPERATIONAL MODE	48	0	2	0
49	MODE START/STOP	OFFSET	49	-99999999	99999999	0
50	MODE START/STOP	CIRCUMFERENCE (mm)	50	1	99999999	100000
51	MODE START/STOP	ROUND LOOP VALUE	51	1	99999999	360
52	MODE START/STOP	AVERAGE FILTER - POSITION	52	0	4	0
53	MODE START/STOP	STANDSTILL TIME (s)	53	1	9999	1
54	MODE START/STOP	AVERAGE FILTER - SPEED	A0	0	4	0
55	MODE START/STOP	—	A1	0	0	0
56	MODE START/STOP	—	A2	0	0	0
57	SERIAL MENU	UNIT NUMBER	90	11	11	11
58	SERIAL MENU	SERIAL BAUD RATE	91	3	3	3
59	SERIAL MENU	SERIAL FORMAT	92	8	8	8
60	SERIAL MENU	SERIAL INIT	9~	1	1	1
61	SERIAL MENU	SERIAL PROTOCOL	A3	0	1	0
62	SERIAL MENU	SERIAL TIMER (S)	A4	0	60000	0
63	SERIAL MENU	SERIAL VALUE	A5	0	19	0
64	SERIAL MENU	MODBUS	A6	0	0	0
65	SERIAL MENU	—	A7	0	0	0
66	SERIAL MENU	—	A8	0	0	0
67	PARALLEL MENU	PARALLEL MODE	A9	0	5	0
68	PARALLEL MENU	PARALLEL INV.	B0	0	1	0
69	PARALLEL MENU	PARALLEL VALUE	B1	-16777216	16777215	0
70	PARALLEL MENU	PARALLEL UPDATE TIME (s)	B2	1	9999	10

#	Menu	Name	Code	Min.	Max.	Default
71	PARALLEL MENU	SPECIAL PIN FUNCTION	B3	0	10	0
72	COMMAND MENU	INPUT 1 ACTION	B4	0	9	0
73	COMMAND MENU	INPUT 1 CONFIG.	B5	0	3	2
74	COMMAND MENU	INPUT 2 ACTION	B6	0	9	0
75	COMMAND MENU	INPUT 2 CONFIG.	B7	0	3	2
76	COMMAND MENU	INPUT 3 ACTION (FACTORY SETTINGS)	B8	9	9	9
77	COMMAND MENU	INPUT 3 CONFIG. (ACTIVE HIGH)	B9	2	2	2
78	COMMAND MENU	—	C0	0	0	0
79	COMMAND MENU	—	C1	0	0	0
80	LINEARIZATION MENU	P1(X)	C2	-99999999	99999999	0
81	LINEARIZATION MENU	P1(Y)	C3	-99999999	99999999	0
82	LINEARIZATION MENU	P2(X)	C4	-99999999	99999999	0
83	LINEARIZATION MENU	P2(Y)	C5	-99999999	99999999	0
84	LINEARIZATION MENU	P3(X)	C6	-99999999	99999999	0
85	LINEARIZATION MENU	P3(Y)	C7	-99999999	99999999	0
86	LINEARIZATION MENU	P4(X)	C8	-99999999	99999999	0
87	LINEARIZATION MENU	P4(Y)	C9	-99999999	99999999	0
88	LINEARIZATION MENU	P5(X)	D0	-99999999	99999999	0
89	LINEARIZATION MENU	P5(Y)	D1	-99999999	99999999	0
90	LINEARIZATION MENU	P6(X)	D2	-99999999	99999999	0

#	Menu	Name	Code	Min.	Max.	Default
91	LINEARIZATION MENU	P6(Y)	D3	-99999999	99999999	0
92	LINEARIZATION MENU	P7(X)	D4	-99999999	99999999	0
93	LINEARIZATION MENU	P7(Y)	D5	-99999999	99999999	0
94	LINEARIZATION MENU	P8(X)	D6	-99999999	99999999	0
95	LINEARIZATION MENU	P8(Y)	D7	-99999999	99999999	0
96	LINEARIZATION MENU	P9(X)	D8	-99999999	99999999	0
97	LINEARIZATION MENU	P9(Y)	D9	-99999999	99999999	0
98	LINEARIZATION MENU	P10(X)	E0	-99999999	99999999	0
99	LINEARIZATION MENU	P10(Y)	E1	-99999999	99999999	0
100	LINEARIZATION MENU	P11(X)	E2	-99999999	99999999	0
101	LINEARIZATION MENU	P11(Y)	E3	-99999999	99999999	0
102	LINEARIZATION MENU	P12(X)	E4	-99999999	99999999	0
103	LINEARIZATION MENU	P12(Y)	E5	-99999999	99999999	0
104	LINEARIZATION MENU	P13(X)	E6	-99999999	99999999	0
105	LINEARIZATION MENU	P13(Y)	E7	-99999999	99999999	0
106	LINEARIZATION MENU	P14(X)	E8	-99999999	99999999	0
107	LINEARIZATION MENU	P14(Y)	E9	-99999999	99999999	0
108	LINEARIZATION MENU	P15(X)	F0	-99999999	99999999	0

#	Menu	Name	Code	Min.	Max.	Default
109	LINEARIZATION MENU	P15(Y)	F1	-99999999	99999999	0
110	LINEARIZATION MENU	P16(X)	F2	-99999999	99999999	0
111	LINEARIZATION MENU	P16(Y)	F3	-99999999	99999999	0
112	LINEARIZATION MENU	P17(X)	F4	-99999999	99999999	0
113	LINEARIZATION MENU	P17(Y)	F5	-99999999	99999999	0
114	LINEARIZATION MENU	P18(X)	F6	-99999999	99999999	0
115	LINEARIZATION MENU	P18(Y)	F7	-99999999	99999999	0
116	LINEARIZATION MENU	P19(X)	F8	-99999999	99999999	0
117	LINEARIZATION MENU	P19(Y)	F9	-99999999	99999999	0
118	LINEARIZATION MENU	P20(X)	G0	-99999999	99999999	0
119	LINEARIZATION MENU	P20(Y)	G1	-99999999	99999999	0
120	LINEARIZATION MENU	P21(X)	G2	-99999999	99999999	0
121	LINEARIZATION MENU	P21(Y)	G3	-99999999	99999999	0
122	LINEARIZATION MENU	P22(X)	G4	-99999999	99999999	0
123	LINEARIZATION MENU	P22(Y)	G5	-99999999	99999999	0
124	LINEARIZATION MENU	P23(X)	G6	-99999999	99999999	0
125	LINEARIZATION MENU	P23(Y)	G7	-99999999	99999999	0
126	LINEARIZATION MENU	P24(X)	G8	-99999999	99999999	0

#	Menu	Name	Code	Min.	Max.	Default
127	LINEARIZATION MENU	P24(Y)	G9	-999999999	999999999	0

5.3 Serial Codes of the Commands

Serial code	Command
54	RESET/SET
55	FREEZE DISPLAY
56	SSI ZERO POSITION
57	RESET/SET COUNTER A
58	RESET/SET COUNTER B
59	LOCK COUNTER A
60	LOCK COUNTER B
61	RESET MIN/MAX
62	FACTORY SETTINGS
63	-
64	-
65	CLEAR LOOP TIME
66	SERIAL PRINT
67	ACTIVATE DATA
68	STORE DATA
69	TESTPROGRAM

5.4 Linearization

This function can be used to convert a linear input signal into a non-linear representation (or vice versa). Up to 24 linearization points are available, which can be distributed over the entire conversion range at various distances.

Linear interpolation takes place automatically between two predefined coordinates.

It is recommended that as many points as possible be positioned in places with strong curvature. In places with weak curvature, only a few points are needed.

To specify a linearization curve, the LINEARIZATION MODE parameter must be set to

1 QUADRANT or 4 QUADRANT (see diagram below).

Parameters P1(X) to P24(X) can be used to specify up to 24 X coordinates.

These correspond to display values without linearization.

Parameters P1(Y) to P24(Y) are used to enter the values that the measured value is to assume instead of the X values.

For example, the value P5(X) is replaced by the value P5(Y).

The X coordinates must be assigned continuously increasing values.

P1(X) is the smallest value and each of the following must be greater. For measured values greater than the last defined X value, the corresponding Y value is used constantly.

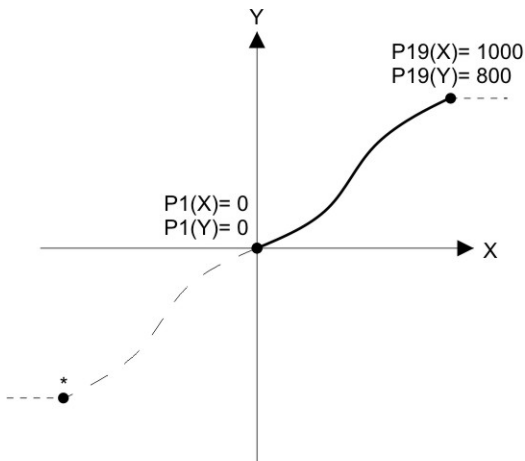

Example: Linearization Mode: 1 Quadrant

* Linearization is point symmetric to 1. Quadrant

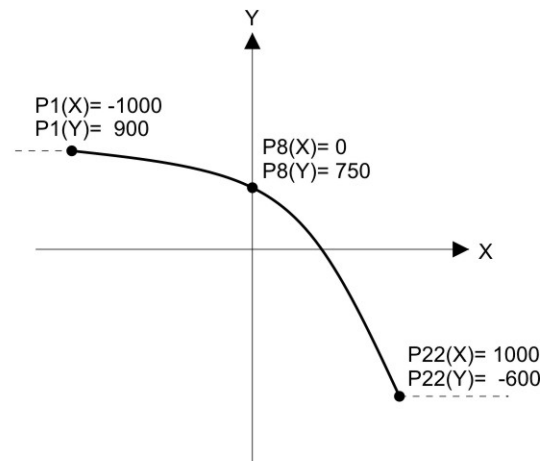

Example: Linearization Mode: 4 Quadrant

Mode: 1 Quadrant:

P1(X) must be set to 0. The linearization is only defined in the positive value range.

In the case of negative measured values, the curve is mirrored point-symmetrically.

Mode: 4 Quadrant:

P1(X) can also be set to negative values. For measured values less than P1(X), the P1(Y) value is used constantly.

Linearization application example:

The image below shows a water lock, in which the opening width is detected by a rotary encoder and displayed. In this arrangement, the rotary encoder generates a signal proportional to the angle of rotation φ . However, a direct indication of the opening width "d" is desired.

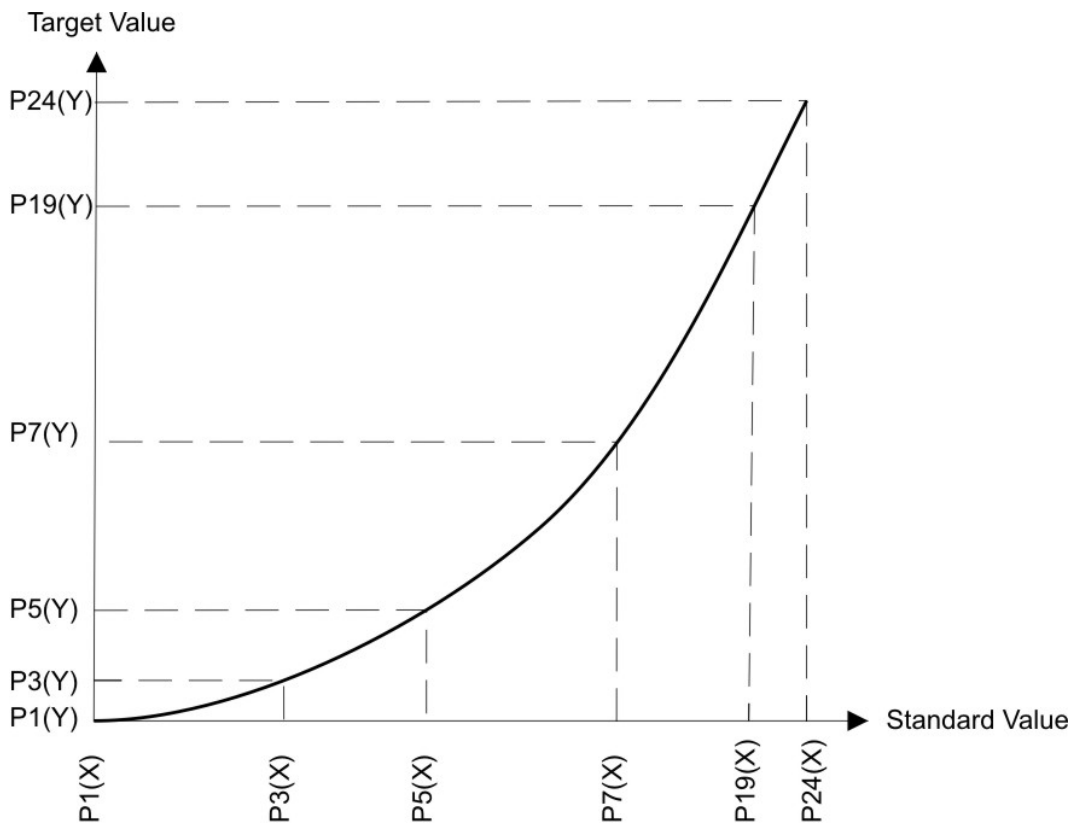
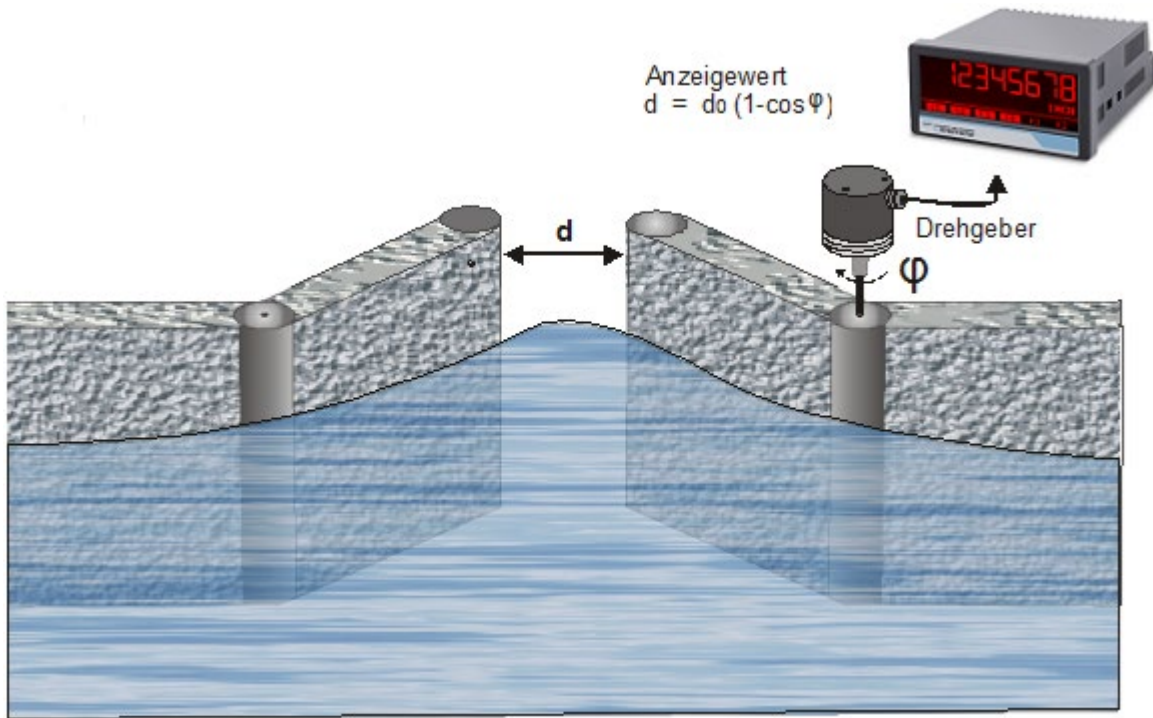

5.5 Reading in the SSI Value

The received data is always filled internally to a 32-bit data length.

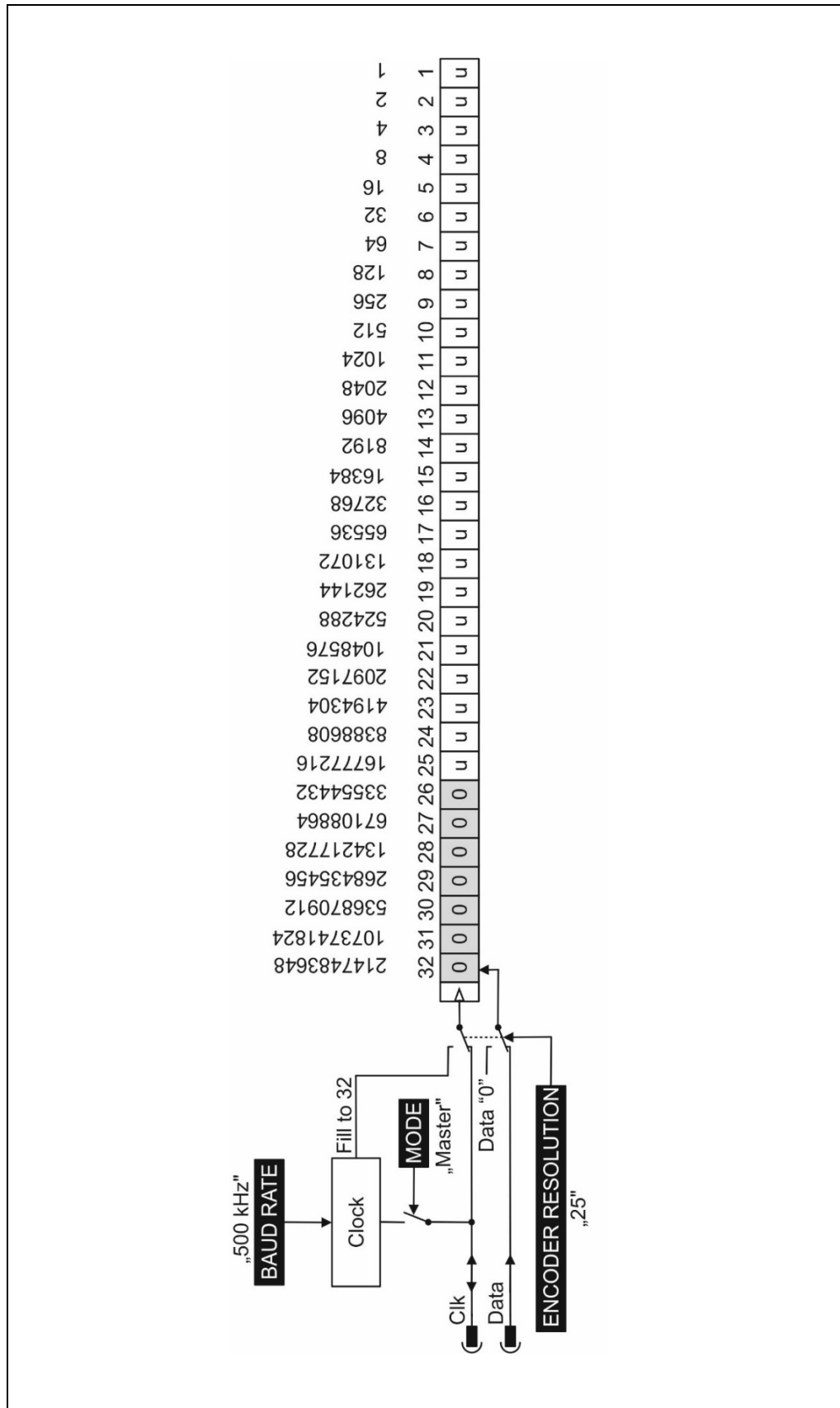

Internal processing and calculation of SSI data

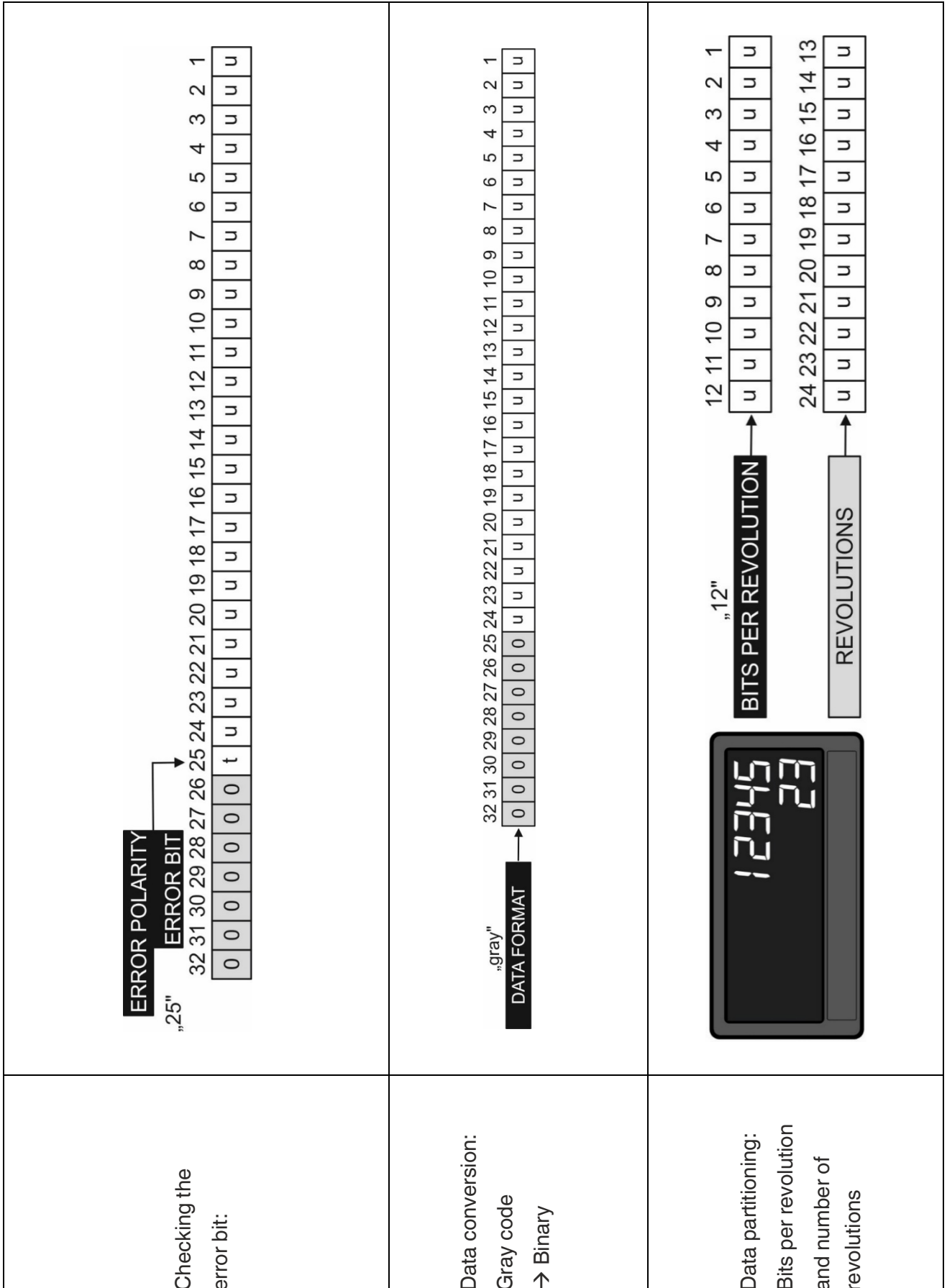

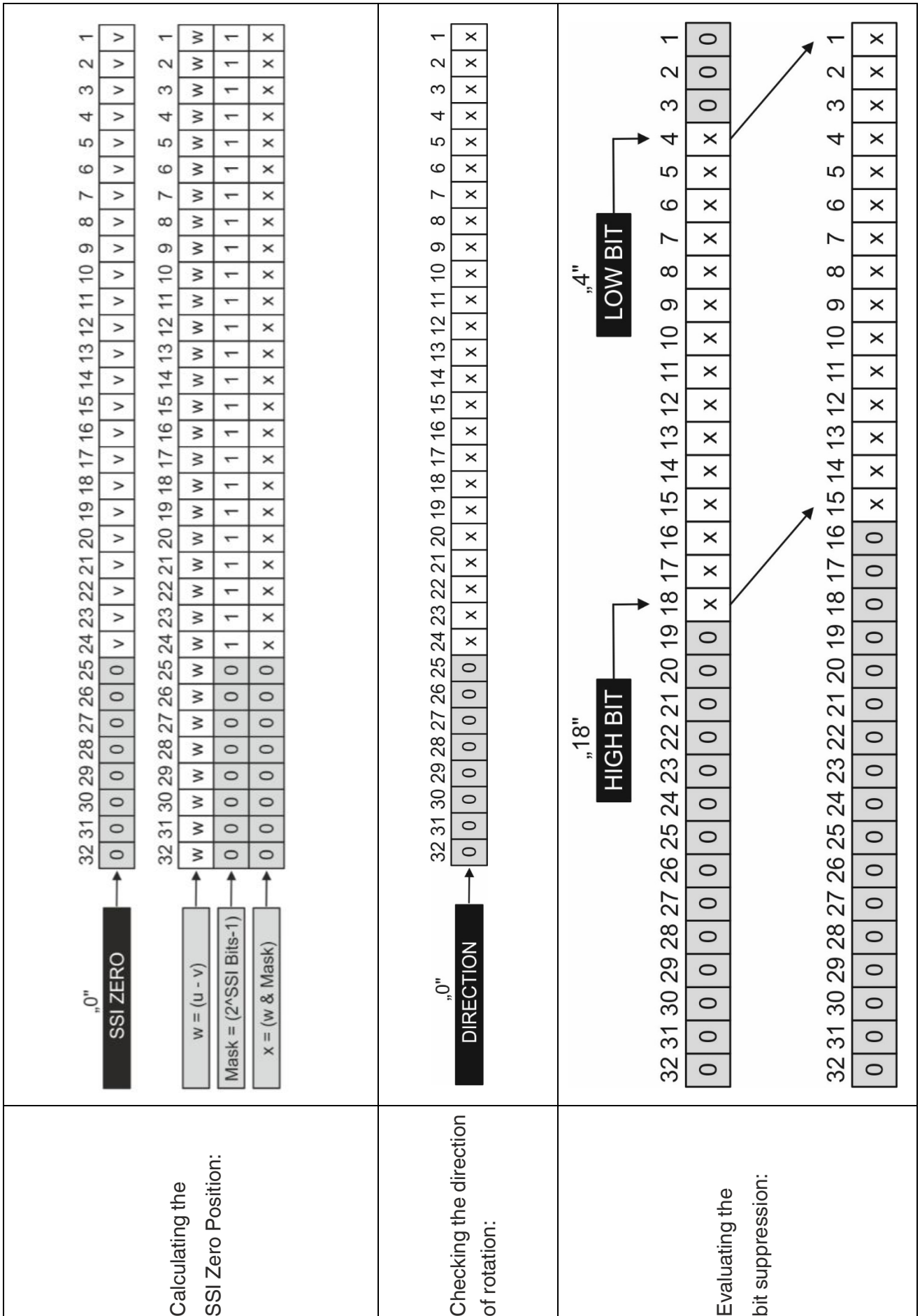

Calculating the SSI Zero Position:

Checking the direction of rotation:

Evaluating the bit suppression:

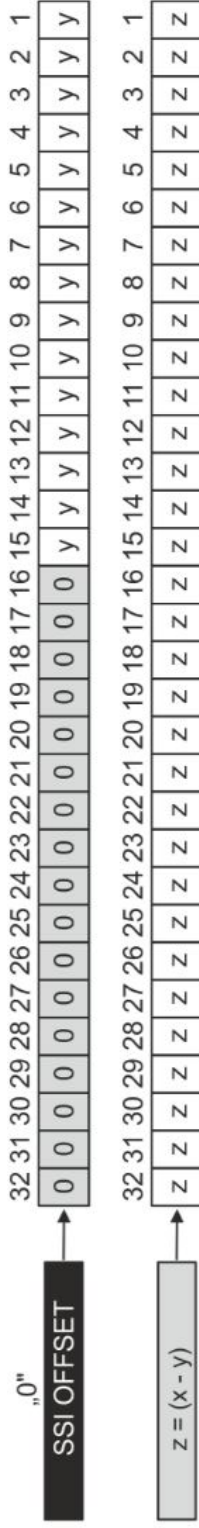
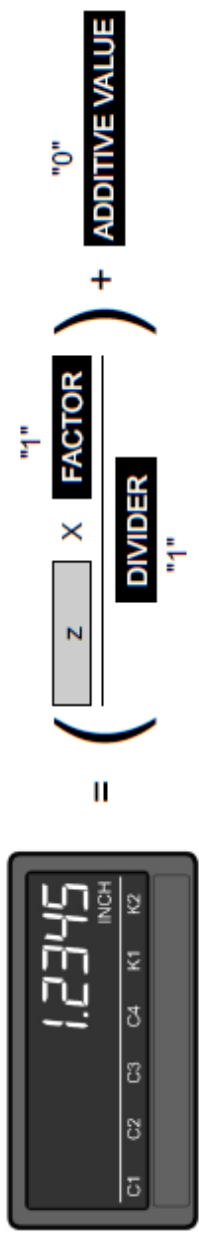
<p>Calculating the SSI offset:</p>	 <p>Diagram illustrating the calculation of the SSI offset. It shows two rows of data points (bits) indexed from 32 to 1. The first row, labeled "0" and SSI OFFSET, contains 0s from bit 32 to 20, followed by 0s from bit 19 to 1. The second row, labeled z = (x - y), contains z values from bit 32 to 1. An arrow points from the SSI OFFSET label to the first row.</p>
<p>Calculating the display value:</p>	 <p>Diagram illustrating the calculation of the display value. A digital display shows 1.2345 INCH. Below it is the formula: $\left(\frac{z}{\text{DIVIDER}} \right) \times \text{FACTOR} + \text{ADDITIVE VALUE}$</p>

5.6 Operating Modes / OP Modes of the Start/Stop Interface

The device supports the following operating modes:

Managing Operation

- The device generates the init pulse for a connected rotary encoder.
- The two init connectors (INIT OUT, /INIT OUT) are configured as outputs.

Managed Operation

- An external device generates the init pulse for a rotary encoder.
- The two init connectors (ext. INIT IN, ext. /INIT IN) are configured as inputs.

The desired operating mode can be selected in the "General Menu" using the "INIT MODE" parameter.

The device can also be operated in the following three "Operational Modes." The desired measuring function (distance measurement, angle measurement, or velocity measurement) can be selected using the "OPERATIONAL MODE" parameter.

POSITION (distance measurement)

The current position of the position encoder is determined on the basis of a run-time measurement from the start and stop pulse and can be converted into another unit using existing scaling parameters (factor, divider, and additive value), e.g., for the serial readout of the position value in a desired unit.

Interpretation of the measurement result for the distance measurement:

The default setting of the scaling parameters ("FACTOR = 1," "DIVIDER = 1" and "ADDITIVE VALUE = 0") is a position measurement result in micrometers (μm).

For example, to get a position in inches with three notional decimal places, the "FACTOR" parameter must be set to "10," the "DIVIDER" parameter to "254," and the "ADDITIVE VALUE" parameter to "0."

ANGLE (angle measurement)

For angle measurement, the desired position or angle output value per revolution can be specified using the "ROUND LOOP VALUE" parameter. This output value is generated as soon as the distance traveled (e.g., circumference), which is set as the reference quantity in the "CIRCUMFERENCE (in mm)" parameter, is reached. The output value then starts again at 0 until the distance traveled is reached again. (Round Loop function!)

Using existing scaling parameters (factor, divider, and additive value), this output value can be rescaled if desired.

Interpretation of the measurement result for the angle measurement:

The default setting ("CIRCUMFERENCE [mm] = 100,000" and "ROUND LOOP VALUE = 360," and "FACTOR = 1," "DIVIDER = 1" and "ADDITIVE VALUE = 0") is an angle or position output of "0 ... 360" (e.g., degrees) every 100,000 mm.

SPEED (velocity measurement)

The velocity is detected and can be converted to another unit using existing scaling parameters (factor, divider, and additive value), if desired.

Interpretation of the measurement result for the velocity measurement:

The default setting ("FACTOR = 1," "DIVIDER = 1" and "ADDITIVE VALUE = 0") is a velocity output in meters per second [m/s].



Note

The parallel output and the linearization function always refer to the scaled measuring result of the selected operational mode! (Measurement_Result)

5.7 Dimensions

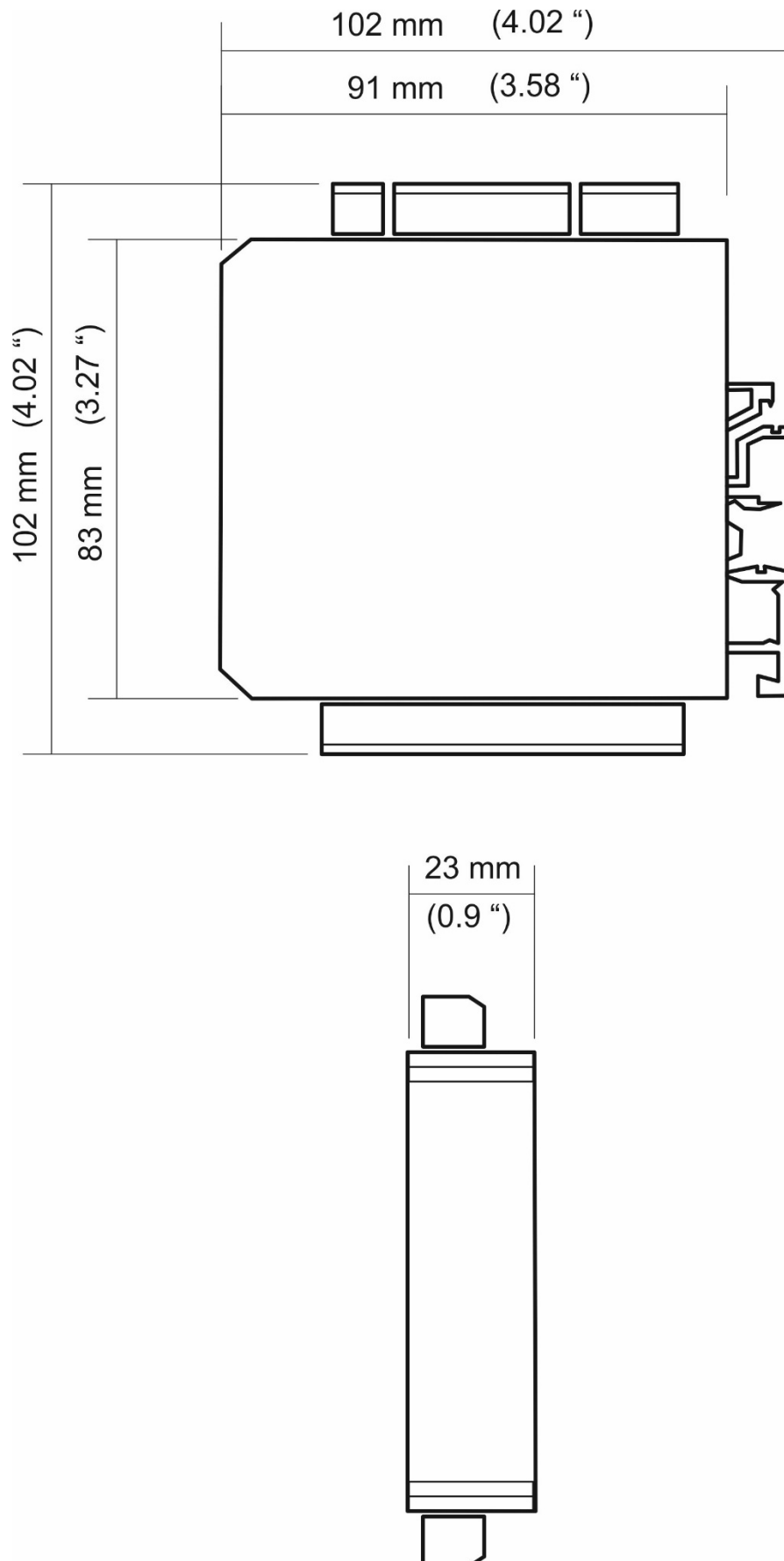

Your automation, our passion.

Explosion Protection

- Intrinsic Safety Barriers
- Signal Conditioners
- FieldConnex® Fieldbus
- Remote I/O Systems
- Electrical Ex Equipment
- Purge and Pressurization
- Industrial HMI
- Mobile Computing and Communications
- HART Interface Solutions
- Surge Protection
- Wireless Solutions
- Level Measurement

Industrial Sensors

- Proximity Sensors
- Photoelectric Sensors
- Industrial Vision
- Ultrasonic Sensors
- Rotary Encoders
- Positioning Systems
- Inclination and Acceleration Sensors
- Fieldbus Modules
- AS-Interface
- Identification Systems
- Displays and Signal Processing
- Connectivity

Pepperl+Fuchs Quality
Download our latest policy here:

www.pepperl-fuchs.com/quality

