With regard to the supply of products, the current issue of the following document is applicable:
The General Terms of Delivery for Products and Services of the Electrical Industry, published by the Central Association of the Electrical Industry (Zentralverband Elektrotechnik und Elektroindustrie (ZVEI) e.V.) in its most recent version as well as the supplementary clause: "Expanded reservation of proprietorship"

Worldwide

Pepperl+Fuchs Group
Lilienthalstr. 200
68307 Mannheim
Germany
Phone: +49 621 776 - 0
E-mail: info@de.pepperl-fuchs.com

North American Headquarters

Pepperl+Fuchs Inc.
1600 Enterprise Parkway
Twinsburg, Ohio 44087
USA
Phone: +1 330 425-3555
E-mail: sales@us.pepperl-fuchs.com

Asia Headquarters

Pepperl+Fuchs Pte. Ltd.
P+F Building
18 Ayer Rajah Crescent
Singapore 139942
Phone: +65 6779-9091
E-mail: sales@sg.pepperl-fuchs.com
<https://www.pepperl-fuchs.com>

1	Introduction	5
2	Terminology and Abbreviations	6
3	Intended Use	8
4	Installation Instructions	9
5	AC Input	11
6	DC Input	13
7	Input Inrush Current	14
8	Output	15
9	Hold-Up Time	17
10	DC-OK Relay Contact	18
11	Efficiency and Power Losses	19
12	Lifetime Expectancy	21
13	MTBF	22
14	Functional Diagram	23
15	Terminals and Wiring	24
16	Replacing Units while the System is Running	25
17	Front Side and User Elements	26
18	EMC	27
19	Environment	29
20	Safety and Protection Features	31
21	Dielectric Strength	32
22	Approvals	33
23	Other Fulfilled Standards	34
24	Physical Dimensions and Weight	35
25	Application Notes	36

1 Introduction

The information given in this document is correct to the best of our knowledge and experience at the time of publication. If not expressly agreed otherwise, this information does not represent a warranty in the legal sense of the word. As the state of our knowledge and experience is constantly changing, the information in this data sheet is subject to revision. We therefore kindly ask you to always use the latest issue of this document.

No part of this document may be reproduced or utilized in any form without our prior permission in writing.

2 Terminology and Abbreviations

PE and \oplus symbol	PE is the abbreviation for Protective Earth and has the same meaning as the symbol \oplus .
Earth, Ground	This document uses the term earth which is the same as the U.S. term ground .
T.b.d.	To be defined, value or description will follow later.
AC 230V	A figure displayed with the AC or DC before the value represents a nominal voltage with standard tolerances (usually $\pm 15\%$) included. E.g.: DC 12V describes a 12V battery disregarding whether it is full (13.7V) or flat (10V)
230Vac	A figure with the unit (Vac) at the end is a momentary figure without any additional tolerances included.
50Hz vs. 60Hz	As long as not otherwise stated, AC 230V parameters are valid at 50Hz mains frequency.
may	A key word indicating flexibility of choice with no implied preference.
shall	A key word indicating a mandatory requirement.
should	A key word indicating flexibility of choice with a strongly preferred implementation.
1+1 Redundancy	Use of two identical power supplies in parallel to provide continued operation following most failures in a single power supply. The two power supply outputs should be isolated from each other by utilizing diodes or other switching arrangements. E.g. two 20A power supplies are needed to achieve a 20A redundant system.
N+1 Redundancy	Use of three or more identical power supplies in parallel to provide continued operation following most failures in a single power supply. All power supply outputs should be isolated from each other by utilizing diodes or other switching arrangements. E.g.: To achieve a 80A redundant system, five 20A power supplies are needed in a N+1 redundant system.

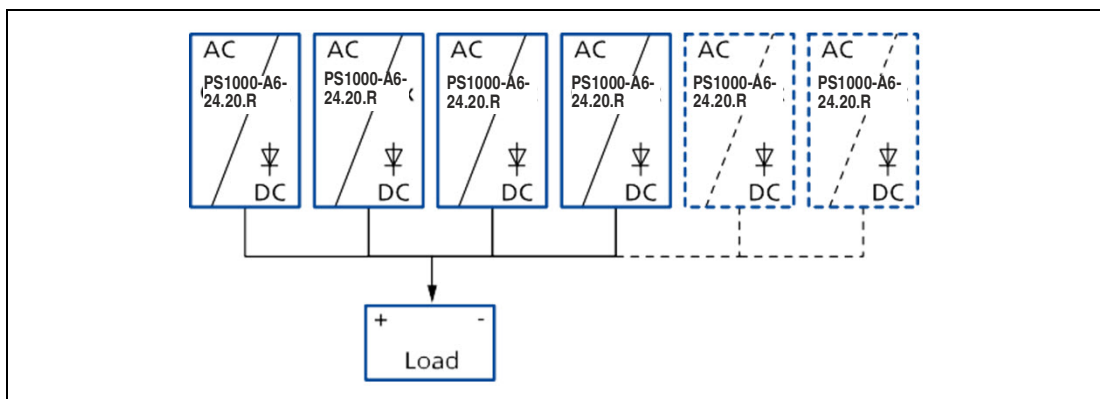

Figure 2.1 N+1 Redundancy

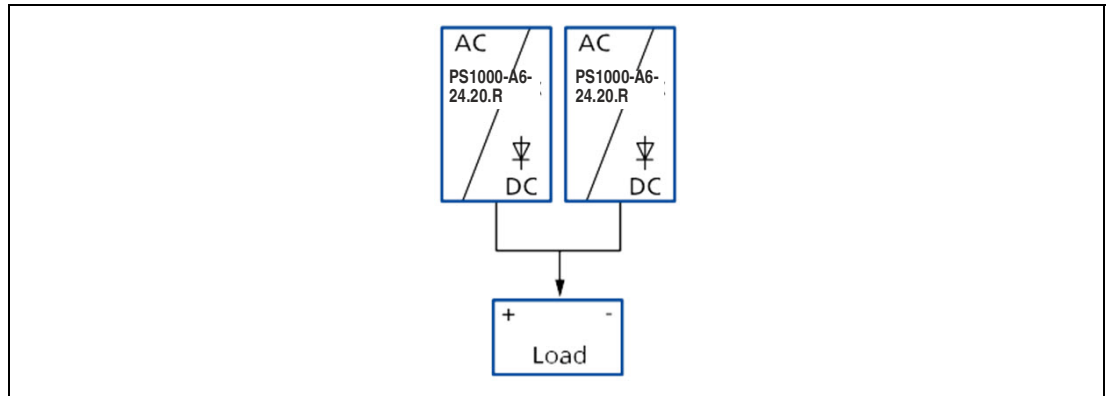

Figure 2.2 1+1 Redundancy

3 Intended Use

This device is designed for installation in an enclosure and is intended for the general professional use such as in industrial control, office, communication, and instrumentation equipment.

Do not use this power supply in equipment, where malfunction may cause severe personal injury or threaten human life.

Function

The device is used to supply field devices with 24 V DC and 20 A.

The device includes a decoupling MOSFET for building 1+1 or n+1 redundant power supply systems.

To achieve current sharing between power supplies connected in parallel, the device is permanently factory-set to **parallel use** operating mode.

The device status is indicated by an LED.

The device has a relay contact output for remote monitoring.

The device is mounted on a 35 mm DIN mounting rail according to EN 60715.

Reference Conditions

All parameters are typical values specified at 230Vac, 50Hz input voltage, 24V, 20A output load, 25°C ambient and after a 5 minutes run-in time unless otherwise noted.

4 Installation Instructions



Warning!

Risk of electrical shock, fire, personal injury or death.

- Do not use the power supply without proper grounding (Protective Earth). Use the terminal on the input block for earth connection and not one of the screws on the housing.
- Turn power off before working on the device. Protect against inadvertent re-powering.
- Make sure that the wiring is correct by following all local and national codes.
- Do not modify or repair the unit.
- Do not open the unit as high voltages are present inside.
- Use caution to prevent any foreign objects from entering the housing.
- Do not use in wet locations or in areas where moisture or condensation can be expected.
- Do not touch during power-on, and immediately after power-off. Hot surfaces may cause burns.



Warning!

Explosion hazards

- Substitution of components may impair suitability for this environment.
- Do not disconnect the unit or operate the voltage adjustment unless power has been switched off or the area is known to be non-hazardous.
- Wiring must be in accordance with Class I, Division 2 wiring methods of the National Electrical Code, NFPA 70, and in accordance with other local or national codes.
- A suitable enclosure must be provided for the end product which has a minimum protection of IP54 and fulfills the requirements of the EN 60079-0.



Note

If you use the device in hazardous areas, observe the safety information in the instruction manual and in chapter 22.

This device may only be installed and put into operation by qualified personnel.

Install the device in an enclosure providing protection against electrical, mechanical and fire hazards.

The device is designed for use in pollution degree 2 areas in controlled environments.

The enclosure of the device provides a degree of protection of IP20 according to IEC 60529.

Mount the unit on a DIN-rail so that the input terminals are located on the bottom of the unit. For other mounting orientations see de-rating requirements in this document.

The device is designed for convection cooling and does not require an external fan. Do not obstruct airflow and do not cover ventilation grid (e.g., cable conduits) by more than 15%.

Keep the following installation clearances: 40mm on top, 20mm on the bottom, 5mm on the left and right side are recommended when the device is loaded permanently with more than 50% of the rated power. Increase this clearance to 15mm in case the adjacent device is a heat source (Example: another power supply).

Make sure that the wiring is correct by following all local and national codes. Use appropriate copper cables that are designed for a minimum operating temperature of 60°C for ambient temperatures up to +45°C, 75°C for ambient temperatures up to +60°C and 90°C for ambient temperatures up to +70°C. Ensure that all strands of a stranded wire enter the terminal connection. Check also local codes and local requirements. In some countries local regulations might apply.

This device does not contain serviceable parts. The tripping of an internal fuse is caused by an internal defect. If damage or malfunction should occur during installation or operation, immediately turn power off and send the device to the factory for inspection.

The device is designed, tested and approved for branch circuits up to up to 30A (UL) or 32A (IEC) without additional protection device. If an external fuse is utilized, do not use circuit breakers smaller than 10A B- or C-Characteristic to avoid a nuisance tripping of the circuit breaker.

A disconnecting means shall be provided for the input of the power supply.

5 AC Input

The device is suitable to be supplied from TN-, TT- or IT-mains networks with AC voltage. For suitable DC supply voltages see chapter 6.

AC input AC input range	nom. min. max.	AC 100-240V 85-264Vac 264-300Vac	Continuous operation Occasionally for maximal 500ms
Allowed voltage L or N to earth	max.	300Vac	Continuous, according to IEC 62477-1
Input frequency	nom.	50-60Hz	±6%
Turn-on voltage	typ.	82Vac	Steady-state value, see Figure 5.1
Shut-down voltage	typ.	72Vac	Steady-state value, see Figure 5.1
External input protection	See recommendations in chapter 4.		

		AC 100V	AC 120V	AC 230V	
Input current	typ.	5.17A	4.28A	2.25A	At 20A, see Figure 5.3
Power factor	typ.	0.996	0.996	0.980	At 20A, see Figure 5.4
Crest factor	typ.	1.65	1.63	1.63	At 20A, The crest factor is the mathematical ratio of the peak value to RMS value of the input current waveform.
Start-up delay	typ.	450ms	450ms	450ms	See Figure 5.2
Rise time	typ.	145ms	145ms	145ms	At 20A const. current load, 0mF load capacitance, see Figure 5.2
	typ.	160ms	160ms	160ms	At 20A const. current load, 20mF load capacitance, see Figure 5.2.
Turn-on overshoot	max.	1000mV	1000mV	1000mV	see Figure 5.2

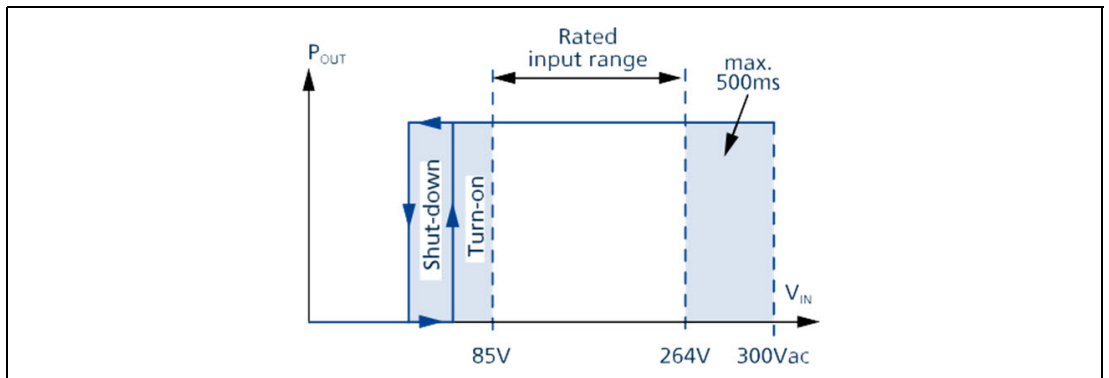

Figure 5.1 Input voltage range

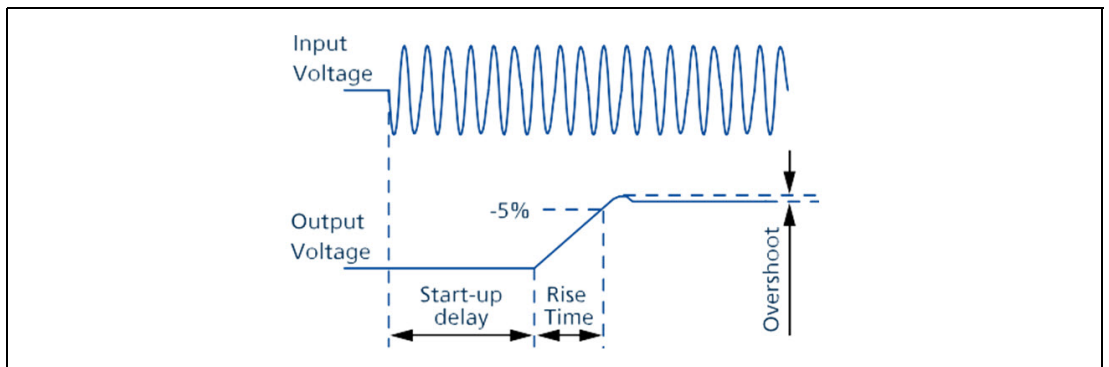

Figure 5.2 Turn-on behavior, definitions

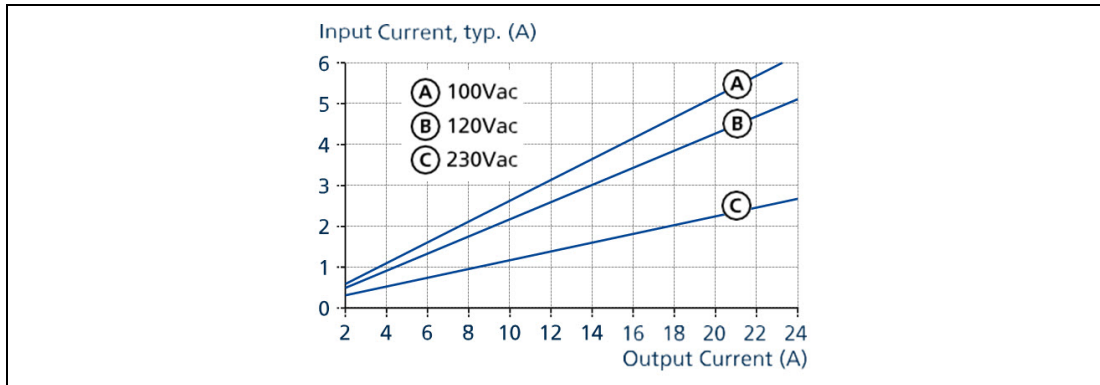

Figure 5.3 Input current vs. output current

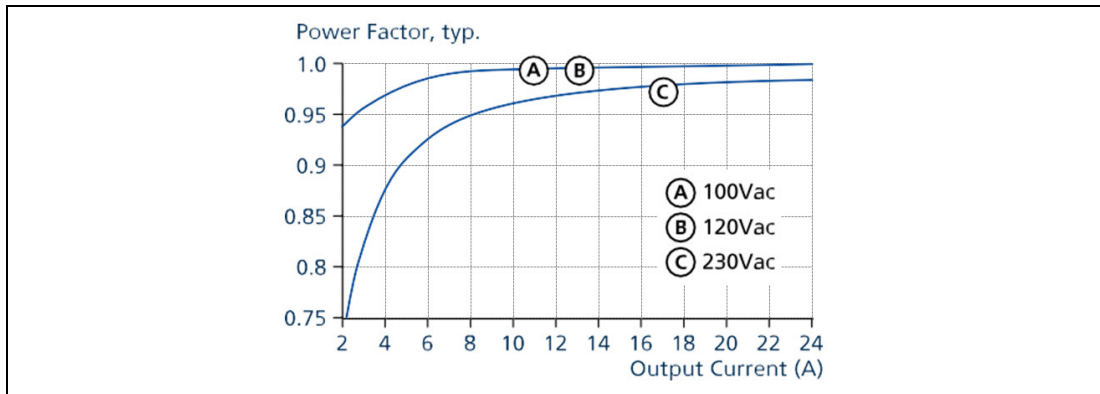

Figure 5.4 Power factor vs. output current

6 DC Input

DC input	Nom.	DC 110-150V	±20%
DC input range	Min.	88-180Vdc	Continuous operation
DC input current	Typ.	4.64A	At 110Vdc and 20A load current
Allowed Voltage (+) or (-) input to earth	Max.	375Vdc	Continuous, according to IEC 62477-1
Turn-on voltage	Typ.	80Vdc	Steady state value
Shut-down voltage	Typ.	70Vdc	Steady state value

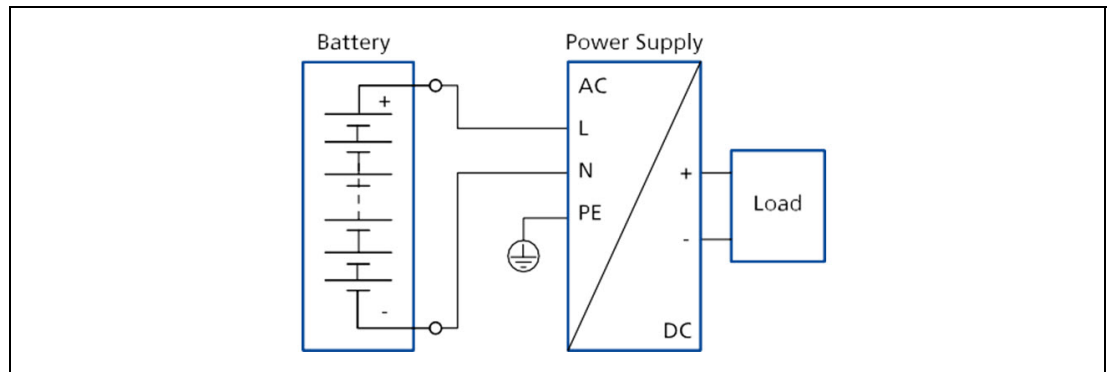

Figure 6.1 Wiring for DC Input

The device is suitable to be supplied from a DC input voltage.



Using DC

1. Use a battery or a similar DC source. A supply from the intermediate DC bus of a frequency converter is not recommended and can cause a malfunction or damage the unit.
2. Connect (+) pole to L and (-) pole to N.
3. Connect the PE terminal to an earth wire or to the machine ground.

7 Input Inrush Current

An active inrush limitation circuit limits the input inrush current after turn-on of the input voltage.

The charging current into EMI suppression capacitors is disregarded in the first microseconds after switch-on.

		AC 100V	AC 120V	AC 230V	
Inrush current	Max.	15A _{peak}	12A _{peak}	5.5A _{peak}	Temperature independent
	Typ.	12A _{peak}	10A _{peak}	4.5A _{peak}	Temperature independent
Inrush energy	Max.	1A ² s	1A ² s	1A ² s	Temperature independent

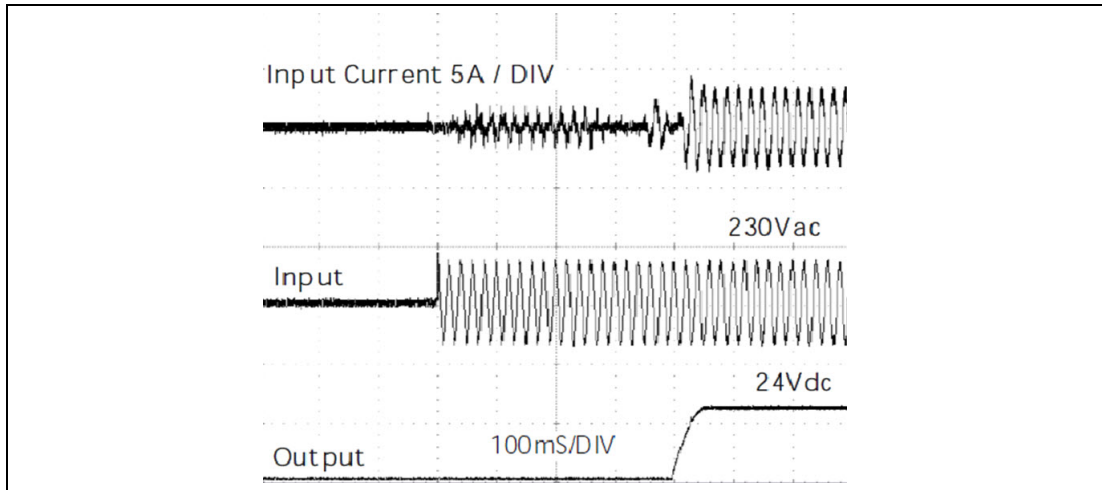

Figure 7.1 Typical turn-on behavior at nominal load and 25°C ambient

8 Output

The output provides a SELV/PELV/ES1 rated voltage, which is galvanically isolated from the input voltage. The output of the devices includes a decoupling MOSFET for building 1+1 or N+1 redundant power supply systems.

The device is designed to supply any kind of loads, including capacitive and inductive loads. If extreme large capacitors, such as EDLCs (electric double layer capacitors or **UltraCaps**) with a capacitance >1F are connected to the output, the unit might charge the capacitor in the **Hiccup** mode.

The device is featured with a **soft output regulation characteristic** in order to achieve current share between multiple devices when they are connected in parallel. The **soft output regulation characteristic** regulates the output voltage in such a manner that the voltage at no load is approx. 4% higher than at nominal load.

Output voltage	nom.	DC 24V	23.8 - 25.2V
Adjustment range		see chapter 26.2	
Factory settings		24.1V	$\pm 0.2\%$, at 20A, cold unit (results to typ. $23.9V^{\pm 0.2\%}$ at 24A and typ. $25.1V^{\pm 0.2\%}$ at no load)
Line regulation	max.	10mV	85-300Vac
Load regulation	typ.	1000mV	Static value, 0A → 20A; see Figure 8.1
Ripple and noise voltage	max.	100mV _{pp}	20Hz to 20MHz, 50Ohm
Output current	nom.	24A ¹	Below +45°C ambient temperature, see Figure 19.1
	nom.	20A	At +60°C ambient temperature, see Figure 19.1
	nom.	15A	At +70°C ambient temperature, see Figure 19.1
Fuse breaking current ²	typ.	60A	Up to 12ms once every five seconds, see Figure 8.3
Overload protection	Included		Electronically protected against overload, no-load and short-circuits. In case of a protection event, audible noise may occur.
Overload behavior	Continuous current		For output voltage above 13Vdc, see Figure 8.1
	Intermitted current ³		For output voltage below 13Vdc, see Figure 8.1
Overload/short-circuit current	max.	29.8A	Continuous current, see Figure 8.1
	typ.	29A	Intermitted current peak value for typ. 2s Load impedance 10mOhm, see Figure 8.2. Discharge current of output capacitors is not included.
	max.	9.8A	Intermitted current average value (R.M.S.) Load impedance 10mOhm, see Figure 8.2.
Output capacitance	typ.	8 000μF	Included inside the power supply
Back-feeding loads	max.	35V	The unit is resistant and does not show malfunctioning when a load feeds back voltage to the power supply. It does not matter whether the power supply is on or off. The absorbing energy can be calculated according to the built-in large sized output capacitor.

¹ This current is also available for temperatures up to +70°C with a duty cycle of 10% and/or not longer than 1 minute every 10 minutes.

² The fuse braking current is an enhanced transient current which helps to start heavy loads or to trip fuses on faulty output branches. The output voltage stays above 20V. See chapter 26.1 for additional measurements.

³ At heavy overloads (when output voltage falls below 13V), the power supply delivers continuous output current for 2s. After this, the output is switched off for approx. 18s before a new start attempt is automatically performed. This cycle is repeated as long as the overload exists. If the overload has been cleared, the device will operate normally. See Figure 8.2.

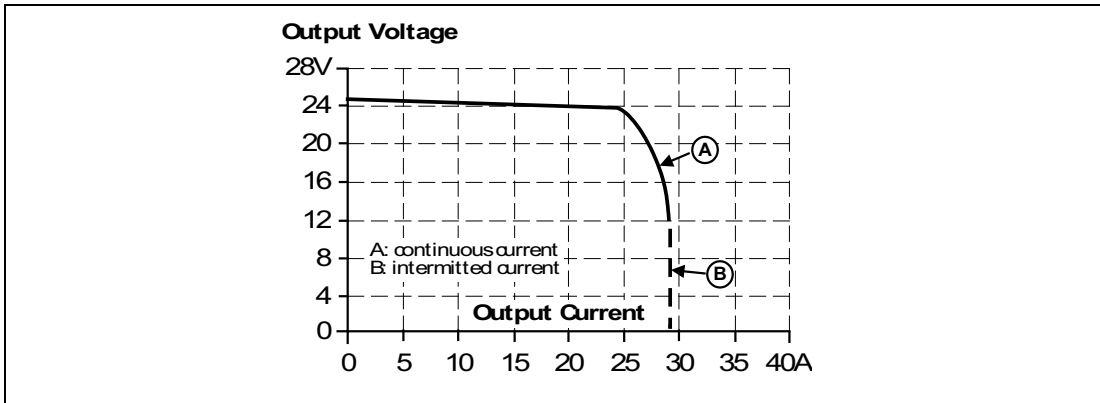

Figure 8.1 Output voltage vs. output current, typ.

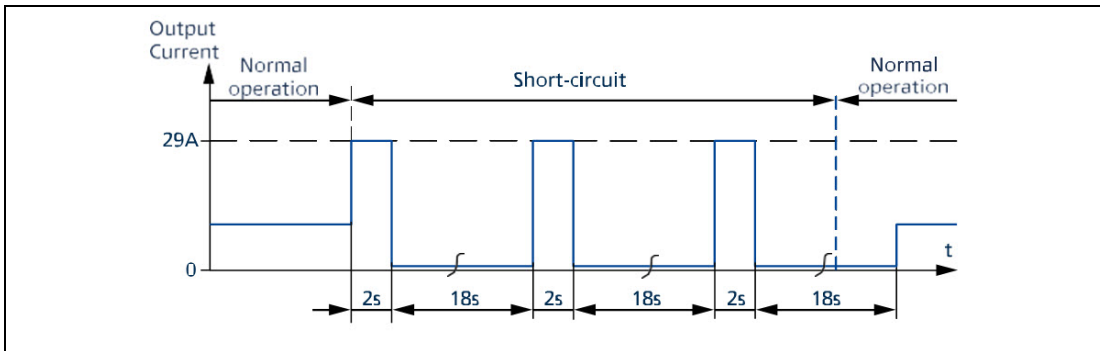

Figure 8.2 Short-circuit on output, **Hiccup** mode, typ.

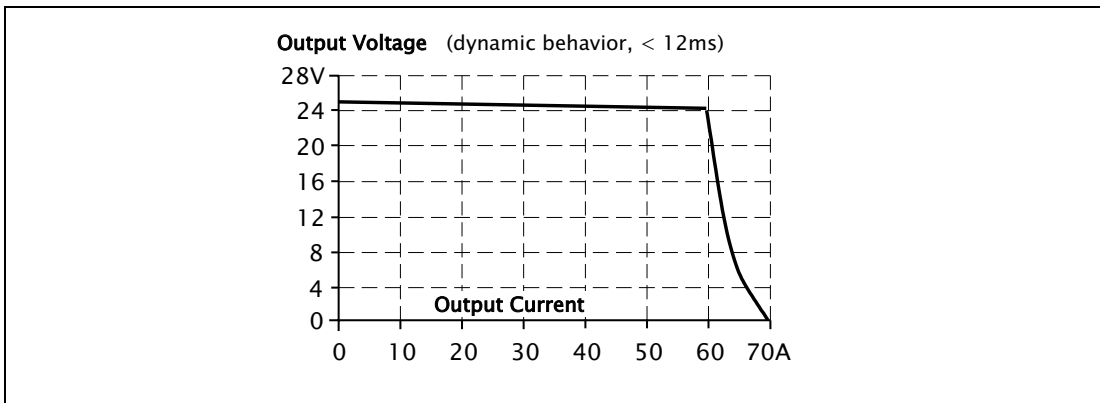

Figure 8.3 Dynamic overcurrent capability, typ.

9 Hold-Up Time

		AC 100V	AC 120V	AC 230V	
Hold-up Time	Typ.	65ms	65ms	65ms	At 10A, see Figure 9.1
	Min.	54ms	54ms	54ms	At 10A, see Figure 9.1
	Typ.	32ms	32ms	32ms	At 20A, see Figure 9.1
	Min.	24ms	24ms	24ms	At 20A, see Figure 9.1

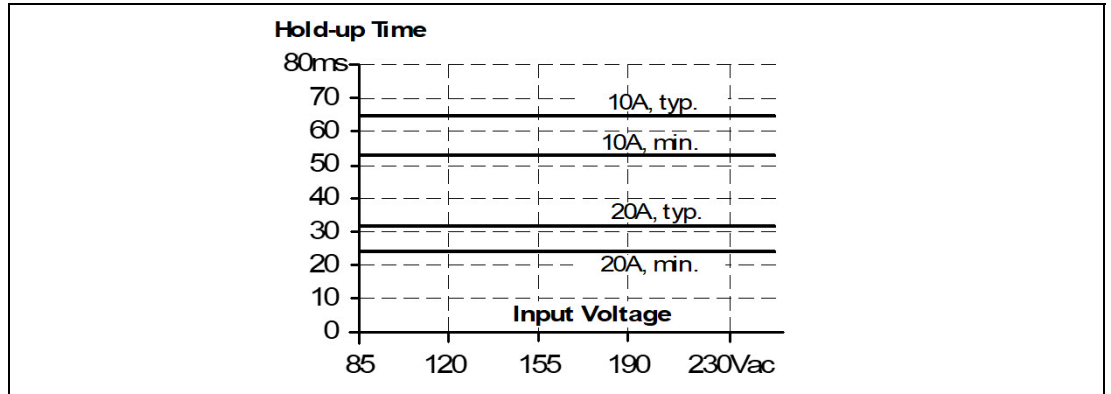

Figure 9.1 Hold-up time vs. input voltage

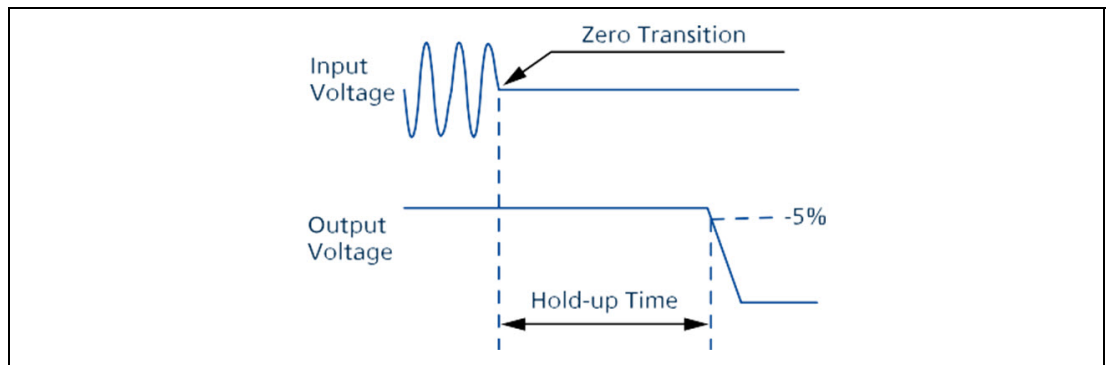

Figure 9.2 Shut-down behavior, definitions

10 DC-OK Relay Contact

This feature monitors the output voltage of the power supply in front of the decoupling device (see also chapter 14.)

Contact closes	As soon as the output voltage reaches typ. 22Vdc.
Contact opens	As soon as the output voltage dips below 22Vdc. Short dips will be extended to a signal length of 100ms. Dips shorter than 1ms will be ignored.
Switching hysteresis	1V
Contact ratings	Maximal 60Vdc 0.3A, 30Vdc 1A, 30Vac 0.5A, resistive load Minimal permissible load: 1mA at 5Vdc
Isolation voltage	See dielectric strength table in chapter 21.

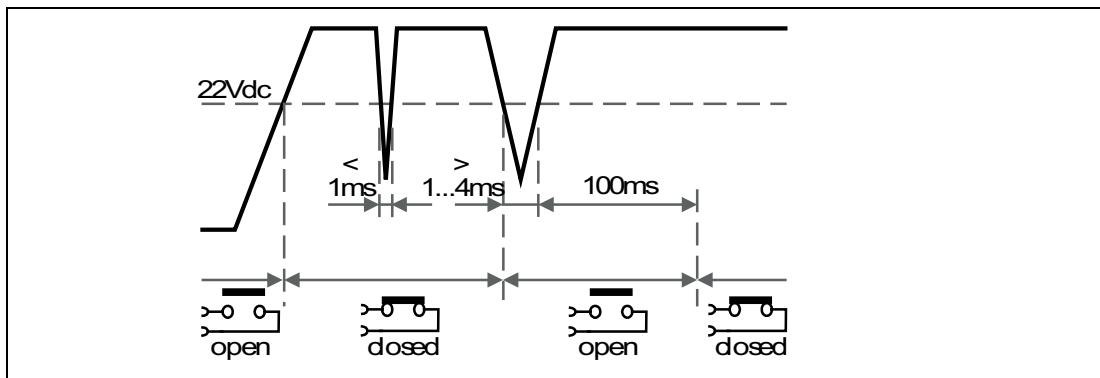

Figure 10.1 DC-OK relay contact behavior

11 Efficiency and Power Losses

		AC 100V	AC 120V	AC 230V	
Efficiency	Typ.	93.2%	93.8%	95.2%	At 20A
	Typ.	93.1%	93.7%	95.1%	At 24A (Power Boost)
Average efficiency ¹	Typ.	92.8%	93.4%	94.6%	25% at 5A, 25% at 10A, 25% at 15A. 25% at 20A
Power losses	Typ.	3.9W	3.5W	3.3W	At 0A
	Typ.	17.4W	16.4W	13.8W	At 10A
	Typ.	35.0W	31.7W	24.2W	At 20A
	Typ.	42.7W	38.7W	29.7W	At 24A (Power Boost)

¹ The average efficiency is an assumption for a typical application where the power supply is loaded with 25% of the nominal load for 25% of the time, 50% of the nominal load for another 25% of the time, 75% of the nominal load for another 25% of the time and with 100% of the nominal load for the rest of the time.

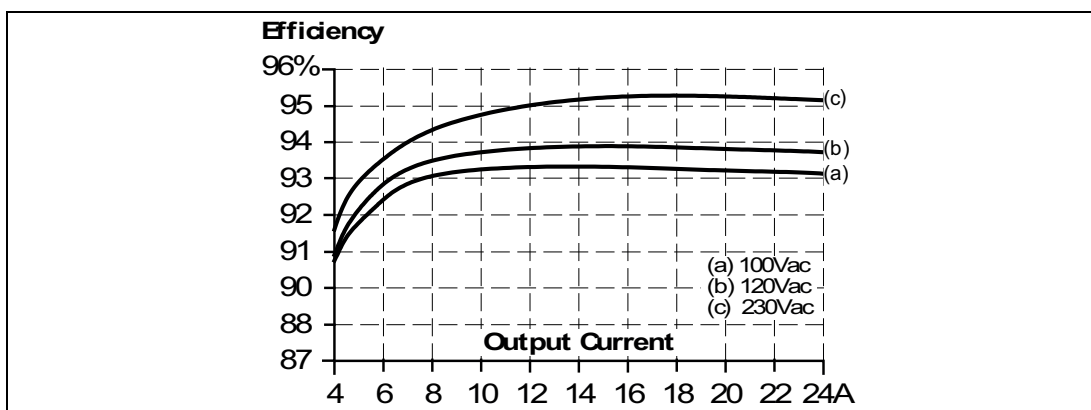

Figure 11.1 Efficiency vs. output current, typ.

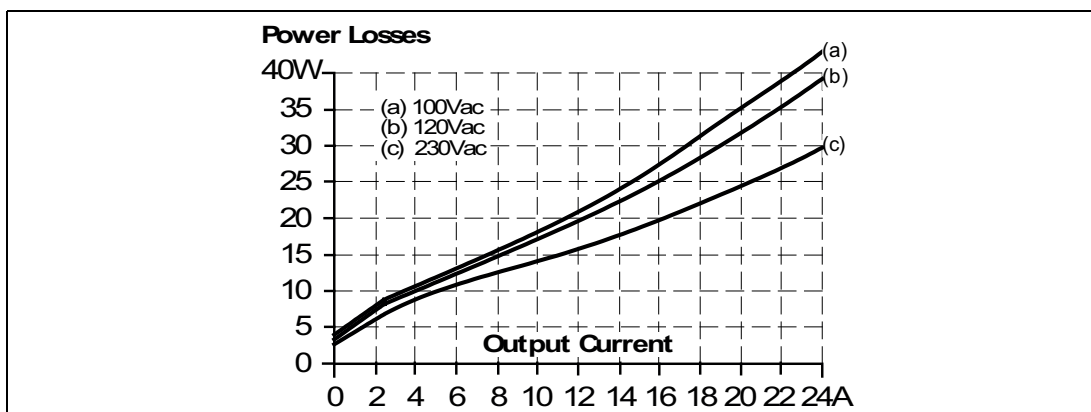

Figure 11.2 Losses vs. output current, typ.

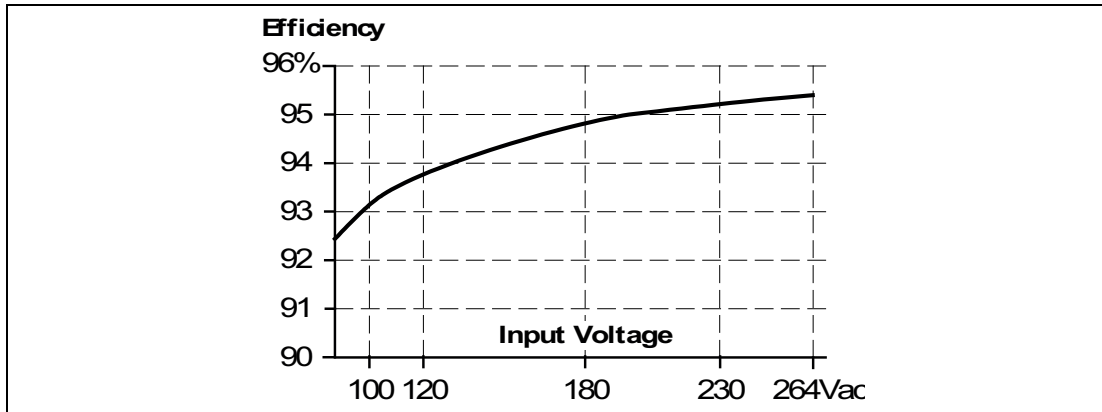

Figure 11.3 Efficiency vs. input voltage at 20A, typ.

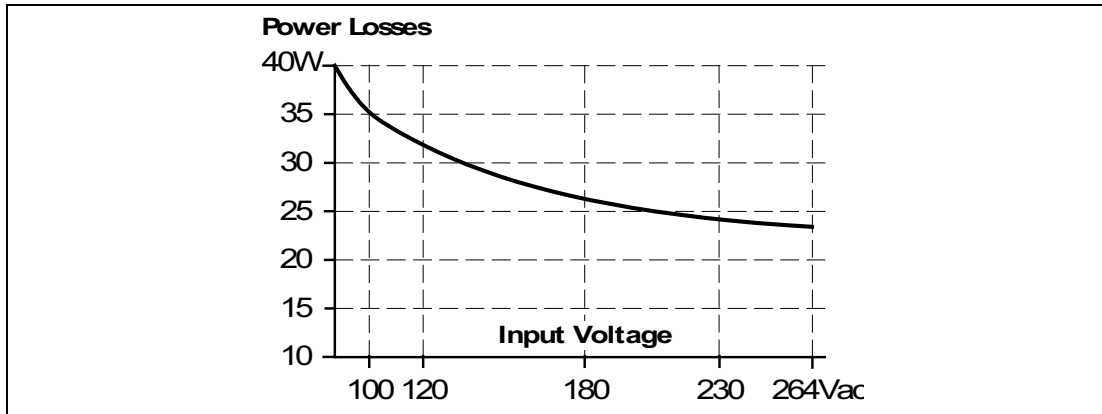

Figure 11.4 Losses vs. input voltage at 20A, typ.

12 Lifetime Expectancy

The Lifetime expectancy shown in the table indicates the minimum operating hours (service life) and is determined by the lifetime expectancy of the built-in electrolytic capacitors. Lifetime expectancy is specified in operational hours and is calculated according to the capacitor's manufacturer specification. The manufacturer of the electrolytic capacitors only guarantees a maximum life of up to 15 years (131 400h). Any number exceeding this value is a calculated theoretical lifetime which can be used to compare devices.

	AC 100V	AC 120V	AC 230V	
Lifetime expectancy	117 000h	136 000h	164 000h	At 10A and 40°C
	331 000h	386 000h	465 000h	At 10A and 25°C
	40 000h	53 000h	90 000h	At 20A and 40°C
	114 000h	150 000h	253 000h	At 20A and 25°C
	16 000h	25 000h	47 000h	At 24A and 40°C
	44 000h	69 000h	134 000h	At 24A and 25°C

13 MTBF

MTBF stands for **Mean Time Between Failure**, which is calculated according to statistical device failures, and indicates reliability of a device. It is the statistical representation of the likelihood of a unit to fail and does not necessarily represent the life of a product.

The MTBF figure is a statistical representation of the likelihood of a device to fail.

A MTBF figure of e.g. 1 000 000h means that statistically one unit will fail every 100 hours if 10 000 units are installed in the field. However, it cannot be determined if the failed unit has been running for 50 000h or only for 100h.

For these types of units the MTTF (**Mean Time To Failure**) value is the same value as the MTBF value.

	AC 100V	AC 120V	AC 230V	
MTBF SN 29500, IEC 61709	387 000h	412 000h	543 000h	At 20A and 40°C
	723 000h	768 000h	976 000h	At 20A and 25°C
MTBF MIL HDBK 217F	164 000h	169 000h	199 000h	At 20A and 40°C; Ground Benign GB40
	224 000h	231 000h	272 000h	At 20A and 25°C; Ground Benign GB25
	34 000h	36 000h	42 000h	At 20A and 40°C; Ground Fixed GF40
	45 000h	47 000h	56 000h	At 20A and 25°C; Ground Fixed GF25

14 Functional Diagram

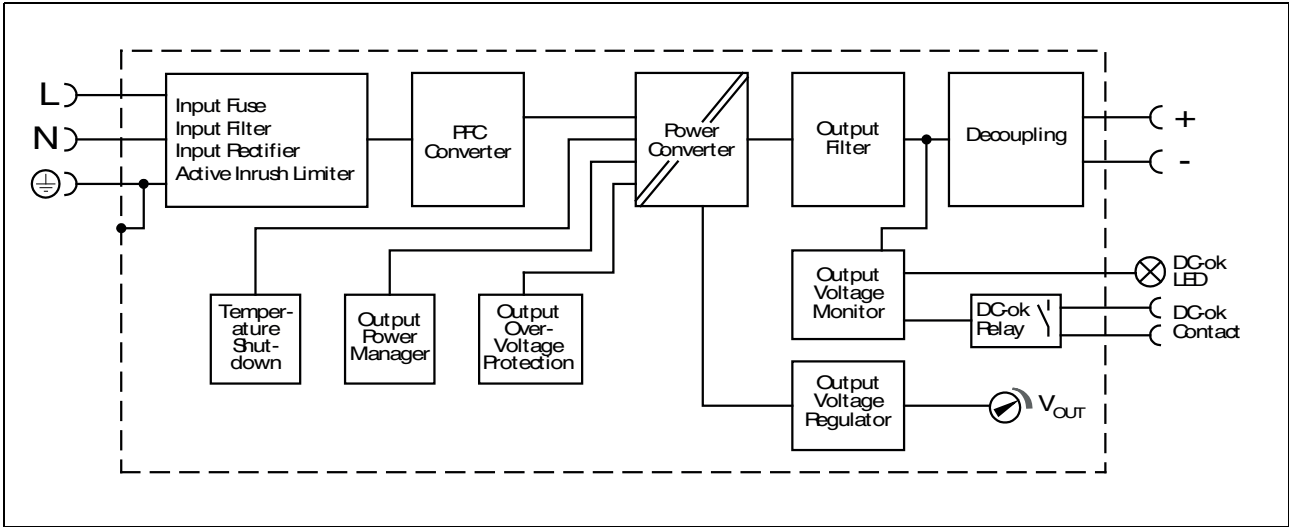

Figure 14.1 Functional diagram

15 Terminals and Wiring

The terminals are IP20 finger safe constructed and suitable for field- and factory wiring.

	Input	Output	DC-OK-Signal
Type	Plug connector with screw termination	Plug connector with screw termination	Plug connector with screw termination
Solid wire	Max. 4mm ²	Max. 6mm ²	Max. 1.5mm ²
Stranded wire	Max. 2.5mm ²	Max. 6mm ²	Max. 1.5mm ²
American Wire Gauge	AWG 20-12	AWG 24-10	AWG 26-14
Max. wire diameter (including ferrules)	2.4mm	3.2mm	1.8mm
Recommended tightening torque	Max. 0.5Nm, 4.5lb-in	Max. 0.6Nm, 5.3lb-in	Max. 0.8Nm, 7lb-in
Wire stripping length	7mm / 0.28inch	12mm / 0.47inch	6mm / 0.24inch
Screwdriver	3.5mm slotted or cross-head No 2	3.5mm slotted or cross-head No 2	3mm slotted
	Do not unplug the connectors more often than 20 times in total	Do not unplug the connectors more often than 20 times in total	Do not unplug the connectors more often than 20 times in total



Connecting Terminals

1. Use appropriate copper cables that are designed for minimum operating temperatures of:
 - 60°C for ambient up to 45°C and
 - 75°C for ambient up to 60°C minimum
 - 90°C for ambient up to 70°C minimum.
2. Follow national installation codes and installation regulations!
3. Ensure that all strands of a stranded wire enter the terminal connection!
4. Unused terminal compartments should be securely tightened.
5. Ferrules are allowed and recommended.

16 Replacing Units while the System is Running

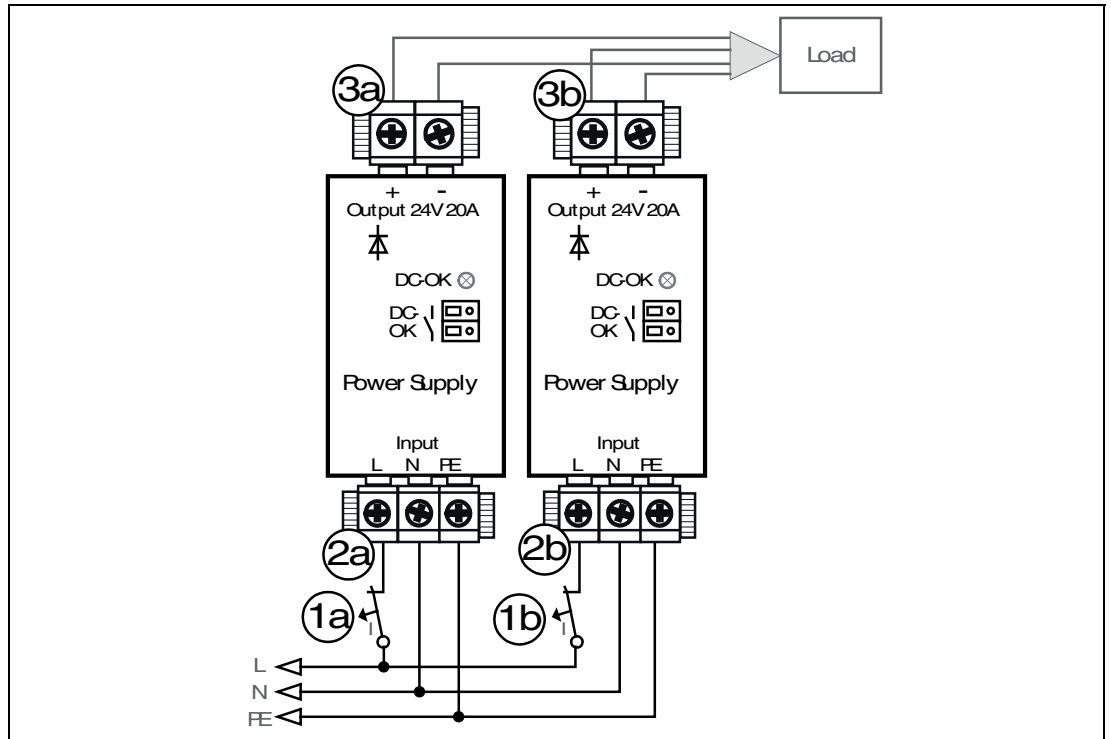

Figure 16.1 Replacing the power supply or redundancy module while the system is running



Replacing the Units

1. Switch-off circuit breaker (1a).
2. Remove plug (2a).
3. Remove plug (3a). The plug prevents the cables from shorting.
4. Change power supply.
5. Put the plug (3a) back in.
6. Put the plug (2a) back in.
7. Turn-on the circuit breaker (1a).
8. The circuit is redundant again.
9. To replace the right power supply, repeat the process above using (1b), (2b) and (3b).

17 Front Side and User Elements

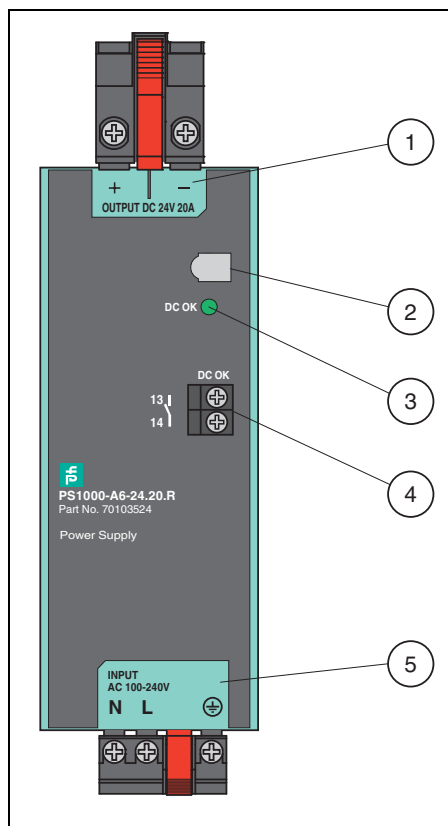

1 Output Terminals

- + Positive output
- Negative (return) output

2 Output Voltage Potentiometer

see chapter 26.2

3 DC-OK LED (green)

On, when the output voltage is above 22V.

4 DC-OK Relay Contact

The DC-OK relay contact is synchronized with the DC-OK LED. See chapter 10 for details.

5 Input Terminals

- N, L Line input
- ⊕ PE (Protective Earth) input

Figure 17.1 Front side

18 EMC

The EMC behavior of the device is designed for applications in industrial environment as well as in residential, commercial and light industry environments.

EMC Immunity	According to generic standards: EN 61000-6-1, and EN 61000-6-2.			
Electrostatic discharge	EN 61000-4-2	Contact discharge	8kV	Criterion A
		Air discharge	15kV	Criterion A
Electromagnetic RF field	EN 61000-4-3	80MHz-2.7GHz	20V/m	Criterion A
Fast transients (Burst)	EN 61000-4-4	Input lines	4kV	Criterion A
		Output lines	2kV	Criterion A
		DC-OK signal (coupling clamp)	2kV	Criterion A
Surge voltage on input	EN 61000-4-5	L → N	2kV	Criterion A
		L → PE, N → PE	4kV	Criterion A
Surge voltage on output	EN 61000-4-5	+ → -	1kV	Criterion A
		+ / - → PE	2kV	Criterion A
Surge voltage on signals	EN 61000-4-5	DC-OK signal → PE	1kV	Criterion A
Conducted disturbance	EN 61000-4-6	0.15-80MHz	20V	Criterion A
Mains voltage dips	EN 61000-4-11	0% of 100Vac	0Vac, 20ms	Criterion A
		40% of 100Vac	40Vac, 200ms	Criterion C
		70% of 100Vac	70Vac, 500ms	Criterion C
		0% of 200Vac	0Vac, 20ms	Criterion A
		40% of 200Vac	80Vac, 200ms	Criterion A
		70% of 200Vac	140Vac, 500ms	Criterion A
Voltage interruptions	EN 61000-4-11	0% of 200Vac (=0V)	5000ms	Criterion C
Voltage sags	SEMI F47 0706	80% of 120Vac (96Vac)	1000ms	Criterion A
		70% of 120Vac (84Vac)	500ms	Criterion A
		50% of 120Vac (60Vac)	200ms	Criterion A
Powerful transients	VDE 0160	Over entire load range	750V, 0.3ms	Criterion A

Criterion A The device shows normal operation behavior within the defined limits.

Criterion C Temporary loss of function is possible. The device may shut-down and restarts by itself. No damage or hazards for the power supply will occur.

EMC Emission	According to the generic standards EN 61000-6-3 and EN 61000-6-4.	
Conducted emission input lines	EN 55011, EN 55015, EN 55022, FCC Part 15, CISPR 11, CISPR 22	Class B
Conducted emission output lines	IEC/CISPR 16-1-2, IEC/CISPR 16-2-1	5dB higher than average limits for DC power port according EN 61000-6-3 ¹
Radiated emission	EN 55011, EN 55022	Class B
Harmonic input current (PFC)	EN 61000-3-2	Class A equipment: fulfilled Class C equipment: fulfilled in the load range from 8 to 24A
Voltage fluctuations, flicker	EN 61000-3-3	Fulfilled, tested with constant current loads, non pulsing

This device complies with FCC Part 15 rules.

Operation is subjected to following two conditions: (1) this device may not cause harmful interference, and (2) this device must accept any interference received, including interference that may cause undesired operation.

¹ Restrictions apply for applications in residential, commercial and light-industrial environments, where local DC power networks according to EN 61000-6-3 are involved. No restrictions for all kinds of industrial applications.

Switching Frequencies

PFC converter	100kHz	Fixed frequency
Main converter	80kHz to 140kHz	Output load dependent
Auxiliary converter	60kHz	Fixed frequency

19 Environment

Operational temperature	-40°C to +70°C (-40°F to 158°F)	Operational temperature is the same as the ambient or surrounding temperature and is defined as the air temperature 2cm below the unit.
Storage temperature	-40°C to +85°C (-40°F to 185°F)	For storage and transportation
Output derating	0.27A/°C 0.5A/°C 1.25A/1000m or 5°C/1000m 0.75A/-5kPa or 3°C/-5kPa	Between +45°C and +60°C (113°F to 140°F) Between +60°C and +70°C (140°F to 158°F) For altitudes >2000m (6560ft), see Figure 19.2 For atmospheric pressures <80kPa, see Figure 19.2 The derating is not hardware controlled. The customer has to take this into consideration to stay below the derated current limits in order not to overload the unit.
Humidity	5 to 95% r.h.	According to IEC 60068-2-30 Do not energize while condensation is present.
Atmospheric pressure	110-47kPa	See Figure 19.2 for details
Altitude	Up to 6000m (20000ft)	See Figure 19.2 for details
Over-voltage category	III II	According to IEC 60664-1 for altitudes <2000m According to IEC 60664-1 for altitudes between 2000 and 6000m and atmospheric pressures from 80-47kPa.
Degree of pollution	2	According to IEC 62477-1, not conductive
Vibration sinusoidal	2-17.8Hz: ±1.6mm 17.8-500Hz: 2g 2 hours / axis	According to IEC 60068-2-6
Shock	30g 6ms, 20g 11ms 3 bumps / direction, 18 bumps in total	According to IEC 60068-2-27 Shock and vibration is tested in combination with DIN-Rails according to EN 60715 with a height of 15mm and a thickness of 1.3mm and standard orientation.
LABS compatibility	As a rule, only non-silicon precipitating materials are used. The unit conforms to the LABS criteria and is suitable for use in paint shops.	
Corrosive gases	Tested according to ISA-71.04-1985, Severity Level G3 and IEC 60068-2-60 Test Ke Method 4 for a service life of minimum 10years in these environments.	
Audible noise	Some audible noise may be emitted from the power supply during no load, overload or short circuit.	

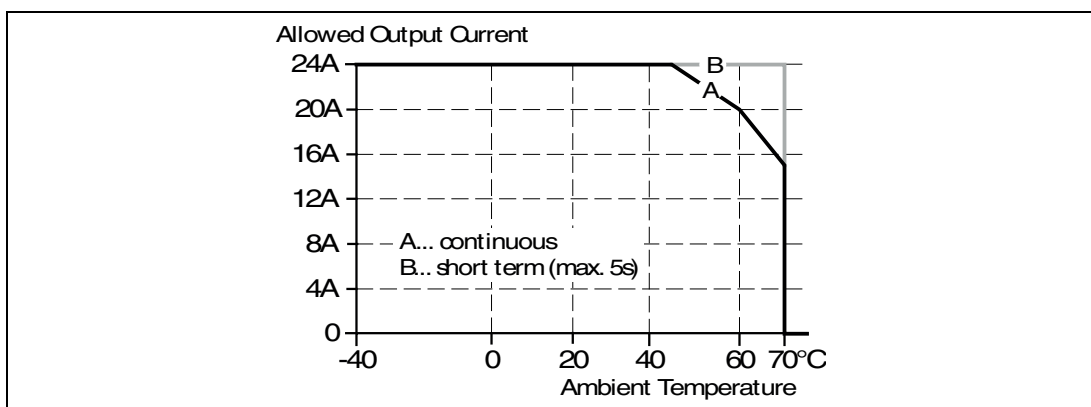

Figure 19.1 Output current vs. ambient temp.

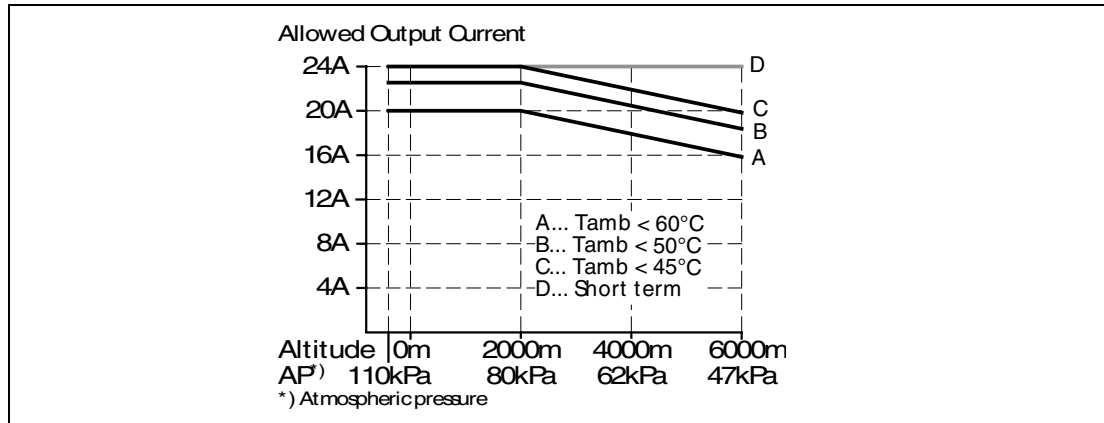

Figure 19.2 Output current vs. altitude

20 Safety and Protection Features

Isolation resistance	Min. 500M Ω	At delivered condition between input and output, measured with 500Vdc
	Min. 500M Ω	At delivered condition between input and PE, measured with 500Vdc
	Min. 500M Ω	At delivered condition between output and PE, measured with 500Vdc
	Min. 500M Ω	At delivered condition between output and DC-OK contacts, measured with 500Vdc
PE resistance	Max. 0.1 Ω	Resistance between PE terminal and the housing in the area of the DIN-rail mounting bracket.
Output over-voltage protection	Typ. 30.5Vdc Max. 32Vdc	In case of an internal defect, a redundant circuit limits the maximum output voltage. The output shuts down and automatically attempts to restart.
Class of protection	I	According to IEC 61140 A PE (Protective Earth) connection is required
Degree of protection	IP20	According to EN/IEC 60529
Over-temperature protection	Included	Output shut-down with automatic restart. Temperature sensors are installed on critical components inside the unit and turn the unit off in safety critical situations, which can happen e.g. when ambient temperature is too high, ventilation is obstructed or the de-rating requirements are not followed. There is no correlation between the operating temperature and turn-off temperature since this is dependent on input voltage, load and installation methods.
Input transient protection	MOV (Metal Oxide Varistor)	For protection values, see chapter 18 (EMC).
Internal input fuse	Included	Not user replaceable slow-blow high-breaking capacity fuse
Touch current (leakage current)	Typ. 0.12mA / 0.31mA	At 100Vac, 50Hz, TN-,TT-mains / IT-mains
	Typ. 0.18mA / 0.45mA	At 120Vac, 60Hz, TN-,TT-mains / IT-mains
	Typ. 0.30mA / 0.76mA	At 230Vac, 50Hz, TN-,TT-mains / IT-mains
	Max. 0.16mA / 0.38mA	At 110Vac, 50Hz, TN-,TT-mains / IT-mains
	Max. 0.23mA / 0.55mA	At 132Vac, 60Hz, TN-,TT-mains / IT-mains
	Max. 0.39mA / 0.94mA	At 264Vac, 50Hz, TN-,TT-mains / IT-mains

21 Dielectric Strength

The output voltage is floating and has no ohmic connection to the ground. Type and routine tests are conducted by the manufacturer. Field tests may be conducted in the field using the appropriate test equipment which applies the voltage with a slow ramp (2s up and 2s down). Connect all input-terminals together as well as all output poles before conducting the test. When testing, set the cut-off current settings to the value in the table below.

It is recommend that either the + pole, the – pole or any other part of the output circuit shall be connected to the earth/ground system. This helps to avoid situations in which a load starts unexpectedly or can not be switched off when unnoticed earth faults occur.

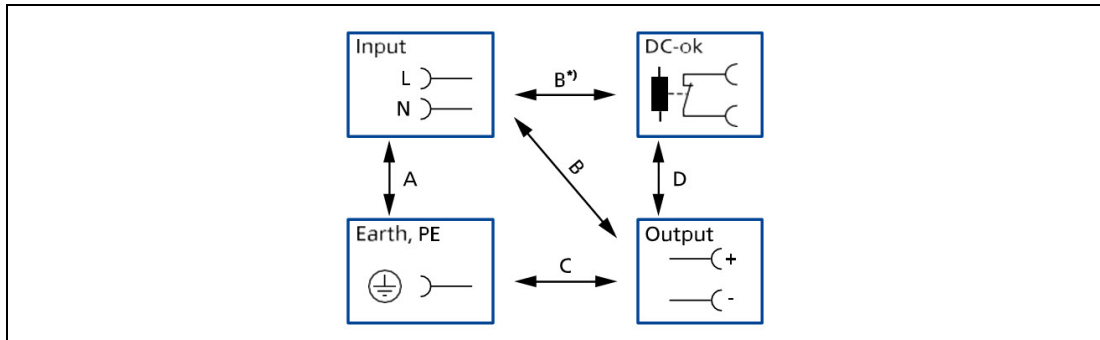

Figure 21.1 Dielectric strength

B*) When testing input to DC-OK ensure that the maximal voltage between DC-OK and the output is not exceeded (column D). We recommend connecting DC-OK pins and the output pins together when performing the test.

		A	B	C	D
Type test	60s	2 500Vac	3 000Vac	1 000Vac	500Vac
Routine test	5s	2 500Vac	2 500Vac	500Vac	500Vac
Field test	5s	2 000Vac	2 000Vac	500Vac	500Vac
Cut-off current setting for field test		> 10mA	> 10mA	> 20mA	> 1mA

22 Approvals

EU Declaration of Conformity



The CE mark indicates conformance with the European

- ATEX directive
- EMC directive
- Low-voltage directive (LVD)
- RoHS directive

UL 61010



UL Certificate

Listed equipment for category NMTR - UL 61010-2-201
Electrical Equipment for Measurement, Control and
Laboratory Use - Particular requirements for control
equipment

Applicable for US and Canada

E-Files: E350173 , E223176

EN 60079-0:2012+A11:2013,
EN 60079-7:2015+A1:2018,
EN 60079-15:2010



ATEX certificate: EPS 17 ATEX 1089 X

ATEX marking: Ⓜ II 3G Ex ec nC II T4 Gc

IEC 60079-0:2011,
IEC 60079-7:2015,
IEC 60079-15:2010



IECEx certificate: IECEx EPS 20.0056X

IECEx marking: Ex ec nC IIC T4 Gc

EAC TR Registration



EAC Certificate

EAC EurAsian Conformity Registration Russia,
Kazakhstan and Belarus

23 Other Fulfilled Standards

RoHS Directive	RoHS ✓	Directive 2011/65/EU of the European Parliament and the Council of June 8th, 2011 on the restriction of the use of certain hazardous substances in electrical and electronic equipment.
REACH Directive	REACH ✓	Directive 1907/2006/EU of the European Parliament and the Council of June 1st, 2007 regarding the R egistration, E valuation, A uthorisation and R estriction of C hemicals (REACH)
IEC/EN 61558-2-16 (Annex BB)	Safety Isolating Transformer	Safety Isolating Transformers corresponding to Part 2-6 of the IEC/EN 61558

24 Physical Dimensions and Weight

Width	48mm, 1.89 inch
Height	124mm, 4.88 inch (without plug-connectors)
Depth	127mm, 5 inch (without plug-connector) The DIN mounting rail height must be added to the unit depth to calculate the total required installation depth.
Weight	850g/1.87lb
DIN mounting rail	Use 35mm DIN mounting rails according to EN 60715 or EN 50022 with a height of 7.5 or 15mm.
Housing material	Body: Aluminium alloy Cover: zinc-plated steel
Installation instructions	See chapter 4.
Penetration protection	Small parts like screws, nuts, etc. with a diameter larger than 5mm.

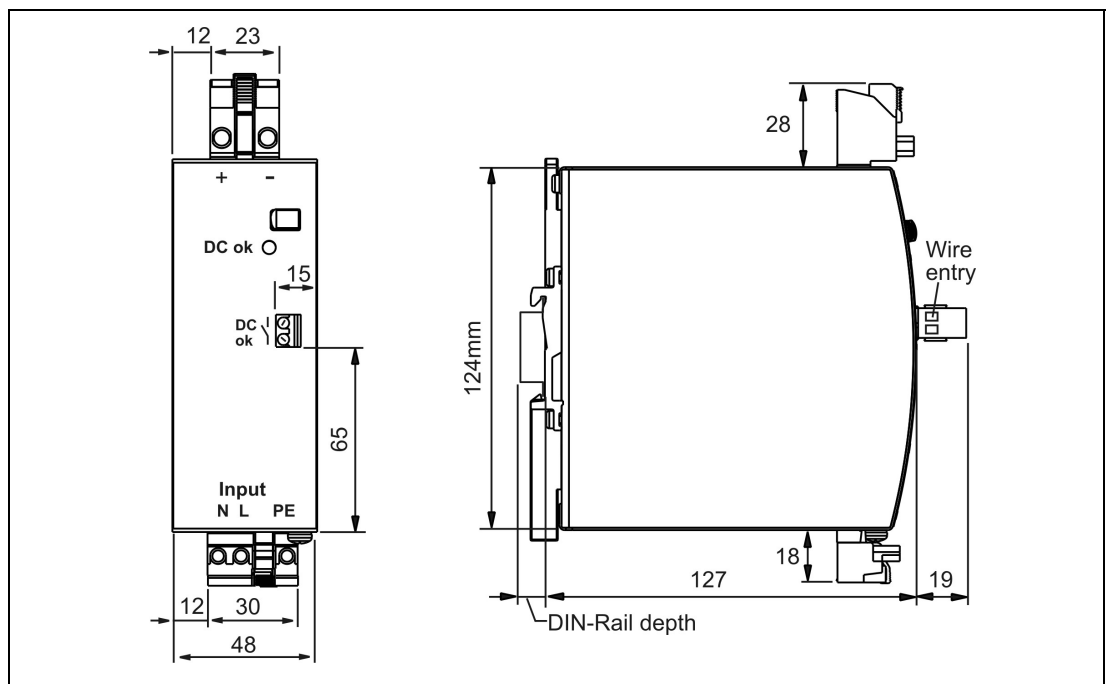

Figure 24.1 Device dimensions, all dimensions in mm

25 Application Notes

25.1 Peak Current Capability

The unit can deliver peak currents (up to several milliseconds) which are higher than the specified short term currents.

This helps to start current demanding loads. Solenoids, contactors and pneumatic modules often have a steady state coil and a pick-up coil. The inrush current demand of the pick-up coil is several times higher than the steady-state current and usually exceeds the nominal output current (including the PowerBoost). The same situation applies when starting a capacitive load.

The peak current capability also ensures the safe operation of subsequent circuit breakers of load circuits. The load branches are often individually protected with circuit breakers or fuses. In case of a short or an overload in one branch circuit, the fuse or circuit breaker need a certain amount of over-current to open in a timely manner. This avoids voltage loss in adjacent circuits.

The extra current (peak current) is supplied by the power converter and the built-in large sized output capacitors of the device. The capacitors get discharged during such an event, which causes a voltage dip on the output. The following three examples show typical voltage dips for resistive loads:

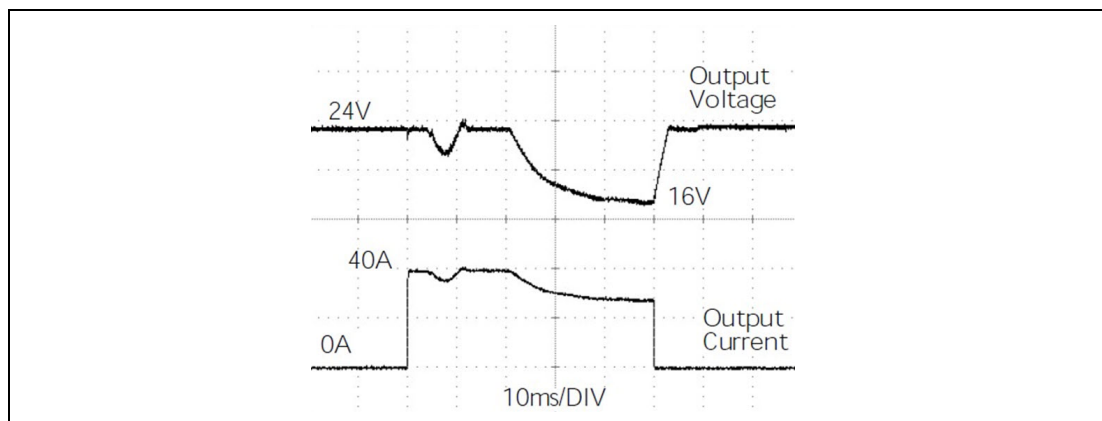

Figure 25.1 40A peak current for 50ms , typ. (2x the nominal current)

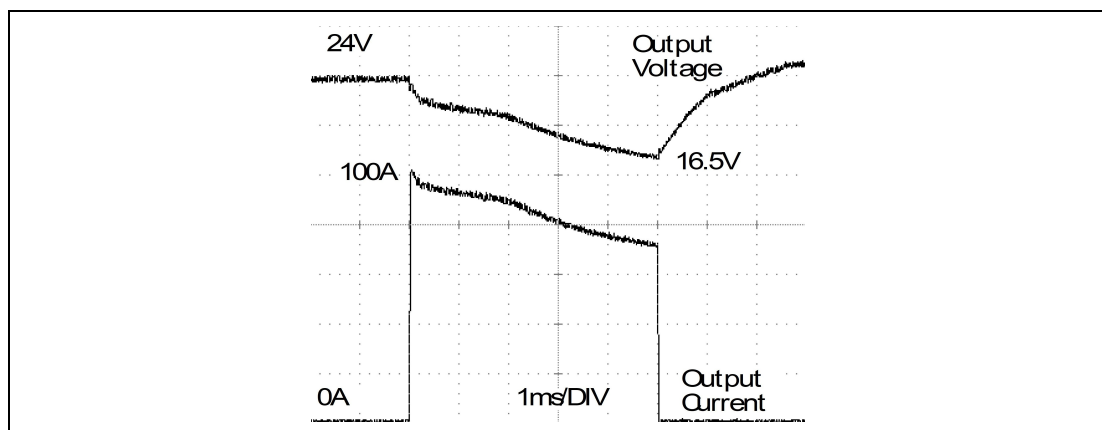

Figure 25.2 100A peak current for 5ms , typ. (5x the nominal current)

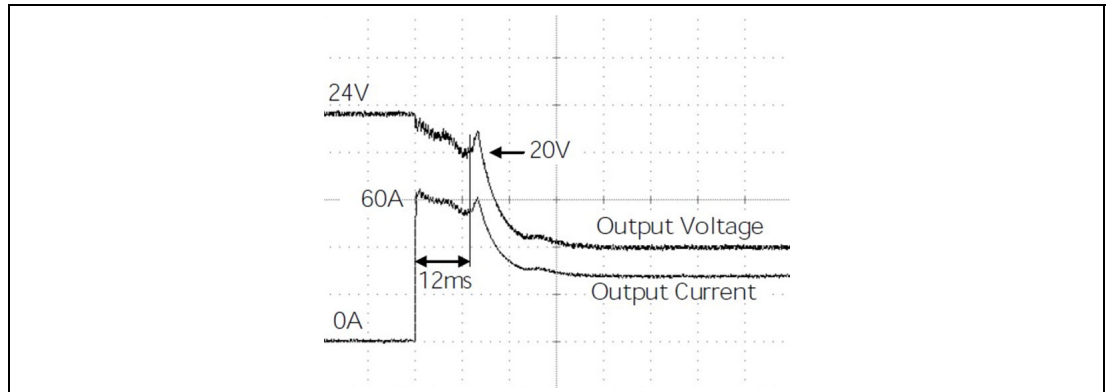

Figure 25.3 60A peak current for 12ms , typ. (3x the nominal current)



Note

The DC-OK relay triggers when the voltage dips below 22Vdc for longer than 1ms.

Peak current voltage dips	Typically from 24V to 16 at 40A for 50ms, resistive load Typically from 24V to 21V at 100A for 2ms, resistive load Typically from 24V to 16.5V at 100A for 5ms, resistive load
---------------------------	--

25.2 Adjusting the Output Voltage

A voltage adjustment potentiometer can be found behind the flap on the front of the unit. However, it is not recommended to change the output voltage since load sharing between devices connected in parallel can only be achieved by a precise setting of the output voltages. The factory settings allow precise load sharing and only qualified personnel should change the adjustment potentiometer.

Lower end of the specified adjustment range

Output voltage	nom.	24.0V	Due to the soft output voltage regulation characteristic (parallel mode feature) a setting to 24.0V results to an output voltage of $23.8V \pm 0.2\%$ at 24A and $25.0V \pm 0.2\%$ at no load. See Figure 25.4.
Output current	min.	24A	At 45°C
	min.	20A	At 60°C
	min.	15A	At 70°C

Reduce output current linearly between +45°C and +70°C.

Upper end of the specified adjustment range

Output voltage	nom.	28.0V	Due to the soft output voltage regulation characteristic (parallel mode feature) a setting to 28.0V results to an output voltage of $27.7V \pm 0.2\%$ at 20.6A and $29.2V \pm 0.2\%$ at no load. See Figure 25.4.
Output current	min.	20.6A	At 45°C
	min.	17.1A	At 60°C
	min.	13.0A	At 70°C

Reduce output current linearly between +45°C and +70°C.

The maximum output voltage which can occur at the clockwise end position of the potentiometer due to tolerances is 30V. It is not a guaranteed value which can be achieved. The typical value is 29.5V.

Current values between 24 and 28V can be interpolated.

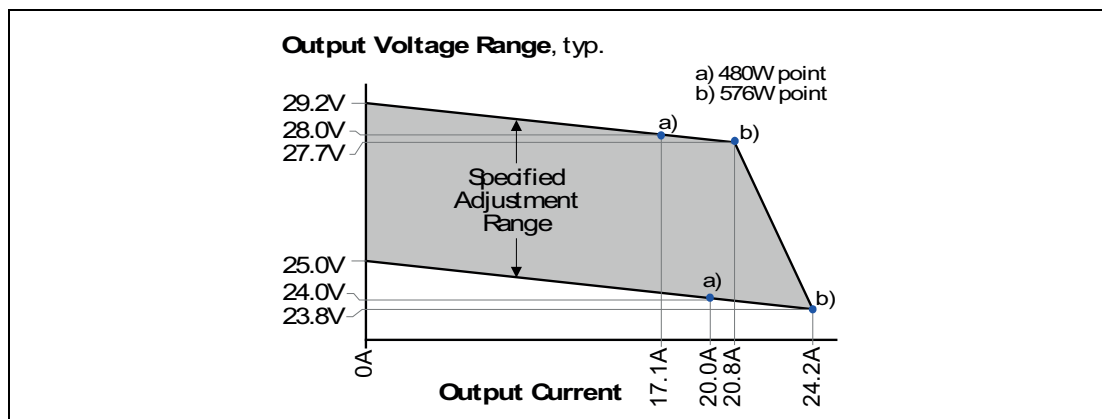

Figure 25.4 Adjustment range of the output voltage

The output voltage shall only be changed when absolutely necessary, e.g., for battery charging as described in the next chapter.

25.3 Charging of Batteries

This redundancy device is ideal for charging batteries due to the decoupling circuit built in to the output stage which does not require a fuse or diode between the device and the battery. Sealed lead acid (SLA) or valve regulated lead acid (VRLA) lead batteries can be charged.



Charging Batteries

1. Set output voltage (measured at disconnected battery) very precisely to the end-of-charge voltage, see table below. Use the potentiometer, which is hidden behind the flap on the front of the unit, see chapter 25.2.
2. Ensure that the ambient temperature of the device stays below +40°C.
3. Use only matched batteries when connecting 12V types in series.
4. The return current to the device (battery discharge current) is typ. 11mA when the device is switched off.

Battery temperature	10°C	20°C	30°C	40°C
End-of-charge voltage	27.8V	27.5V	27.15V	26.8V

25.4 Output Circuit Breakers

Standard miniature circuit breakers (MCBs or UL 1077 circuit breakers) are commonly used for AC-supply systems and may also be used on 24V branches.

MCBs are designed to protect wires and circuits. If the ampere value and the characteristics of the MCB are adapted to the wire size that is used, the wiring is considered as thermally safe regardless of whether the MCB opens or not.

To avoid voltage dips and under-voltage situations in adjacent 24V branches which are supplied by the same source, a fast (magnetic) tripping of the MCB is desired. A quick shutdown within 10ms is necessary corresponding roughly to the ride-through time of PLC's. This requires devices with high current reserves and large output capacitors. Furthermore, the impedance of the faulty branch must be sufficiently small in order for the current to actually flow. The best current reserve in the device does not help if Ohm's law does not permit current flow. The following table has typical test results showing which B- and C-Characteristic MCBs magnetically trip depending on the wire cross section and wire length.

Maximal wire length ¹ for a fast (magnetic) tripping:

	0.75mm ²	1.0mm ²	1.5mm ²	2.5mm ²
C-2A	34m	45m	64m	101m
C-3A	27m	36m	52m	79m
C-4A	19m	26m	35m	56m
C-6A	9m	12m	16m	23m
C-8A	4m	8m	12m	18m
C-10A	4m	6m	9m	15m
C-13A	2m	3m	4m	5m
B-6A	23m	30m	38m	67m
B-10A	11m	14m	21m	32m
B-13A	7m	12m	17m	23m
B-16A	4m	6m	8m	11m
B-20A	1m	1m	2m	4m

¹ Don't forget to consider twice the distance to the load (or cable length) when calculating the total wire length (+ and - wire).

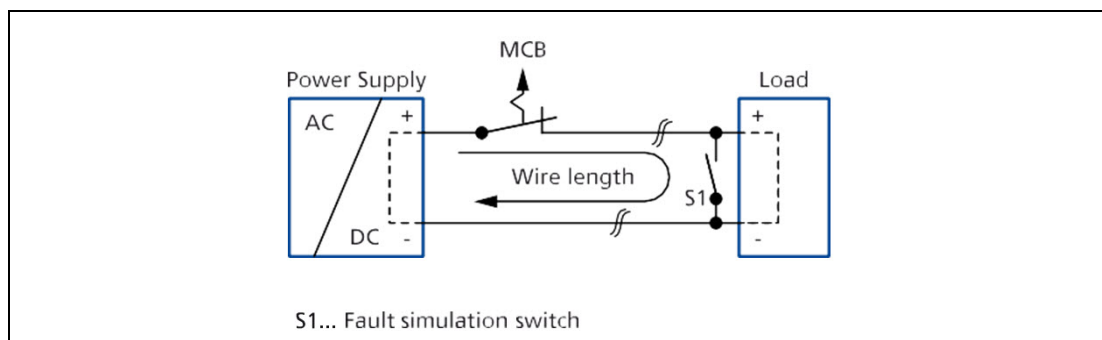

Figure 25.5 Test circuit

25.5 Series Operation

Devices of the same type can be connected in series for higher output voltages. It is possible to connect as many units in series as needed, providing the sum of the output voltage does not exceed 150Vdc. Voltages with a potential above 60Vdc must be installed with a protection against touching.

Avoid return voltage (e.g., from a decelerating motor or battery) which is applied to the output terminals.

Restrictions

- Keep an installation clearance of 15mm (left / right) between two devices and avoid installing the devices on top of each other.
- Do not use devices in series in mounting orientations other than the standard mounting orientation (input terminals on bottom of the unit).

Pay attention that leakage current, EMI, inrush current, harmonics will increase when using multiple devices.

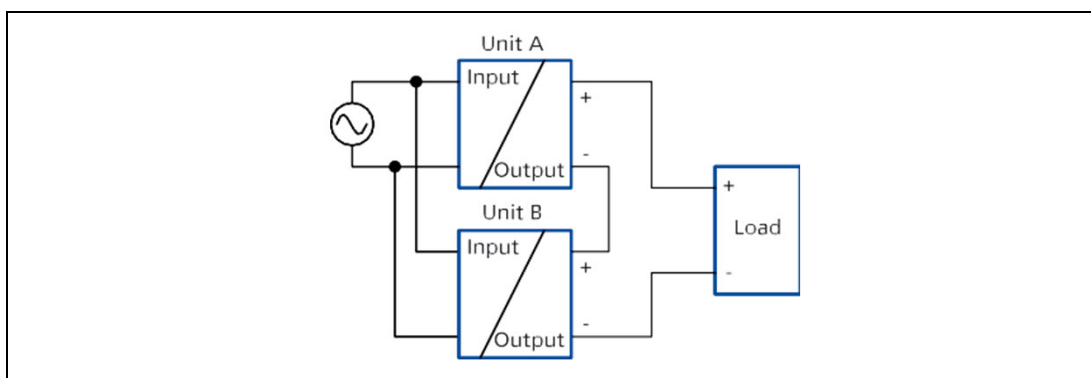

Figure 25.6 Series operation

25.6 Parallel Use to Increase Output Power

Devices can be paralleled to increase the output power. For redundancy applications one extra device is always needed for sufficient output current in case one unit fails.

The unit is permanently set to **Parallel use** mode in order to achieve load sharing between devices connected in parallel. The **Parallel use** mode regulates the output voltage in such a manner that the voltage at no load is approx. 4% higher than at nominal load.

See also chapter 8.

Energize all units at the same time. It also might be necessary to cycle the input power (turn-off for at least five seconds), if the output was in overload or short circuits and the required output current is higher than the current of one unit.

Restrictions

- Keep an installation clearance of 15mm (left / right) between two devices and avoid installing the devices on top of each other.
- Do not use devices in parallel in mounting orientations other than the standard mounting orientation (input terminals on bottom of the unit) or in any other condition where a derating of the output current is required (e.g. altitude).

Pay attention that leakage current, EMI, inrush current, harmonics will increase when using multiple devices.

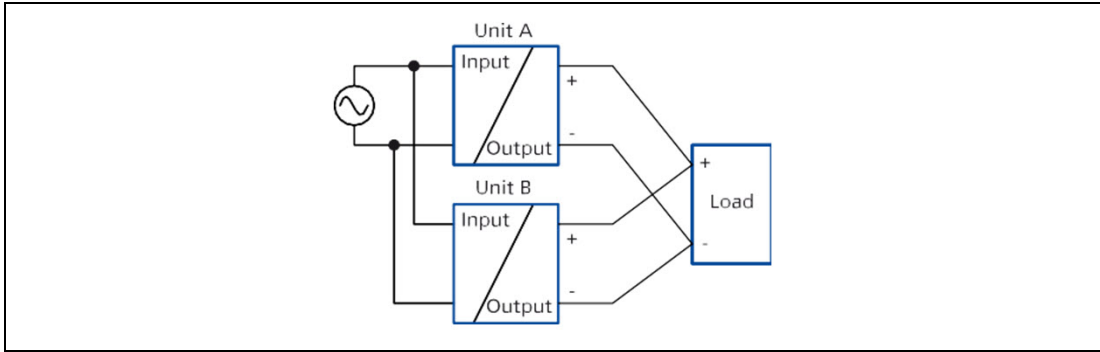

Figure 25.7 Parallel use to increase output power

Do not load paralleled devices with higher currents as shown in the following diagrams:

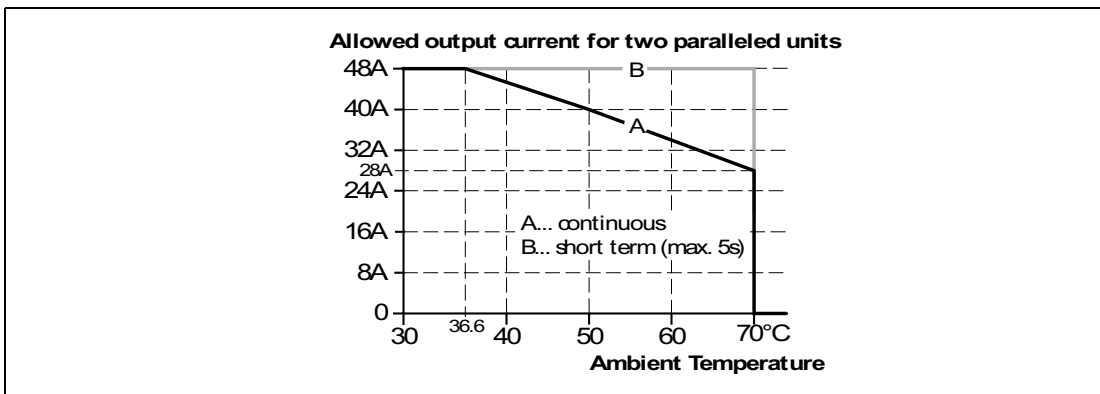

Figure 25.8 Output current vs. ambient temperature for two paralleled units

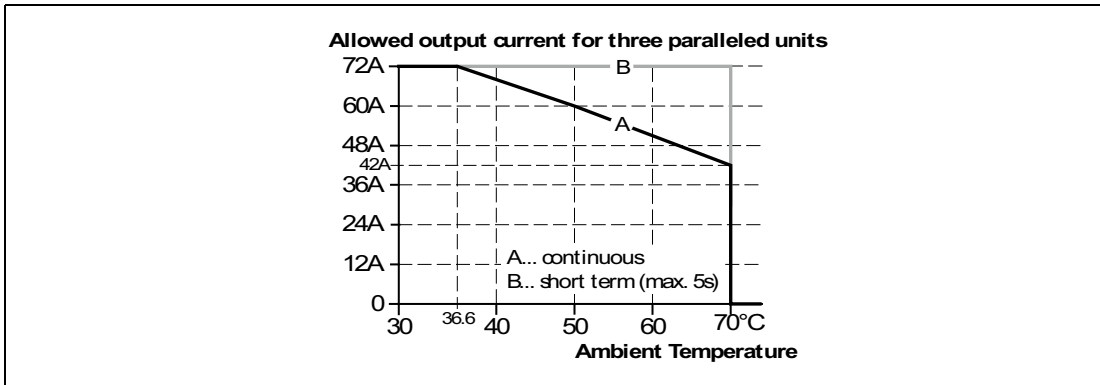

Figure 25.9 Output current vs. ambient temperature for three paralleled units

25.7 Parallel Use for Redundancy

Devices can be paralleled for redundancy to gain higher system availability. The unit is already equipped with a MOSFET as decoupling device on the output to avoid, that a faulty unit becomes a load for the other power supplies and the output voltage cannot be maintained any more.

Recommendations for building redundant power systems:

- Use separate input fuses for each power supply.
- Monitor the individual power supply units by utilizing the built-in DC-OK relay contacts on each power supply.

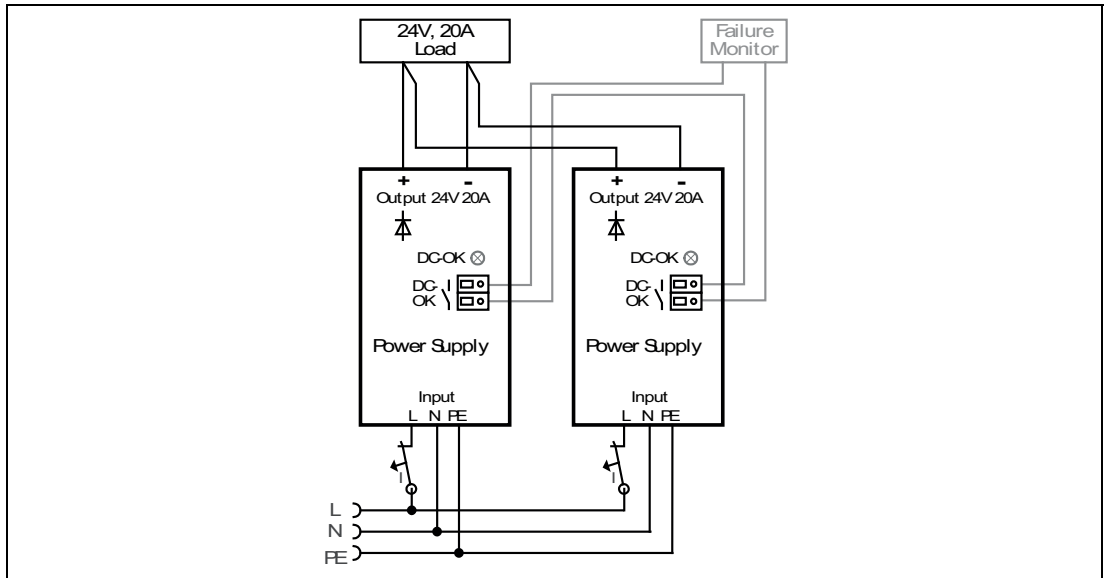

Figure 25.10 Wiring diagram, 1+1 Redundancy for 20A output current

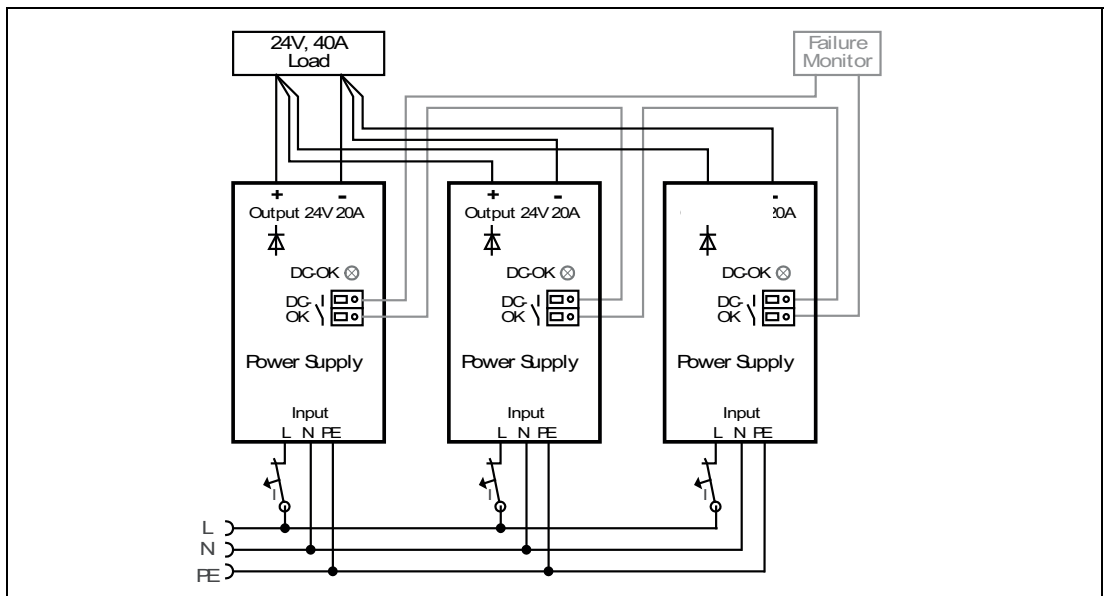

Figure 25.11 Wiring diagram, N+1 Redundancy for 40A output current



Note

- Observe the temperature derating requirements of Figure 25.8 and Figure 25.9 for N+1 redundancy applications.
- Use separate mains systems for each power supply whenever it is possible.

25.8 Two Phases Operation

The power supply can also be used on two-phases of a three-phase-system. Such a phase-to-phase connection is allowed as long as the supplying voltage is below $240V^{+10\%}$.

The maximum allowed voltage between a Phase and the PE must be below 300Vac.

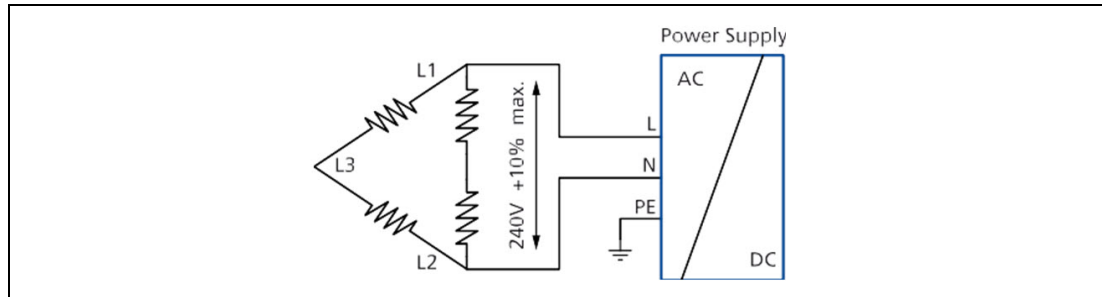

Figure 25.12 Two phases operation

25.9 Use in a Tightly Sealed Enclosure

When the power supply is installed in a tightly sealed enclosure, the temperature inside the enclosure will be higher than outside. In such situations, the inside temperature defines the ambient temperature for the power supply.

The power supply is placed in the middle of the box, no other heat producing items are inside the box. The temperature sensor inside the box is placed in the middle of the right side of the power supply with a distance of 2cm. The following measurement results can be used as a reference to estimate the temperature rise inside the enclosure.

	Case A
Enclosure size	180x180x165mm Rittal Typ IP66 Box PK 9519 100, plastic
Input voltage	230Vac
Load	24V, 16A; (=80%) load is placed outside the box
Temperature inside the box	51.9°C
Temperature outside the box	25.6°C
Temperature rise	26.3K

25.10 Mounting Orientations

Mounting orientations other than all terminals on the bottom require a reduction in continuous output power or a limitation in the maximum allowed ambient temperature.

The amount of reduction influences the lifetime expectancy of the power supply. Therefore, two different derating curves for continuous operation can be found below:

- Curve A1** Recommended output current.
- Curve A2** Max allowed output current (results in approximately half the lifetime expectancy of A1).

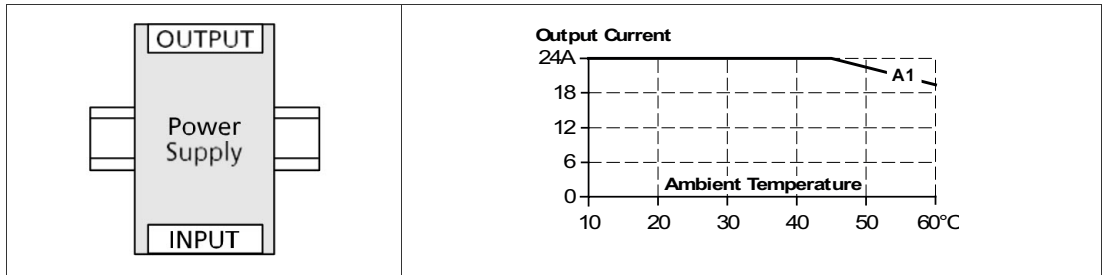

Figure 25.13 Mounting orientation A (standard orientation)

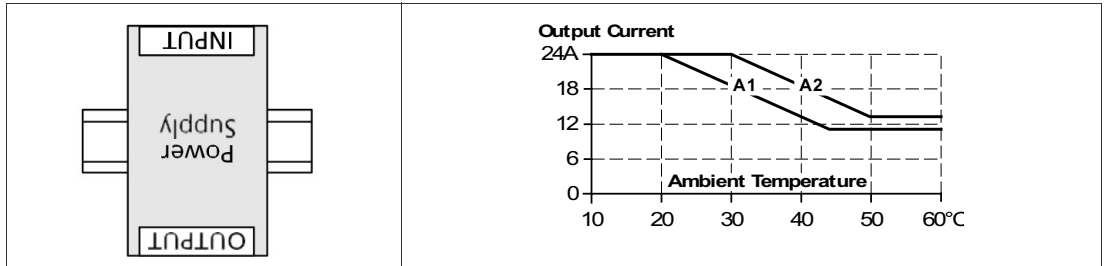

Figure 25.14 Mounting orientation B (upside down)

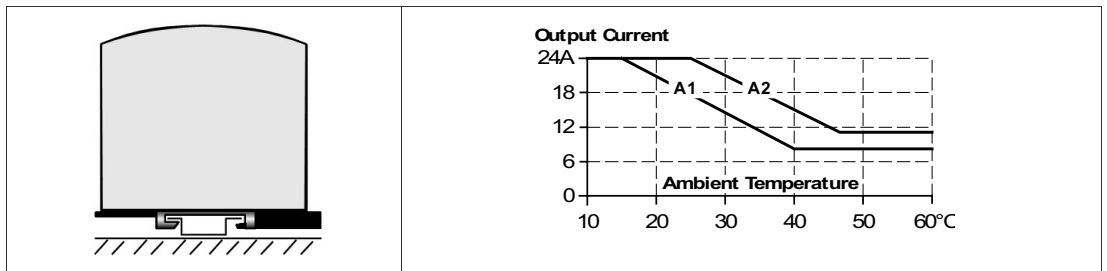

Figure 25.15 Mounting orientation C (table-top mounting)

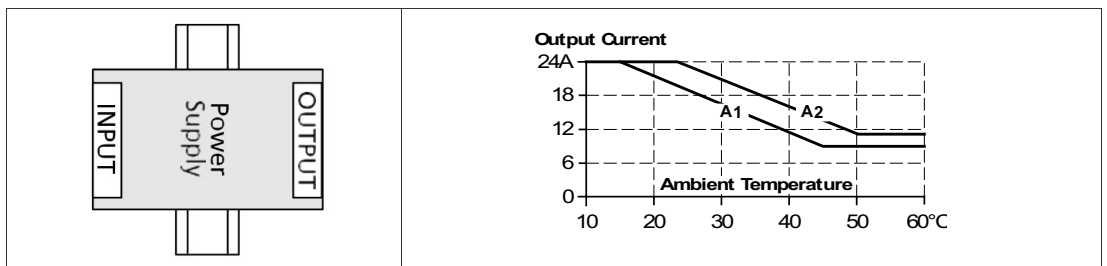

Figure 25.16 Mounting orientation D (horizontal cw)

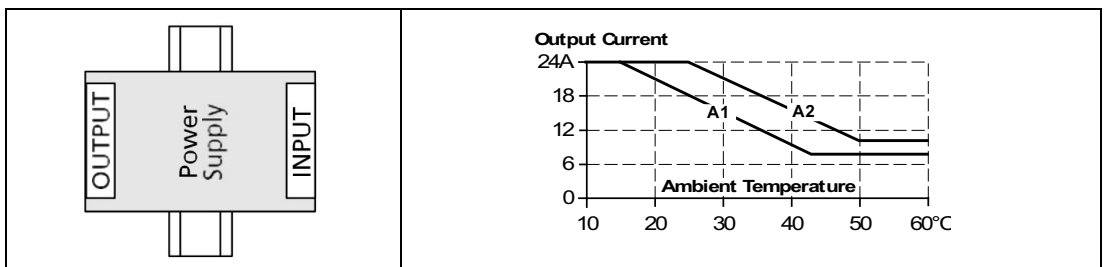

Figure 25.17 Mounting orientation E (horizontal ccw)

Your automation, our passion.

Explosion Protection

- Intrinsic Safety Barriers
- Signal Conditioners
- FieldConnex® Fieldbus
- Remote I/O Systems
- Electrical Ex Equipment
- Purge and Pressurization
- Industrial HMI
- Mobile Computing and Communications
- HART Interface Solutions
- Surge Protection
- Wireless Solutions
- Level Measurement

Industrial Sensors

- Proximity Sensors
- Photoelectric Sensors
- Industrial Vision
- Ultrasonic Sensors
- Rotary Encoders
- Positioning Systems
- Inclination and Acceleration Sensors
- Fieldbus Modules
- AS-Interface
- Identification Systems
- Displays and Signal Processing
- Connectivity

Pepperl+Fuchs Quality

Download our latest policy here:

www.pepperl-fuchs.com/quality

