

PS1000-D2-24.20.RM

Redundancy Module

Technical Information



Your automation, our passion.

 **PEPPERL+FUCHS**

With regard to the supply of products, the current issue of the following document is applicable:
The General Terms of Delivery for Products and Services of the Electrical Industry, published by the Central Association of the Electrical Industry (Zentralverband Elektrotechnik und Elektroindustrie (ZVEI) e.V.) in its most recent version as well as the supplementary clause: "Expanded reservation of proprietorship"

Worldwide

Pepperl+Fuchs Group

Lilienthalstr. 200

68307 Mannheim

Germany

Phone: +49 621 776 - 0

E-mail: info@de.pepperl-fuchs.com

North American Headquarters

Pepperl+Fuchs Inc.

1600 Enterprise Parkway

Twinsburg, Ohio 44087

USA

Phone: +1 330 425-3555

E-mail: sales@us.pepperl-fuchs.com

Asia Headquarters

Pepperl+Fuchs Pte. Ltd.

P+F Building

18 Ayer Rajah Crescent

Singapore 139942

Phone: +65 6779-9091

E-mail: sales@sg.pepperl-fuchs.com

<https://www.pepperl-fuchs.com>

1	Introduction	5
2	Terminology and Abbreviations.	6
3	Intended Use	7
4	Installation Instructions	8
5	Input and Output Characteristics	10
6	Power Losses	12
7	Lifetime Expectancy and MTBF	13
8	Terminals and Wiring.	14
9	Functional Diagram	15
10	Front Side and User Elements	16
11	Redundancy Relay Contact	17
12	Load Share Relay Contact	18
13	Automated Load Sharing	19
14	EMC	20
15	Environment	21
16	Protection Features	22
17	Safety Features	23
18	Dielectric Strength	24
19	Approvals And Fulfilled Standards	25
20	Regulatory Compliance	26
21	Physical Dimensions and Weight	27
22	Application Notes	28

1 Introduction

The information given in this document is correct to the best of our knowledge and experience at the time of publication. If not expressly agreed otherwise, this information does not represent a warranty in the legal sense of the word. As the state of our knowledge and experience is constantly changing, the information in this data sheet is subject to revision. We therefore kindly ask you to always use the latest issue of this document (available under www.pepperl-fuchs.com).

No part of this document may be reproduced or utilized in any form without our prior permission in writing.

2 Terminology and Abbreviations

DC 24V	A figure displayed with the AC or DC before the value represents a nominal voltage with standard tolerances (usually $\pm 15\%$) included. E.g.: DC 12V describes a 12V battery disregarding whether it is full (13.7V) or flat (10V)
24Vdc	A figure with the unit (Vdc) at the end is a momentary figure without any additional tolerances included.
may	A key word indicating flexibility of choice with no implied preference.
shall	A key word indicating a mandatory requirement.
should	A key word indicating flexibility of choice with a strongly preferred implementation.
1+1 Redundancy	Use of two identical power supplies in parallel to provide continued operation following most failures in a single power supply. The two power supply outputs should be isolated from each other by utilizing diodes or other switching arrangements. E.g. two 10A power supplies are needed to achieve a 10A redundant system.

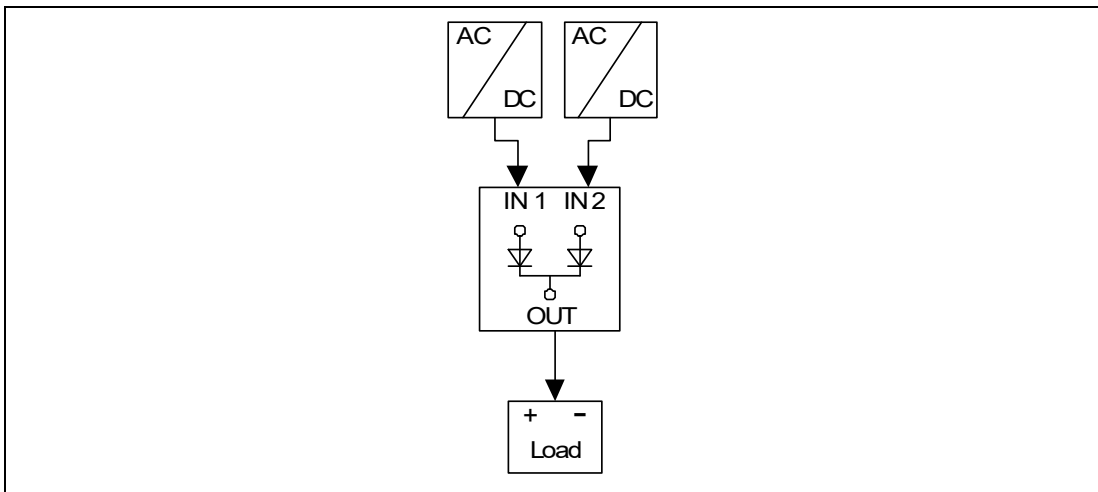

Figure 2.1 1+1 Redundancy

3 Intended Use

This device is designed for installation in an enclosure and is intended for commercial use, such as in industrial control, process control, monitoring and measurement equipment or the like. Do not use this device in equipment where malfunction may cause severe personal injury or threaten human life.

The redundancy module can be used with any type of power supply as long as the maximum output current ratings are not exceeded. It is suitable for power supplies with continuous overload current as well as any kind of intermittent (Hiccup) overload behavior.

Function

The device is a redundancy module for building redundant power supply systems.

The device is equipped with 2 inputs and 1 output. Power supplies with an output current of up to 24 A and one output can be connected to the inputs. The power supplies can transmit a rated current of up to 20 A.

The both inputs are decoupled by MOSFETs. This reduces heat generation and voltage drop between input and output.

The device is mounted on a 35 mm DIN mounting rail according to EN 60715.

Reference Conditions

All parameters are typical values specified at 24V, 20A output current, 25°C ambient and after a 5 minutes run-in time unless otherwise noted.

4 Installation Instructions



Warning!

Risk of electrical shock, fire, personal injury or death.

- Turn power off before working on the device and protect against inadvertent re-powering.
- Do not open, modify or repair the device.
- Use caution to prevent any foreign objects from entering into the housing.
- Do not use in wet locations or in areas where moisture or condensation can be expected.
- Do not touch during power-on, and immediately after power-off.
Hot surface may cause burns.



Warning!

Explosion hazards

- Substitution of components may impair suitability for this environment.
- Do not disconnect the device unless power has been switched off or the area is known to be non-hazardous.
- A suitable enclosure must be provided for the end product which has a minimum protection of IP54 and fulfills the requirements of the EN 60079-0.



Note

If you use the device in hazardous areas, observe the safety information in the instruction manual and in chapter 19.

This device may only be installed and put into operation by qualified personnel.

This device does not contain serviceable parts. The tripping of an internal fuse is caused by an internal defect.

If damage or malfunction should occur during installation or operation, immediately turn power off and send unit to the factory for inspection.

Install the device in an enclosure providing protection against electrical, mechanical and fire hazards.

Do not ground or earth the positive output pole which could prevent redundancy in case of a ground failure. Ground the negative output pole, when needed.

Use only power supplies with a negligible output ripple voltage in the low frequency range between 50Hz and 10kHz when used in marine applications according to the GL regulations.

Install the device onto a DIN-rail according to EN 60715 with the output terminals on the bottom of the device. Other mounting orientations require a reduction in output current.

Make sure that the wiring is correct by following all local and national codes.

Use appropriate copper cables that are designed for a minimum operating temperature of 60°C for ambient temperatures, up to +45°C, 75°C for ambient temperatures up to +60°C and 90°C for ambient temperatures up to +70°C. Ensure that all strands of a stranded wire enter the terminal connection.

Unused screw terminals should be securely tightened.

The device is designed for pollution degree 2 areas in controlled environments. No condensation or frost is allowed.

The enclosure of the device provides a degree of protection of IP20.

The input must be powered from a PELV or SELV source or an **Isolated Secondary Circuit** in order to maintain a SELV or PELV output.

Check correct input polarity. The device will not operate when input voltage is reversed.

The device is designed as **Class of Protection III** equipment according to IEC 61140.

A PE (ground) connection is not required. However, connecting the chassis ground terminal to ground can be beneficial to gain a high EMI immunity.

The device is designed for convection cooling and does not require an external fan. Do not obstruct airflow and do not cover ventilation grid!

The device is designed for altitudes up to 6000m (19685ft). See additional requirements in the product datasheet for use above 2000m (6560ft).

Keep the following minimum installation clearances: 40mm on top, 20mm on the bottom, 5mm left and right side. Increase the 5mm to 15mm in case the adjacent device is a heat source. When the device is permanently loaded with less than 50%, the 5mm can be reduced to zero. Under special circumstances clearances can be reduced. See details in the product datasheet.

The maximum surrounding air temperature is +70°C (+158°F). The operational temperature is the same as the ambient or surrounding air temperature and is defined 2cm below the device.

The device is designed to operate in areas between 5% and 95% relative humidity.

To ensure a proper load share function, ensure that the wiring size and length between the two power supplies and the redundancy module is identical.

5 Input and Output Characteristics

Number of inputs		2	
Number of outputs		1	
Input voltage	nom.	DC 24-28V \pm 25%	
Input voltage range		18-35Vdc	
Voltage drop, input to output	typ.	0.1-0.5V	at 2x5A, load share function dependent, see Figure 5.1
	typ.	0.2-0.5V	at 2x10A, load share function dependent, see Figure 5.1
	typ.	0.24-0.5V	at 2x12A, load share function dependent, see Figure 5.1
Input current	nom.	2x 0-12A	continuous, ambient temperature < +45°C
	nom.	2x 0-10A	continuous, ambient temperature < +70°C
	nom.	2x 17A ¹	for max. 5 seconds
	max.	2x 700A	for max. 1ms
Output current	nom.	24A	continuous, ambient temperature < +45°C
	nom.	20A	continuous, ambient temperature < +70°C
	nom.	32.5A	for max. 5 seconds
	max.	26A	in overload /short-circuit (voltage < 6V). Ensure that the sum of input currents does not exceed this value.
Reverse current	max.	1mA	at 24V, per input, -40°C to +70°C
Reverse voltage	max.	40Vdc	voltage applied to the output, continuously allowed
Output capacitance	typ.	320 μ F	

¹ The average value (R.M.S. value) of the output current must not exceed the values of the continuous output current.

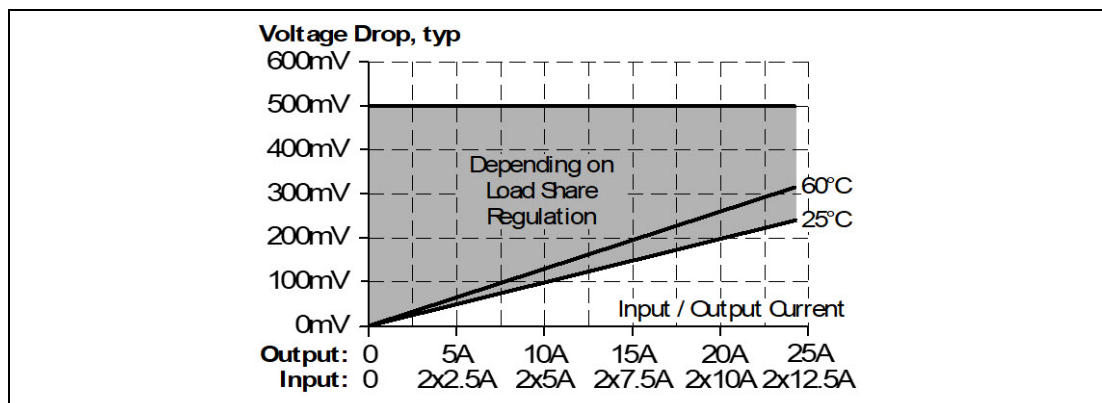

Figure 5.1 Input to output voltage drop

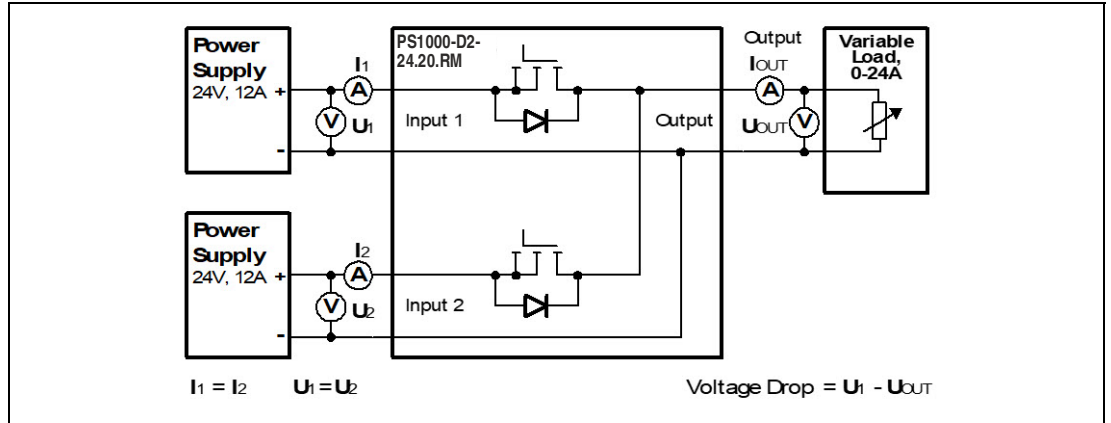

Figure 5.2 Test setup for voltage drop measurements

6 Power Losses

Power losses	typ. 2.6-4.7W	at 2x5A, 25°C ambient temperature
	typ. 5.6-8.7W	at 2x10A, 25°C ambient temperature
Standby power losses	typ. 1.7W	at no output current

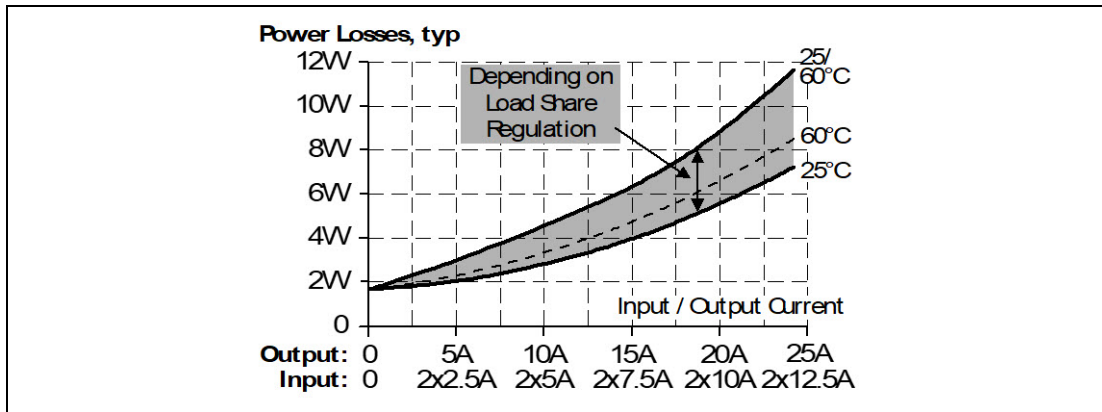

Figure 6.1 Power losses

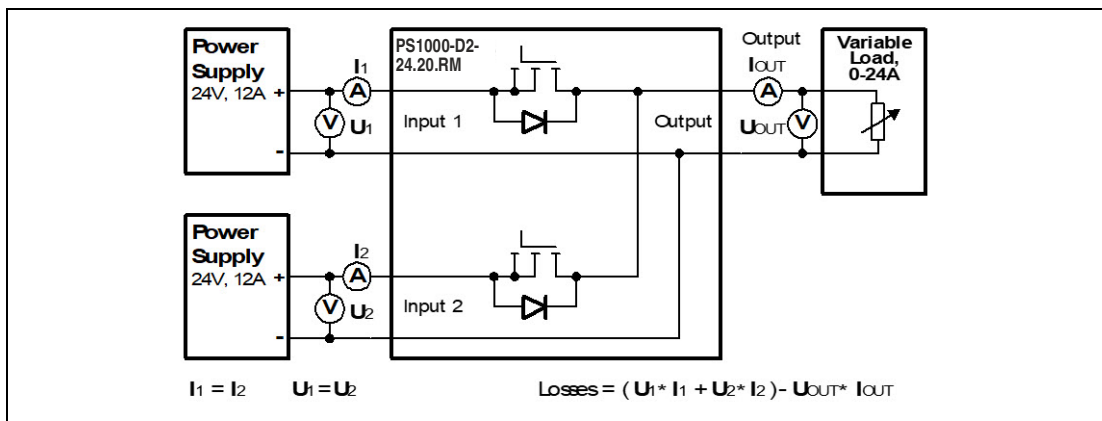

Figure 6.2 Test setup for power loss measurements

7 Lifetime Expectancy and MTBF

The redundancy module has two input channels which are completely independent from each other. Each control circuit, auxiliary voltage source, or other circuitry in the module are designed separately for each input. The dual input redundancy module can be considered as two single redundancy modules combined together in one housing. The only common point is the circuit trace that ties the two separate circuits together at the output.

The MTBF figures below are for the entire dual input module. If the MTBF number of only one path is needed, simply double the value from the table.

Input / output current conditions	Input: 2x5A Output: 10A	Input: 2x10A Output: 20A	
Lifetime expectancy ¹	372 000h ¹	182 000h ¹	at 24V and 40°C
	1 053 000h ¹	516 000h ¹	at 24V and 25°C
MTBF ² SN 29500, IEC 61709	2 306 000h	1 954 000h	at 24V and 40°C
	3 913 000h	3 359 000h	at 24V and 25°C
MTBF ² MIL HDBK 217F	964 000h	858 000h	Ground Fixed GF40 (24V and 40°C)
	1 379 000h	1 226 000h	Ground Fixed GF25 (24V and 25°C)
	278 000h	243 000h	Ground Benign GB40 (24V and 40°C)
	381 000h	330 000h	Ground Benign GB25 (24V and 25°C)

¹ The **Lifetime expectancy** shown in the table indicates the minimum operating hours (service life) and is determined by the lifetime expectancy of the built-in electrolytic capacitors. Lifetime expectancy is specified in operational hours and is calculated according to the capacitor's manufacturer specification. The manufacturer of the electrolytic capacitors only guarantees a maximum life of up to 15 years (131 400h). Any number exceeding this value is a calculated theoretical lifetime which can be used to compare devices.

² **MTBF** stands for **Mean Time Between Failure**, which is calculated according to statistical device failures, and indicates reliability of a device. It is the statistical representation of the likelihood of a unit to fail and does not necessarily represent the life of a product. The MTBF figure is a statistical representation of the likelihood of a device to fail. A MTBF figure of e.g. 1 000 000h means that statistically one unit will fail every 100 hours if 10 000 units are installed in the field. However, it can not be determined if the failed unit has been running for 50 000h or only for 100h.

8 Terminals and Wiring

	Input and Output	Signals
Type	Screw termination IP20 Finger safe construction. Suitable for field installation.	Push-in terminals
Solid wire	max. 6mm ²	max. 1.5mm ²
Stranded wire	max. 4mm ²	max. 1.5mm ²
American Wire Gauge	20-10 AWG	AWG 24-16
Max. wire diameter	2.8mm (including ferrule)	max. 1.6mm (including ferrules)
Wire stripping length	7mm / 0.28inch	7mm / 0.28inch
Screwdriver	3.5mm slotted or Pozidrive No 2	not required
Recommended tightening torque	0.8Nm, 7lb.in	not applicable



Connecting Terminals

1. Use appropriate copper cables that are designed for minimum operating temperatures of:
 - 60°C for ambient up to 45°C and
 - 75°C for ambient up to 60°C minimum
 - 90°C for ambient up to 70°C minimum.
2. Follow national installation codes and installation regulations!
3. Ensure that all strands of a stranded wire enter the terminal connection!
4. Screws of unused terminal compartments should be securely tightened.
5. Ferrules are allowed.

9 Functional Diagram

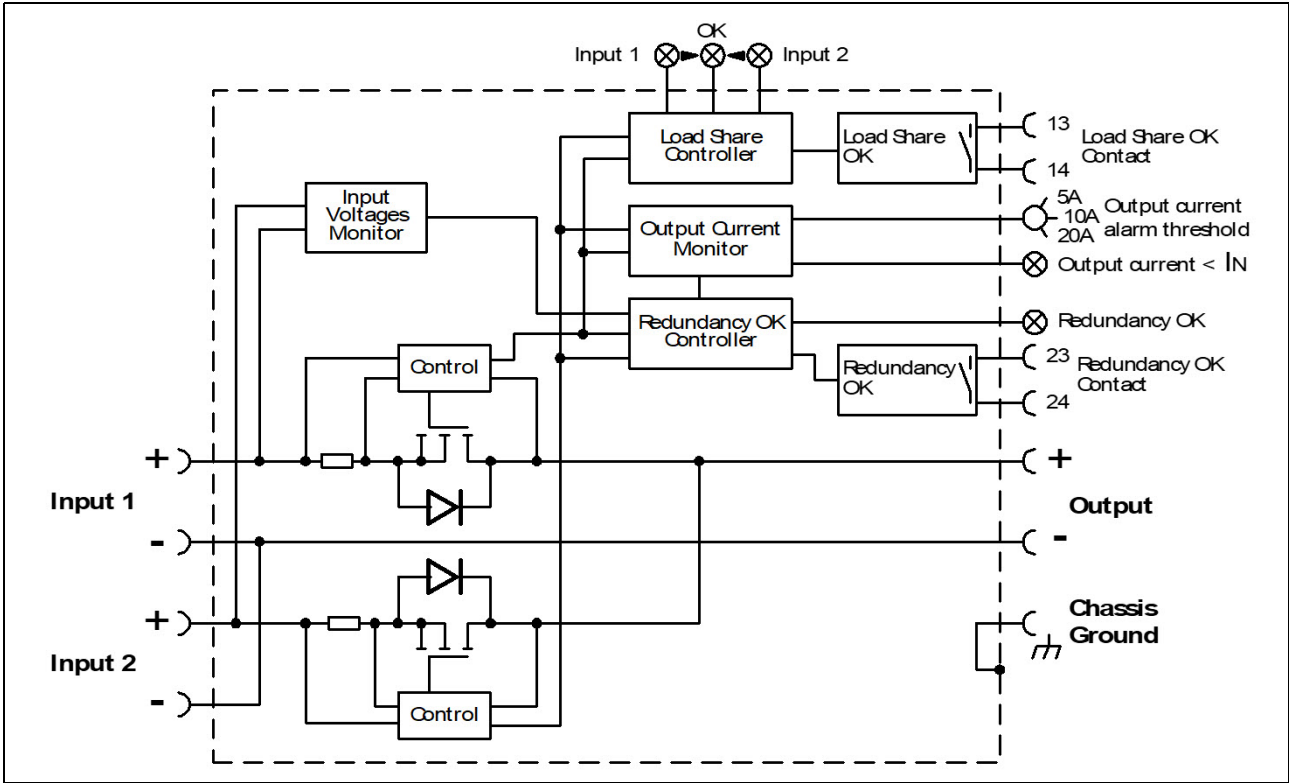

Figure 9.1 Functional diagram

10 Front Side and User Elements

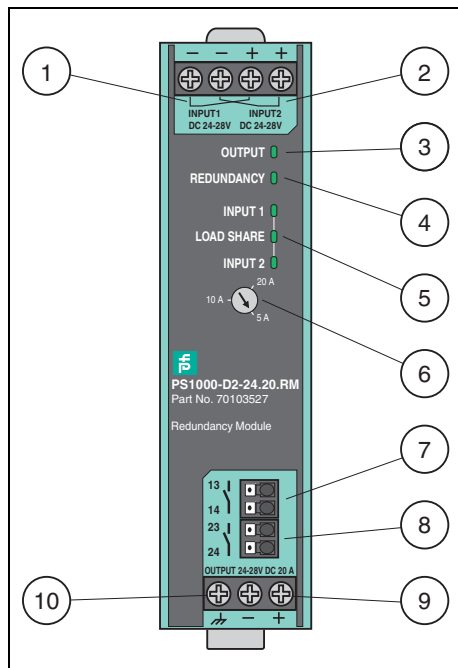

Figure 10.1 Front side

- 1 Input terminals for input 1** (screw terminals)
- 2 Input terminals for input 2** (screw terminals)
- 3 Green LED Output**
The LED is on solid when the output current is smaller than the adjusted value of the output current alarm selector (6).
- 4 Green LED Redundancy**
The LED is on solid when no errors are detected.
Errors:
 - One or both input voltages are out of range (below 22V or above 30V).
 - Output current is higher than the adjusted value of the output current threshold setting.
 - Internal defect is detected
- 5 Load share LEDs**
The three LEDs indicate the status of the load sharing between the two power supplies.
See chapter 13 for detailed description.
- 6 Selector for output current warning threshold**
If the output current increases, e. g. due to additionally loads, and exceeds the nominal current of one power supply unit, redundancy is no longer guaranteed. To avoid the loss in redundancy, the output current is monitored and is reported through LEDs and relay contacts when exceeding the predefined value.
 - Set the selector to 5A in combination with two 5A power supplies (1+1 red.)
 - Set the selector to 10A in combination with two 10A power supplies (1+1 red.)
 - Set the selector to 20A for n+1 redundant system. With this setting, redundancy cannot be checked by the redundancy module anymore. Exceeding the current by less than 2 seconds will be ignored.
- 7 Load share relay contact** (push-in terminals)
The relay contact is closed when the output voltage of the two power supplies are sufficiently adjusted. Deviations less than 2s will be ignored.
See chapter 13 for detailed description.
See chapter 12 for contact ratings.
- 8 Redundancy relay contact** (push-in terminals)
The relay contact is closed when no redundancy errors are detected. The relay contact is also synchronized with the **Redundancy LED**.
See chapter 11 for contact ratings.
- 9 Output terminals** (screw terminals)
- 10 Chassis-ground terminal** (screw terminal)
Connection of the chassis is optional and not required since the unit fulfills the requirements according to protection class III.

11 Redundancy Relay Contact

This feature reports the loss of redundancy by opening the relay contact (pin 23 and 24).

Contact is closed	When no errors are detected						
Contact is open	<p>When:</p> <ul style="list-style-type: none"> • one or both input voltages are below 22Vdc or above 30Vdc. • the output current is higher than the adjusted value of the output current threshold setting. • an internal defect of the redundancy module is detected (decoupling measures and several internal test routines). <p>Input voltage errors less than 2s will be ignored. Overcurrent errors (less than 150% of the adjusted value) less than 4s will be ignored. Overcurrent errors (above 150% of the adjusted value) less than 30ms will be ignored. Internal errors less than 10s will be ignored</p>						
Contact ratings	<table> <tr> <td>max.</td> <td>60Vdc 0.3A, 30Vdc 1A, 30Vac 0.5A</td> <td>resistive load</td> </tr> <tr> <td>min.</td> <td>1mA at 5Vdc</td> <td>minimum permissible load</td> </tr> </table>	max.	60Vdc 0.3A, 30Vdc 1A, 30Vac 0.5A	resistive load	min.	1mA at 5Vdc	minimum permissible load
max.	60Vdc 0.3A, 30Vdc 1A, 30Vac 0.5A	resistive load					
min.	1mA at 5Vdc	minimum permissible load					
Isolation voltage	See dielectric strength table in chapter 18.						

12 Load Share Relay Contact

This feature monitors if the output voltages of the two power supplies connected to the input are sufficiently adjusted for an even current distribution. The relay contact (pin 13 and 14) is closed, when load sharing occurs.

Contact is closed	When the adjustment of the output voltages are sufficient						
Contact is open	When an even load share does not occur, and readjustment of the output voltages is recommended. Details see chapter 13.						
Contact ratings	<table border="0"> <tr> <td>max.</td> <td>60Vdc 0.3A, 30Vdc 1A, 30Vac 0.5A</td> <td>resistive load</td> </tr> <tr> <td>min.</td> <td>1mA at 5Vdc</td> <td>minimum permissible load</td> </tr> </table>	max.	60Vdc 0.3A, 30Vdc 1A, 30Vac 0.5A	resistive load	min.	1mA at 5Vdc	minimum permissible load
max.	60Vdc 0.3A, 30Vdc 1A, 30Vac 0.5A	resistive load					
min.	1mA at 5Vdc	minimum permissible load					
Isolation voltage	See dielectric strength table in chapter 18.						

13 Automated Load Sharing

Drawing even current from both power supplies in a redundancy application can provide a longer service life of the redundant power supply system. An evenly shared current can avoid that one of the two units is getting much hotter than the other, which reduces the lifetime of the power supply system. The redundancy module is equipped with an automated load share feature, which can compensate a certain voltage unbalance between the two power supplies connected to the inputs.

However, to reduce the losses of the active circuit in the redundancy module, the individual output voltages shall be set as close as possible. The three LEDs on the front of the unit help to indicate if adjustment is necessary.

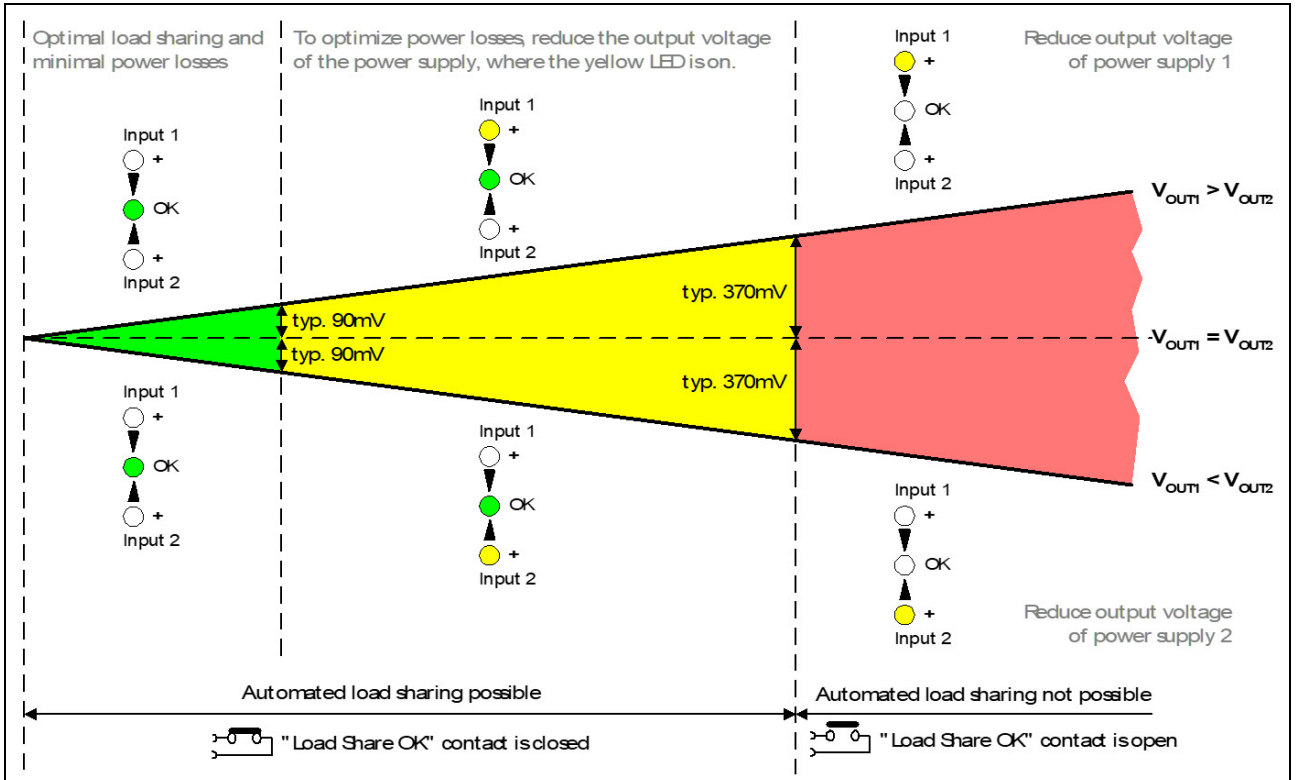

Figure 13.1 Functional diagram

The active load share feature of the device has a similar effect and benefit as the feature **Parallel Mode** (soft output characteristic), which is available on larger power supplies.

14 EMC

The redundancy module is suitable for applications in industrial environment as well as in residential, commercial and light industry environment without any restrictions.

EMC Immunity	According to generic standards: EN 61000-6-1 and EN 61000-6-2			
Electrostatic discharge	EN 61000-4-2	Contact discharge Air discharge	8kV 15kV	Criterion A Criterion A
Electromagnetic RF field	EN 61000-4-3	80MHz-2.7GHz	10V/m	Criterion A
Fast transients (Burst)	EN 61000-4-4	Input lines Output lines Redundancy OK signal ¹ Load share OK signal ¹	2kV 2kV 2kV 2kV	Criterion A Criterion A Criterion A Criterion A
Surge voltage on input lines	EN 61000-4-5	+ → - + / - → Chassis ground	500V 1kV	Criterion A Criterion A
Surge voltage on output lines	EN 61000-4-5	+ → - + / - → Chassis ground	500V 1kV	Criterion A Criterion A
Surge voltage on signal lines	EN 61000-4-5	Load Share OK signal → PE Redundancy OK signal	1kV 1kV	Criterion A Criterion A
Conducted disturbance	EN 61000-4-6	0.15-80MHz	20V	Criterion A
Power-frequency magnetic field ²	EN 61000-4-8	50Hz	30A/m	Criterion A

¹ Tested with capacitive coupling clamp.

² A test is not applicable according to EN 61000-6-2, since the device does not contain components susceptible to magnetic fields, e.g. hall elements, electrodynamic microphones, etc.

Criterion A Redundancy module shows normal operation behavior within the defined limits.

EMC Emission	According to generic standards: EN 61000-6-3 and EN 61000-6-4	
Conducted emission input lines	IEC/CISPR 16-1-2, IEC/CISPR 16-2-1	Limits for DC power port according EN 61000-6-3 fulfilled ^{1 2}
Conducted emission output lines	IEC/CISPR 16-1-2, IEC/CISPR 16-2-1	Limits for DC power port according EN 61000-6-3 fulfilled ^{1 2}
Radiated emission	EN 55011, EN 55022	Class B ²

This device complies with FCC Part 15 rules.

Operation is subjected to following two conditions: (1) this device may not cause harmful interference, and (2) this device must accept any interference received, including interference that may cause undesired operation.

¹ For information only, not mandatory for EN 61000-6-3.

² Provided, that power sources connected on the inputs fulfill the requirements too.

Switching frequency

The internal auxiliary supply is generated with a boost converter.
The switching frequency varies from 140kHz to 500kHz depending on the input voltage.

15 Environment

Operational temperature ¹	-40°C to +70°C (-40°F to 158°F)	
Storage temperature	-40 to +85°C (-40°F to 185°F)	for storage and transportation
Humidity ²	5 to 95% r.H.	IEC 60068-2-30
Vibration sinusoidal ³	2-17.8Hz: ±1.6mm; 17.8-500Hz: 2g 2 hours / axis	IEC 60068-2-6
Shock ³	30g 6ms, 20g 11ms 3 bumps / direction, 18 bumps in total	IEC 60068-2-27
Altitude	0 to 2000m (0 to 6 560ft) 2000 to 6000m (6 560 to 20 000ft)	without any restrictions reduce output power or ambient temperature, see Figure 15.2
Altitude de-rating	1.25A/1000m or 5°C/1000m	> 2000m (6500ft), see Figure 15.2
Over-voltage category	not applicable	The concept of the overvoltage category is used for equipment energized directly from the low voltage mains (IEC 60664-1 §4.3.3.2.1).
Degree of pollution	2	EN 62477-1, not conductive

¹ Operational temperature is the same as the ambient or surrounding temperature and is defined as the air temperature 2cm below the unit.

² Do not energize while condensation is present.

³ Tested in combination with DIN mounting rails according to EN 60715 with a height of 15mm and a thickness of 1.3mm and standard orientation.

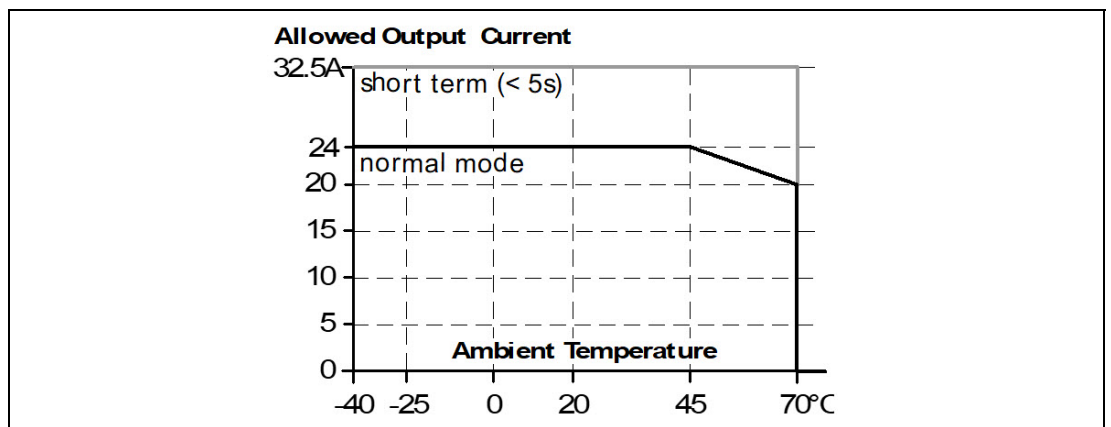

Figure 15.1 Output current vs. ambient temp.

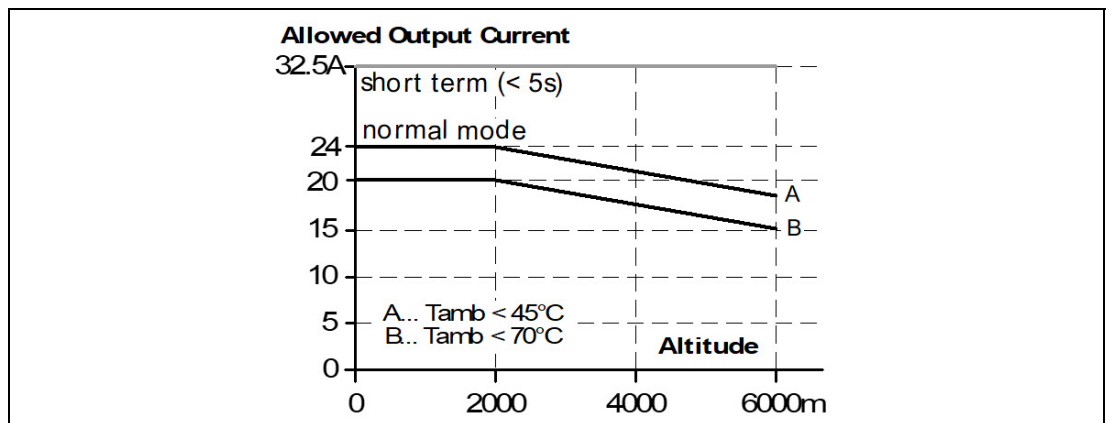

Figure 15.2 Output current vs. altitude

16 Protection Features

Output over-current protection	not included	
Reverse input polarity protection	included	unit does not start when input voltage is reversed
Degree of protection	IP 20	EN/IEC 60529
Penetration protection	> 3.6mm	e.g. screws, small parts
Over-temperature protection	not included	
Input transient protection	included	see EMC section
Output transient protection	included	see EMC section
Internal input fuse	not included	

17 Safety Features

Input / output separation	no galvanic separation	Mosfet between input and output
Safety level of output voltage	The output voltage is regarded to be SELV (EN 60950-1) or PELV (EN 60204-1, EN 62477-1, IEC 60364-4-41) if the input voltage fulfills the requirements for a SELV source or PELV source.	
Class of protection	III	PE (Protective Earth) or chassis connection not required
PE resistance	< 0.1Ohm	between housing and chassis-ground terminal

18 Dielectric Strength

The input and output voltages have the same reference, are floating and have no ohmic connection to ground.

Type and factory tests are conducted by the manufacturer. Field tests may be conducted in the field using the appropriate test equipment which applies the voltage with a slow ramp (2s up and 2s down). Connect input/output and signal terminals together before conducting the test.

When testing, set the cut-off current settings to the value in the table below.

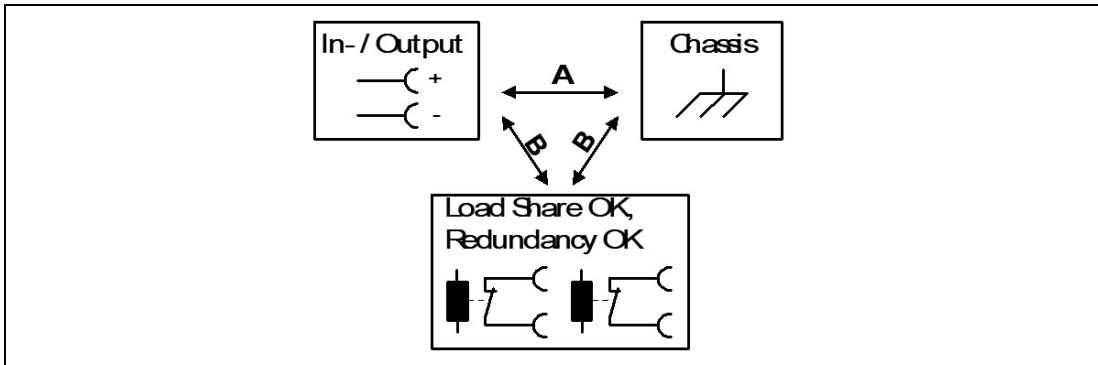

Figure 18.1 Dielectric strength

		A	B
Type test	60s	500Vac	500Vac
Factory test	5s	500Vac	500Vac
Field test	5s	500Vac	500Vac
Cut-off current setting		> 2mA	> 2mA

19 Approvals And Fulfilled Standards

UL 61010



UL Certificate
Listed equipment for category NMTR - UL 61010-2-201
Electrical Equipment for Measurement, Control and
Laboratory Use - Particular requirements for control
equipment
Applicable for US and Canada
E-File: E223176

EN 60079-0:2012+A11:2013 ,
EN 60079-7:2016 ,
EN 60079-15:2010



ATEX certificate: EPS 11 ATEX 1312 X
ATEX marking: Ⓔ II 3G Ex ec nC II T4 Gc

IEC 60079-0:2011 ,
IEC 60079-7:2015 ,
IEC 60079-15:2010



IECEx certificate: IECEx EPS 20.0057X
IECEx marking: Ex ec nC IIC T4 Gc

20 Regulatory Compliance

EU Declaration of
Conformity



The CE mark indicates conformance with the European

- ATEX directive
- EMC directive
- Low-voltage directive (LVD)
- RoHS directive

WEEE Directive



Manufacturer's Statement

EU-Regulation on Waste Electrical and Electronic
Equipment Registered in Germany as business to business
(B2B) products.

REACH Directive



Manufacturer's Statement

EU-Regulation regarding the Registration, Evaluation,
Authorization and Restriction of Chemical

EAC TR Registration



EAC Certificate

EAC EurAsian Conformity Registration Russia, Kazakhstan
and Belarus

21 Physical Dimensions and Weight

Width	32mm, 1.26 inch
Height	124mm, 4.88 inch
Depth	117mm, 4.61 inch The DIN mounting rail height must be added to the unit depth to calculate the total required installation depth.
Weight	310g/0.69lb
DIN mounting rail	Use 35mm DIN mounting rails according to EN 60715 or EN 50022 with a height of 7.5 or 15mm.
Housing material	Body: Aluminium alloy Cover: zinc-plated steel
Installation instructions	See chapter 4.

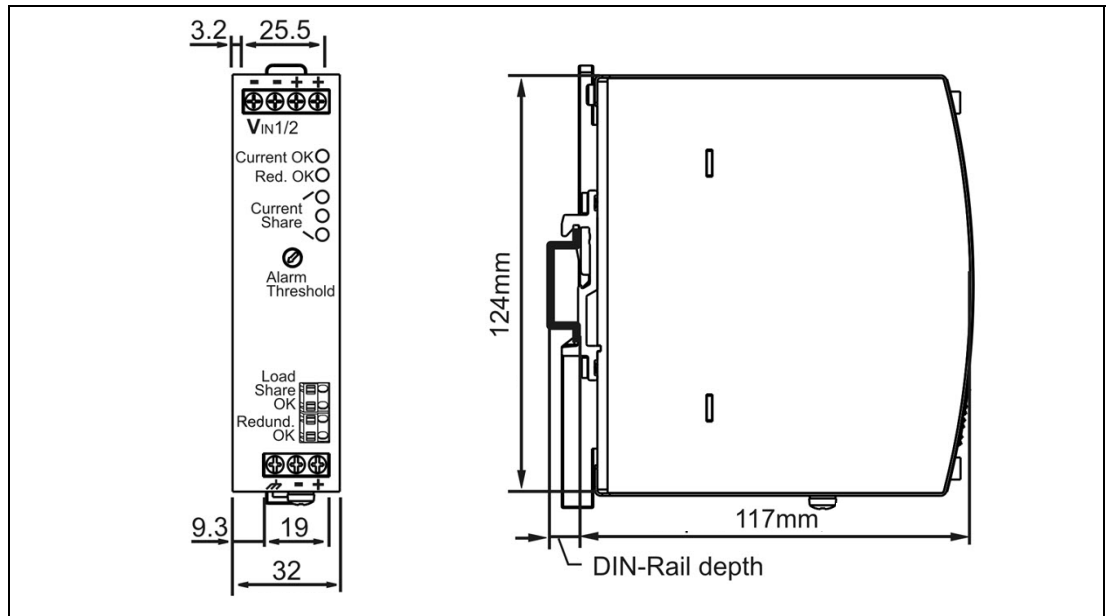

Figure 21.1 Device dimensions, all dimensions in mm

22 Application Notes

22.1 Using Only One Input Instead of Both Channels

Using only one input instead of both is allowed up to a nominal input current of 12A (at max. +45°C ambient temperature) or 10A (at max. +70°C ambient temperature).

The load share feature is disabled in cases one input voltage is not present or the level of the input voltage is below a certain value. The MOSFET will be on in such cases.

However, it is always recommended to connect both input path in parallel for reduced power losses and voltage drop. When this is not possible, the following values can be expected:

Voltage drop, input to output	typ.	0.15V	at 1x10A, 25°C, see Figure 22.1
Power losses	typ.	2.6W	at 1x10A, 25°C, see Figure 22.3
Standby power losses	typ.	1.1W	

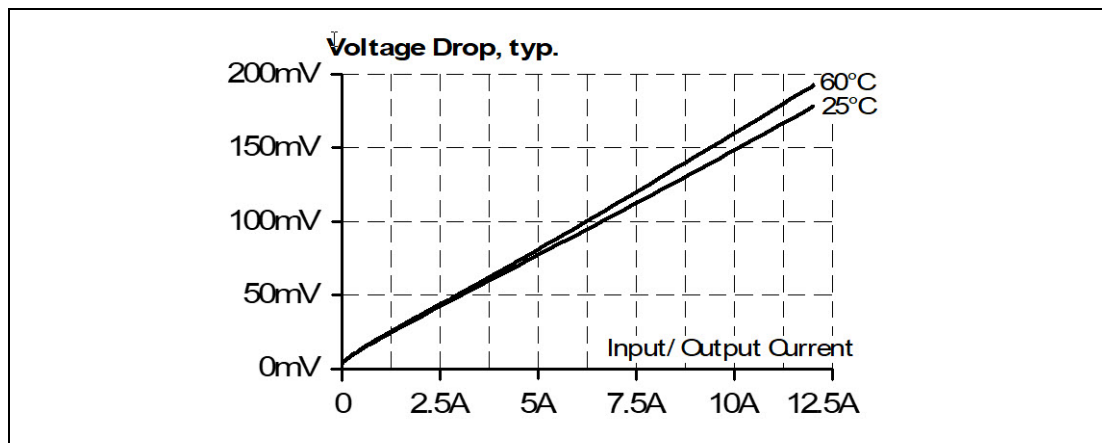

Figure 22.1 Input to output voltage drop when only one input is used

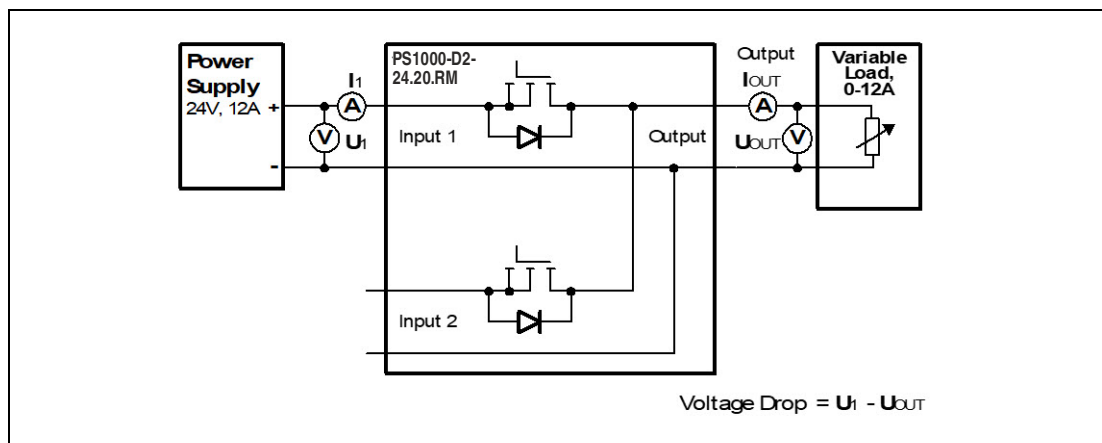

Figure 22.2 Test setup for voltage drop measurements

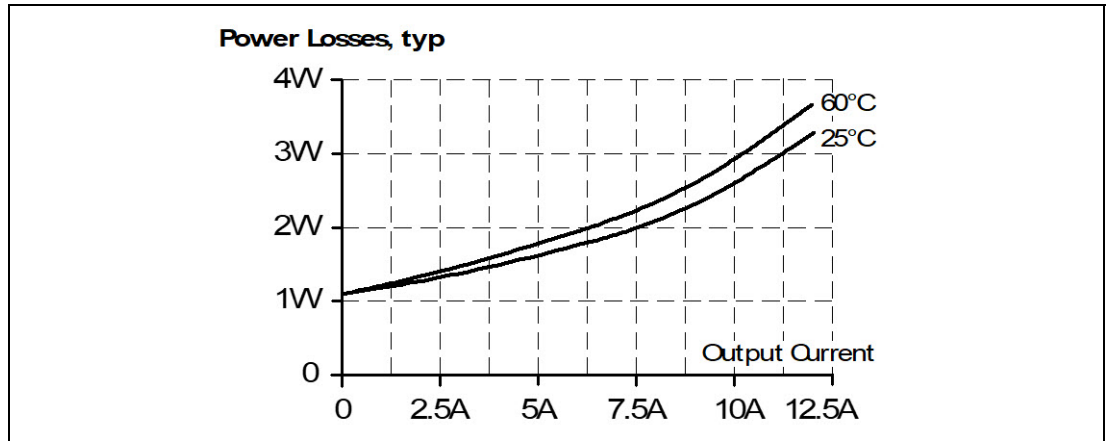

Figure 22.3 Power losses when only one input is used

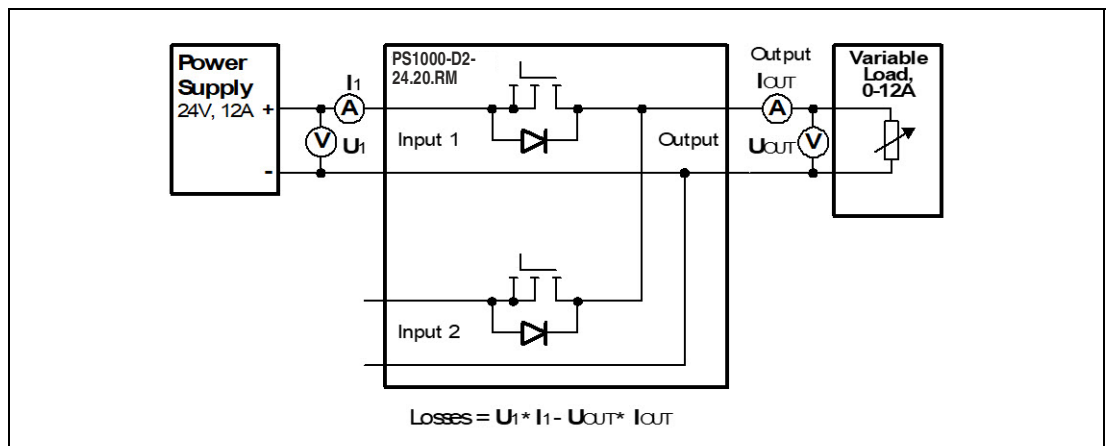

Figure 22.4 Test setup for power loss measurements

22.2 Recommendations for Redundancy

Recommendations for the configuration of redundant power systems:

- Use separate input fuses for each power supply.
- Use three-phase power supplies to gain functional safety if one phase fails.
- When single-phase power supplies are utilized connect them to different phases or mains circuits if possible.
- Set the power supply in **Parallel Use** mode if this feature is available
- It is desirable to set the output voltages of all power supplies to the same value.

22.3 Inductive and Capacitive Loads

The unit is designed to supply any kind of loads, including unlimited capacitive and inductive loads.

22.4 Sideward Installation Clearances

The minimum clearance recommendations are defined in chapter 2.

Normally, the following installation clearance are recommended: 40mm on top, 20mm on the bottom, 5mm on the left and right sides when the device is loaded permanently with more than 50% of the rated power. Increase this clearance to 15mm in case the adjacent device is a heat source (e.g. another power supply).

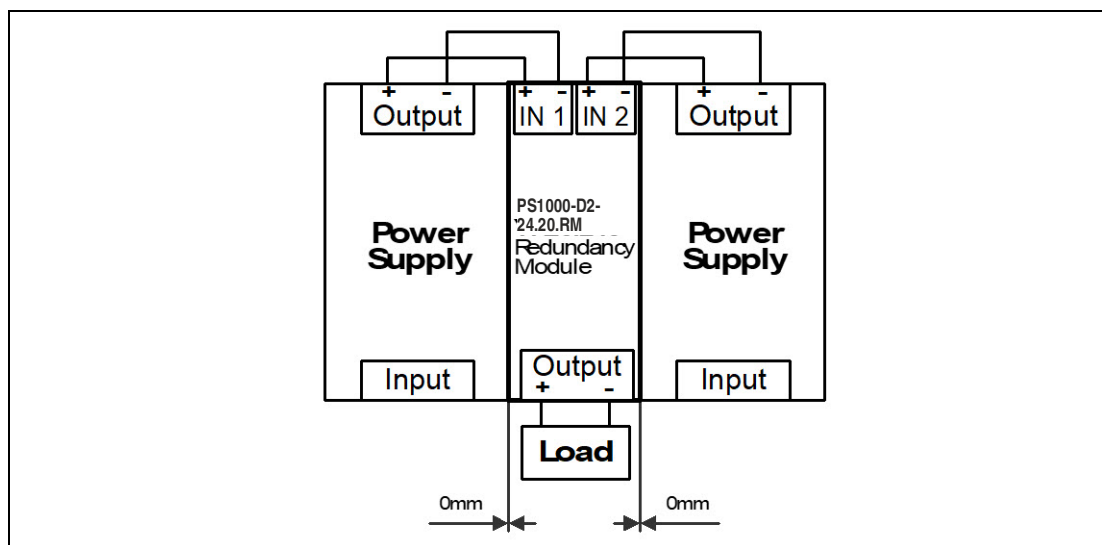

Figure 22.5 30A peak current for 12ms , typ. (3x the nominal current)

The clearance between the power supplies and the redundancy module can be reduced to zero under the following conditions:

- 1+1 redundancy application with maximum 12A output current.
- The power supplies are from the PS1000 series.
- The redundancy module is placed between the two power supplies.
- The output voltage is set to the same level on both power supplies.

22.5 1+1 Redundancy up to 10A

1+1 Redundancy up to 10A requires two 10A power supplies and one redundancy module.

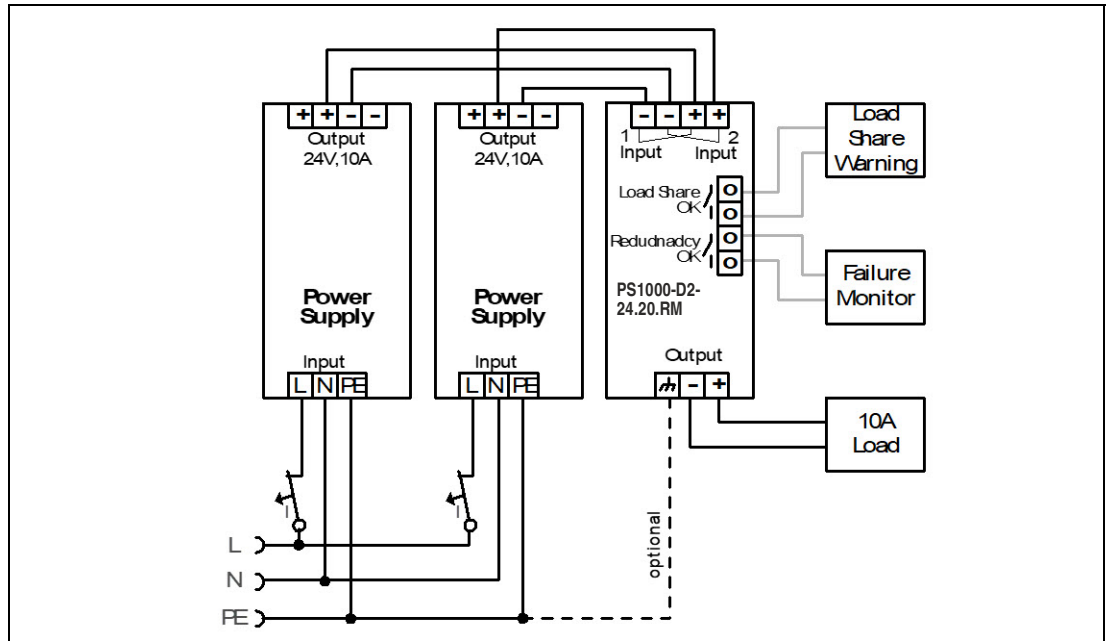

Figure 22.6 Wiring diagram, 1+1 Redundancy, 10A output current



Note

Use separate mains systems for each power supply whenever it is possible.

22.6 Mounting Orientations

Mounting orientations other than all terminals on the bottom require a reduction in continuous output power or a limitation in the maximum allowed ambient temperature. The amount of reduction influences the lifetime expectancy of the power supply. Therefore, two different derating curves for continuous operation can be found below:

Curve A1 Recommended output current.

Curve A2 Max allowed output current (results in approximately half the lifetime expectancy of A1).

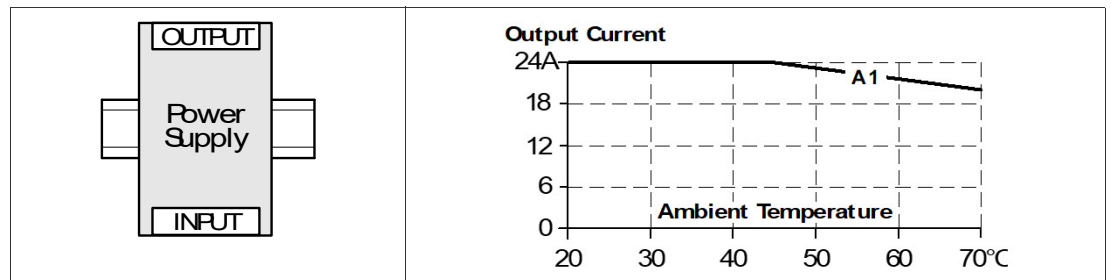

Figure 22.7 Mounting orientation A (standard orientation)

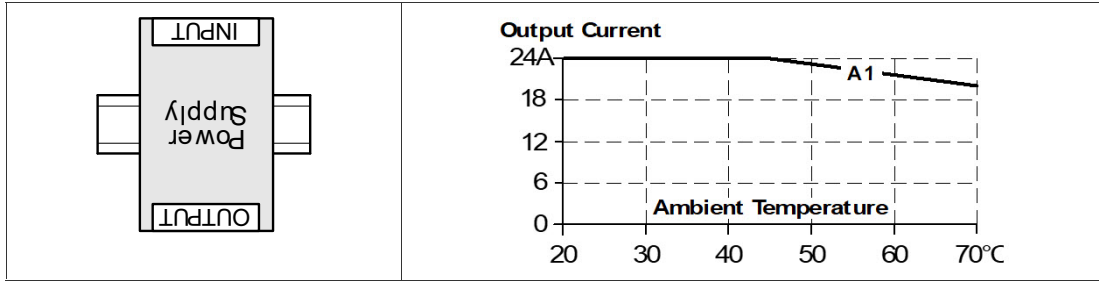

Figure 22.8 Mounting orientation B (upside down)

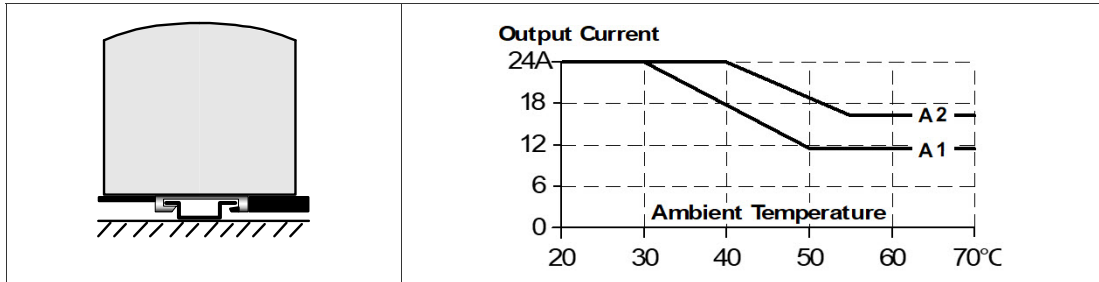

Figure 22.9 Mounting orientation C (table-top mounting)

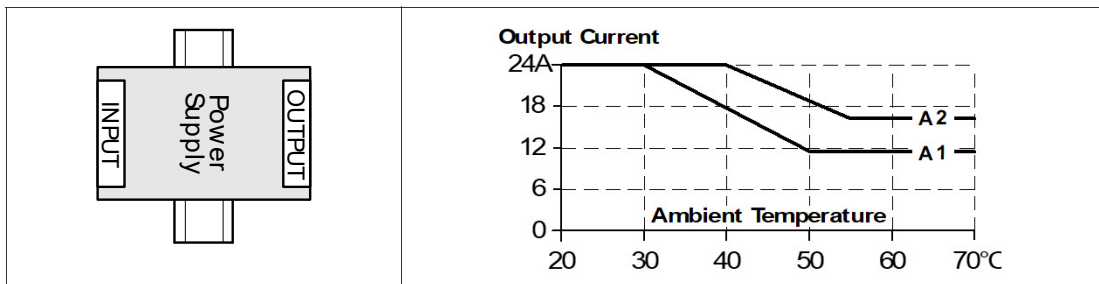

Figure 22.10 Mounting orientation D (horizontal cw)

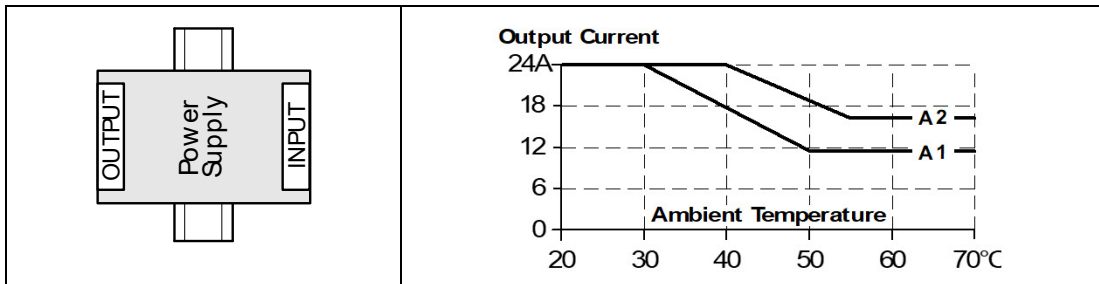

Figure 22.11 Mounting orientation E (horizontal ccw)

Your automation, our passion.

Explosion Protection

- Intrinsic Safety Barriers
- Signal Conditioners
- FieldConnex® Fieldbus
- Remote I/O Systems
- Electrical Ex Equipment
- Purge and Pressurization
- Industrial HMI
- Mobile Computing and Communications
- HART Interface Solutions
- Surge Protection
- Wireless Solutions
- Level Measurement

Industrial Sensors

- Proximity Sensors
- Photoelectric Sensors
- Industrial Vision
- Ultrasonic Sensors
- Rotary Encoders
- Positioning Systems
- Inclination and Acceleration Sensors
- Fieldbus Modules
- AS-Interface
- Identification Systems
- Displays and Signal Processing
- Connectivity

Pepperl+Fuchs Quality

Download our latest policy here:

www.pepperl-fuchs.com/quality

