

PS1000-D2-24.10

DC/DC Converter

Technical Information



Your automation, our passion.

 **PEPPERL+FUCHS**

With regard to the supply of products, the current issue of the following document is applicable:
The General Terms of Delivery for Products and Services of the Electrical Industry, published by the Central Association of the Electrical Industry (Zentralverband Elektrotechnik und Elektroindustrie (ZVEI) e.V.) in its most recent version as well as the supplementary clause: "Expanded reservation of proprietorship"

Worldwide

Pepperl+Fuchs Group
Lilienthalstr. 200
68307 Mannheim
Germany
Phone: +49 621 776 - 0
E-mail: info@de.pepperl-fuchs.com

North American Headquarters

Pepperl+Fuchs Inc.
1600 Enterprise Parkway
Twinsburg, Ohio 44087
USA
Phone: +1 330 425-3555
E-mail: sales@us.pepperl-fuchs.com

Asia Headquarters

Pepperl+Fuchs Pte. Ltd.
P+F Building
18 Ayer Rajah Crescent
Singapore 139942
Phone: +65 6779-9091
E-mail: sales@sg.pepperl-fuchs.com
<https://www.pepperl-fuchs.com>

1	Introduction	5
2	Terminology and Abbreviations.	6
3	Intended Use	7
4	Installation Instructions	8
5	DC Input	10
6	Input Inrush Current	12
7	Soft-Start Feature	13
8	Output	14
9	Hold-Up Time	16
10	Efficiency and Power Losses	17
11	Functional Diagram	19
12	Front Side and User Elements	20
13	Connection Terminals	21
14	Lifetime Expectancy	22
15	MTBF	23
16	EMC	24
17	Environment	25
18	Safety and Protection Features	27
19	Dielectric Strength	28
20	Approvals	29
21	Other Fulfilled Standards	30
22	Physical Dimensions and Weight	31
23	Application Notes	32

1 Introduction

The information given in this document is correct to the best of our knowledge and experience at the time of publication. If not expressly agreed otherwise, this information does not represent a warranty in the legal sense of the word. As the state of our knowledge and experience is constantly changing, the information in this data sheet is subject to revision. We therefore kindly ask you to always use the latest issue of this document (available under www.pepperl-fuchs.com).

No part of this document may be reproduced or utilized in any form without our prior permission in writing.

2 Terminology and Abbreviations

PE and \oplus symbol	PE is the abbreviation for P rotective E arth and has the same meaning as the symbol \oplus .
Earth, Ground	This document uses the term earth which is the same as the U.S. term ground .
T.b.d.	To be defined, value or description will follow later.
DC 24V	A figure displayed with the AC or DC before the value represents a nominal voltage with standard tolerances included. E.g.: DC 12V describes a 12V battery disregarding whether it is full (13.7V) or flat (10V)
24Vdc	A figure with the unit (Vdc) at the end is a momentary figure without any additional tolerances included.
may	A key word indicating flexibility of choice with no implied preference.
shall	A key word indicating a mandatory requirement.
should	A key word indicating flexibility of choice with a strongly preferred implementation.

3 Intended Use

This device is designed for installation in an enclosure and is intended for the general professional use such as in industrial control, office, communication, and instrumentation equipment.

Do not use this power supply in equipment, where malfunction may cause severe personal injury or threaten human life.

Function

The device provides a stable, galvanically isolated SELV/PELV output voltage of 24 V DC.

The device has a power reserve of 20 % included, which may even be used continuously at temperatures up to +45 °C.

A reverse polarity protection prevents damage to the device caused by faulty wiring.

The output voltage can be adjusted via a potentiometer. The device status is indicated by an LED.

The device is mounted on a 35 mm DIN mounting rail according to EN 60715.

Reference Conditions

All values are typical figures specified at 24Vdc input voltage 24V, 10A output load, 25°C ambient and after a 5 minutes run-in time unless otherwise noted.

4 Installation Instructions



Warning!

Risk of electrical shock, fire, personal injury or death.

- Turn power off before working on the device. Protect against inadvertent re-powering.
- Do not modify or repair the unit.
- Do not open the unit as high voltages may present inside.
- Use caution to prevent any foreign objects from entering the housing.
- Do not use in wet locations or in areas where moisture or condensation can be expected.
- Do not touch during power-on, and immediately after power-off.
Hot surface may cause burns.



Note

Observe the safety information in the instruction manual and in chapter 20.

This device may only be installed and put into operation by qualified personnel.

This device does not contain serviceable parts. The tripping of an internal fuse is caused by an internal defect.

If damage or malfunction should occur during installation or operation, immediately turn power off and send unit to the factory for inspection.

Install device in an enclosure providing protection against electrical, mechanical and fire hazards.

Install the device onto a DIN-rail according to EN 60715 with the input terminals on the bottom of the device. Other mounting orientations require a reduction in output current.

Make sure that the wiring is correct by following all local and national codes.

Use appropriate copper cables that are designed for a minimum operating temperature of 60°C for ambient temperatures up to +45°C, 75°C for ambient temperatures up to +60°C and 90°C for ambient temperatures up to +70°C. Ensure that all strands of a stranded wire enter the terminal connection.

Unused screw terminals should be securely tightened.

The device is designed for pollution degree 2 areas in controlled environments.
No condensation or frost allowed.

The enclosure of the device provides a degree of protection of IP20.

The input can be powered from batteries or similar DC sources. The voltage between the input terminals and ground must not exceed 60Vdc continuously. The ripple voltage in the low frequency range between 50Hz and 10kHz must be negligible when used in marine applications.

The input must be powered from a PELV or SELV source or an **Isolated Secondary Circuit** in order to maintain a SELV or PELV output.

Check for correct input polarity. The device will not operate when the voltage is reversed.

A disconnecting means shall be provided for the input of the device.

The device is designed as **Class of Protection III** equipment according to IEC 61140.

A PE (ground) connection is not required. However, connecting the chassis ground terminal to ground can be beneficial to gain a high EMI immunity.

The device is designed for convection cooling and does not require an external fan.
Do not obstruct airflow and do not cover ventilation grid!

The device is designed for altitudes up to 6000m (19685ft). See additional requirements in this document for use above 2000m (6560ft).

Keep the following minimum installation clearances: 40mm on top, 20mm on the bottom, 5mm left and right side. Increase the 5mm to 15mm in case the adjacent device is a heat source. When the device is permanently loaded with less than 50%, the 5mm can be reduced to zero.

The device is designed, tested and approved for branch circuits up to 50A without additional protection device. If an external fuse is utilized, do not use circuit breakers smaller than 20A B- or C-Characteristic to avoid a nuisance tripping of the circuit breaker.

The maximum surrounding air temperature is +70°C (+158°F). The operational temperature is the same as the ambient or surrounding air temperature and is defined 2cm below the device.

The device is designed to operate in areas between 5% and 95% relative humidity.

5 DC Input

The input can be powered from batteries or similar DC sources and must be a PELV or SELV source or an **Isolated Secondary Circuit** in order to maintain a SELV or PELV output.

Check for correct input polarity. The device will not operate when the voltage is reversed.

DC input	Nom.	DC 24V	-25%/+46%
DC input range	Min.	18.0-35.0Vdc	Continuous operation
Allowed voltage between input and earth/ground	Max.	60Vdc or 42.2Vac	Continuous operation, according to IEC 62477-1
Allowed input ripple voltage	Max.	5Vpp	In the frequency range from 47 to 500Hz, the momentary input voltage must always be within the specified limits.
Turn-on voltage	Typ.	17.5Vdc	Steady-state value, see Figure 5.1.
Shut-down voltage	Typ.	15.5Vdc	Steady-state value, see Figure 5.1.
Input current	Typ.	10.5A	At 24Vdc input and 24V, 10A output load, see Figure 5.3.
	Typ.	14.3A	At 18Vdc input and 24V, 10A output load, see Figure 5.3.
Start-up delay	Typ.	200ms	See Figure 5.1.
Rise time	Typ.	200ms	At 24V, 10A constant current load, 0mF load capacitance, see Figure 5.2.
	Typ.	200ms	At 24V, 10A constant current load, 10mF load capacitance, see Figure 5.2
Turn-on overshoot	Max.	250mV	See Figure 5.2.
Input capacitance	Typ.	4 300 μ F	Installed inside the device, external capacitors on the input are allowed without any limitations.
External input protection	See recommendations in chapter 4.		

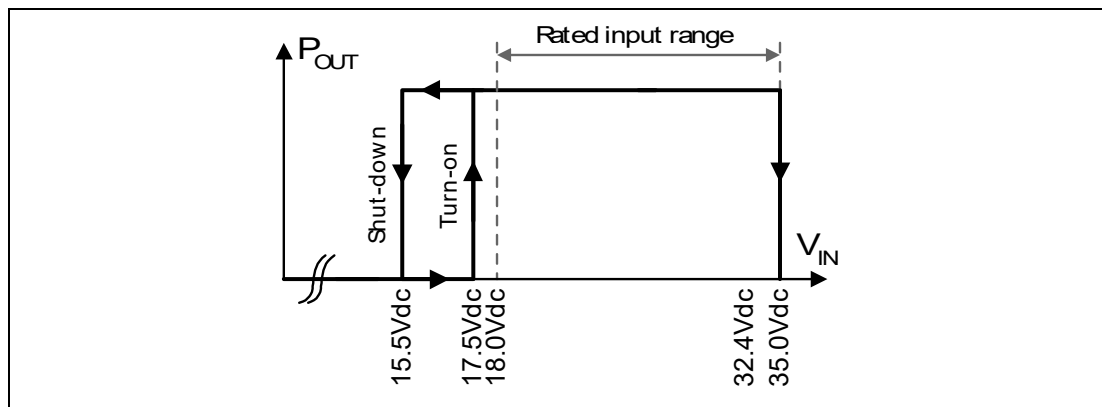

Figure 5.1 Input voltage range

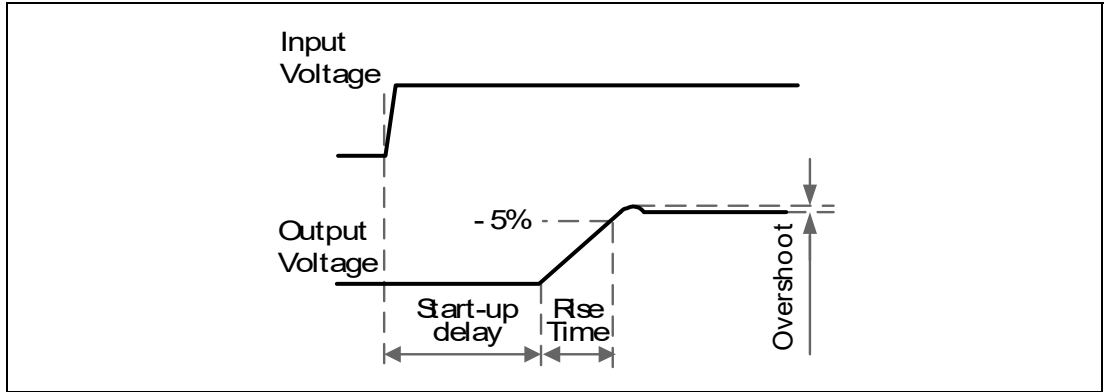

Figure 5.2 Turn-on behavior, definitions

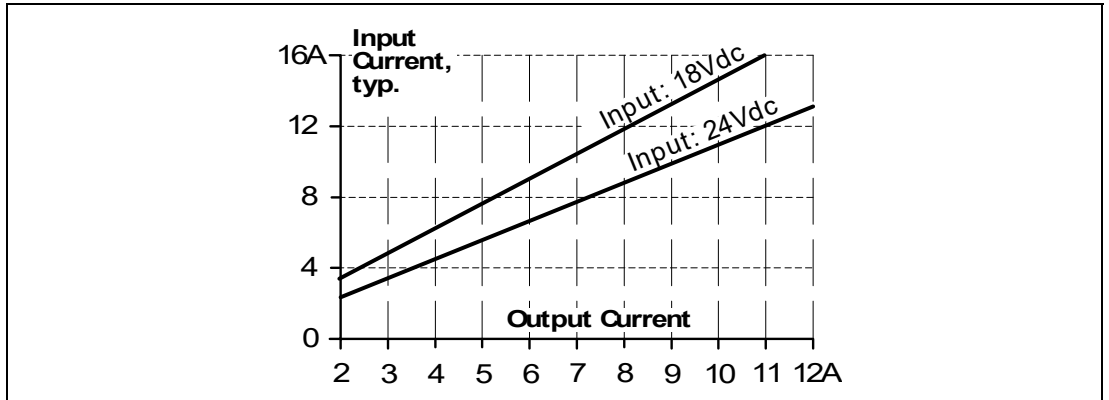

Figure 5.3 Input current vs. output load

Requirements for the Supplying Source

In certain circumstances, the input filter of the DC/DC converter can show a resonant effect which is caused by the supplying network. Especially when additional external input filters are utilized, a superimposed AC voltage can be generated on the input terminals of the DC/DC converter which might cause a malfunction of the unit. Therefore, additional input filters are not recommended. To avoid the resonant effects, the minimal resistance of the supplying network which depends on the inductance of the input network, shall be above the boundary curve in Figure 5.4.

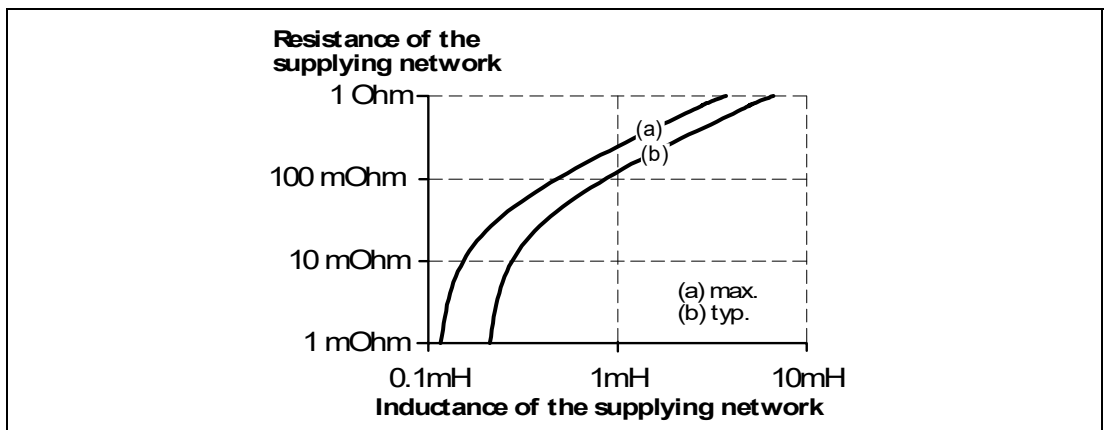

Figure 5.4 External input filter requirements to avoid filter instabilities

6 Input Inrush Current

An active inrush limitation circuit (inrush limiting NTC resistor which is bypassed by a MOSFET) limits the input inrush current after turn-on of the input voltage.

The charging current into EMI suppression capacitors is disregarded in the first microseconds after switch-on.

Inrush current	Max.	8A	At +25°C ambient, cold start
	Max.	25A	At +60°C ambient, cold start
	Typ.	6A _{peak}	At +25°C ambient, cold start
	Typ.	22A _{peak}	At +60°C ambient, cold start
Inrush energy	Max.	1A ² s	Between -25°C to +70°C, cold start

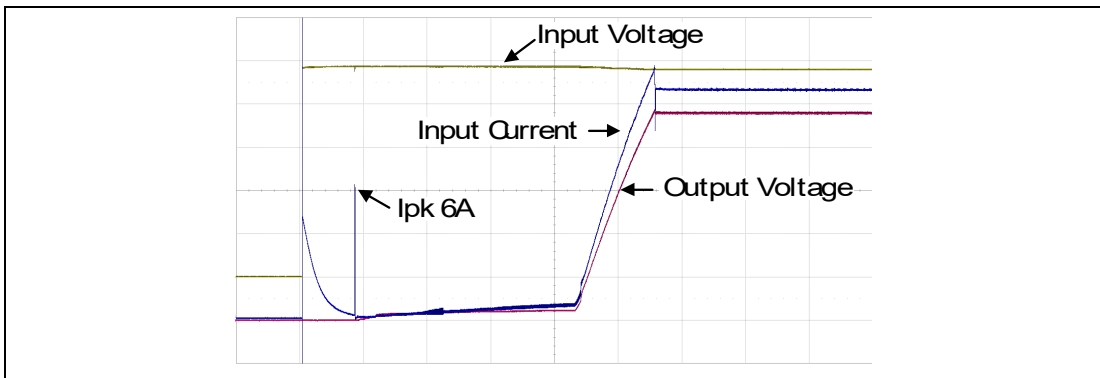

Figure 6.1 Typical input inrush current behavior at nominal load and 25°C ambient

Input	24Vdc
Output	24V, 10A, constant current load
Ambient	25°C
Input current	2A/DIV
Input voltage	5V/DIV
Output voltage	5V/DIV
Time basis	100ms/DIV

7 Soft-Start Feature

After the DC/DC converter is turned on, the internal output current rises slowly to its nominal value. This method charges the output capacitors (internal and external capacitors) slowly and avoids high input currents during turn-on.

High input currents can produce a high voltage drop on the input wiring (especially with long and thin cables) which reduces the terminal voltage on the DC/DC converter. If the terminal voltage is below the shut-down voltage, the DC/DC converter will turn-off and will make a new start-up attempt. This effect is avoided with the integrated soft-start function.



Note

This function increases the rise time of the output voltage by a small amount.

8 Output

The output provides a SELV/PELV rated voltage, which is galvanically isolated from the input voltage and is designed to supply any kind of loads, including unlimited capacitive and inductive loads.

The output is electronically protected against overload, no-load and short-circuits. In case of a protection event, audible noise may occur.

Output voltage	Nom.	24V	
Adjustment range	Min.	24-28V	Guaranteed value from 23-28V
	Max.	30V	This is the maximum output voltage which can occur at the clockwise end position of the potentiometer due to tolerances. It is not a guaranteed value which can be achieved.
Factory setting		24.1V	±0.2%, at full load, cold unit
Line regulation	Max.	25mV	Between 18 and 35Vdc input voltage variation
Load regulation	Max.	100mV	Between 0 and 10A load variation, static value
Ripple and noise voltage	Max.	50mVpp	Bandwidth 20Hz to 20MHz, 50Ohm
Output current	Nom.	12A	At 24V and an ambient temperature below +45°C
	Nom.	10A	At 24V and +60° ambient temperature
	Nom.	7.5A	At 24V and +70° ambient temperature
	Nom.	10.3A	At 28V and an ambient temperature below +45°
	Nom.	8.6A	At 28V and +60° ambient temperature
	Nom.	6.5A	At 28V and +70° ambient temperature
Overload behavior		Continuous current	
Overload/ short-circuit current	Max.	15A	Continuous current
Output capacitance	Typ.	4 500µF	Included inside the power supply
Back-feeding loads	Max.	35V	The unit is resistant and does not show malfunctioning when a load feeds back voltage to the power supply. It does not matter whether the power supply is on or off. The absorbing energy can be calculated according to the built-in large sized output capacitor.

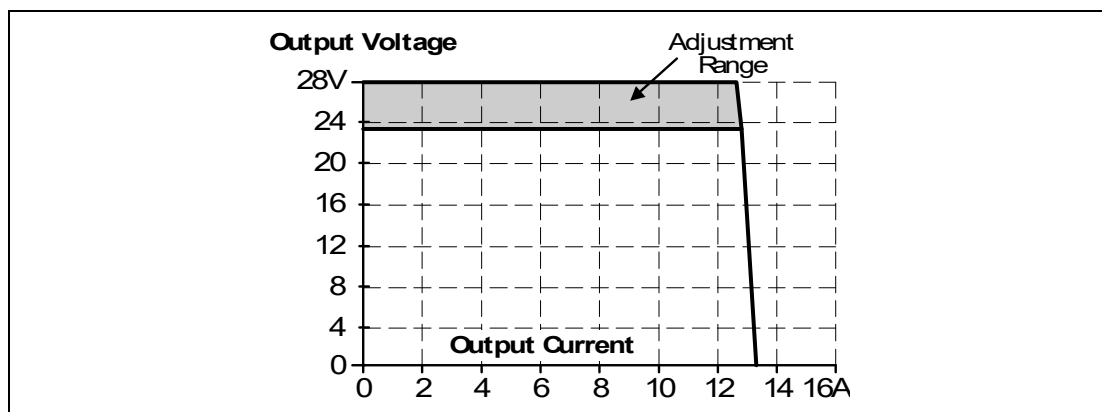

Figure 8.1 Output voltage vs. output current at 24Vdc input voltage, typ.

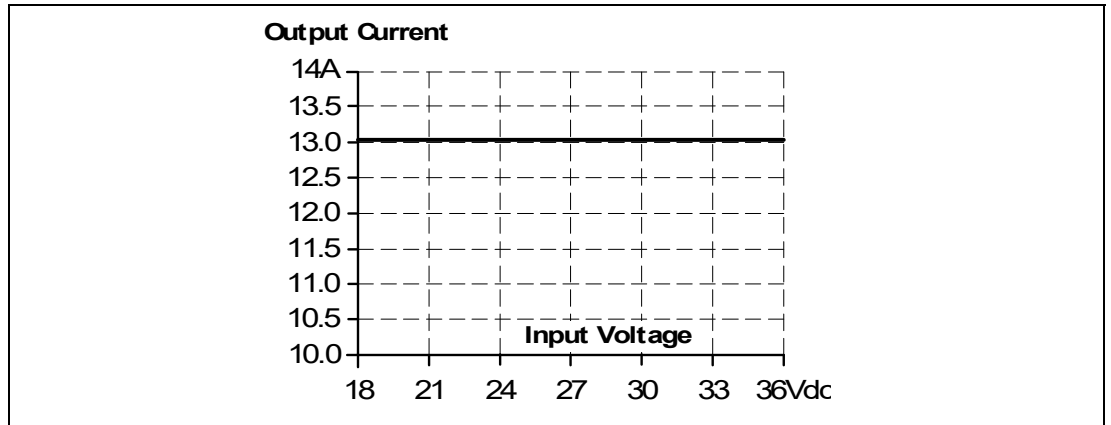

Figure 8.2 Current limitation vs. input voltage, (23V constant voltage load), typ.

9 Hold-Up Time

The input side of the DC/DC converter is equipped with a bulk capacitor which keeps the output voltage alive for a certain period of time when the input voltage dips or is removed. The bulk capacitor can be discharged by loading the DC/DC converter on the output side or through a load which is parallel to the input. There is no protection in the DC/DC converter which prevents current from flowing back to the input terminals. If prevention is needed, an external diode should be used.

At no load, the hold-up time can be up to several seconds. The green DC-ok lamp is also on during this time.

Hold-up Time	Typ.	8ms	At 24Vdc input voltage, 24V, 5A output, see Figure 9.1
	Min..	6.5ms	At 24Vdc input voltage, 24V, 5A output, see Figure 9.1
	Typ.	4ms	At 24Vdc input voltage, 24V, 10A output, see Figure 9.1
	Min..	3.2ms	At 24Vdc input voltage, 24V, 10A output, see Figure 9.1

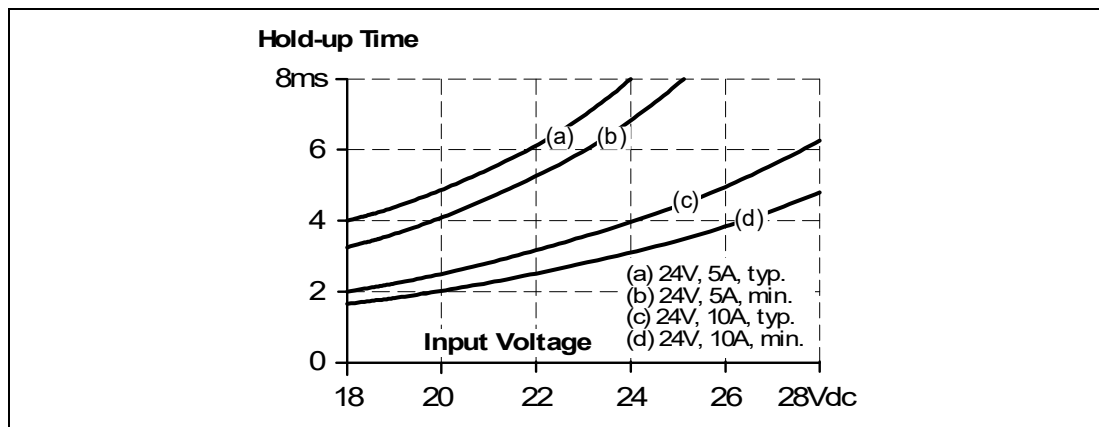

Figure 9.1 Hold-up time vs. input voltage

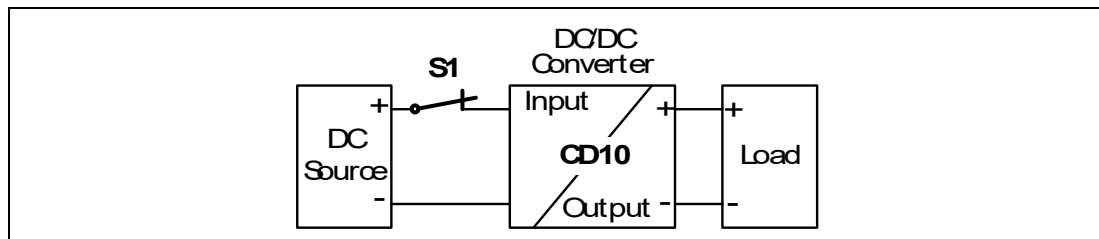

Figure 9.2 Shut-down test setup

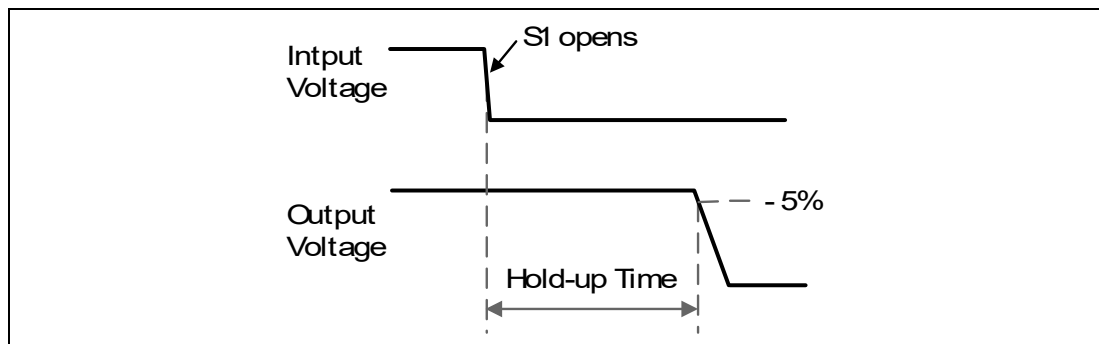

Figure 9.3 Shut-down behavior, definitions

10 Efficiency and Power Losses

Input 24Vdc			
Efficiency	Typ.	94.2%	At 24V, 10A
	Typ.	93.7%	At 24V, 12A (Power Boost)
Average efficiency ¹	Typ.	94.3%	At 25% at 2.5A, 25% at 5A, 25% at 7.5A. 25% at 10A
Power losses	Typ.	1.75W	At no output load
	Typ.	6.8W	At 24V, 5A
	Typ.	14.7W	At 24V, 10A
	Typ.	19.5W	At 24V, 12A

¹ The average efficiency is an assumption for a typical application where the power supply is loaded with 25% of the nominal load for 25% of the time, 50% of the nominal load for another 25% of the time, 75% of the nominal load for another 25% of the time and with 100% of the nominal load for the rest of the time.

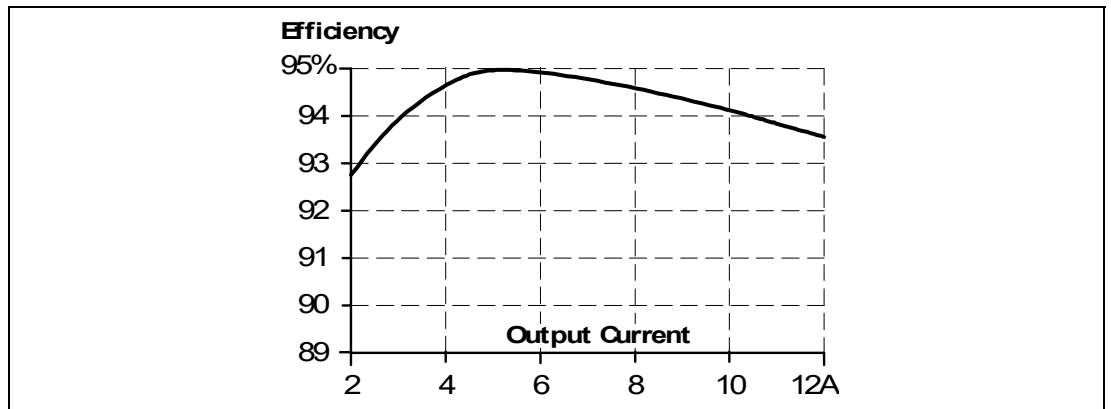

Figure 10.1 Efficiency vs. output current at 24V output and 24Vdc input voltage, typ.

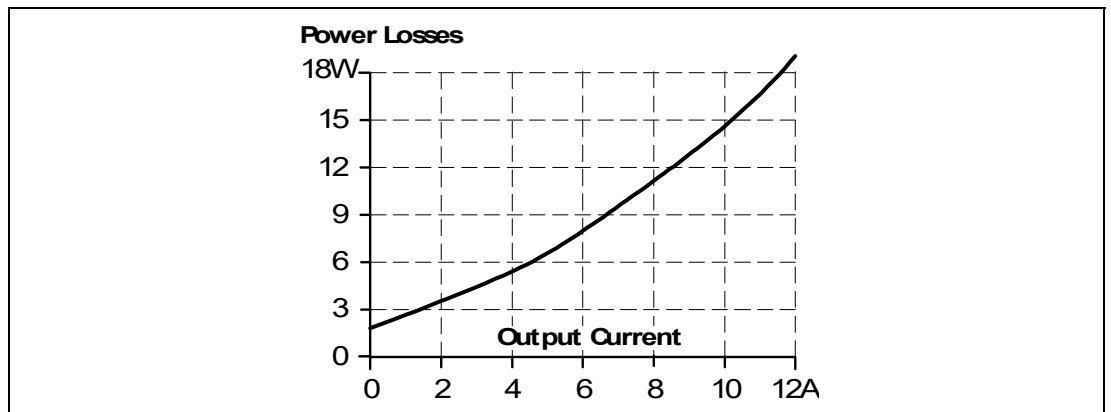

Figure 10.2 Losses vs. output current at 24V output and 24Vdc input voltage, typ.

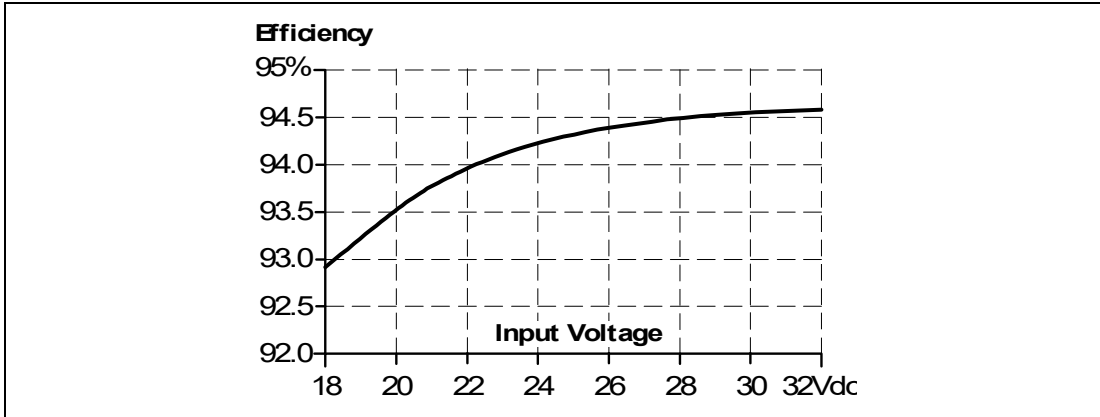

Figure 10.3 Efficiency vs. input voltage at 24V, 10A, typ.

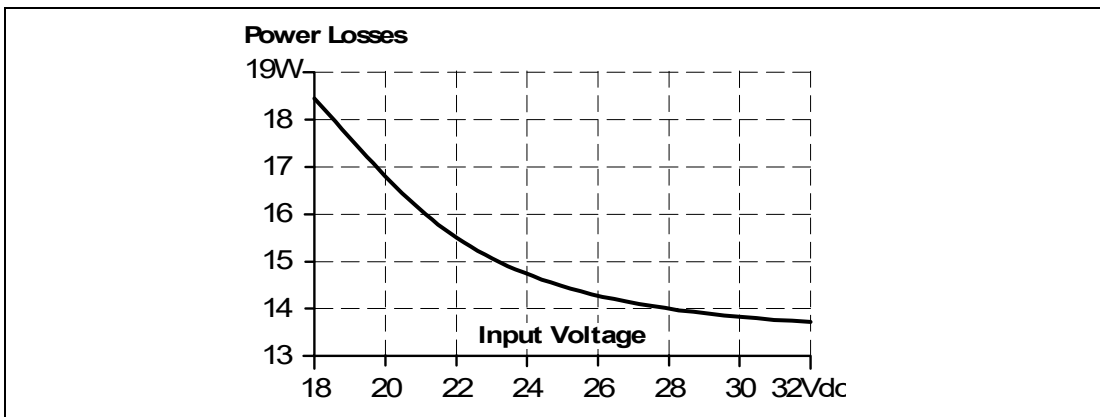

Figure 10.4 Losses vs. input voltage at 24V, 10A, typ.

11 Functional Diagram

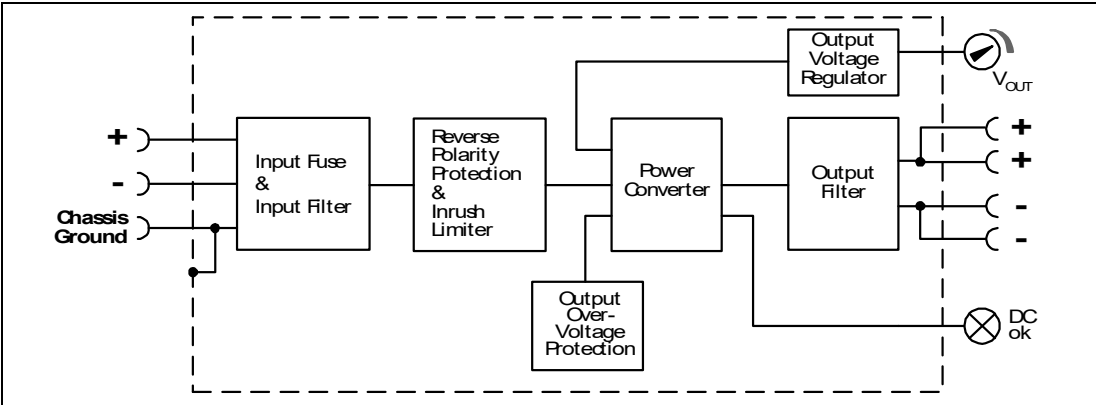

Figure 11.1 Functional diagram

12 Front Side and User Elements

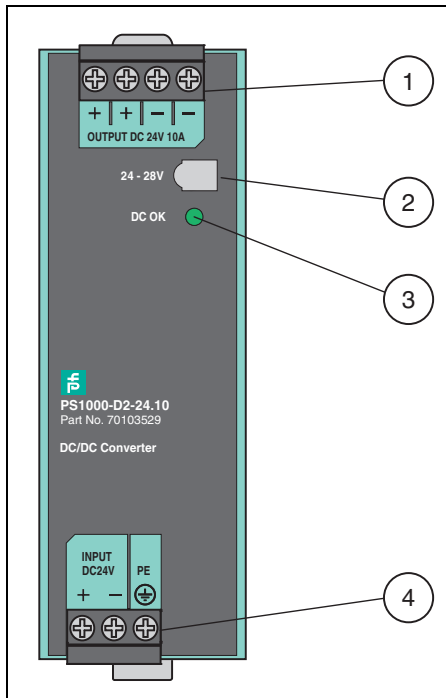

Figure 12.1 Front side

1 Output Terminals

Screw terminals, dual terminals per pole, both pins are equal
 + Positive output (two identical + poles)
 - Negative/return output (two identical - poles)

2 Output Voltage Potentiometer

Open the flap to adjust the output voltage.
 Factory set: 24.1V

3 DC-OK LED (green)

On when the voltage on the output terminals is > 21V

4 Input Terminals

+ Positive input
 - Negative/return input
 Chassis ground: to bond the housing to ground, PE or Functional Earth

13 Connection Terminals

The terminals are IP20 finger safe constructed and suitable for field- and factory wiring.

	Input	Output
Type	Screw termination	Screw termination
Solid wire	Max. 6mm ²	Max. 6mm ²
Stranded wire	Max. 4mm ²	Max. 4mm ²
American Wire Gauge	AWG 20-10	AWG 20-10
Max. wire diameter (including ferrules)	2.8mm	2.8mm
Recommended tightening torque	Max. 1Nm, 9lb-in	Max. 1Nm, 9lb-in
Wire stripping length	7mm / 0.28inch	7mm / 0.28inch
Screwdriver	3.5mm slotted or Phillips No 2	3.5mm slotted or Phillips No 1

Daisy chaining of outputs

Daisy chaining (jumping from one DC/DC-converter output to the next) is allowed as long as the average output current through one terminal pin does not exceed 25A. If the current is higher, use a separate distribution terminal block.

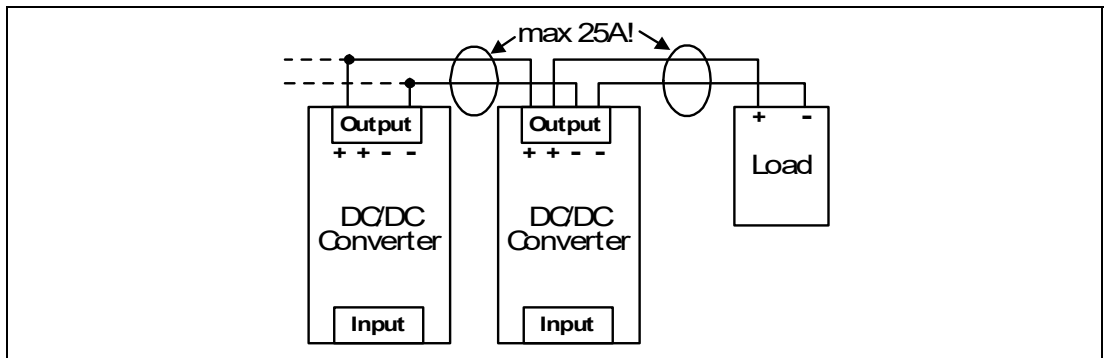

Figure 13.1 Daisy chaining of outputs

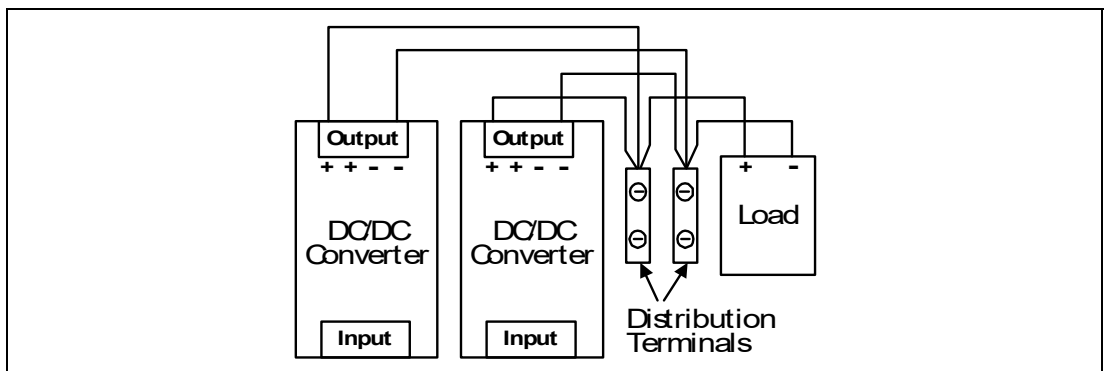

Figure 13.2 Using distribution terminals

14 Lifetime Expectancy

The Lifetime expectancy shown in the table indicates the minimum operating hours (service life) and is determined by the lifetime expectancy of the built-in electrolytic capacitors. Lifetime expectancy is specified in operational hours and is calculated according to the capacitor's manufacturer specification. The manufacturer of the electrolytic capacitors only guarantees a maximum life of up to 15 years (131 400h). Any number exceeding this value is a calculated theoretical lifetime which can be used to compare devices.

	Input 24Vdc	
Lifetime expectancy	299 000h	at 24V, 5A and 40°C
	103 000h	at 24V, 10A and 40°C
	56 000h	at 24V, 12A and 40°C
	844 000h	at 24V, 5A and 25°C
	292 000h	at 24V, 10A and 25°C
	159 000h	at 24V, 12A and 25°C

15 MTBF

MTBF stands for **Mean Time Between Failure**, which is calculated according to statistical device failures, and indicates reliability of a device. It is the statistical representation of the likelihood of a unit to fail and does not necessarily represent the life of a product.

The MTBF figure is a statistical representation of the likelihood of a device to fail. A MTBF figure of e.g. 1 000 000h means that statistically one unit will fail every 100 hours if 10 000 units are installed in the field. However, it can not be determined if the failed unit has been running for 50 000h or only for 100h.

For these types of units the **MTTF (Mean Time To Failure)** value is the same value as the MTBF value.

	Input 24Vdc	
MTBF SN 29500, IEC 61709	731 000h	At 24V, 10A and 40°C
	1 321 000h	At 24V, 10A and 25°C
MTBF MIL HDBK 217F	358 000h	At 10A and 40°C; Ground Benign GB40
	556 000h	At 10A and 25°C; Ground Benign GB25
	731 000h	At 10A and 40°C; Ground Fixed GF40
	142 000h	At 10A and 25°C; Ground Fixed GF25

16 EMC

The EMC behavior of the device is designed for applications in industrial environment as well as in residential, commercial and light industry environments.

The device is investigated according to the generic standards EN 61000-6-1, EN 61000-6-2, EN 61000-6-3 and EN 61000-6-4.

EMC Immunity

Electrostatic discharge	EN 61000-4-2	Contact discharge Air discharge	8kV 15kV	Criterion A Criterion A
Electromagnetic RF field	EN 61000-4-3	80MHz-2.7GHz	20V/m	Criterion A
Fast transients (Burst)	EN 61000-4-4	Input lines Output lines	4kV 2kV	Criterion A Criterion A
Surge voltage on input	EN 61000-4-5	+ → -	1kV	Criterion A
		+/- → chassis ground	2kV	Criterion A
Surge voltage on output	EN 61000-4-5	+ → -	500V	Criterion A
		+/- → chassis ground	1kV	Criterion A
Conducted disturbance	EN 61000-4-6	0.15-80MHz	20V	Criterion A

Criterion A The device shows normal operation behavior within the defined limits.

Criterion C Temporary loss of function is possible. Power supply may shut-down and restarts by itself. No damage or hazards for the power supply will occur.

EMC Emission

Conducted emission on input lines	IEC/CISPR 16-1-2, IEC/CISPR 16-2-1	Limits for DC power networks according to EN 61000-6-3 fulfilled
Conducted emission on output lines	IEC/CISPR 16-1-2, IEC/CISPR 16-2-1	T.b.d.
Radiated emission	EN 55011, EN 55022	Class B

This device complies with FCC Part 15 rules.

Operation is subjected to following two conditions: (1) this device may not cause harmful interference, and (2) this device must accept any interference received, including interference that may cause undesired operation.

Switching Frequency

Main converter	50kHz to 300kHz	Output load and input voltage dependent
----------------	-----------------	---

17 Environment

Operational temperature	-25°C to +70°C (-13°F to 158°F)	The operational temperature is the ambient or surrounding temperature and is defined as the air temperature 2cm below the device.
Storage temperature	-40°C to +85°C (-40°F to 185°F)	For storage and transportation
Output de-rating	3.2W/°C 6W/°C 15W/1000m or 5°C/1000m 9W/-5kPa or 3°C/-5kPa	Between +45°C and +60°C (113°F to 140°F) Between +60°C and +70°C (140°F to 158°F) For altitudes >2000m (6560ft), see Figure 17.2 For atmospheric pressures <80kPa, see Figure 17.2 The de-rating is not hardware controlled. The customer has to take care by himself to stay below the de-rated current limits in order not to overload the unit.
Humidity	5 to 95% r.h.	According to IEC 60068-2-30
Atmospheric pressure	110-47kPa	See Figure 17.2 for details.
Altitude	Up to 6000m (20 000ft)	See Figure 17.2 for details.
Degree of pollution	2	According to IEC 62477-1, not conductive
Vibration sinusoidal	2-17.8Hz: ±1.6mm; 17.8-500Hz: 2g 2 hours / axis	According to IEC 60068-2-6
Shock	30g 6ms, 20g 11ms 3 bumps / direction, 18 bumps in total	According to IEC 60068-2-27 Shock and vibration is tested in combination with DIN-Rails according to EN 60715 with a height of 15mm and a thickness of 1.3mm and standard orientation.
LABS compatibility	As a rule, only non-silicon precipitating materials are used. The unit conforms to the LABS criteria and is suitable for use in paint shops.	
Corrosive gases	Tested according to ISA-71.04-1985, Severity Level G3 and IEC 60068-2-60 Test Ke Method 4 for a service life of minimum 10years in these environments.	
Audible noise	Some audible noise may be emitted from the power supply during no load, overload or short circuit.	

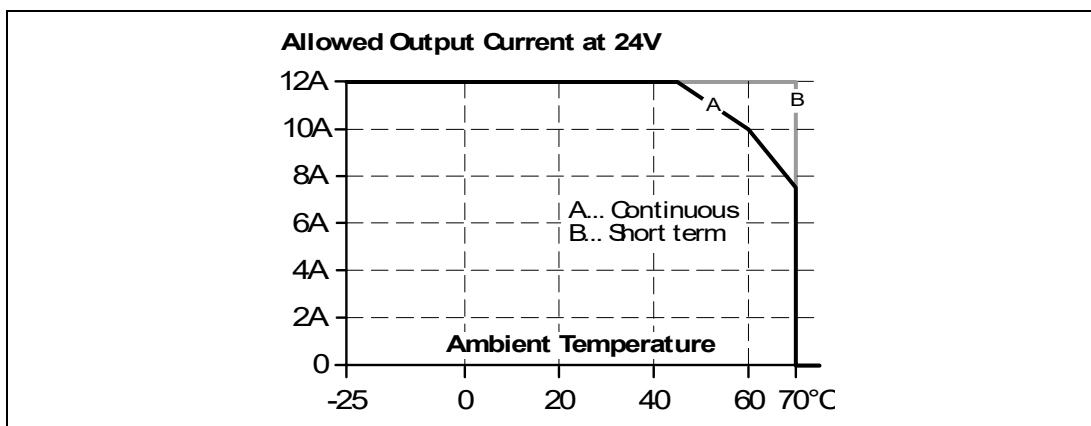

Figure 17.1 Output current vs. ambient temp.

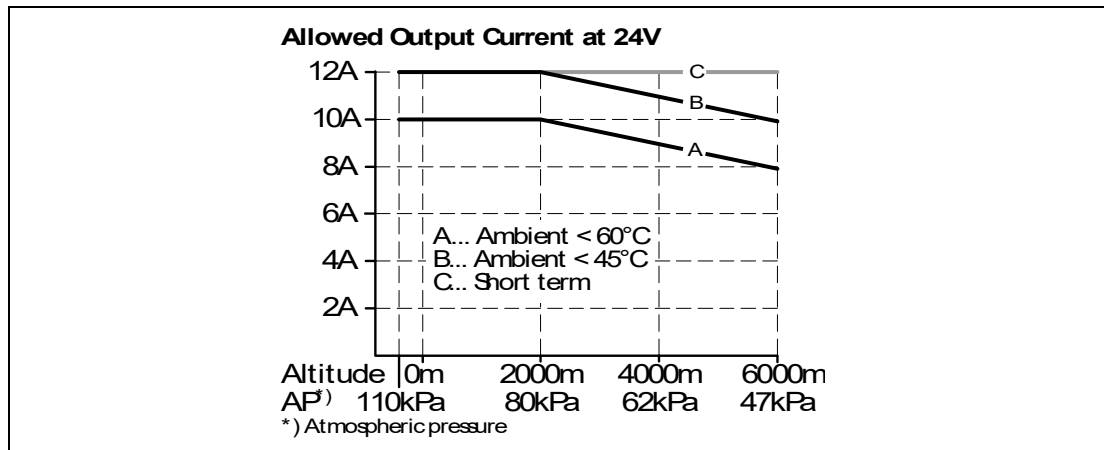

Figure 17.2 Output current vs. altitude

18 Safety and Protection Features

Isolation resistance	Min.	500M Ω	At delivered condition between input and output, measured with 500Vdc
	Min.	500M Ω	At delivered condition between input and Chassis Ground, measured with 500Vdc
	Min.	500M Ω	At delivered condition between output and Chassis Ground, measured with 500Vdc
PE resistance	Max.	0.1 Ω	Resistance between PE terminal and the housing in the area of the DIN-rail mounting bracket.
Output over-voltage protection	Typ.	31Vdc	In case of an internal defect, a redundant circuit limits the maximum output voltage. The output shuts down and automatically attempts to restart.
	Max.	32.5Vdc	
Class of protection		III	According to IEC 61140
Degree of protection		IP 20	According to EN/IEC 60529
Over-temperature protection		Not included	
Input transient protection		MOV (Metal Oxide Varistor)	For protection values see chapter 16 (EMC).
Internal input fuse		Included	Not user replaceable slow-blow high-braking capacity fuse
Touch current (leakage current)	The leakage current, which is produced by the DC/DC converter itself, depends on the input voltage ripple and need to be investigated in the final application. For a smooth DC input voltage, the produced leakage current is less than 100 μ A.		

19 Dielectric Strength

The output voltage is floating and has no ohmic connection to the ground.

The output is insulated to the input by a double or reinforced insulation.

Type and routine tests are conducted by the manufacturer. Field tests may be conducted in the field using the appropriate test equipment which applies the voltage with a slow ramp (2s up and 2s down). Connect all input-terminals together as well as all output poles before conducting the test. When testing, set the cut-off current settings to the value in the table below.

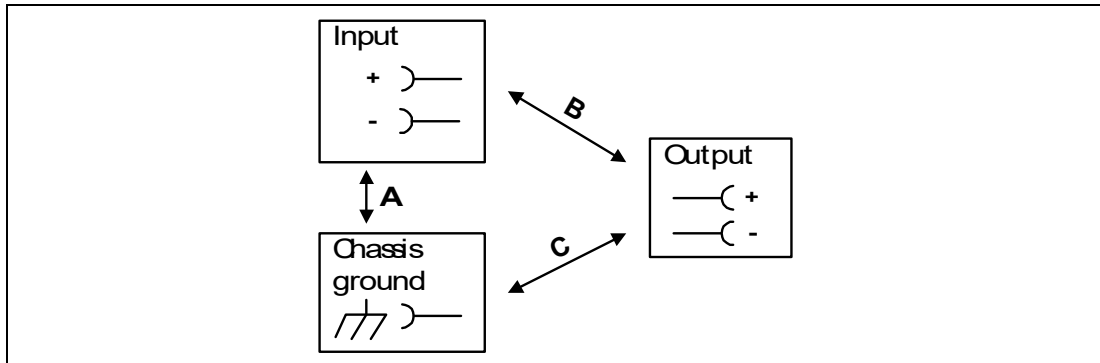

Figure 19.1 Dielectric strength

It is recommended that either the + pole, the – pole or any other part of the output circuit shall be connected to the earth/ground system. This helps to avoid situations in which a load starts unexpectedly or can not be switched off when unnoticed earth faults occur.

		A	B	C
Type test	60s	1500Vac	1500Vac	500Vac
Routine test	5s	1500Vac	1500Vac	500Vac
Field test	5s	1000Vac	1000Vac	500Vac
Cut-off current setting		40mA	20mA	12mA

20 Approvals

EU Declaration of Conformity



The CE mark indicates conformance with the European

- ATEX directive
- EMC directive
- Low-voltage directive (LVD)
- RoHS directive

UL 61010-2-201
(former UL 508)



UL Certificate

Listed equipment for category NMTR - UL 61010-2-201
Electrical Equipment for Measurement, Control and
Laboratory Use - Particular requirements for control
equipment
Applicable for US and Canada
E-File: E223176

EAC



EAC Certificate

EAC EurAsian Conformity Registration Russia,
Kazakhstan and Belarus

21 Other Fulfilled Standards

RoHS Directive	RoHS ✓	Directive 2011/65/EU of the European Parliament and the Council of June 8 th , 2011 on the restriction of the use of certain hazardous substances in electrical and electronic equipment.
REACH Directive	REACH ✓	Directive 1907/2006/EU of the European Parliament and the Council of June 1 st , 2007 regarding the Registration, Evaluation, Authorisation and Restriction of Chemicals (REACH)
IEC/EN 61558-2-16 (Annex BB)	Safety Isolating Transformer	Safety Isolating Transformers corresponding to Part 2-6 of the IEC/EN 61558

22 Physical Dimensions and Weight

Width	42mm, 1.65 inch
Height	124mm, 4.88 inch
Depth	117mm, 4.61 inch The DIN mounting rail height must be added to the unit depth to calculate the total required installation depth.
Weight	500g/1.1lb
DIN mounting rail	Use 35mm DIN mounting rails according to EN 60715 or EN 50022 with a height of 7.5 or 15mm.
Housing material	Body: Aluminium alloy Cover: zinc-plated steel
Installation instructions	See chapter 4.
Penetration protection	Small parts like screws, nuts, etc. with a diameter larger than 3.5mm

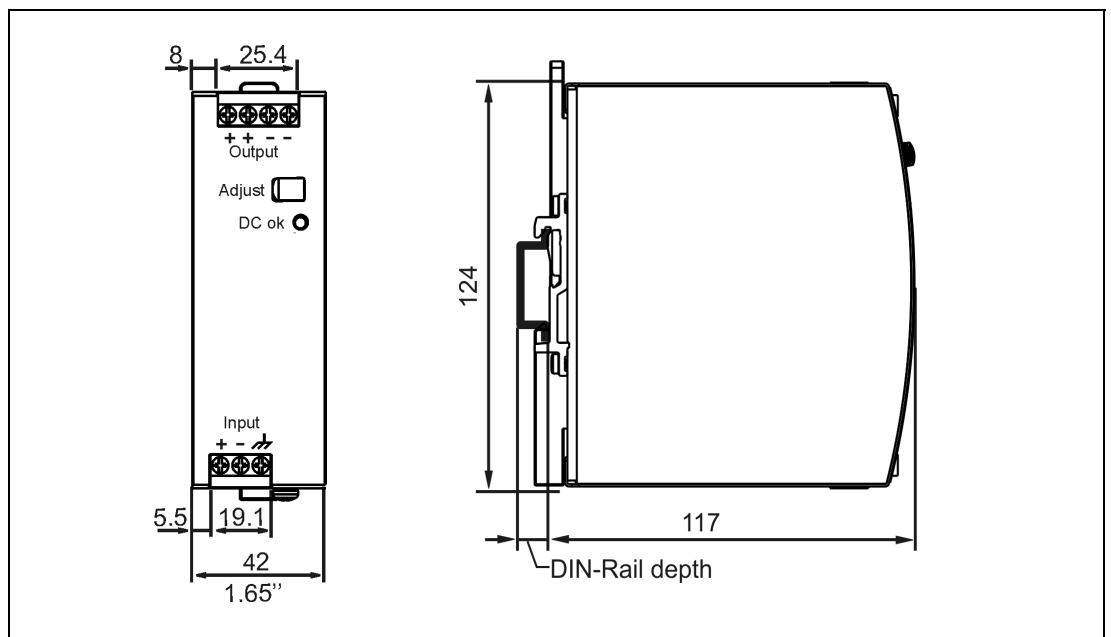

Figure 22.1 Device dimensions, all dimensions in mm

23 Application Notes

23.1 Peak Current Capability

The unit can deliver peak currents (up to several milliseconds) which are higher than the specified short term currents.

This helps to start current demanding loads. Solenoids, contactors and pneumatic modules often have a steady state coil and a pick-up coil. The inrush current demand of the pick-up coil is several times higher than the steady-state current and usually exceeds the nominal output current. The same situation applies when starting a capacitive load.

The peak current capability also ensures the safe operation of subsequent circuit breakers of load circuits. The load branches are often individually protected with circuit breakers or fuses. In case of a short or an overload in one branch circuit, the fuse or circuit breaker need a certain amount of over-current to open in a timely manner. This avoids voltage loss in adjacent circuits.

The extra current (peak current) is supplied by the power converter and the built-in large sized output capacitors of the power supply. The capacitors get discharged during such an event, which causes a voltage dip on the output. The following two examples show typical voltage dips:

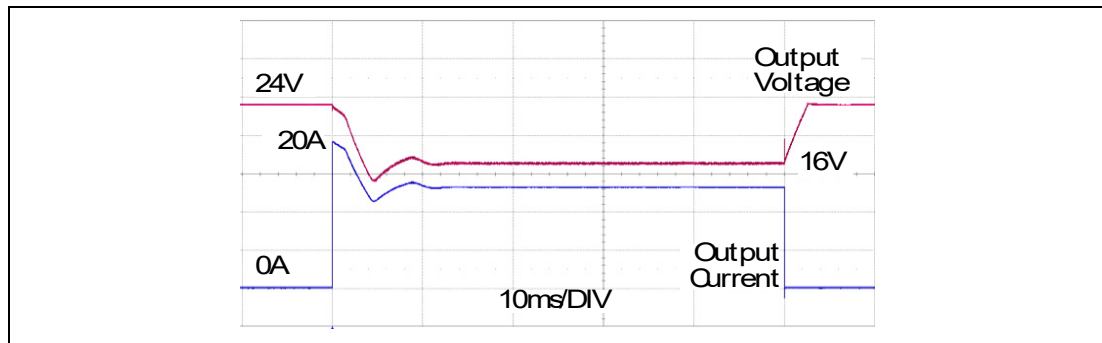

Figure 23.1 Peak loading with 2x the nominal current for 50ms, typ.
Peak load 20A (resistive load) for 50ms
Output voltage dips from 24V to 16V.

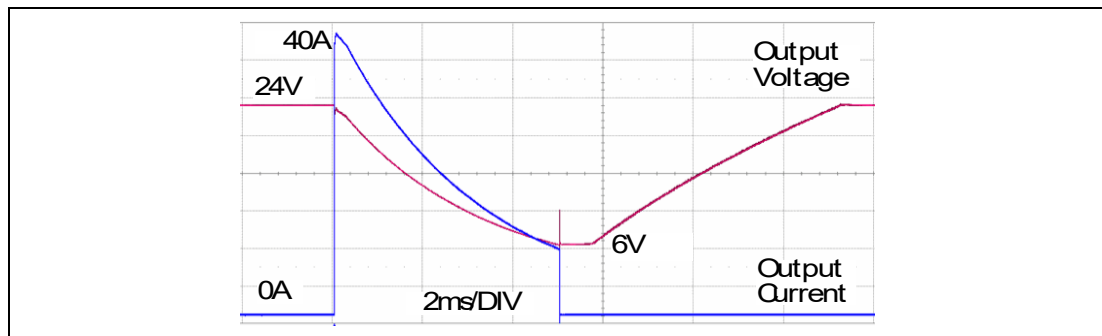

Figure 23.2 Peak loading with 4x the nominal current for 5ms, typ.
Peak load 40A (resistive load) for 5ms
Output voltage dips from 24V to 6V.

Peak current voltage dips	typ.	from 24V to 16V	at 20A for 50ms, resistive load
	typ.	from 24V to 12V	at 40A for 2ms, resistive load
	typ.	from 24V to 6V	at 40A for 5ms, resistive load

23.2 Output Circuit Breakers

Standard miniature circuit breakers (MCB's or UL 1077 circuit breakers) are commonly used for AC-supply systems and may also be used on 24V branches.

MCB's are designed to protect wires and circuits. If the ampere value and the characteristics of the MCB are adapted to the wire size that is used, the wiring is considered as thermally safe regardless of whether the MCB opens or not.

To avoid voltage dips and under-voltage situations in adjacent 24V branches which are supplied by the same source, a fast (magnetic) tripping of the MCB is desired.

A quick shutdown within 10ms is necessary corresponding roughly to the ride-through time of PLC's. This requires power supplies with high current reserves and large output capacitors. Furthermore, the impedance of the faulty branch must be sufficiently small in order for the current to actually flow. The best current reserve in the power supply does not help if Ohm's law does not permit current flow. The following table has typical test results showing which B- and C-Characteristic MCBs magnetically trip depending on the wire cross section and wire length.

The following test results indicate the maximal wire length for a magnetic (fast) tripping. The wire length is always two times the distance to the load (+ and - wire).

Test results for maximum wire length:

	0.75mm ²	1.0mm ²	1.5mm ²	2.5mm ²
C-2A	23 m	25 m	41 m	71 m
C-3A	13 m	15 m	23 m	33 m
C-4A	4 m	6 m	8 m	13 m
C-6A	1 m	2 m	2 m	5 m
B-6A	8 m	10 m	14 m	23 m
B-10A	1 m	2 m	2 m	3 m
B-13A	–	1 m	2 m	3 m

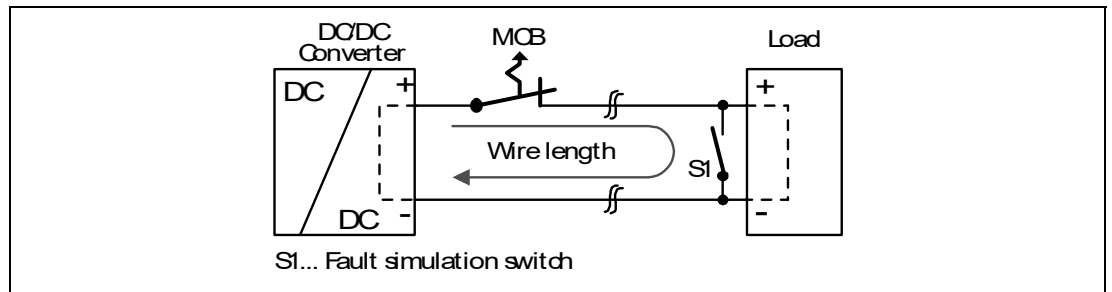

Figure 23.3 Test circuit

23.3 Charging of Batteries

The device can be used to charge lead-acid or maintenance free batteries. Two 12V SLA or VLRA batteries are needed in series connection.



Charging Batteries

1. Ensure that the ambient temperature of the Device is below 45°C, see table below.
2. Set output voltage, measured at no load and at the battery end of the cable, very precisely to the end-of-charge voltage.
3. Use a 16A circuit breaker or blocking diode between the device and the battery.
4. Ensure that the output current of the Device is below the allowed charging current of the battery.
5. Use only matched batteries when putting 12V types in series.
6. The return current to the Device (battery discharge current) is typ. 10mA when the device is switched off except in case a blocking diode is utilized.
7. Do not use the devices for battery charging in mounting orientations other than the standard mounting orientation or in any other condition where a reduction of the output current is required (e.g. altitude).

End-of-charge voltage	27.8V	27.5V	27.15V	26.8V
Battery temperature	10°C	20°C	30°C	40°C

23.4 Series Operation

Devices of the same type can be connected in series for higher output voltages. It is possible to connect as many units in series as needed, providing the sum of the output voltage does not exceed 150Vdc. Voltages with a potential above 60Vdc must be installed with a protection against touching.

Avoid return voltage (e.g. from a decelerating motor or battery) which is applied to the output terminals.

Restrictions

- Keep an installation clearance of 15mm (left / right) between two power supplies and avoid installing the power supplies on top of each other.
- Do not use power supplies in series in mounting orientations other than the standard mounting orientation.

Pay attention that EMI and inrush current will increase when using multiple devices.

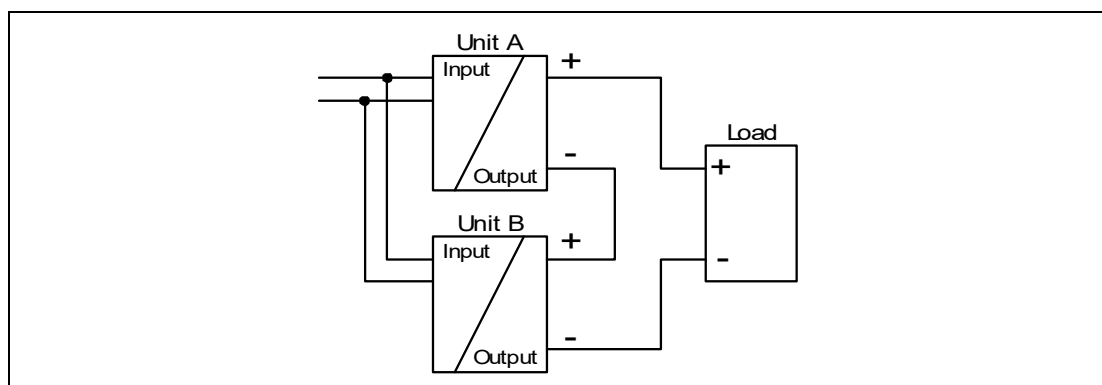

Figure 23.4 Series operation

23.5 Parallel Use to Increase Output Power

Devices can be paralleled to increase the output power. The output voltage shall be adjusted to the same value ($\pm 100\text{mV}$) with the same load conditions on all devices, or the devices can be left with the factory settings.

The ambient temperature is not allowed to exceed $+45^\circ\text{C}$.

If more than three devices are connected in parallel, a fuse or circuit breaker with a rating of 15A or 16A is required on each output. Alternatively, a diode or redundancy module can also be utilized.

Restrictions

- Keep an installation clearance of 15mm (left / right) between two devices and avoid installing devices on top of each other.
- Do not use devices in parallel in mounting orientations other than the standard mounting orientation or in any other condition where a reduction of the output current is required (e.g. altitude).

Pay attention that EMI and inrush current will increase when using multiple devices.

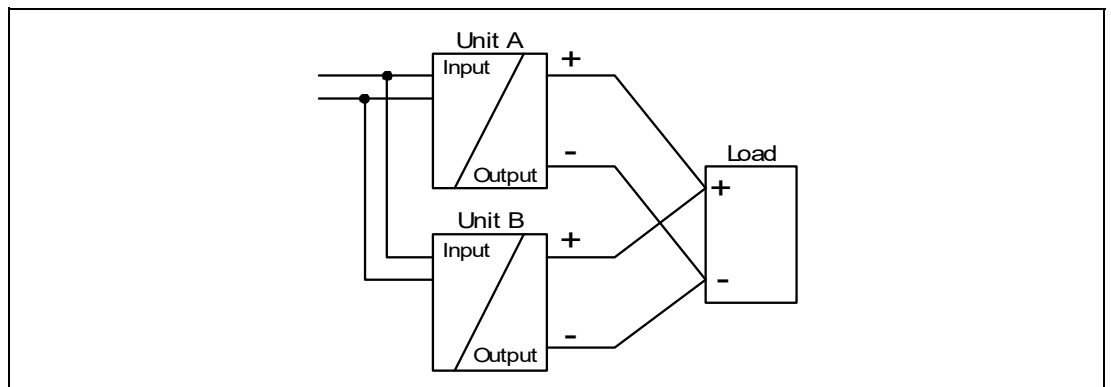

Figure 23.5 Parallel use to increase output power

23.6 Parallel Use for Redundancy

1+1 Redundancy

Devices can be paralleled for redundancy to gain higher system availability. Redundant systems require a certain amount of extra power to support the load in case one device fails. The simplest way is to put two devices in parallel. This is called a 1+1 redundancy. In case one device fails, the other one is automatically able to support the load current without any interruption. It is essential to use a redundancy module to decouple devices from each other. This prevents that the defective unit becomes a load for the other device and the output voltage cannot be maintained any more.

1+1 redundancy allows ambient temperatures up to +70°C.

Pay attention that EMI and inrush current will increase when using multiple devices.

Recommendations for building redundant power systems:

- Use separate input fuses for each device.
- Use separate supply systems for each device whenever it is possible.
- Monitor the outputs of the individual devices. Use the DC-OK lamp or the Redundancy-OK contact, which is included in the YR20.246 redundancy module.
- It is desirable to set the output voltages of all devices to the same value ($\pm 100\text{mV}$) or leave it at the factory setting.

N+1 Redundancy

Redundant systems for a higher power demand are usually built in a N+1 method. E.g. four devices, each rated for 10A are paralleled to build a 30A redundant system.

Pay attention that EMI and inrush current will increase when using multiple devices.

Restrictions

- Keep an installation clearance of 15mm (left / right) between two devices and avoid installing the devices on top of each other.
- Do not use devices in parallel in mounting orientations other than the standard mounting orientation or in any other condition, where a reduction of the output current is required.

For N+1 redundancy the ambient temperature is not allowed to exceed +45°C.

Wiring examples:

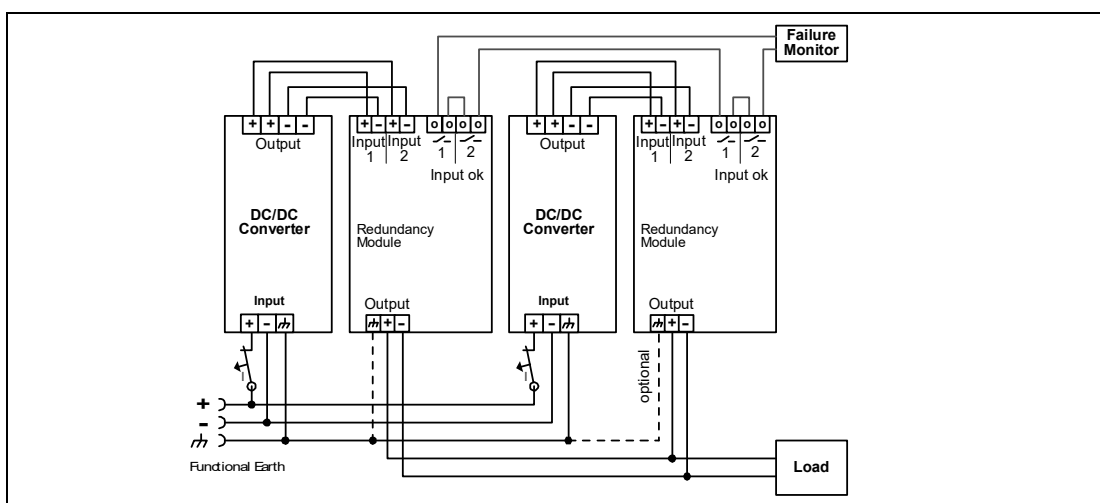

Figure 23.6 1+1 Redundant configuration for 10A load current

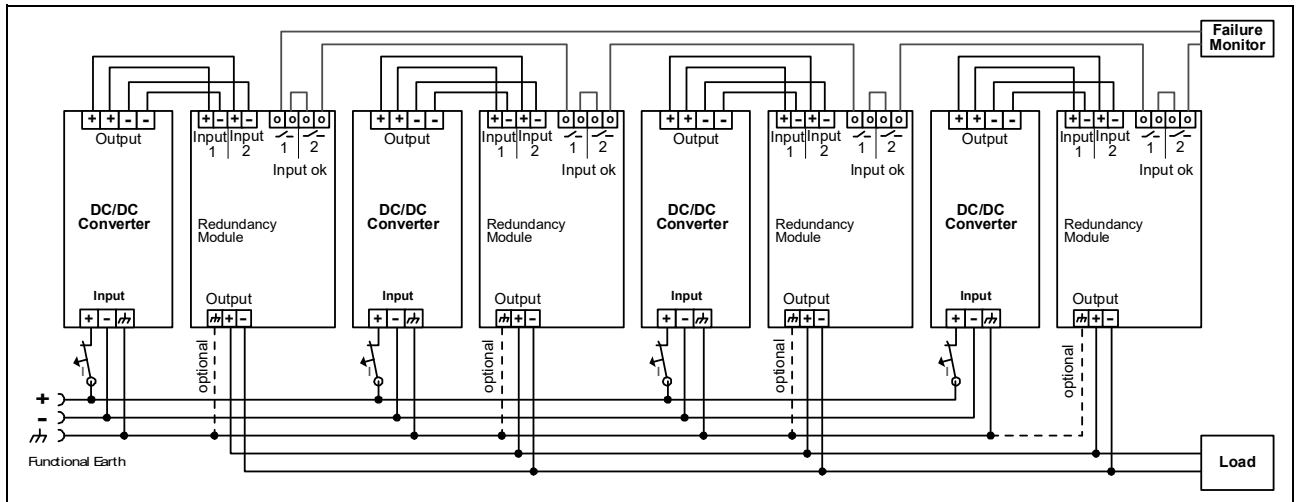

Figure 23.7 N+1 Redundant configuration for 30A load current with multiple DC/DC converters and redundancy modules

23.7 Use in a Tightly Sealed Enclosure

When the device is installed in a tightly sealed enclosure, the temperature inside the enclosure will be higher than outside. In such situations, the inside temperature defines the ambient temperature for the device.

In the following test setup, the device is placed in the middle of the enclosure; no other heat producing items are inside the enclosure. The load is placed outside the enclosure.

The temperature sensor inside the enclosure is placed in the middle of the right side of the device with a distance of 1cm.

The following measurement results can be used as a reference to estimate the temperature rise inside the enclosure.

	Case A	Case B
Enclosure size	110x180x165mm Rittal Typ IP66 Box PK 9516 100, plastic	110x180x165mm Rittal Typ IP66 Box PK 9516 100, plastic
Input voltage	24Vdc	24Vdc
Load	24V, 8A; (=80%)	24V, 10A; (=100%)
Temperature inside the box	52.2°C	59.3°C
Temperature outside the box	31.0°C	31.4°C
Temperature rise	21.2K	27.9K

23.8 Mounting Orientations

Mounting orientations other than input terminals on the bottom and output on the top require a reduction in continuous output power or a limitation in the maximum allowed ambient temperature.

The listed lifetime and MTBF values from this datasheet apply only for the standard mounting orientation.

The following curves give an indication for allowed output currents for altitudes up to 2000m (6560ft).

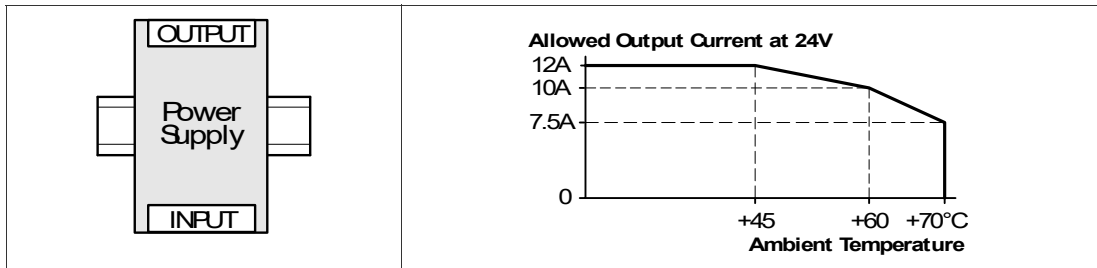

Figure 23.8 Mounting orientation A (standard orientation)

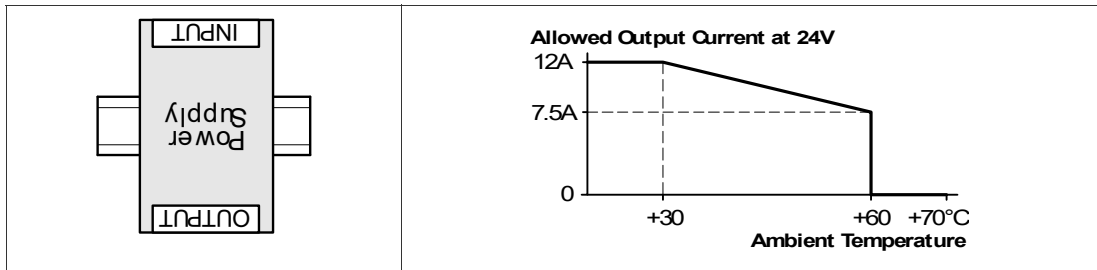

Figure 23.9 Mounting orientation B (upside down)

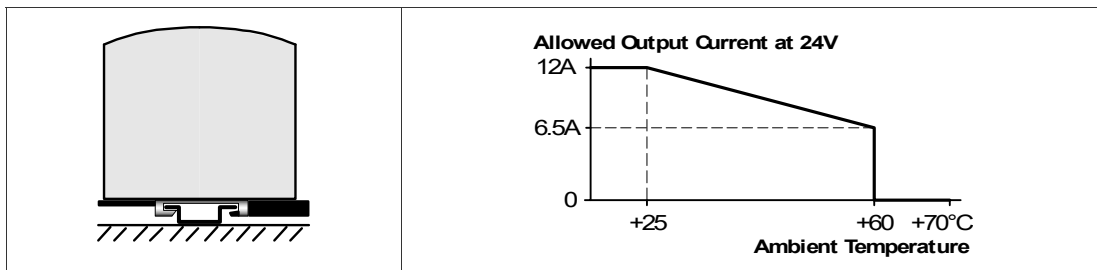

Figure 23.10 Mounting orientation C (table-top mounting)

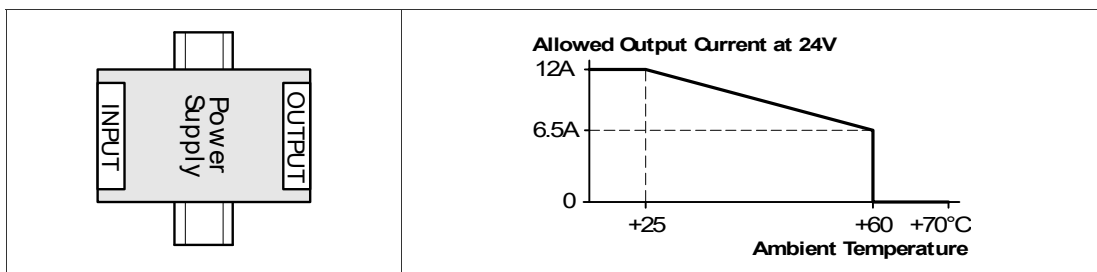

Figure 23.11 Mounting orientation D (horizontal cw)

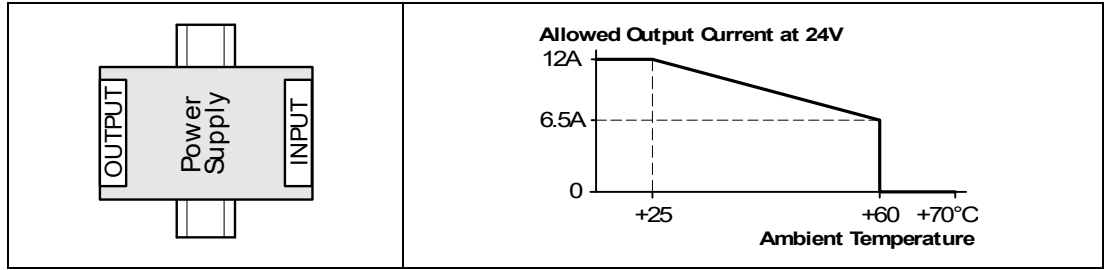

Figure 23.12 Mounting orientation E (horizontal ccw)

Your automation, our passion.

Explosion Protection

- Intrinsic Safety Barriers
- Signal Conditioners
- FieldConnex® Fieldbus
- Remote I/O Systems
- Electrical Ex Equipment
- Purge and Pressurization
- Industrial HMI
- Mobile Computing and Communications
- HART Interface Solutions
- Surge Protection
- Wireless Solutions
- Level Measurement

Industrial Sensors

- Proximity Sensors
- Photoelectric Sensors
- Industrial Vision
- Ultrasonic Sensors
- Rotary Encoders
- Positioning Systems
- Inclination and Acceleration Sensors
- Fieldbus Modules
- AS-Interface
- Identification Systems
- Displays and Signal Processing
- Connectivity

Pepperl+Fuchs Quality

Download our latest policy here:

www.pepperl-fuchs.com/quality

