

LVL-M3

Vibration Limit Switch

Brief Instructions

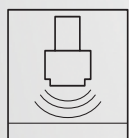
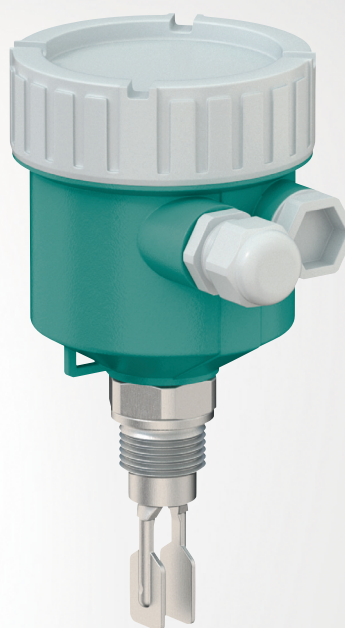

With regard to the supply of products, the current issue of the following document is applicable:
The General Terms of Delivery for Products and Services of the Electrical Industry, published by the Central Association of the Electrical Industry (Zentralverband Elektrotechnik und Elektroindustrie (ZVEI) e.V.) in its most recent version as well as the supplementary clause: "Expanded reservation of proprietorship"

Worldwide

Pepperl+Fuchs Group

Lilienthalstr. 200

68307 Mannheim

Germany

Phone: +49 621 776 - 0

E-mail: info@de.pepperl-fuchs.com

North American Headquarters

Pepperl+Fuchs Inc.

1600 Enterprise Parkway

Twinsburg, Ohio 44087

USA

Phone: +1 330 425-3555

E-mail: sales@us.pepperl-fuchs.com

Asia Headquarters

Pepperl+Fuchs Pte. Ltd.

P+F Building

18 Ayer Rajah Crescent

Singapore 139942

Phone: +65 6779-9091

E-mail: sales@sg.pepperl-fuchs.com

<https://www.pepperl-fuchs.com>

1	Introduction	5
1.1	Content of this Document	5
1.2	Safety Information	6
1.3	Symbols Used	6
2	Basic Safety Instructions	8
2.1	Requirements for Personnel	8
2.2	Designated Use	8
2.3	Workplace Safety	8
2.4	Operational Safety	9
2.5	Product Safety	9
3	Incoming Acceptance and Product Identification	10
3.1	Incoming Acceptance	10
3.2	Product Identification	10
3.3	Storage and Transport	11
4	Mounting	12
4.1	Mounting Requirements	13
4.2	Mounting the Device	16
4.3	Sliding Sleeves	18
4.4	Post-Installation Check	18
5	Electrical Connection	19
5.1	Connection Requirements	19
5.2	Connecting the Device	20
5.3	Post-Connection Check	26
6	Operation Options	27
6.1	Overview of Operation Options	27
7	Commissioning	28
7.1	Function Check	28
7.2	Switching on the Device	28
7.3	Further Information	28

1 Introduction

1.1 Content of this Document

This document contains information that you need in order to use your product throughout the applicable stages of the product life cycle. These can include the following:

- Product identification
- Delivery, transport, and storage
- Mounting and installation
- Commissioning and operation
- Maintenance and repair
- Troubleshooting
- Dismounting
- Disposal



Note

This document does not substitute the instruction manual.



Note

For full information on the product, refer to the instruction manual and further documentation on the Internet at www.pepperl-fuchs.com.



Note

For specific device information such as the year of construction, scan the QR code on the device. As an alternative, enter the serial number in the serial number search at www.pepperl-fuchs.com.

The documentation consists of the following parts:

- Datasheet – product overview
The datasheet contains the essential technical data for product selection.
- Technical information (TI) – planning aid
The document contains all the technical data on the device and provides an overview of the accessories and other products that can be ordered for the device.
- Manual (BA) – complete information
The manual contains all information from incoming acceptance to disposal.
- Brief instructions (KA), present document – guide that takes you quickly to the 1st measured value
The brief instructions contain all the essential information from incoming acceptance to initial commissioning.
- Instruction manual (SI) – safety-relevant document
Depending on the approval, the required instruction manuals are supplied with the device.

Additionally, the following parts may belong to the documentation, if applicable:

- EU-type examination certificate
- EU declaration of conformity
- Attestation of conformity
- Certificates
- Control drawings
- Functional safety manual
- Additional documents

1.2 Safety Information

Target Group, Personnel

Responsibility for planning, assembly, commissioning, operation, maintenance, and dismantling lies with the plant operator.

Only appropriately trained and qualified personnel may carry out mounting, installation, commissioning, operation, maintenance, and dismantling of the product. The personnel must have read and understood the instruction manual and the further documentation.

Prior to using the product make yourself familiar with it. Read the document carefully.

1.3 Symbols Used

This document contains symbols for the identification of warning messages and of informative messages.

Warning Messages

You will find warning messages, whenever dangers may arise from your actions. It is mandatory that you observe these warning messages for your personal safety and in order to avoid property damage.

Depending on the risk level, the warning messages are displayed in descending order as follows:



Danger!

This symbol indicates an imminent danger.

Non-observance will result in personal injury or death.



Warning!

This symbol indicates a possible fault or danger.

Non-observance may cause personal injury or serious property damage.



Caution!

This symbol indicates a possible fault.

Non-observance could interrupt the device and any connected systems and plants, or result in their complete failure.

Informative Symbols



Note

This symbol brings important information to your attention.



Action

This symbol indicates a paragraph with instructions. You are prompted to perform an action or a sequence of actions.



Reference to another section or to further documentation



Permitted

Procedures, processes or actions that are permitted.



Forbidden

Procedures, processes or actions that are forbidden.

Electrical Symbols



Ground connection

Grounded clamp, which is grounded via a grounding system.



Protective earth (PE)

Ground terminals, which must be grounded prior to establishing any other connections. The ground terminals are located on the inside and outside of the device.

Tool Symbols



Flat-blade screwdriver



Allen key



Open-ended wrench

Symbols in Graphics

1, 2, 3 ... Item numbers

A, B, C, ... Views



Explosion-hazardous area



Non-explosion-hazardous area

2 Basic Safety Instructions

2.1 Requirements for Personnel

The personnel must fulfill the following requirements to carry out the necessary tasks, e. g. commissioning and maintenance:

- Trained, qualified specialists must have a relevant qualification for the specific function and task
- Are authorized by the plant owner/operator
- Are familiar with federal/national regulations
- Must have read and understood the instructions in the manual and supplementary documentation
- Follow instructions and comply with conditions

2.2 Designated Use

- Only use the device for liquids.
- Improper use can pose hazards.
- Ensure that the device is free of defects while it is in operation.
- Use the device only for media to which the process-wetted materials have an adequate level of resistance.
- Do not exceed or drop below the limit values for the device, see manual and technical information TI01402O/98/EN.

2.2.1 Incorrect Use

The manufacturer is not liable for damage caused by improper or non-designated use.

Residual Risks

Due to heat transfer from the process, the temperature of the electronics housing and the assemblies contained therein may rise to 80 °C (176 °F) during operation.

Danger of burns from contact with surfaces!

- If necessary, ensure protection against contact to prevent burns.

2.3 Workplace Safety

For work on and with the device:

- Wear the required personal protective equipment according to federal/national regulations.

2.4 Operational Safety

Risk of injury!

- Operate the device only if it is in proper technical condition, free from errors and faults.
- The operator is responsible for ensuring failure-free operation of the device.

Modifications to the Device

Unauthorized modifications to the device are not permitted and can lead to unforeseeable dangers.

- If, despite this, modifications are required, consult with Pepperl+Fuchs.

Repair

To ensure continued operational safety and reliability:

- Only perform repair work on the device if this is expressly permitted.
- Observe federal/national regulations pertaining to the repair of an electrical device.
- Use original spare parts and accessories from Pepperl+Fuchs only.

Hazardous Area

To eliminate danger to persons or the facility when the device is used in the hazardous area (e. g. explosion protection):

- Check the nameplate to verify whether the ordered device can be used for the intended purpose in the hazardous area.
- Observe the specifications in the separate supplementary documentation that is an integral part of this manual.

2.5 Product Safety

This device is designed in accordance with good engineering practice to meet state-of-the-art safety requirements, has been tested, and left the factory in a condition in which it is safe to operate.

The device meets general safety standards and legal requirements. It also complies with the EU directives listed in the device-specific EU Declaration of Conformity. Pepperl+Fuchs confirms this by affixing the CE mark to the device.

3 Incoming Acceptance and Product Identification

3.1 Incoming Acceptance

Check the following during goods acceptance:

- Are the order codes on the delivery note and the product sticker identical?
- Are the goods undamaged?
- Do the nameplate data match the ordering information on the delivery note?
- If required (see nameplate): Are the Safety Instructions, e. g. SI, provided?



Note

If one of these conditions is not met, please contact the manufacturer's sales office.

3.2 Product Identification

The device can be identified in the following ways:

- Nameplate data
- Extended order code with breakdown of the device features on the delivery note

3.2.1 Nameplate

The information that is required by law and is relevant to the device is shown on the nameplate, e. g.:

- Manufacturer identification
- Order number, extended order code, serial number
- Technical data, degree of protection
- Firmware version, hardware version
- Approval-related information, reference to instruction manuals (SI)
- DataMatrix code (information about the device)

3.2.2 Electronic Insert



Note

Identify the electronic insert via the order code on the nameplate.

3.2.3 Manufacturer Address

Pepperl+Fuchs Group Lilienthalstraße 200, 68307 Mannheim, Germany
Internet: www.pepperl-fuchs.com

Place of manufacture: See nameplate.

3.3 Storage and Transport

3.3.1 Storage Conditions

Use original packaging.

3.3.2 Storage Temperature

-40 to +80 °C (-40 to +176 °F)

3.3.3 Device Transport



Transporting the Device

1. Transport the device to the measuring point in the original packaging.
2. Hold the device by the housing, temperature spacer, flange or extension pipe.
3. Do not bend, shorten or extend the tuning fork.

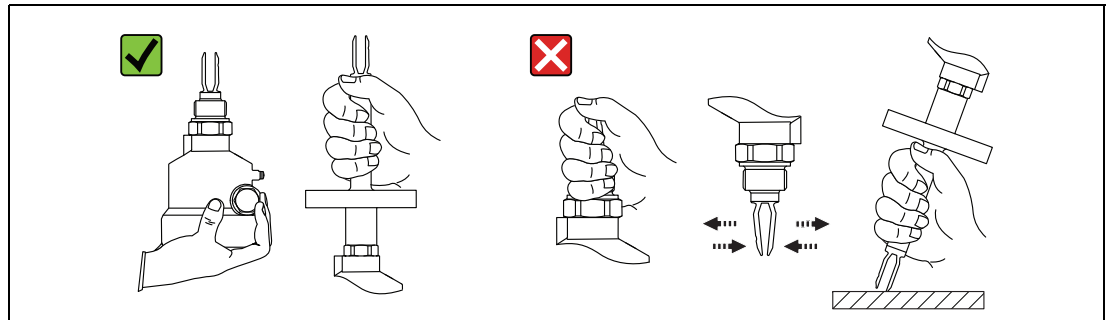

Figure 3.1 Handling the device during transportation

4 Mounting



Warning!

Loss of protection rating if the device is opened in a wet environment.

Only open the device in a dry environment!

Mounting Instructions

- Any orientation for device with short pipe up to approx. 500 mm (19.7 inch)
- Vertical orientation for device with long pipe
- Minimum distance between the fork tip and the tank wall or pipe wall: 10 mm (0.39 inch)

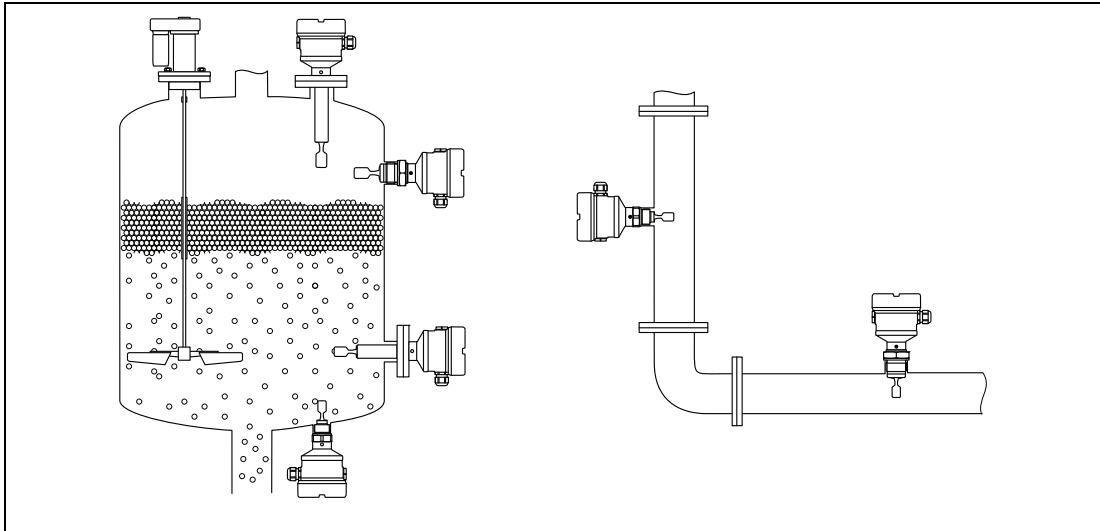

Figure 4.1 Installation examples for a vessel, tank or pipe

4.1 Mounting Requirements

4.1.1 Take Switch Point into Consideration

The following are typical switch points, depending on the orientation of the device:
 water +23 °C (+73 °F)



Note

Minimum distance between the fork tip and the tank wall or pipe wall: 10 mm (0.39 inch)

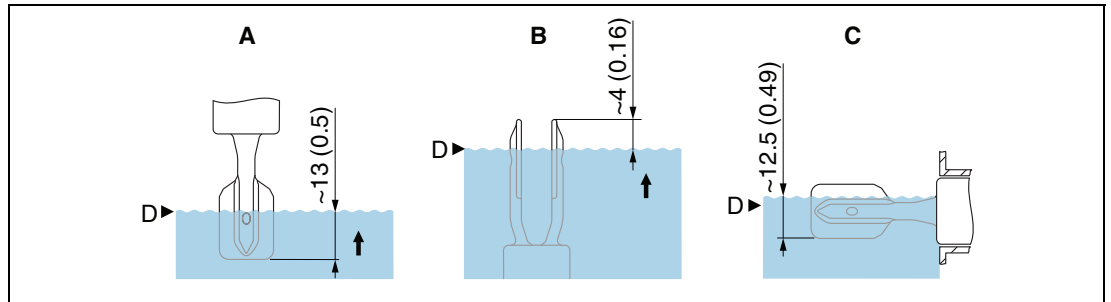

Figure 4.2 Typical switch points, unit of measurement mm (inch)

- A Installation from above
- B Installation from below
- C Installation from the side
- D Switch point

4.1.2 Take Viscosity into Consideration



Note

Viscosity values

- Low viscosity : < 2000 mPa·s
- High viscosity: > 2000 to 10000 mPa·s

Low Viscosity



Note

Low viscosity, e. g. water: < 2000 mPa·s

It is permitted to position the tuning fork within the installation socket.

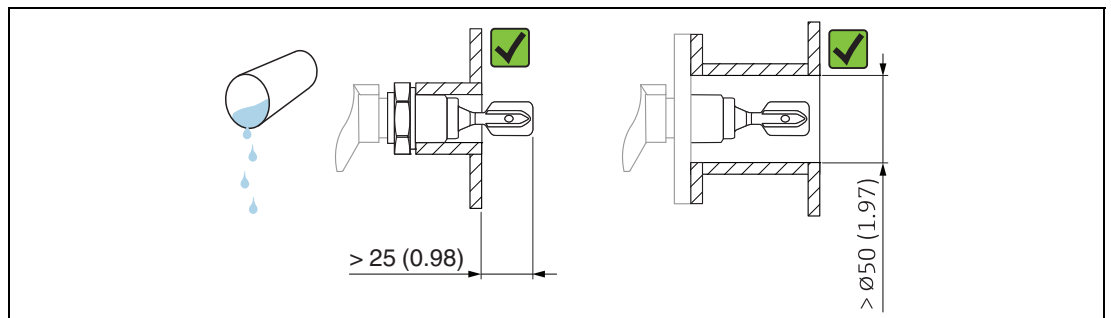

Figure 4.3 Installation example for low-viscosity liquids, unit of measurement mm (inch)

High Viscosity



Note

Highly viscous liquids may cause switching delays.

- Make sure that the liquid can run off the tuning fork easily.
- Deburr the socket surface.



Note

High viscosity, e.g. viscous oils: < 10000 mPa·s

The tuning fork must be located outside the installation socket!

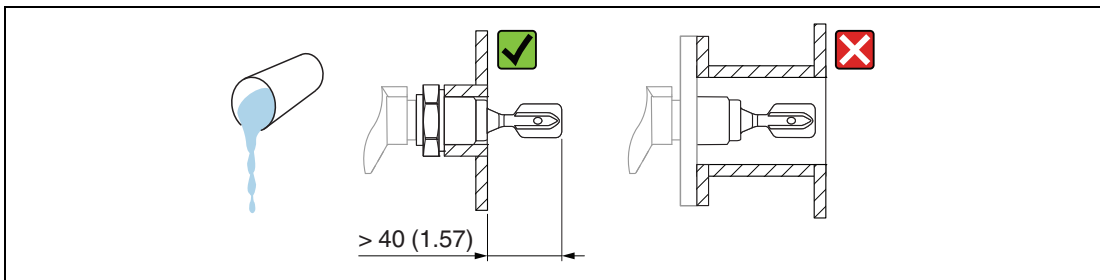

Figure 4.4 Installation example for a highly viscous liquid, unit of measurement mm (inch)

4.1.3

Avoid Buildup

- Use short installation sockets to ensure that the tuning fork can project freely into the vessel.
- Leave sufficient distance between the buildup expected on the tank wall and the tuning fork.

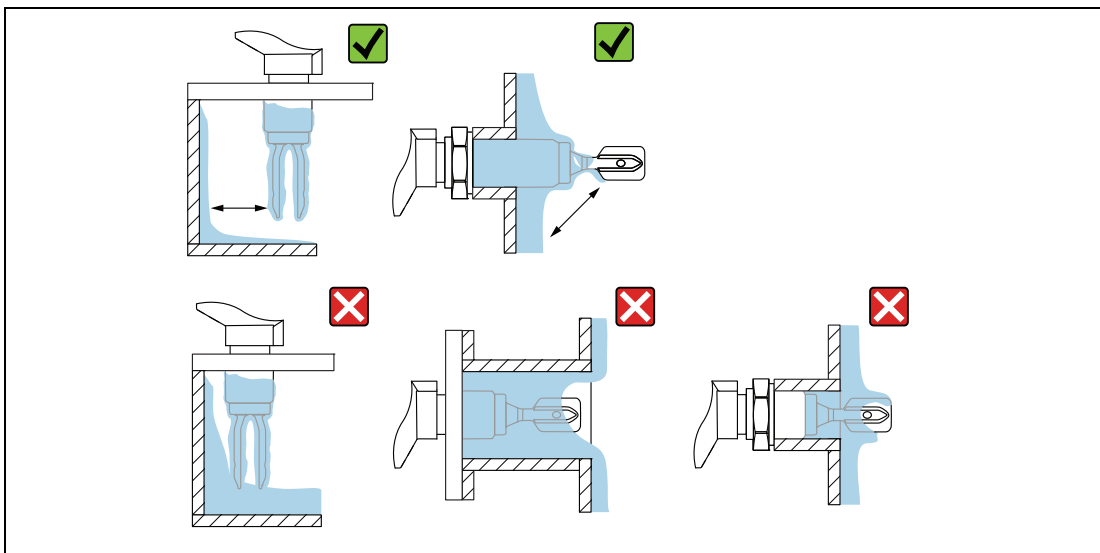

Figure 4.5 Installation examples for a highly viscous process medium

4.1.4 Take Clearance into Consideration

Allow sufficient space outside the tank for mounting, connection and settings involving the electronic insert.

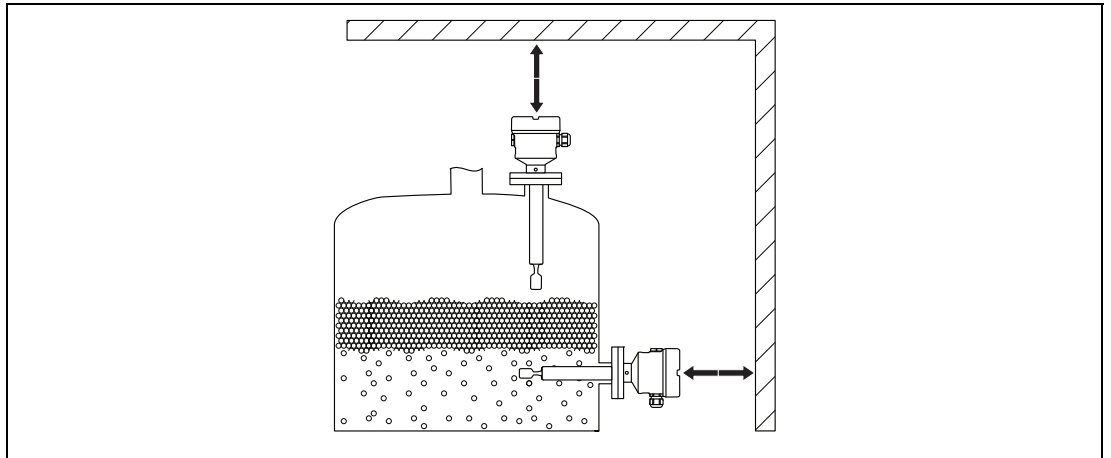

Figure 4.6 Take clearance into consideration

4.1.5 Support the Device

Support the device in the event of severe dynamic load. Maximum lateral loading capacity of the pipe extensions and sensors: 75 Nm (55 lbf foot).

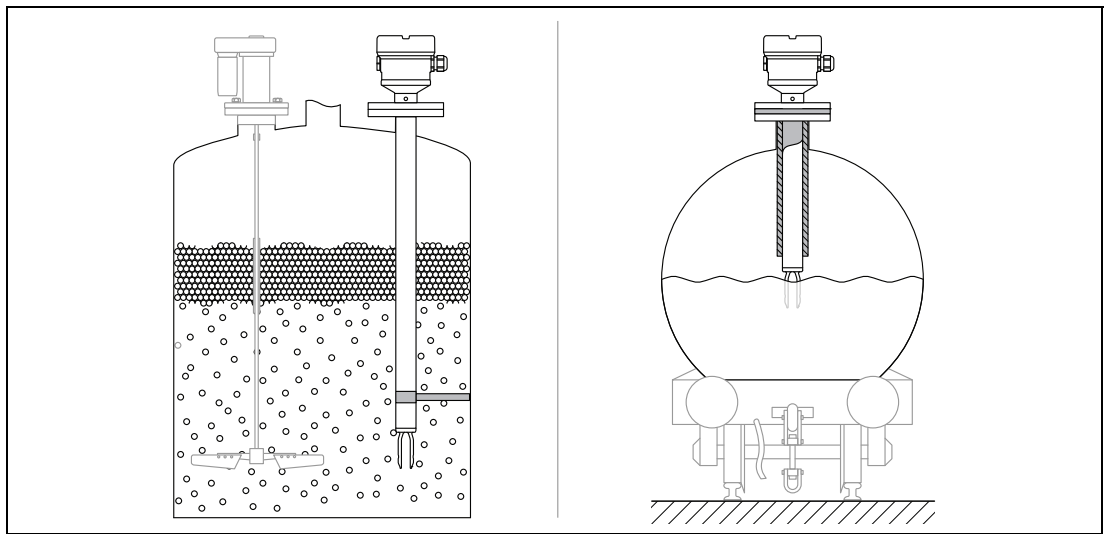

Figure 4.7 Examples of support in the event of dynamic load

4.1.6 Weld-in Adapter with Leakage Hole

Weld in the welding neck in such a way that the leakage hole is pointing downwards. This enables any leaks to be detected quickly.

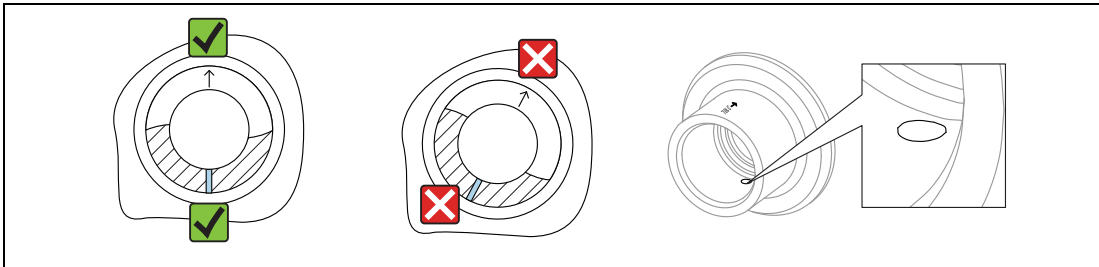

Figure 4.8 Weld-in adapter with leakage hole

4.2 Mounting the Device

Required Tools

- Open-ended wrench for sensor installation
- Allen key for housing locking screw

4.2.1 Installation

Align the Tuning Fork using the Marking

The tuning fork can be aligned using the marking. Medium can thus run off easily and buildup is avoided.

Markings may include the following:

- Material specification, thread description or circle on the hexagonal nut or on the weld-in adapter
- The II symbol on the back of the flange or Tri-Clamp

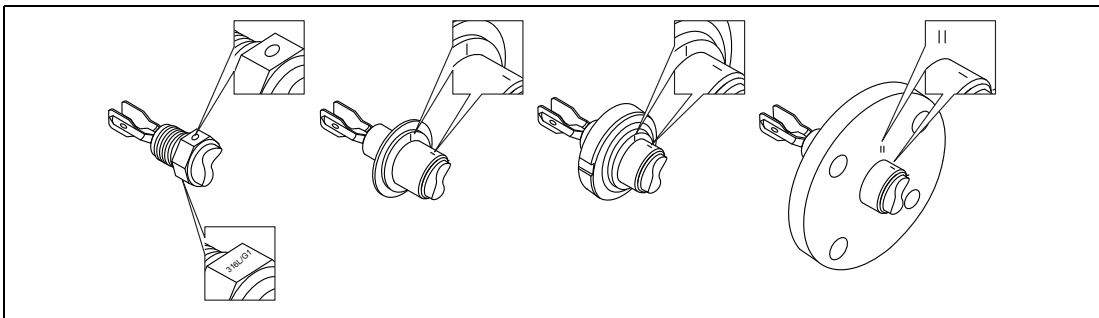

Figure 4.9 Markings to align the tuning fork

Installing in Pipes

- Flow velocities up to 5 m/s at a viscosity of 1 mPa·s and density 1 g/cm³ (SGU). Check for correct functioning in the event of other process medium conditions.
- The flow will not be significantly impeded if the tuning fork is correctly aligned and the marking is pointing in the direction of flow.
- The marking is visible when installed.

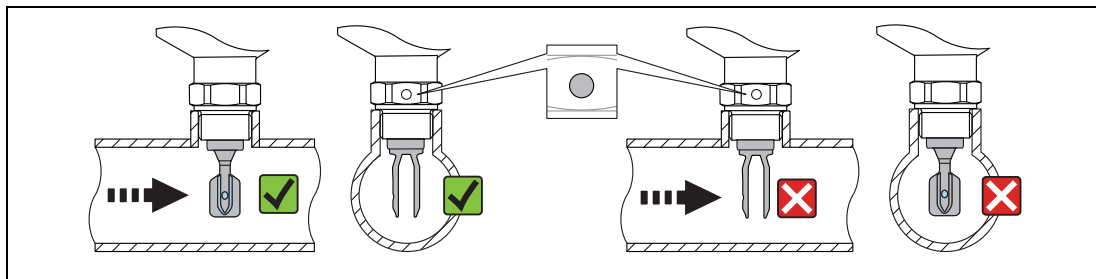

Figure 4.10 Marking and fork position

Screwing in the Device

- Turn by the hex bolt only, 15 to 30 Nm (11 to 22 lbf foot)
- Do not turn at the housing!

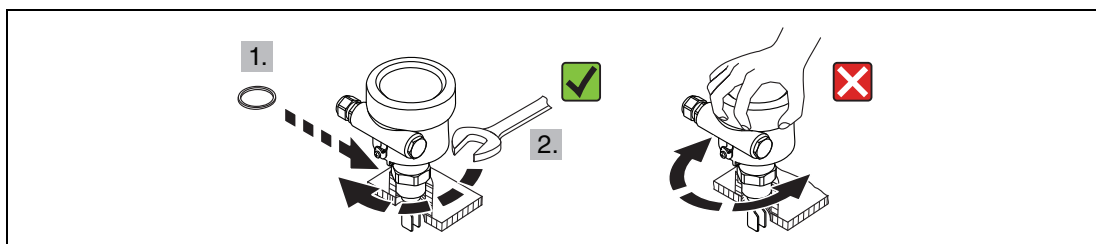

Figure 4.11 Screwing in the device

Aligning the Cable Entry



Note

The locking screw is not tightened when the device is delivered.



Aligning the Cable Entry

1. Loosen the external locking screw (maximum 1.5 turns).
2. Turn the housing, align the cable entry.
Avoid moisture in the housing, provide a loop to allow moisture to drain off.
3. Tighten the external locking screw.

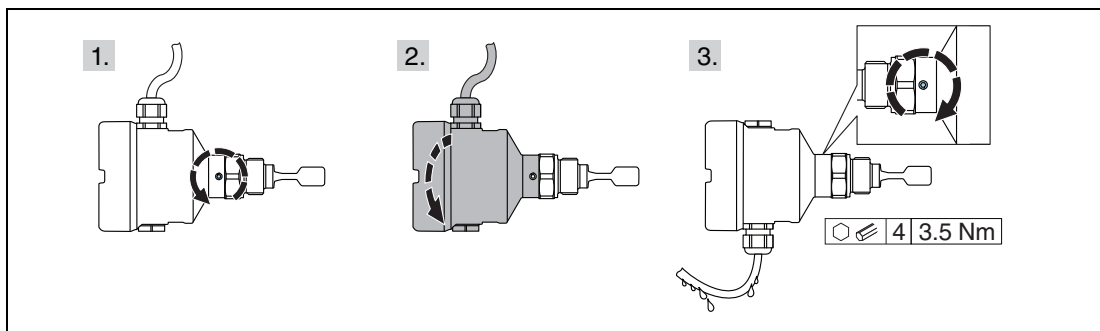

Figure 4.12 Housing with external locking screw

4.3 Sliding Sleeves

- ▶ For more information see manual.

4.4 Post-Installation Check

- Is the device undamaged (visual inspection)?
- Does the device conform to the measuring point specifications?
For example:
 - Process temperature
 - Process pressure
 - Ambient temperature
 - Measuring range
- Are the measuring point number and labeling correct (visual inspection)?
- Is the device adequately protected against precipitation and direct sunlight?
- Is the device properly secured?

5 Electrical Connection

Required Tools

- Screwdriver for electrical connection
- Allen key for screw of cover lock

5.1 Connection Requirements

5.1.1 Cover with Securing Screw

In the case of devices for use in the hazardous area with a certain type of protection, the cover is sealed by a securing screw.



Note

If the securing screw is not positioned correctly when the cover is screwed closed, the cover cannot provide secure sealing.

- Open the cover: Slacken the screw of the cover lock with a maximum of 2 turns so that the screw does not fall out. Fit the cover and check the cover seal.
- Close the cover: Screw the cover securely onto the housing, making sure that the securing screw is positioned correctly. There should not be any gap between the cover and housing.

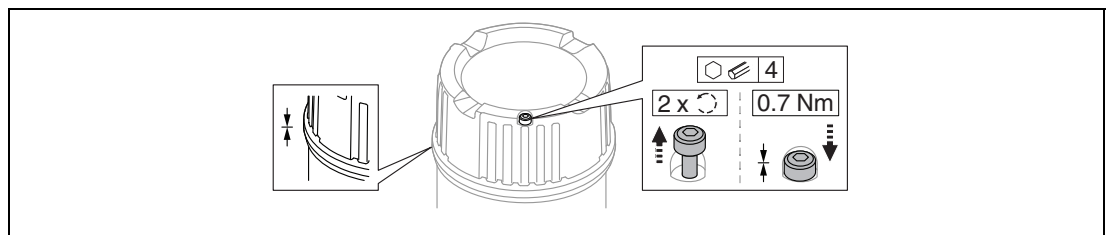

Figure 5.1 Cover with securing screw

5.1.2 Connecting Protective Earth (PE)

The protective earth conductor at the device must only be connected if the device's operating voltage is $\geq 35 \text{ V DC}$ or $\geq 16 \text{ V AC}_{\text{eff}}$.

When the device is used in hazardous areas, it must always be included in the potential equalization of the system, irrespective of the operating voltage.



Note

The plastic housing is available with or without an external protective earth connection (PE). If the operating voltage of the electronic insert is $< 35 \text{ V}$, the plastic housing has no external protective earth connection.

5.2 Connecting the Device



Caution!

Housing thread

The thread of the electronics and connection compartment is coated with lubricant varnish. Avoid additional lubrication.

5.2.1 3-Wire DC-PNP (Electronic Insert FEL42)

- 3-wire DC version
- Switches the load via the transistor (PNP) and separate connection, e. g. in conjunction with programmable logic controllers (PLC), DI modules according to EN 61131-2.

Supply Voltage



Warning!

Risk of potentially life-threatening electric shock!

Failure to use the prescribed power unit.

The electronic insert may only be powered by devices with safe galvanic isolation, as per IEC 61010-1.

$U = 10 \text{ to } 55 \text{ V DC}$



Note

Observe the following as per IEC/EN 61010-1: Provide a suitable circuit breaker for the device, and limit the current to 500 mA, e. g. by installing a 0.5 A fuse (slow-blow) in the supply circuit.

Power Consumption

$P \leq 0.5 \text{ W}$

Current Consumption

$I \leq 10 \text{ mA}$, without load

The red LED flashes in the event of an overload or short-circuit. Check for an overload or short-circuit every 5 s.

Load Current

$I \leq 350 \text{ mA}$, with overload and short-circuit protection

Residual Current

$I < 100 \text{ }\mu\text{A}$, for blocked transistor

Residual Voltage

$U < 3 \text{ V}$, for switched through transistor

Behavior of Output Signal

- OK status: switched through
- Demand mode: blocked
- Alarm: blocked

Terminals

Terminals for cable cross-section up to 2.5 mm^2 (14 AWG). Use ferrules for the wires.

Overvoltage protection

Overvoltage category II

Terminal Assignment

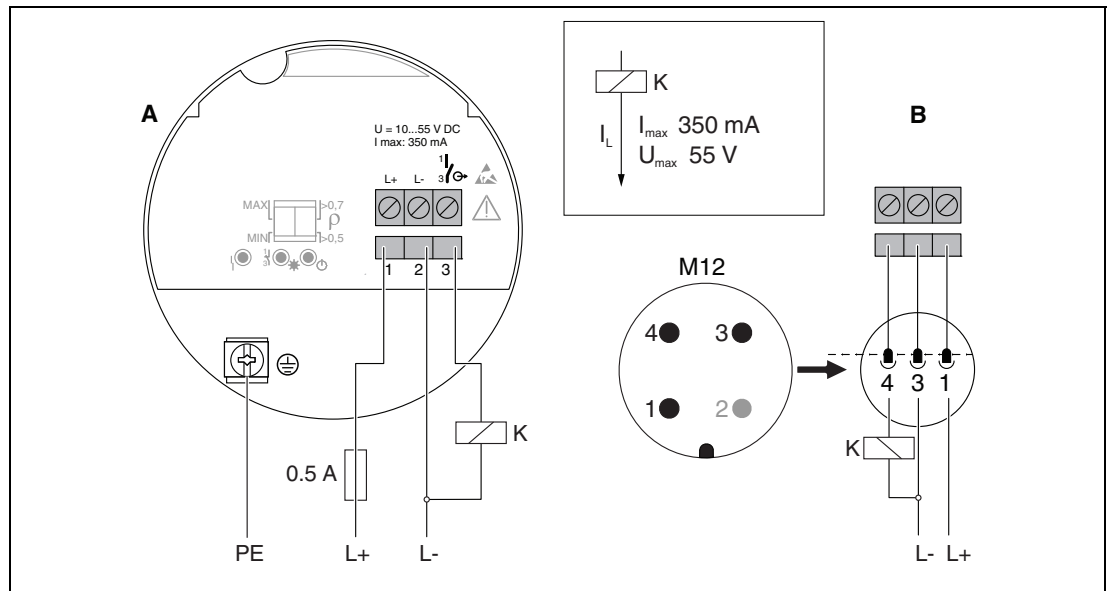

Figure 5.2 3-wire DC-PNP, electronic insert FEL42

- A Connection wiring with terminals
- B Connection wiring with M12 plug according to EN 61131-2 standard

Behavior of Switch Output and Signaling

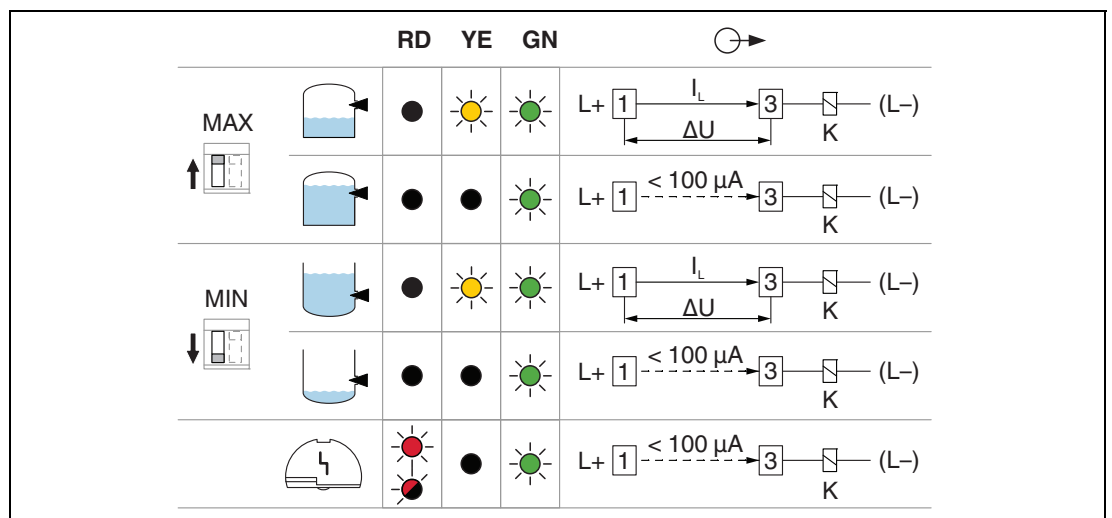

Figure 5.3 Behavior of switch output and signaling, electronic insert FEL42

- MAX** DIP switch for setting MAX safety mode
- MIN** DIP switch for setting MIN safety mode
- RD** LED red for warning or alarm
- YE** LED yellow, switch status
- GN** LED green, operational status, device on
- I_L Load current switched through

5.2.2 Universal Current Connection with Relay Output (Electronic Insert FEL44)

- Switches the loads via 2 volt-free changeover contacts
- 2 separate changeover contacts (DPDT)



Warning!

Risk of burns by hot surface

An fault at the electronic insert can cause the permitted temperature for touch-safe surfaces to be exceeded.

Do not touch the electronics in the event of a fault!

Supply Voltage

$U = 19 \text{ to } 253 \text{ V AC}, 50 \text{ Hz}/60 \text{ Hz} / 19 \text{ to } 55 \text{ V DC}$



Note

Observe the following as per IEC/EN 61010-1: Provide a suitable circuit breaker for the device, and limit the current to 500 mA, e. g. by installing a 0.5 A fuse (slow-blow) in the phase (not the neutral conductor) of the supply circuit.

Power Consumption

$S < 25 \text{ VA}, P < 1.3 \text{ W}$

Connectable Load

Loads switched via 2 volt-free changeover contacts (DPDT)

- $I_{AC} \leq 6 \text{ A}$ (Ex de 4 A), $U_{\sim} \leq 253 \text{ V AC}$; $P_{\sim} \leq 1500 \text{ VA}$, $\cos \varphi = 1$, $P_{\sim} \leq 750 \text{ VA}$, $\cos \varphi > 0.7$
- $I_{DC} \leq 6 \text{ A}$ (Ex de 4 A) to 30 V DC, $I_{DC} \leq 0.2 \text{ A}$ to 125 V

According to IEC 61010, the following applies: Total voltage from relay outputs and power supply $\leq 300 \text{ V}$.

Use electronic insert FEL42 DC PNP for small DC load currents, e. g. for connection to a PLC.

Relay contact material: silver/nickel AgNi 90/10

When connecting a device with high inductance, provide a spark suppressor to protect the relay contact. A fine-wire fuse (depending on the connected load) protects the relay contact in the event of a short-circuit.

Both relay contacts switch simultaneously.

Behavior of Output Signal

- OK status: relay energized
- Demand mode: relay de-energized
- Alarm: relay de-energized

Terminals

Terminals for cable cross-section up to 2.5 mm^2 (14 AWG). Use ferrules for the wires.

Overvoltage protection

Overvoltage category II

Terminal Assignment

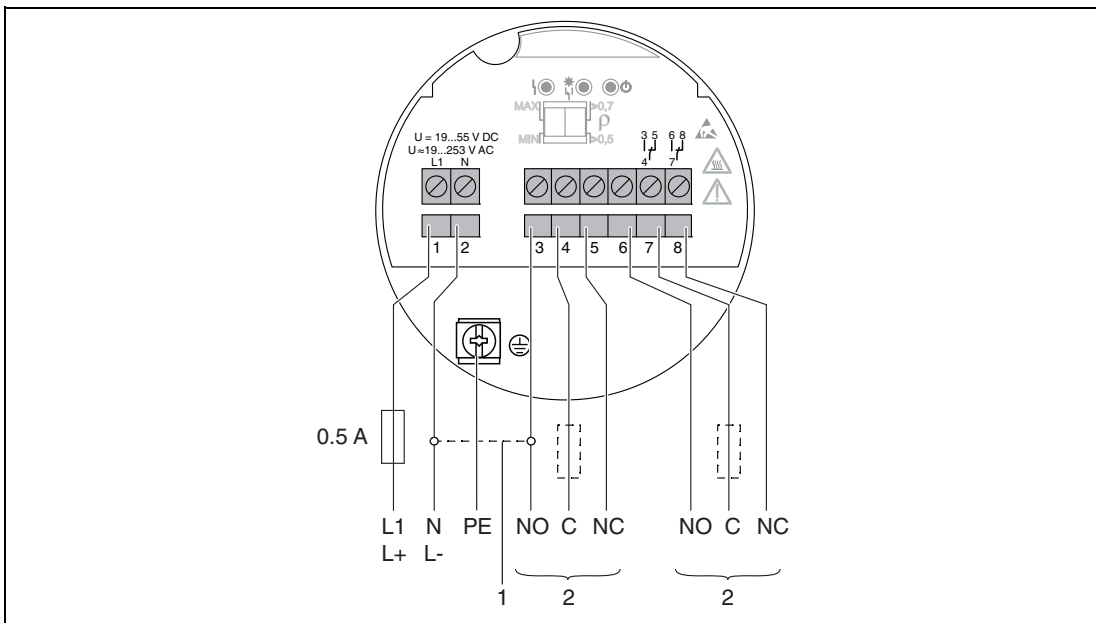

Figure 5.4 Universal current connection with relay output, electronic insert FEL44

- 1 When bridged, the relay output works with NPN logic
- 2 Connectable load

Behavior of Switch Output and Signaling

		RD	YE	GN	⊙ →
MAX ↑		●	☀	☀	3 4 5 6 7 8
		●	●	☀	3 4 5 6 7 8
MIN ↓		●	☀	☀	3 4 5 6 7 8
		●	●	☀	3 4 5 6 7 8
		●	●	☀	3 4 5 6 7 8

Figure 5.5 Behavior of switch output and signaling, electronic insert FEL44

- MAX** DIP switch for setting MAX safety mode
- MIN** DIP switch for setting MIN safety mode
- RD** LED red for alarm
- YE** LED yellow, switch status
- GN** LED green, operational status, device on

5.2.3 2-Wire NAMUR > 2.2 mA/< 1.0 mA (Electronic Insert FEL48)

- To connect to switch amplifiers according to NAMUR (IEC 60947-5-6), a permanent power supply for the electronic insert must be ensured.
- Signal transmission H-L edge 2.2 to 3.8 mA/0.4 to 1.0 mA as per IEC 60947-5-6 (NAMUR) on 2-wire cabling

Supply Voltage

U = 8.2 V DC



Note

Comply with the following according to IEC/EN61010-1: provide a suitable circuit breaker for the device.

Power Consumption

P < 50 mW

Behavior of Output Signal

- OK status: output current 2.2 to 3.8 mA
- Demand mode: output current 0.4 to 1.0 mA
- Alarm: output current 0.4 to 1.0 mA

Terminals

Terminals for cable cross-section up to 2.5 mm² (14 AWG). Use ferrules for the wires.

Overvoltage protection

Overvoltage category II

Terminal Assignment

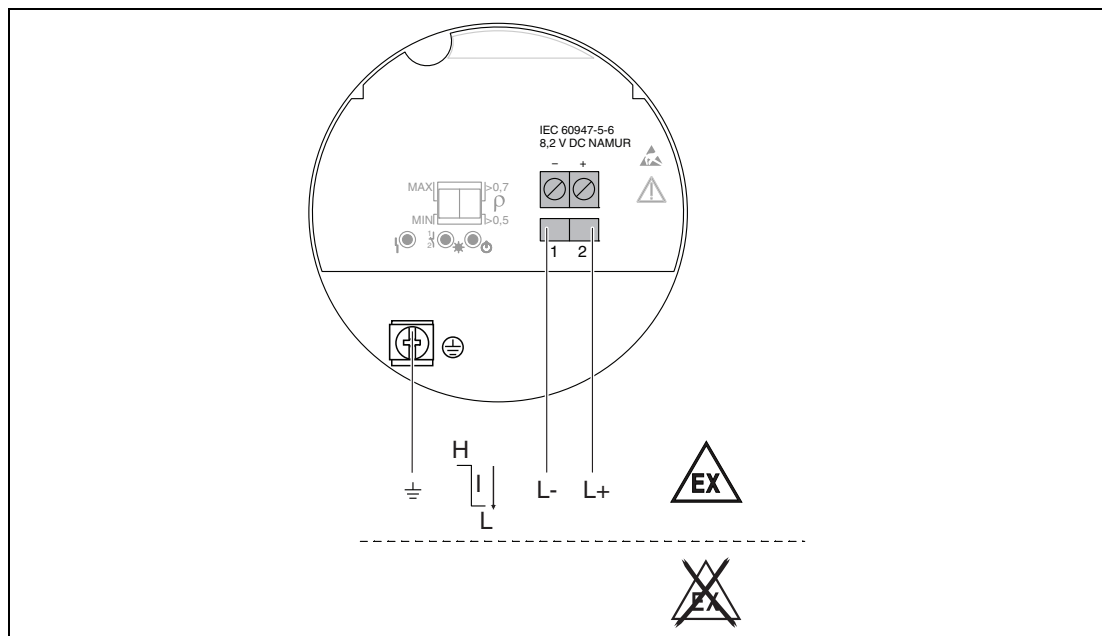

Figure 5.6 2-wire NAMUR > 2.2 mA/< 1.0 mA, electronic insert FEL48

Behavior of Switch Output and Signaling

		RD	YE	GN	⌚
MAX ↑		●	☀	☀	L+ 2 → 2.2...3.8 mA → 1 L-
		●	●	☀	L+ 2 → 0.4...1.0 mA → 1 L-
MIN ↓		●	☀	☀	L+ 2 → 2.2...3.8 mA → 1 L-
		●	●	☀	L+ 2 → 0.4...1.0 mA → 1 L-
		●	●	☀	L+ 2 → < 1.0 mA → 1 L-

Figure 5.7 Behavior of switch output and signaling, electronic insert FEL48

MAX DIP switch for setting MAX safety mode

MIN DIP switch for setting MIN safety mode

RD LED red for alarm

YE LED yellow, switch status

GN LED green, operational status, device on

5.2.4 Connecting the Cables

Required tools

- Flat-blade screwdriver (0.6 mm x 3.5 mm) for terminals
- Suitable tool with width across flats AF24/25 (8 Nm (5.9 lbf foot)) for M20 cable gland

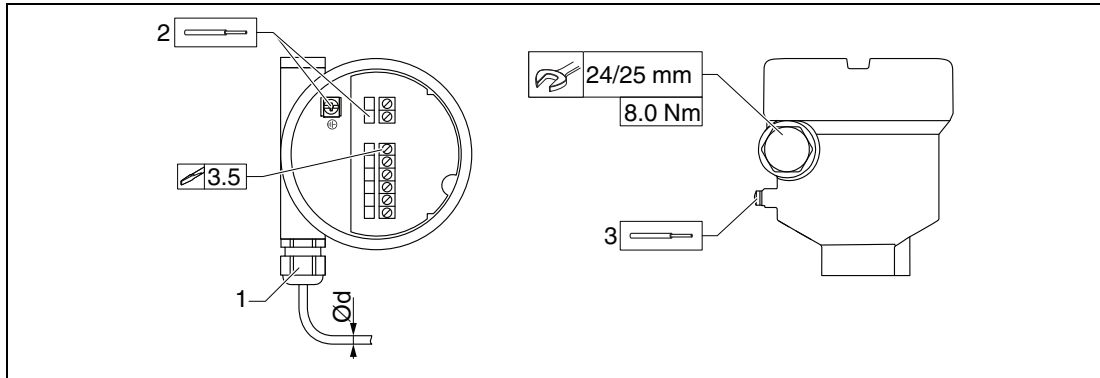

Figure 5.8 Example of coupling with cable entry, electronic insert with terminals

- 1 M20 coupling (with cable entry), example
 - 2 Conductor cross-section maximum 2.5 mm² (AWG 14), ground terminal inside the housing and terminals on the electronics
 - 3 Conductor cross-section maximum 4.0 mm² (AWG 12), ground terminal outside the housing (example of plastic housing with external protective ground connection (PE))
- Ød Nickel-plated brass 7 to 10.5 mm (0.28 to 0.41 inch)
 Ød Plastic 5 to 10 mm (0.2 to 0.38 inch)
 Ød Stainless steel 7 to 12 mm (0.28 to 0.47 inch)

Note

Pay attention to the following when using the M20 coupling

Following cable entry:

- Counter-tighten the coupling.
- Tighten the union nut of the coupling with a torque of 8 Nm (5.9 lbf foot).
- Screw the enclosed coupling into the housing with a torque of 3.75 Nm (2.76 lbf foot).

5.3 Post-Connection Check

- Is the device or cable undamaged (visual inspection)?
- Do the cables used comply with the requirements?
- Do the mounted cables have adequate strain relief?
- Are the cable glands mounted and firmly tightened?
- Does the supply voltage match the information on the nameplate?
- No reverse polarity, is terminal assignment correct?
- If supply voltage is present, is the green LED lit?
- Are all the housing covers installed and tightened?
- Optional: Is the cover tightened with securing screw?

6 Operation Options

6.1 Overview of Operation Options

6.1.1 Operating Concept

Operation with DIP switches on the electronic insert

6.1.2 Elements on the Electronic Insert

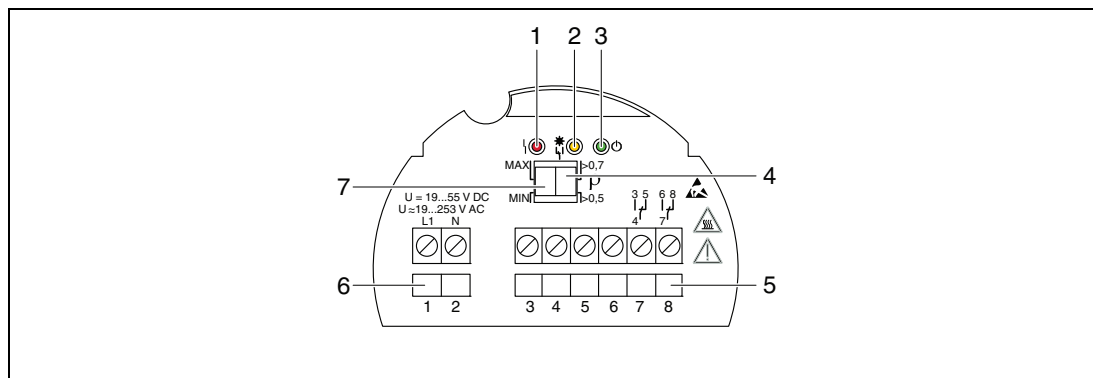

Figure 6.1 Example of electronic insert FEL44

- 1 LED red, for warning or alarm
- 2 LED yellow, switch status
- 3 LED green, operational status (LED green lights up = device on)
- 4 DIP switch to set the density to 0.7 or 0.5
- 5 Relay contact terminals
- 6 Power supply terminals
- 7 DIP switch for setting MAX/MIN safety

7 Commissioning

7.1 Function Check

Before commissioning the measuring point, check whether the post-installation and post-connection checks have been performed:

- ▶ Post-installation check see chapter 4.4
- ▶ Post-connection check see chapter 5.3

7.2 Switching on the Device

During the power-up time, the device output is in the safety-oriented state, or in the alarm state if available.

The output will be in the correct state max. 3 seconds after powering up the device.

7.3 Further Information



Note

Further information is available on the product detail page of the devices on the Internet at www.pepperl-fuchs.com.

Enter the order designation in the search field → Select the appropriate product → Open the product detail page → Open the **Documents** tab.

Your automation, our passion.

Explosion Protection

- Intrinsic Safety Barriers
- Signal Conditioners
- FieldConnex® Fieldbus
- Remote I/O Systems
- Electrical Ex Equipment
- Purge and Pressurization
- Industrial HMI
- Mobile Computing and Communications
- HART Interface Solutions
- Surge Protection
- Wireless Solutions
- Level Measurement

Industrial Sensors

- Proximity Sensors
- Photoelectric Sensors
- Industrial Vision
- Ultrasonic Sensors
- Rotary Encoders
- Positioning Systems
- Inclination and Acceleration Sensors
- Fieldbus Modules
- AS-Interface
- Identification Systems
- Displays and Signal Processing
- Connectivity

Pepperl+Fuchs Quality
Download our latest policy here:

www.pepperl-fuchs.com/quality

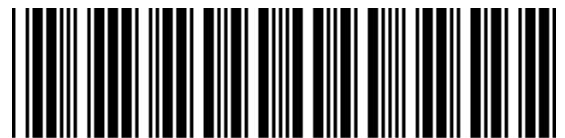

71556574