

Functional Safety

**Vibration Limit Switch
LVL-M4 with Electronic
Insert FEL62**

Manual

SIL

IEC 61508/61511



SIL2
SIL3



With regard to the supply of products, the current issue of the following document is applicable:
The General Terms of Delivery for Products and Services of the Electrical Industry, published by the Central Association of the Electrical Industry (Zentralverband Elektrotechnik und Elektroindustrie (ZVEI) e.V.) in its most recent version as well as the supplementary clause: "Expanded reservation of proprietorship"

Worldwide

Pepperl+Fuchs Group
Lilienthalstr. 200
68307 Mannheim
Germany
Phone: +49 621 776 - 0
E-mail: info@de.pepperl-fuchs.com

North American Headquarters

Pepperl+Fuchs Inc.
1600 Enterprise Parkway
Twinsburg, Ohio 44087
USA
Phone: +1 330 425-3555
E-mail: sales@us.pepperl-fuchs.com

Asia Headquarters

Pepperl+Fuchs Pte. Ltd.
P+F Building
18 Ayer Rajah Crescent
Singapore 139942
Phone: +65 6779-9091
E-mail: sales@sg.pepperl-fuchs.com
<https://www.pepperl-fuchs.com>

1	Introduction	5
1.1	Content of this Document	5
1.2	Safety Information	6
1.3	Symbols Used	6
2	Supplementary Documentation	8
2.1	Further Applicable Documents	8
2.2	Technical Information (TI)	8
2.3	Manual (BA)	8
2.4	Brief Instructions (KA)	8
2.5	Instruction Manual (SI)	8
3	Requirements and Assumptions	9
3.1	Permitted Device Types	9
3.2	Identification Marking	10
3.3	Safety Function	10
3.4	Basic Conditions for Use in Safety-Related Applications	10
3.5	Useful Lifetime of Electric Components	13
4	Characteristic Safety Values	14
4.1	Device with Electronic Insert FEL62	14
5	Commissioning	15
5.1	Requirements for Personnel	15
5.2	Installation	15
5.3	Commissioning	15
5.4	Operation	15
5.5	Parameter Configuration for Safety-Related Applications	15
6	Operation	17
6.1	Device Behavior During Power-Up	17
6.2	Device Behavior in Safety Function Demand Mode	17
6.3	Device Behavior in the Event of an Alarm	17

7	Proof Test	18
7.1	Basic Test Sequence	19
7.2	Test Sequence A, MIN Detection	20
7.3	Test Sequence A, MAX Detection.....	21
7.4	Test Sequence B, Simulation with Test Button or Test Magnet on the Device	22
7.5	Verification Criterion	23
8	Repair and Fault Handling	24
8.1	Maintenance	24
8.2	Repair	24
8.3	Modification	24
8.4	Decommissioning	25
8.5	Disposal	25
9	Appendix	26
9.1	Structure of the Measuring System.....	26

1 Introduction

1.1 Content of this Document

This document contains information for usage of the device in functional safety-related applications. You need this information to use your product throughout the applicable stages of the product life cycle. These can include the following:

- Product identification
- Delivery, transport, and storage
- Mounting and installation
- Commissioning and operation
- Maintenance and repair
- Troubleshooting
- Dismounting
- Disposal



Note

This document does not substitute the instruction manual.



Note

For full information on the product, refer to the instruction manual and further documentation on the Internet at www.pepperl-fuchs.com.



Note

For specific device information such as the year of construction, scan the QR code on the device. As an alternative, enter the serial number in the serial number search at www.pepperl-fuchs.com.

The documentation consists of the following parts:

- Present document
- Instruction manual
- Manual
- Datasheet

Additionally, the following parts may belong to the documentation, if applicable:

- EU-type examination certificate
- EU declaration of conformity
- Attestation of conformity
- Certificates
- Control drawings
- FMEDA report
- Assessment report
- Additional documents

For more information about Pepperl+Fuchs products with functional safety, see www.pepperl-fuchs.com/sil.

1.2 Safety Information

Target Group, Personnel

Responsibility for planning, assembly, commissioning, operation, maintenance, and dismantling lies with the plant operator.

Only appropriately trained and qualified personnel may carry out mounting, installation, commissioning, operation, maintenance, and dismantling of the product. The personnel must have read and understood the instruction manual and the further documentation.

Intended Use

The device is only approved for appropriate and intended use. Ignoring these instructions will void any warranty and absolve the manufacturer from any liability.

The device is developed, manufactured and tested according to the relevant safety standards.

Use the device only

- for the application described
- with specified environmental conditions
- with devices that are suitable for this safety application

Improper Use

Protection of the personnel and the plant is not ensured if the device is not used according to its intended use.

1.3 Symbols Used

This document contains symbols for the identification of warning messages and of informative messages.

Warning Messages

You will find warning messages, whenever dangers may arise from your actions. It is mandatory that you observe these warning messages for your personal safety and in order to avoid property damage.

Depending on the risk level, the warning messages are displayed in descending order as follows:



Danger!

This symbol indicates an imminent danger.

Non-observance will result in personal injury or death.



Warning!

This symbol indicates a possible fault or danger.

Non-observance may cause personal injury or serious property damage.



Caution!

This symbol indicates a possible fault.

Non-observance could interrupt the device and any connected systems and plants, or result in their complete failure.

Informative Symbols



Note

This symbol brings important information to your attention.



Action

This symbol indicates a paragraph with instructions. You are prompted to perform an action or a sequence of actions.



Reference to another section or to further documentation



Permitted

Procedures, processes or actions that are permitted.



Forbidden

Procedures, processes or actions that are forbidden.

Symbols in Graphics

1, 2, 3 ... Item numbers

A, B, C, ... Views



Explosion-hazardous area



Non-explosion-hazardous area

2 Supplementary Documentation



Note

For further information is available on the product detail page of the devices on the Internet at www.pepperl-fuchs.com.

Enter the order designation in the search field → Select the appropriate product → Open the product detail page → Open the **Documents** tab.

2.1 Further Applicable Documents

- TI01403O
- BA01894O
- KA01429O

2.2 Technical Information (TI)

Planning aid

The document contains all the technical data on the device and provides an overview of the accessories and other products that can be ordered for the device.

2.3 Manual (BA)

Your reference guide

This document contains all the information that is required in various phases of the life cycle of the device: from product identification, incoming acceptance and storage, to mounting, connection, operation and commissioning through to troubleshooting, maintenance and disposal.

2.4 Brief Instructions (KA)

Guide that takes you quickly to the 1st measured value

This document contains all the essential information from incoming acceptance to initial commissioning.

2.5 Instruction Manual (SI)

Depending on the approval, the following instruction manuals (SI) are supplied with the device. These documents are an integral part of the manual.



Note

The nameplate indicates the instruction manual (SI) that are relevant to the device.

3 Requirements and Assumptions

3.1 Permitted Device Types

The details pertaining to functional safety in this manual relate to the device options listed below and are valid as of the specified firmware and hardware versions.

Unless otherwise specified, all subsequent versions can also be used for safety functions.

A modification process according to IEC 61508 is applied for device changes.

Valid device versions for safety-related use

L	V	L	-	M	4	-	(1)	(2)	(3)	(4)	-	(5)	(6)	(7)	(8)	(9)	(10)	-	(11)	(12)	.	L
---	---	---	---	---	---	---	-----	-----	-----	-----	---	-----	-----	-----	-----	-----	------	---	------	------	---	---

Basic specifications

LVL-M4	Device
LVL-M4	Vibration limit switch for liquids
(1)	Type of probe
X	all options
(2)	Process connection, sealing surface
X	all options
(3)	Process connection
XXX	all options
(4)	Sensor length, material
X	all options
(5)	Housing, material
X	all options
(6)	Electrical connection
X	all options
(7)	Application, temperature
X	all options
(8)	Surface refinement
X	all options
(9)	Electrical output
E	FEL62, 3-wire PNP, 10 V DC to 55 V DC with test button
(10)	Display, operation
X	all options
(11)	Approval
XX	all options

2022-07

Additional Options

(12)	Additional approval
SL	SIL Functional Safety

3.2 Identification Marking

SIL-certified devices are marked with the SIL logo on the nameplate.

3.3 Safety Function

The device's safety functions are:

- Maximum level monitoring (overflow prevention, MAX detection)
- Minimum level monitoring (dry running protection, MIN detection)

3.4 Basic Conditions for Use in Safety-Related Applications

The measuring system must be used correctly for the specific application, taking into account the medium properties and ambient conditions. Carefully follow instructions pertaining to critical process situations and installation conditions from the instruction manuals.

The application-specific limits must be observed. The specifications in the instruction manuals and the technical information must not be exceeded.

3.4.1 Density of the Medium

Operation is only permitted with liquids:

- Depending on the configured density setting, the density of the liquid must be as follows:
 - if the switch position is > 0.7 the density must be over 0.7 g/cm³ (common water- and oil-based liquids).
 - if the switch position is > 0.5 the density must be over 0.5 g/cm³ (e. g., liquefied gas, isopentane, petroleum ether).
- The gas phase above the liquid may not exceed a maximum permitted density value. The maximum possible gas density depends on the temperature and the device.

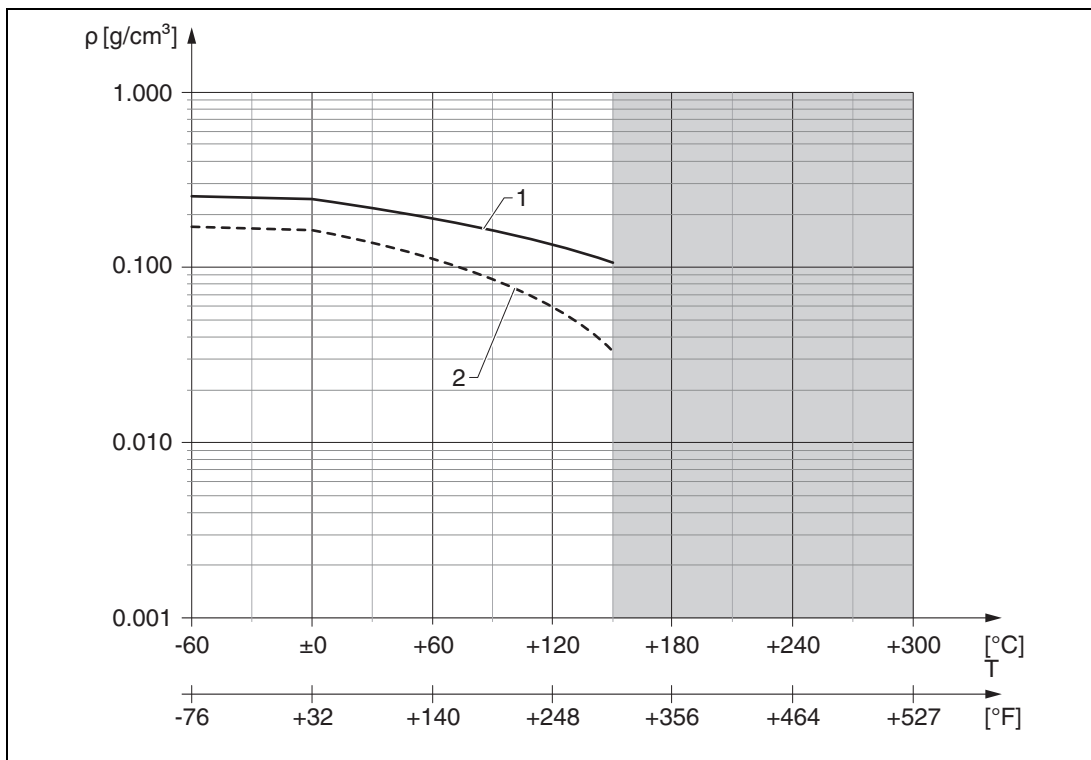

Figure 3.1 Density of gas phase above the medium

- 1 Switch position for density 0.7 g/cm³
- 2 Switch position for density 0.5 g/cm³



Warning!

Danger of explosion due to excessive gas density!

Free status is not detected and **Covered** is always signaled.

The gas density may not be exceeded.



Note

- There is no minimum density for the gas phase.
- Operation in a vacuum is permitted.
- There is no maximum density for the liquid.
- For more information on the levels of diagnostic coverage, refer to IEC 61508-2:2010 Appendix A.2, Comment 2 and Table A.1.

3.4.2 Buildup (only for MIN Detection)

The device may only be used in media that do not tend to cause buildup. Buildup is considered to be any deposits with a thickness of over 0.5 mm (0.02 inch). Buildup can have the effect that the demand mode of the safety function is not detected and the device will not switch as intended.



Note

Buildup from 0.5 mm (0.02 inch) is detected with low diagnostic coverage.

3.4.3 Solid Particles - Heterogeneous Mixtures (only for MIN Detection)

The medium may not contain solid particles with a diameter greater than 5 mm (0.2 inch). Solid particles lodged between the tines of the tuning fork can have the effect that the demand mode of the safety function is not detected and the device will not switch as intended.



Note

Lodged solid particles are detected with low diagnostic coverage.

3.4.4 Wall Distance

The distance between the tuning fork of the device and the wall of the vessel containing medium (e. g. tank, pipe) must be at least 10 mm (0.39 inch).

3.4.5 Corrosion

The device may only be used in media to which the wetted parts used are resistant. Corrosion can have the effect that the demand mode of the safety function is not detected and the device will not switch as intended.



Note

Corrosion is detected with low diagnostic coverage.

When using coated sensors, make sure the sensor is not damaged during installation and operation.

3.4.6 Abrasion

It is not permitted to use the device with abrasive media. The removal of material from the sensor as a result of abrasion can result in sensor failure.



Note

Abrasion is detected with low diagnostic coverage.

3.4.7 Flow Velocity

In the case of flowing media, the flow velocity in the area around the tuning fork may not exceed 5 m/s. Higher flow velocities can have the effect that the demand mode is not detected and the sensor signals that it is free (uncovered).

3.4.8 External Vibration

In systems exposed to strong external vibrations, e. g., in the 400 to 1200 Hz range (acceleration spectral density $> 1 \text{ (m/s}^2\text{)}^2\text{/Hz}$) or ultrasound with cavitation, the safety function must be verified by simulating a demand mode prior to operation. Accidental switchings may sporadically occur if a strong frequency from an external source is superimposed on the frequency of the tuning fork.

3.4.9 EMC Compatibility

The device is certified in accordance with IEC 61326-3-1 and is thus suitable for general industrial, safety-related applications. If the specified electromagnetic ambient conditions are exceeded, the switch status might not be reliably detected. An unshielded cable can be used between the devices in these environmental conditions. Electromagnetic interference immunity can be further improved by using shielded cables.

3.4.10 Mounting the Device with a Sliding Sleeve

Particular care is required when mounting the device with a pipe extension in conjunction with a sliding sleeve. The operator must implement appropriate measures to ensure that the switch point is not tampered with or that any tampering is reliably detected.

3.4.11 COM Interface

When used as a safety function, only one of the additional modules mentioned below may be connected, as an option, to the COM interface.

- Bluetooth: *Bluetooth*[®] module VU121
- Optical display: LED module VU120

Both modules may be used for informational purposes only but not as part of the safety function. They do not have a modifying effect on the safety function.

A proof test must be performed after the LED module is installed.

3.5 Useful Lifetime of Electric Components

The established failure rates of electrical components apply within the useful lifetime as per IEC 61508-2:2010 section 7.4.9.5 note 3.

According to DIN EN 61508-2:2011 section 7.4.9.5 (national footnote N3) appropriate measures taken by the operator can extend the useful lifetime.

4 Characteristic Safety Values

4.1 Device with Electronic Insert FEL62

Parameters		Characteristic values	
Assessment type and documentation		Full assessment	
Device type		B	
Mode of operation		Low demand mode oder high demand mode ¹	
Safety function		Overfill prevention, MAX detection or dry running protection, MIN detection	
Valid hardware version		01.00.ww (ww: any double number)	
Valid software version		01.01.zz (zz: any double number)	
HFT		0, SIL2 capable ≥ 1, SIL3 capable	
SIL		2 – single channel use (HFT = 0) 3 – multi channel use (HFT ≥ 1)	
Safety function		MIN	MAX
$\lambda_{su}^{2,3}$		129 FIT	145 FIT
$\lambda_{sd}^{2,3}$		5 FIT	41 FIT
$\lambda_{dd}^{2,3}$		140 FIT	106 FIT
$\lambda_{du}^{2,3}$		31 FIT	19 FIT
$\lambda_{total}^{2,3}$		305 FIT	307 FIT
SFF		90 %	95 %
PTC ⁴	Test sequence A	94 %	95 %
	Test sequence B	15 %	29 %
PFH ³		3.06×10^{-8} 1/h	1.52×10^{-8} 1/h
PFD _{avg} for T ₁ = 1 year ³ (1-channel architecture)		1.34×10^{-4}	6.67×10^{-5}
Diagnostic test interval ⁵		≤ 60 s, except RAM check ≤ 10 min	
Reaction time ⁶		≤ 3 s	

Table 4.1

¹ Observe limitation by diagnostic test interval

² FIT = Failure In Time, number of failures per 10⁹ h

³ Valid for average ambient temperature up to +40 °C (+104 °F)

For continuous operation at ambient temperature close to +60 °C (+140 °F), a factor of 1.5 should be applied

⁴ PTC = Proof Test Coverage

⁵ All diagnostic functions are performed at least once within the diagnostic test interval

⁶ Maximum time between fault detection and fault reaction

5 Commissioning

5.1 Requirements for Personnel

The personnel for installation, commissioning, diagnostics and maintenance must fulfill the following requirements:

- Trained, qualified specialists must have a relevant qualification for this specific function and task.
- Personnel must be authorized by the plant owner/operator.
- Be familiar with federal/national regulations.
- Before starting work: personnel must read and understand the instructions in the manual and supplementary documentation as well as the certificates (depending on the application).
- Personnel must follow instructions and comply with general policies.

The operating personnel must fulfill the following requirements:

- Personnel are instructed and authorized according to the requirements of the task by the facility's owner-operator.
- Personnel follow the instructions in this manual.

5.2 Installation

The mounting and wiring of the device and the permitted orientations are described in the manual pertaining to the device.

5.3 Commissioning

The device is commissioned using the Commissioning Wizard. The commissioning procedure is described in the manual pertaining to the device.

Prior to operating the device in a safety instrumented system, verification must be performed by carrying out a test sequence as described in section 7.

5.4 Operation

The operation of the device is described in the manual pertaining to the device.

5.5 Parameter Configuration for Safety-Related Applications

The device settings may not be changed if SIL operation is in progress.



Warning!

The safety function can be impaired.

After commissioning the measuring system, changes to the settings can impact the safety function.

After changing the settings, perform a proof test to ensure that the safety function is working correctly.

5.5.1 MIN/MAX Detection Mode

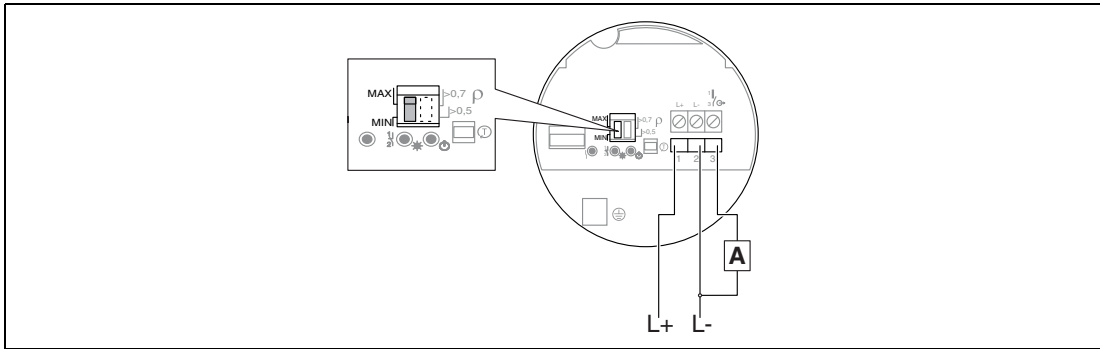

Figure 5.1 Selection of MIN/MAX detection mode

A Additional safety equipment

5.5.2 Density Mode

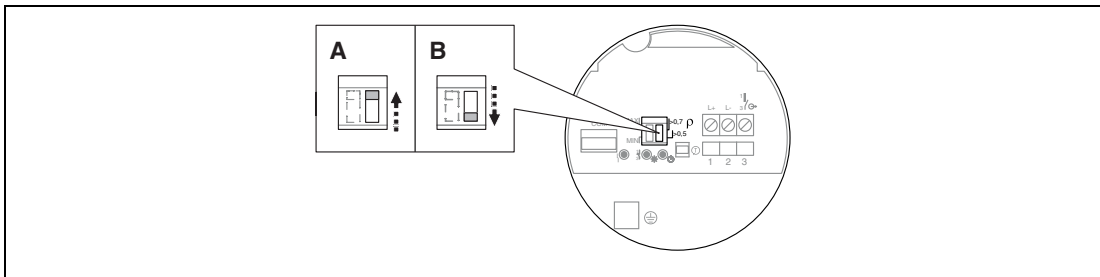

Figure 5.2 Selection of density mode

- A** Default setting (density $>0.7 \text{ g/cm}^3$), always use this setting where possible.
- B** Special setting (density $>0.5 \text{ g/cm}^3$), extremely light liquids (e. g., liquefied natural gas, isopentane, petroleum ether)

6 Operation



Danger!

Danger to life from missing safety function

If the safety loop is put out of service, the safety function is no longer guaranteed.

- Do not deactivate the device.
 - Do not bypass the safety function.
 - Do not repair, modify, or manipulate the device.
-

6.1 Device Behavior During Power-Up

The behavior of the device when switched on is described in the relevant manual.

6.2 Device Behavior in Safety Function Demand Mode

The safety-related output signal consists of a switching transistor (PNP).

- When the status is OK, the switching transistor is switched (ON).
- In demand mode, or if a fault is detected in the device, the switching transistor is locked (OFF, residual current < 100 μ A).

6.3 Device Behavior in the Event of an Alarm

The behavior of the device in the event of an alarm is described in the relevant manual.

7 Proof Test



Warning!

The safety function can be impaired.

The functional integrity of the device in the SIL mode must be verified during commissioning, when changes are made to safety-related parameters, as well as at appropriate time intervals. The operator must determine the time intervals.



Warning!

The safety function is not guaranteed during a proof test.

Suitable measures must be taken to guarantee process safety during the test.

Proof testing of the device can be performed as follows:

- Test sequence A: Approach the level, or remove and immerse in a medium of similar density and viscosity
 - Test sequence A, MIN detection
 - Test sequence A, MAX detection
 - Test sequence B: simulation using test button on the device
-



Note

Note the following for the test sequences:

- A demand mode or a fault takes absolute precedence over the proof test and in the measuring system safety path. For this reason, the demand mode must first be ended or the fault rectified before the proof test can commence.
 - The proof test can and may only be performed if the device status is OK.
 - The status of the individual output signal is indicated by a measuring device or a downstream component of the safety path (e. g., PLC, actuator).
 - The individual proof test coverages (PTC) that can be used for calculation are specified in the Declaration of Conformity.
 - To monitor the safety-related output signal, it is sufficient to evaluate the response of downstream components of the safety function. If the different states are correctly identified there, the test steps are passed.
-

7.1 Basic Test Sequence

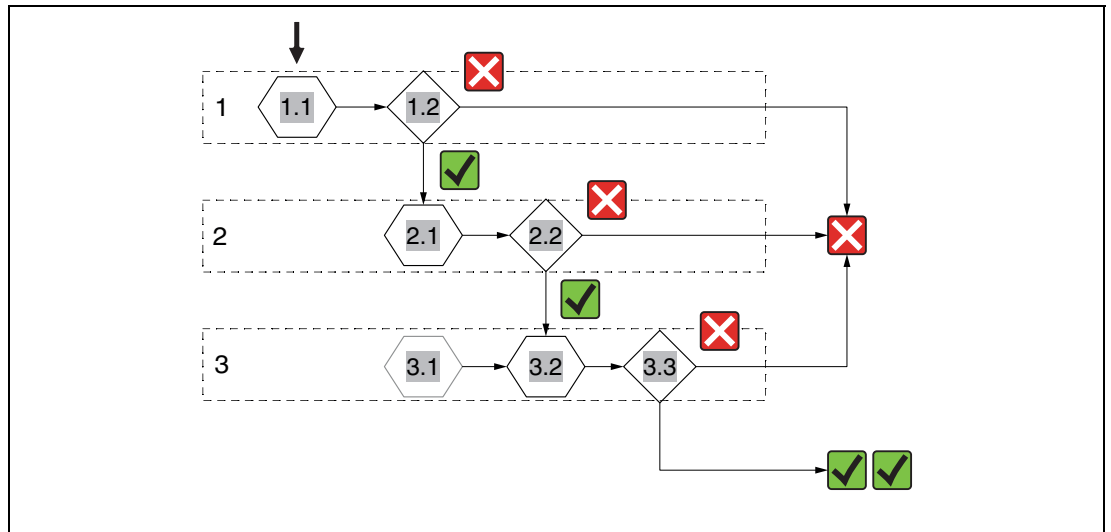

Figure 7.1 Basic test sequence

- 1.1 Status OK
- 1.2 Output signal for status OK?
- 2.1 Establish demand mode
- 2.2 Output signal for demand mode?
- 3.1 Re-install the sensor that was removed (optional)
- 3.2 Establish status OK
- 3.3 Output signal for status OK?



Note

The output signal can be evaluated based on the response of the following components of the safety function.

7.2 Test Sequence A, MIN Detection

- Approach the level or
- Remove and immerse in a medium of similar density and viscosity



Proof Test Procedure, Step 1

1. Raise the level or immerse the tuning fork of the sensor that has been removed into the medium until the tuning fork is fully covered.
 - ↳ If it is not possible to do this with the original medium, a medium of a similar density and viscosity must be used.
2. Check continuity between terminal 1 and 3.
 - ↳ The switching transistor must be switched through.



Note

If the switching transistor is locked, there is a fault in the safety path. The proof test has not been passed and must be aborted



Proof Test Procedure, Step 2

1. Lower the level or take the tuning fork of the sensor that has been removed out of the medium until the tuning fork is completely free.
 - ↳ Wait for the switching delay to elapse (1 s, unless ordered otherwise).
2. Check continuity between terminal 1 and 3.
 - ↳ The switching transistor must be locked.



Note

If the switching transistor is switched through, there is a fault in the safety path. The proof test has not been passed and must be aborted



Proof Test Procedure, Step 3

1. Re-install the sensor that was removed (optional).
 - ↳ Wait for power-up (10 s).
2. Restore the status OK by fully covering the tuning fork.
 - ↳ Wait for the switching delay to elapse (1 s, unless ordered otherwise).
3. Check continuity between terminal 1 and 3.
 - ↳ The switching transistor must be switched through.



Note

If the switching transistor is locked, there is a fault in the safety path. The proof test has not been passed and must be aborted

7.3 Test Sequence A, MAX Detection

- Approach the level or
- Remove and immerse in a medium of similar density and viscosity



Proof Test Procedure, Step 1

1. Lower the level or take the tuning fork of the sensor that has been removed out of the medium until the tuning fork is completely free.
 - ↳ If it is not possible to do this with the original medium, a medium of a similar density and viscosity must be used.
2. Check continuity between terminal 1 and 3.
 - ↳ The switching transistor must be switched through.



Note

If the switching transistor is locked, there is a fault in the safety path. The proof test has not been passed and must be aborted



Proof Test Procedure, Step 2

1. Raise the level or immerse the tuning fork of the sensor that has been removed into the medium until the tuning fork is fully covered.
 - ↳ Wait for the switching delay to elapse (1 s, unless ordered otherwise).
2. Check continuity between terminal 1 and 3.
 - ↳ The switching transistor must be locked.



Note

If the switching transistor is switched through, there is a fault in the safety path. The proof test has not been passed and must be aborted



Proof Test Procedure, Step 3

1. Re-install the sensor that was removed (optional).
 - ↳ Wait for power-up (10 s).
2. Restore the status OK by fully exposing the tuning fork.
 - ↳ Wait for the switching delay to elapse (1 s, unless ordered otherwise).
3. Check continuity between terminal 1 and 3.
 - ↳ The switching transistor must be switched through.



Note

If the switching transistor is locked, there is a fault in the safety path. The proof test has not been passed and must be aborted

7.4 Test Sequence B, Simulation with Test Button or Test Magnet on the Device

No change of level in the vessel is necessary for this sequence.

Note the following for the test sequences:

Test sequence B (simulation) is not permitted for a commissioning test.



Proof Test Procedure, Step 1

1. Check continuity between terminal 1 and 3.
↳ The switching transistor must be switched through.



Note

If the switching transistor is locked, there is a fault in the safety path. The proof test has not been passed and must be aborted.



Proof Test Procedure, Step 2

1. Press the test button or apply the test magnet.
↳ The device restarts (3 s).
If the button is pressed (or magnet applied) for a short period, the demand mode is maintained for 7 s afterwards.
If the button is pressed (or magnet applied) for a longer period, the demand mode is maintained as long as the button remains pressed or the test magnet is applied.
2. Check continuity between terminal 1 and 3.
↳ The switching transistor must be switched through.



Note

If the switching transistor is locked, there is a fault in the safety path. The proof test has not been passed and must be aborted.



Proof Test Procedure, Step 3

1. Release the test button or remove the test magnet.
↳ Wait for the switching delay to elapse (1 s, unless ordered otherwise).
2. Check continuity between terminal 1 and 3.
↳ The switching transistor must be switched through.



Note

If the switching transistor is locked, there is a fault in the safety path. The proof test has not been passed and must be aborted.

7.5 Verification Criterion

If one of the test criteria from the test sequences described above is not fulfilled, the device may no longer be used as part of a safety instrumented system.

- The purpose of proof-testing is to detect dangerous undetected device failures (λ_{du}).
- This test does not cover the impact of systematic faults on the safety function, which must be assessed separately.
- Systematic faults can be caused, for example, by process material properties, operating conditions, build-up or corrosion.
- As part of the visual inspection, for example, ensure that all of the seals and cable entries provide adequate sealing and that the device is not visibly damaged.

8 Repair and Fault Handling

8.1 Maintenance

Maintenance instructions and instructions regarding recalibration may be found in the manual pertaining to the device.



Note

Alternative monitoring measures must be taken to ensure process safety during configuration, proof-testing and maintenance work on the device.

8.2 Repair

Repair means restoring functional integrity by replacing defective components.

Components may be repaired/replaced by the customer's technical staff if **genuine spare parts** from Pepperl+Fuchs are used (they can be ordered by the end user) and the appropriate installation instructions are followed.



Note

A proof test must always be performed after every repair.

Spare parts are grouped into logical kits with the associated replacement instructions.

Document the repair with the following information:

- Serial number of the device
 - Date of the repair
 - Type of repair
 - Person who performed the repair
-



Note

Installation instructions are supplied with the original spare part and can also be accessed in the download area at www.pepperl-fuchs.com

Return the replaced component to Pepperl+Fuchs for fault analysis.

When returning the defective component, always enclose the **Declaration of Contamination** with the note **Used as SIL device in a safety instrumented system**.

For information on device returns, please see www.pepperl-fuchs.com.

8.3 Modification

Modifications are changes to SIL devices that are already delivered or installed.

- Modifications to SIL devices are usually performed from the manufacturer.
- Modifications to SIL devices onsite at the user's plant are possible following approval by the manufacturer.
- In this case, the modifications must be performed and documented by an Pepperl+Fuchs service technician.
- **Modifications to SIL devices by the user are not permitted.**

8.4 Decommissioning

When decommissioning, the requirements according to IEC 61508-1:2010 section 7.17 must be observed.

8.5 Disposal



If required by the Directive 2012/19/EU on waste electrical and electronic equipment (WEEE), the product is marked with the depicted symbol in order to minimize the disposal of WEEE as unsorted municipal waste. Do not dispose of products bearing this marking as unsorted municipal waste. Instead, return them to Pepperl+Fuchs for disposal under the applicable conditions.

8.5.1 Battery Disposal

- The end user is legally obliged to return used batteries.
- The end user can return old batteries or electronic assemblies containing these batteries free of charge to Pepperl+Fuchs.



In accordance with German law regulating the use of batteries (BattG §28 Para 1 Number 3), this symbol is used to denote electronic assemblies that must not be disposed of as household waste.

9 Appendix

9.1 Structure of the Measuring System

9.1.1 System Components

The measuring system's devices are shown in the following diagram (example).

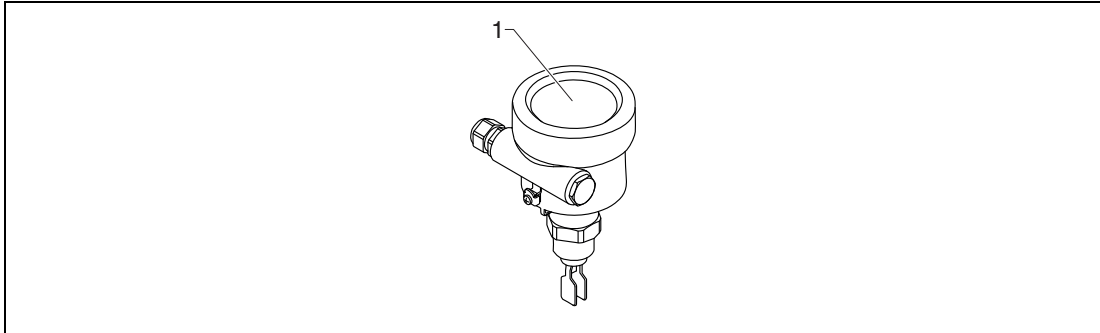

Figure 9.1 System components

1 Measuring device/sensor

9.1.2 Description of Application as a Safety Instrumented System

The sensor's tuning fork vibrates at its intrinsic frequency. The vibration frequency decreases as the density increases. This change in the frequency causes the current signal to change.

The switch point is in the range of the tuning fork and depends on the installation position.

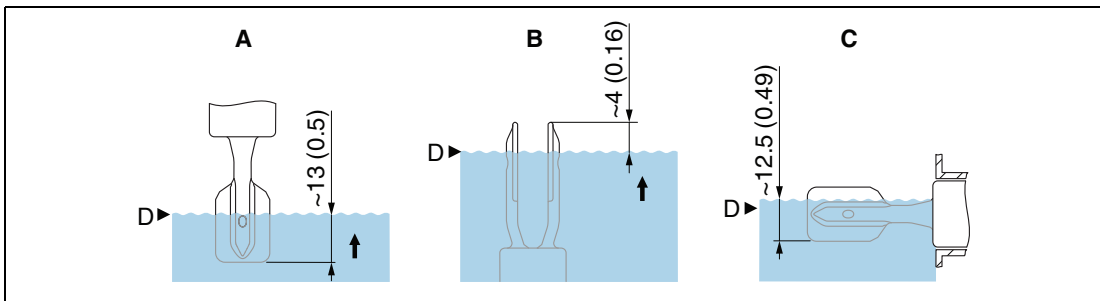

Figure 9.2 Switch point depending on the installation position, unit of measurement mm (inch)

- A Installation from above
- B Installation from below
- C Installation from the side
- D Switch point

- For information on the switch point under reference operating conditions, see the technical information.

Note

Correct installation is a prerequisite for safe operation of the device.



9.1.3 Measurement Function

Choice of operating modes:

- MIN detection

The measuring system is used to protect against a level that is too low (e. g. pump dry running protection, protection against emptying or protection against insufficient filling).

In normal operation, the tuning fork is covered by liquid and the measuring system reports the OK state. If the tuning fork is free, the device assumes the safe state and signals the demand mode.

- MAX detection

The measuring system is used to protect against a level that is too high (e. g. overflow prevention).

In normal operation, the tuning fork is not covered by liquid and the measuring system reports the OK state. If the tuning fork is covered, the device assumes the safe state and signals the demand mode.

Your automation, our passion.

Explosion Protection

- Intrinsic Safety Barriers
- Signal Conditioners
- FieldConnex® Fieldbus
- Remote I/O Systems
- Electrical Ex Equipment
- Purge and Pressurization
- Industrial HMI
- Mobile Computing and Communications
- HART Interface Solutions
- Surge Protection
- Wireless Solutions
- Level Measurement

Industrial Sensors

- Proximity Sensors
- Photoelectric Sensors
- Industrial Vision
- Ultrasonic Sensors
- Rotary Encoders
- Positioning Systems
- Inclination and Acceleration Sensors
- Fieldbus Modules
- AS-Interface
- Identification Systems
- Displays and Signal Processing
- Connectivity

Pepperl+Fuchs Quality
Download our latest policy here:

www.pepperl-fuchs.com/quality



71556606