

# Control Units Polyamide LRP\*

## Marking

Control Units, Polyamide LRP*
ATEX certificate: CML 16 ATEX 3009X ATEX marking:  II 2 GD Ex db eb ib mb IIC T* Gb Ex tb IIC T** °C Db T4/T130 °C @ Ta +55 °C T6/T80 °C @ Ta +40 °C on request
IECEx certificate: IECEx CML 16.0008X UKCA certificate: CML 22 UKEX 2550X

The \*-marked letters of the type code are placeholders for versions of the device.

Pepperl+Fuchs Group Lilienthalstraße 200, 68307 Mannheim, Germany
Internet: <a href="http://www.pepperl-fuchs.com">www.pepperl-fuchs.com</a>

## Target Group, Personnel

Responsibility for planning, assembly, commissioning, operation, maintenance, and dismantling lies with the plant operator.

The personnel must be appropriately trained and qualified in order to carry out mounting, installation, commissioning, operation, maintenance, and dismantling of the device. The trained and qualified personnel must have read and understood the instruction manual.

## Reference to Further Documentation

Observe laws, standards, and directives applicable to the intended use and the operating location. Observe Directive 1999/92/EC in relation to hazardous areas.

The corresponding datasheets, manuals, declarations of conformity, EU-type examination certificates, certificates, and control drawings if applicable (see datasheet) are an integral part of this document. You can find this information under [www.pepperl-fuchs.com](http://www.pepperl-fuchs.com).

In order to access this documentation, enter the product name, i. e. the type code, or the item number of the product in the search field of the website.

## Intended Use

The device is only approved for appropriate and intended use. Ignoring these instructions will void any warranty and absolve the manufacturer from any liability.

The control units are used to control electrical energy and electrical signals in hazardous areas. They must be installed in fixed installations. Intended use includes observing these operating instructions and the other applicable documents, e.g. the data sheet. Any other use of the control units is not allowed.

## Improper Use

Protection of the personnel and the plant is not ensured if the device is not used according to its intended use.

## Mounting and Installation

Observe the installation instructions according to IEC/EN 60079-14.

If you intend to install the device or enclosure in areas that may be exposed to aggressive substances, ensure that the stated surface materials are compatible with these substances. If required, contact Pepperl+Fuchs for further information.

During installation take into account all local / national or plant specific rules and regulations regarding electricity, grounding, installation as well as hygiene and safety.

Consider the requirements of the IEC/EN 60079-31 regarding excessive dust deposits.

Ensure that adequate free air exists around the enclosure, and that it is not subjected to external sources of heating that could affect the stated temperature class.

Safety-relevant markings are found on the nameplate supplied. Ensure that the nameplate is present and legible. Take the ambient conditions into account.

Additional warnings may be on separate labels besides the main nameplate.

The permitted ambient temperatures of the built-in components must not be exceeded.

Variants equipped with non-light transmitting control functions should be installed only in areas where the risk of mechanical impact is low.

Ensure that the enclosure is not damaged, distorted, or corroded.

Ensure that all seals are clean, undamaged, and correctly fitted.

Tighten all screws of the enclosure/enclosure cover with the appropriate torque.

Cover screws are designed to be self-captive and they should remain in the cover at all times. If they ever need to be replaced, they have to be screwed through the enclosure cover into the associated spacer.

For cable glands only use incoming cable diameters of the appropriate size.

Tighten all cable glands with the appropriate torque.

Close all unused cable glands with the appropriate sealing plugs.

Only use sealing plugs that are suitably certified for the application.

Close all unused enclosure holes with the appropriate stopping plugs.

Only use stopping plugs that are suitably certified for the application.

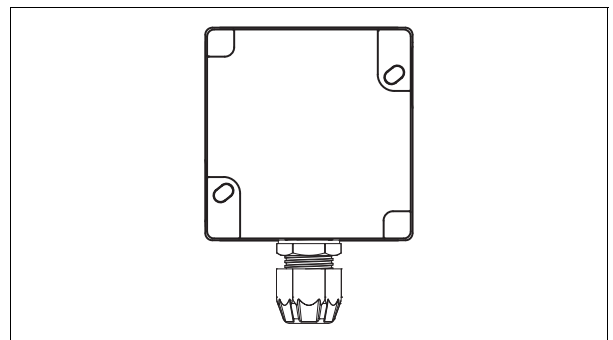

Enclosures are installed directly by using the screw holes in the enclosure rear.

Use all existing screw holes for mounting the enclosure.

It is recommended to use screws according to ISO 4762 or equivalent.

Follow below instructions when mounting the enclosure.



- (1) Mark the upper screw position on the mounting surface
- (2) Drill the appropriate screw hole into the mounting surface
- (3) Hang the enclosure using an appropriate screw in the upper thru-hole
- (4) Mark the lower screw position using the lower thru-hole
- (5) Remove enclosure
- (6) Drill the appropriate screw hole into the mounting surface for the lower thru-hole
- (7) Hang the enclosure using all available thru-holes
- (8) Tighten all mounting screws with the appropriate torque

**i Note**

Torque moments depend on the used screws and the material that they are screwed into.

If mounting the enclosure on concrete use expansion anchors. When mounting the enclosure to a steel framework use vibration resistant mounting material.

Make sure that the enclosure is mounted on a flat surface to avoid distortion of the enclosure and ensure proper sealing function of the cover gasket.

If external ground connections exist, ensure they are in good condition and are not damaged or corroded.

In order to prevent condensation in the enclosure, use suitably certified breather drains.

### Requirements for Cable Glands

Only use cable glands that are suitably certified for the application.

Only use cable glands with a temperature range appropriate to the application.

Only use cable glands with an ingress protection appropriate to the application.

Ground metal cable glands using either an internal earth continuity plate or external earth tag.

### Requirements for Internal Components

Select suitable conductors in order to ensure that the maximum permitted temperature of the conductors fit to the maximum permitted ambient temperature of the control station.

Select cables with a suitable temperature rating.

In case of mixed Ex e / Ex i arrangements, ensure the required minimum distances according to IEC/EN 60079-11.

Ensure that the terminals are in good condition and are not damaged or corroded.

Use only one conductor per terminal conductor entry point.

Observe the tightening torque of the terminal screws.

Use the shortest possible cable lengths and avoid small core cross sections.

Observe the minimum bending radius of the conductors.

When installing the conductors the insulation must reach up to the terminal.

When using stranded conductors, crimp wire end ferrules on the conductor ends.

Unused cables and connection lines must be either connected to terminals or securely tied down and isolated.

Insulation by tape alone is not permitted.

Observe the special conditions for safe use listed in the manufacturer's documentation.

Do not bunch more than 6 conductors in order to avoid hot spots.

Arrange ground connections for incoming and outgoing cables so that the earth fault current is not carried between separate grounding plates.

When installing additional components, consult Pepperl+Fuchs in order to ensure these components are listed in the EU-type examination certificate and the maximum power dissipation of this solution is within the allowed limits.

All normally closed contacts of the 2 pole and 4 pole contact blocks are designed as positive opening contacts according to IEC 60947.

For easier wiring the internal contact modules might be removed from the DIN-Rail. Take care the small notches of the modules fit into the cutouts of the rail when mounting them back on.

With ammeters for current transformer connection the interchangeable scales can be changed via an opening at the upper side.

### Rules for bringing in additional thru-holes for cable glands

In case of doubts contact Pepperl+Fuchs.

Thru-holes for plain entries must have a diameter of not more than 0.7 mm greater than the nominal diameter of the entry thread of cable gland or fitting.

Check the dimensional suitability of the selected entry device before installation.

Compact LRP\* enclosures can be drilled with a metric clearance entry for the maximum of a M25 cable gland. Use the center point marked in the drawing.

Flexible LRP\*L enclosures can be drilled with up to two metric clearance entries for the maximum of M25 cable glands. Observe the distance to enclosure rims as shown in the drawing.

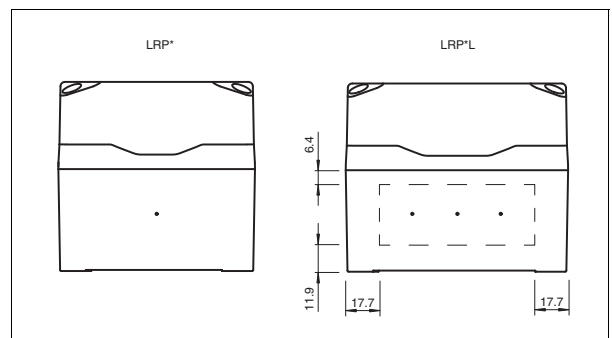

Calculate the minimum distance from the center of the additional thru-hole to the center of an already existing adjacent thru-hole by means of one of the following formulas:

1. Calculation via diameters HSN = diameter of adjacent thru-hole

HSA = diameter of additional thru-hole

Minimum distance between centers =  $1.5 \times (HSN+HSA)/2$

2. Calculation via widths across corners

WCN = width across corners of adjacent cable gland

WCA = width across corners of additional cable gland

Minimum distance between centers =  $1.2 \times (WCN+WCA)/2$

Fabricate the additional thru-holes with an appropriate tooling method.

Ensure the thru-hole diameters are fitting to the gaskets and cable glands to be installed.

Ensure the enclosure surfaces around the thru-holes are undamaged in order to maintain the IP-protection.

### Operation, Maintenance, Repair

Observe IEC/EN 60079-14 during operation.

Observe IEC/EN 60079-17 for maintenance and inspection.

Observe IEC/EN 60079-19 for repair and overhaul.

Before opening the enclosure make sure that the built-in components are de-energized.

When energized, the enclosure may only be opened for maintenance, if only intrinsically safe circuits are used inside the enclosure.

The required maintenance intervals depend on the respective application, ambient conditions and national regulations and therefore have to be determined by the user.

Labels, windows and other surfaces which are not protected against electrostatic discharge may be a potential electrostatic charge hazard and shall therefore be cleaned only with a damp cloth.

Before reassembly, make sure both gasket and sealing faces are in good and clean condition to assure the degree of protection.

If there is a defect, the device must be repaired by Pepperl+Fuchs.

Alternatively the device can be repaired by a qualified electrician in compliance with IEC/EN 60079-19.

### Delivery, Transport, Disposal

Check the packaging and contents for damage.

Check if you have received every item and if the items received are the ones you ordered.

The device, built-in components, packaging, and any batteries contained within must be disposed in compliance with the applicable laws and guidelines of the respective country.

### Technical Data

General	
Types and variants	LRP* - see type code table
Electrical specifications	
Operating voltage	400 V AC / DC max. See certification label
Operating current	16 A max. Dependent on terminals and equipment fitted, but must not exceed maximum. See certification label
Terminal capacity	2.5 mm <sup>2</sup>
Terminal torque	0.8 Nm
Mechanical specifications	
Dimensions	see data table
Enclosure cover	fully detachable
Cover fixing, torque	1.5 Nm
Degree of protection	IP66
Mass	see data table
Mounting	2x screws
Cable entry	cable glands as per specification
Material	
Enclosure	polyamide
Finish	inherent color black
Cover seal	one piece closed cell silicone
Cover fixing	M4 stainless steel combination Phillips and slotted screw
Grounding	2.5 mm <sup>2</sup> grounding terminal
Ambient conditions	
Ambient temperature	-40 ... 55 °C (-40 ... 131 °F) depending on integrated components -50 °C (-58 °F) on request
Data for application in connection with hazardous areas	
EU-Type Examination Certificate	CML 16ATEX3009X
Marking	 II 2 GD Ex db eb ib mb IIC T* Gb, Ex tb IIIC T** Db T4/T130 °C @ Ta +55 °C T6/T80 °C @ Ta +40 °C on request
Maximum power dissipation	Dependent on enclosure size See certification label
International approvals	
IECEX approval	IECEX CML 16.0008X
UKCA approval	CML 22 UKEX 2550X
Conformity	
Degree of protection	EN 60529
CE marking	0102

### Type Code / Model Number

1	2	3	4	5	6	7	8	9	10	11									
LR	*	*	.	*	.	***	.	***	.	***	.	***	.	***	.	*	.	.	*
LR	P	2	.	D	.	PGMX	.	E4MX	.	.	.	.	.	.	.	B	.	.	1

Example: LRP2.D.PGMX.E4MX.B.1

Control Unit, polyamide enclosure for two control functions, portrait orientation.

Upper function: pushbutton green, base-mounted contact block with 1x NO / 1x NC contacts.

Lower function: twist-to-release mushroom button, red, base-mounted contact block with 1x NO / 1x NC contacts.

Cable entry configuration: bottom face cable gland M20 polyamide. Type of protection Ex db eb and Ex tb.

1	Series
LR	control unit

2	Material
P	polyamide (PA)

3	Enclosure variant
1 ... 5L	enclosure size, see dimensions data table

4	Enclosure orientation
B	landscape
D	portrait

5	Function 1
xxx	see operating elements type code

6	Function 2
xxx	see operating elements type code

7	Function 3
xxx	see operating elements type code

8	Function 4
xxx	see operating elements type code

9	Function 5
xxx	see operating elements type code

10	Entry configuration / cable glands
A ... R	standard entry configurations, see cable entries table
X	no entries
Z	customized entries

11	Type of explosion protection
1	Ex db eb, Ex tb
3	Ex i*, Ex tb
5	mixed protection, e.g.: Ex db eb ib tb

## Variant-Specific Data - Dimensions and Enclosure Details

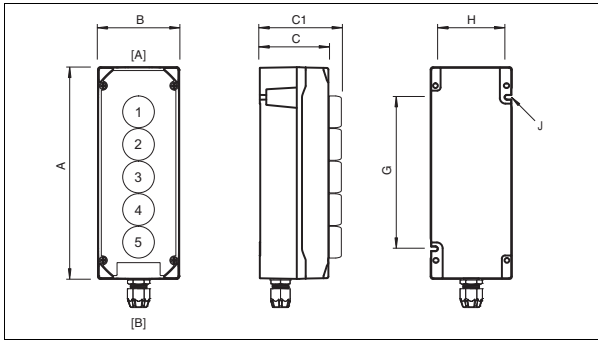

Enclosure type	Operating elements size and quantity	External dimensions [mm]				Mounting [mm]			Mass approx. [kg]
		A	B	C	C1	G	H	J	
LRP1.*	1x small / 1x large	90	88	85	134.5	50	72.5	5.6	0.7
LRP2.*	2x small	132	88	85	134.5	93	72.5	5.6	0.7
LRP2L.*	2x small / 1x large (4-pole)	160	100	85	134.5	97	88	5.6	0.9
LRP3.*	3x small	178	88	85	134.5	136	72.5	5.6	1
LRP5L.*	5x small / 2x large	260	100	85	134.5	186	88	5.6	1.2

Mass is valid for empty enclosure, it will increase according to enclosure accessories, integrated components and cable glands

Values might differ slightly due to manufacturing tolerances

Dimension C1 is maximum, it will differ according to operating elements configuration

## Cable Entries Quantity per Size

Type code	Cable entries Face A			Cable entries Face B		
	Quantity	Type	Clamping range	Quantity	Type	Clamping range
*.B.*	-	-	-	1	CG.PEDS1.M20.*	6 ... 12 mm
*.C.*	-	-	-	1	CG.PEDS1.M25.*	9 ... 17 mm
*.E.*	1	SP.PE.M20.*	-	1	CG.PEDS1.M20.*	6 ... 12 mm
*.F.*	1	SP.PE.M25.*	-	1	CG.PEDS1.M25.*	9 ... 17 mm

For further configurations please contact Pepperl+Fuchs