

Inertial Measurement Unit IMUF99*B16 with CANopen

Manual



With regard to the supply of products, the current issue of the following document is applicable:
The General Terms of Delivery for Products and Services of the Electrical Industry, published
by the Central Association of the Electrical Industry (Zentralverband Elektrotechnik und Elek-
troindustrie (ZVEI) e.V.) in its most recent version as well as the supplementary clause:
"Expanded reservation of proprietorship"

Worldwide

Pepperl+Fuchs Group
Lilienthalstr. 200
68307 Mannheim
Germany
Phone: +49 621 776 - 0
E-mail: info@de.pepperl-fuchs.com

North American Headquarters

Pepperl+Fuchs Inc.
1600 Enterprise Parkway
Twinsburg, Ohio 44087
USA
Phone: +1 330 425-3555
E-mail: sales@us.pepperl-fuchs.com

Asia Headquarters

Pepperl+Fuchs Pte. Ltd.
P+F Building
18 Ayer Rajah Crescent
Singapore 139942
Phone: +65 6779-9091
E-mail: sales@sg.pepperl-fuchs.com
<https://www.pepperl-fuchs.com>

1	Introduction.....	6
1.1	Content of this Document.....	6
1.2	Target Group, Personnel	6
1.3	Symbols Used	7
1.4	Intended Use	8
1.5	General Safety Notes.....	8
1.6	Declaration of Conformity.....	8
2	Product Description	9
2.1	Use and application.....	9
2.2	LED displays	11
2.3	Supported CANopen Functions	12
2.4	Accessories.....	13
3	Installation.....	14
3.1	Electrical connection.....	14
4	Cybersecurity Information.....	15
5	Commissioning.....	16
5.1	Commissioning via CANopen Engineering Tool.....	16
5.1.1	Change Transfer Rate and Node ID	16
5.1.2	Enable Processing of the Process Data.....	17
5.1.3	Restoring Factory Default Settings	17
5.1.4	Overview Measurement Variables Related Objects	18
5.1.5	Scaling Measurement Data	19
5.2	Filter Settings.....	20
5.3	Settings of Compensation Range	22
5.4	Application Flag	23
5.5	Gravity Flag	24
6	Parameterization Using the CANopen Engineering Tool with CANopen Objects	26
6.1	CANopen Overview.....	26
6.2	CANopen Object Directory	28
6.3	Object 0x1000 Device Type	31
6.4	Object 0x1001 Error Register	31
6.5	Object 0x1005 SYNC Identifier	31

6.6	Object 0x1008 Manufacturer Device Name	31
6.7	Object 0x1009 Manufacturer Hardware Version	32
6.8	Object 0x100A Manufacturer Software Version	32
6.9	Object 0x1010 Store Parameters.....	32
6.10	Object 0x1011 Restore Default Parameters	32
6.11	Object 0x1017 Producer Heartbeat Time.....	32
6.12	Object 0x1018 Device ID (Identity Object)	33
6.13	Object 0x1200 Server SDO Parameter (Default SDO)	33
6.14	Object 0x1800 TPDO1 Communication Parameter - Inclination CiA Profile 410.....	34
6.15	Object 0x1804 TPDO5 Communication Parameter - Acceleration	35
6.16	Object 0x1805 TPDO6 Communication Parameter - Rotation Rate	35
6.17	Object 0x1806 TPDO7 Communication Parameter - Rotational Acceleration Rate.....	36
6.18	Object 0x1807 TPDO8 Communication Parameter - Gravity Vector.....	36
6.19	Object 0x1808 TPDO9 Communication Parameter - Linear Acceleration.....	37
6.20	Object 0x1809 TPDO10 Communication Parameter - PF Angle	37
6.21	Object 0x180A TPDO11 Communication Parameter - Euler Angle	38
6.22	Object 0x180B TPDO12 Communication Parameter - Quaternion	38
6.23	Object 0x180C TPDO13 Communication Parameter - Temperature.....	39
6.24	Object 0x1A00 TPDO1 Mapping - Inclination CiA Profile 410.....	39
6.25	Object 0x1A04 TPDO5 Mapping - Acceleration.....	39
6.26	Object 0x1A05 TPDO6 Mapping - Rotation Rate	40
6.27	Object 0x1A06 TPDO7 Mapping - Rotational Acceleration Rate	40
6.28	Object 0x1A07 TPDO8 Mapping - Gravity Vector	40
6.29	Object 0x1A08 TPDO9 Mapping - Linear Acceleration.....	40
6.30	Object 0x1A09 TPD10 Mapping - Euler Angle	41
6.31	Object 0x1A0A TPD11 Mapping - PF Angle	41
6.32	Object 0x1A0B TPD12 Mapping - Quaternion	41
6.33	Object 0x1A0C TPD13 Mapping - Temperature	41
6.34	Object 0x2000 Acceleration Data	42
6.35	Object 0x2001 Acceleration Scaling/Offset.....	42

6.36	Object 0x2002 Rotation Rate Data	42
6.37	Object 0x2003 Rotation Rate Scaling/Offset.....	42
6.38	Object 0x2004 Rotational Acceleration Data	42
6.39	Object 0x2005 Rotational Acceleration Scaling/Offset.....	43
6.40	Object 0x2006 Gravity Vector Data	43
6.41	Object 0x2007 Gravity Vector Scaling/Offset.....	43
6.42	Object 0x2008 Linear Acceleration Data	43
6.43	Object 0x2009 Linear Acceleration Scaling/Offset.....	43
6.44	Object 0x200A PF Angle Data.....	44
6.45	Object 0x200B Euler Angle Data	44
6.46	Object 0x200C Angle Configuration	45
6.47	Object 0x200D Quaternion Data.....	46
6.48	Object 0x200E Quaternion Scaling/Offset	46
6.49	Object 0x200F Temperature Data	46
6.50	Object 0x2010 Temperature Scaling/Offset.....	46
6.51	Object 0x2100 Filter Setup Acceleration.....	46
6.52	Object 0x2101 Filter Setup Rotation Rate	47
6.53	Object 0x2102 Filter Setup Gravity Vector and Angle.....	47
6.54	Object 0x2103 Filter Setup Linear Acceleration	47
6.55	Object 0x2104 Filter Setup Rotational Acceleration Rate	48
6.56	Object 0x2105 Acceleration Application Flags (AF)	48
6.57	Object 0x2106 Rotation Rate Application Flags (AF).....	52
6.58	Object 0x2107 Inclination Application Flags (AF).....	56
6.59	Object 0x2200 Application Tag	60
6.60	Object 0x2201 PF Serial Number	60
6.61	Object 0x6000 Resolution.....	60
6.62	Object 0x6010 Slope Long16.....	61
6.63	Object 0x6011 Slope Long16 Operating Parameter.....	61
6.64	Object 0x6020 Slope Lateral16	61
6.65	Object 0x6021 Slope Lateral16 Operating Parameter.....	61
6.66	Object 0x6511 Device Temperature	61

1 Introduction

1.1 Content of this Document

This document contains information required to use the product in the relevant phases of the product life cycle. This may include information on the following:

- Product identification
- Delivery, transport, and storage
- Mounting and installation
- Commissioning and operation
- Maintenance and repair
- Troubleshooting
- Dismounting
- Disposal



Note

For full information on the product, refer to the further documentation on the Internet at www.pepperl-fuchs.com.



Note

For specific device information such as the year of construction, scan the QR code on the device. As an alternative, enter the serial number in the serial number search at www.pepperl-fuchs.com.

The documentation comprises the following parts:

- This document
- Datasheet

In addition, the documentation may comprise the following parts, if applicable:

- EU-type examination certificate
- EU declaration of conformity
- Attestation of conformity
- Certificates
- Control drawings
- Instruction manual
- Functional safety manual
- Other documents

1.2 Target Group, Personnel

Responsibility for planning, assembly, commissioning, operation, maintenance, and dismantling lies with the plant operator.

Only appropriately trained and qualified personnel may carry out mounting, installation, commissioning, operation, maintenance, and dismantling of the product. The personnel must have read and understood the instruction manual and the further documentation.

Prior to using the product make yourself familiar with it. Read the document carefully.

1.3 Symbols Used

This document contains symbols for the identification of warning messages and of informative messages.

Warning Messages

You will find warning messages, whenever dangers may arise from your actions. It is mandatory that you observe these warning messages for your personal safety and in order to avoid property damage.

Depending on the risk level, the warning messages are displayed in descending order as follows:



Danger!

This symbol indicates an imminent danger.

Non-observance will result in personal injury or death.



Warning!

This symbol indicates a possible fault or danger.

Non-observance may cause personal injury or serious property damage.



Caution!

This symbol indicates a possible fault.

Non-observance could interrupt the device and any connected systems and plants, or result in their complete failure.

Informative Symbols



Note

This symbol brings important information to your attention.



Action

1. This symbol indicates a paragraph with instructions. You are prompted to perform an action or a sequence of actions.

1.4 Intended Use

The Inertial Measurement Unit IMUF99*B16, with the F99-Fusion technology, is optimized to provide gyroscopic stabilized inclination and acceleration data as well as rotation rate data.

Read through this manual carefully. Familiarize yourself with the device before installing, mounting, or operating.

Always operate the device as described in these instructions to ensure that the device and connected systems function correctly. The protection of operating personnel and the plant is guaranteed only if the device is operated in accordance with its intended use.

Note



Correct Usage in Applications

The sensor can be used in complex structures and applications, such as implementations in bus networks and machines where specific control routines are used on customer side. It is recommended to process measured data according to the rules of measurement engineering and control theory. It is further recommended to derive adequate measures for the specific application.

1.5 General Safety Notes

Responsibility for planning, assembly, commissioning, operation, maintenance, and dismantling lies with the plant operator.

Installation and commissioning of all devices may be performed only by trained and qualified personnel.

The device is only approved for appropriate and intended use. Ignoring these instructions will void any warranty and absolve the manufacturer from any liability.

If serious faults occur, stop using the device. Secure the device against inadvertent operation. In the event of repairs, return the device to your local Pepperl+Fuchs representative or sales office.

Note



Disposal

Electronic waste is dangerous. When disposing of the equipment, observe the current statutory requirements in the relevant country of use and local regulations.

1.6 Declaration of Conformity

This product was developed and manufactured in line with the applicable European standards and directives.

Note



A declaration of conformity can be requested from the manufacturer.

The product manufacturer, Pepperl+Fuchs Group, 68307 Mannheim, Germany, has a certified quality assurance system that conforms to ISO 9001.



ISO9001

2 Product Description

2.1 Use and application

The IMUF99, Inertial Measurement Unit, combines an acceleration sensor and a gyroscope into a single device and links the two sensor elements to increase overall performance of the system and open up new possibilities. This device is optimized to provide gyroscopic-stabilized inclination and acceleration data as well as rotation rate data.

Heart of the IMU is the adaptive sensor fusion algorithm. It is developed and implemented for inclination measurement with extreme effective compensation of external acceleration disturbance.

Triaxial acceleration sensor and triaxial gyroscope outputs are used as input of the fusion system. The adaptive sensor fusion algorithm is designed to compensate the measurement errors by combining accelerometer and gyroscope data adaptively to the current situation.

The following figures show the orientation and assignment of the axis for which the sensor can be used depending on the parameterization of the angle output system.

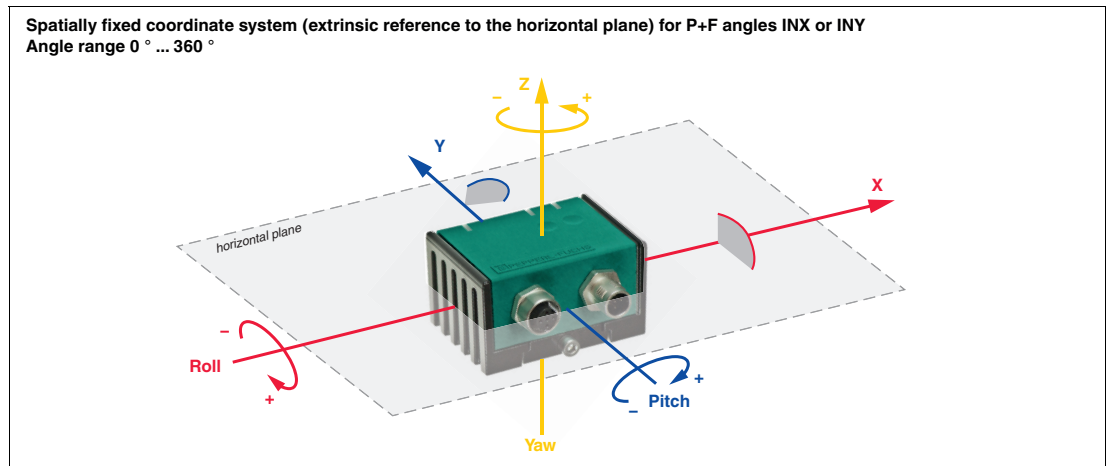

Figure 2.1

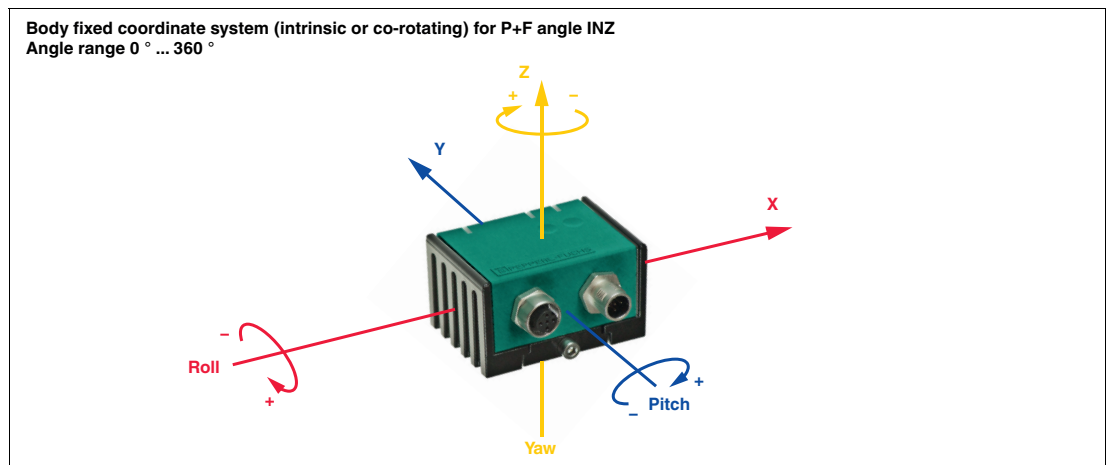

Figure 2.2

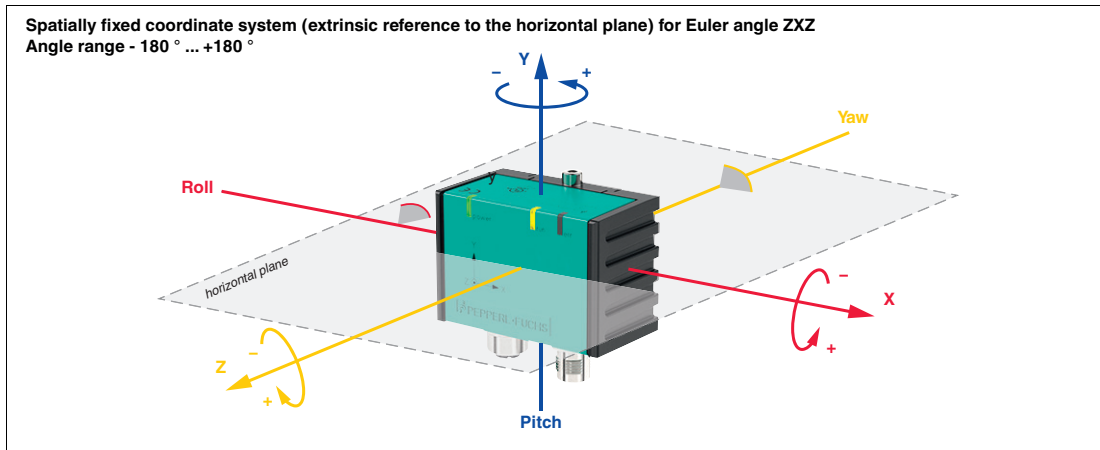

Figure 2.3

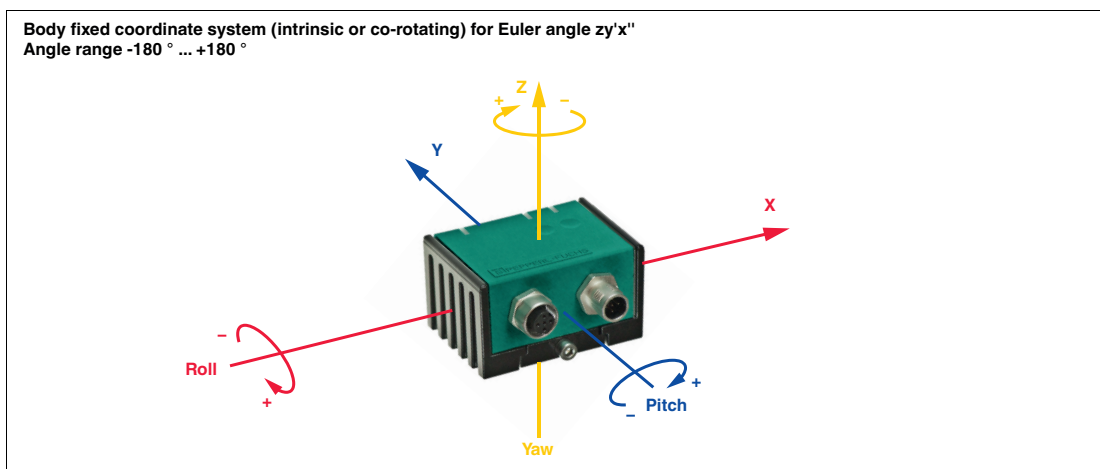

Figure 2.4

Gravity Flag

The IMU measures the acceleration, yaw rate and angle in each of 3 axis. Regardless of the current position of the sensor in space, the acceleration and yaw rate values = rotation rate values are always reliably available. A reliable angle output per measuring axis depends on the current position of the sensor in space.

A change in angle around the gravitational vector, which is always vertical, cannot be measured. If a measuring sensor axis is parallel to the gravitational vector ($\pm 5^\circ$), then this axis does not provide reliable angle values and must be ignored. The Gravity Flag (GF) offers help for this. The sensor automatically detects whether a sensor axis is parallel to the gravitational vector and shows this in the status of the Gravity Flag (GF). Accordingly, it is always displayed for each angle value as to whether it can be used.

Application Flag

Independent limits can be set for the X-, Y- and Z-axes of the acceleration, rotation rate and angle measurement axis. If these limits are exceeded, this is indicated in the switching status of the Application Flags (AF). The Objects 0x2105 to 0x2107 are used to set the application flags (AF). The status of the application flag (AF) is displayed in the 7th byte of TPDO5 for acceleration, TPDO6 for rotation rate, TPDO10 for PF Angle and TPDO11 for Euler Angle.

Selectable output values

To allow you to perfectly adapt the measuring system to your application, there are several selectable output values such as acceleration, rotational speed, inclination (Euler angle, Euler value, quaternions) and programmable filters.

Parameterization and data transfer take place via the integrated CANopen interface.

In the following figure the signal path of input and output values is illustrated.

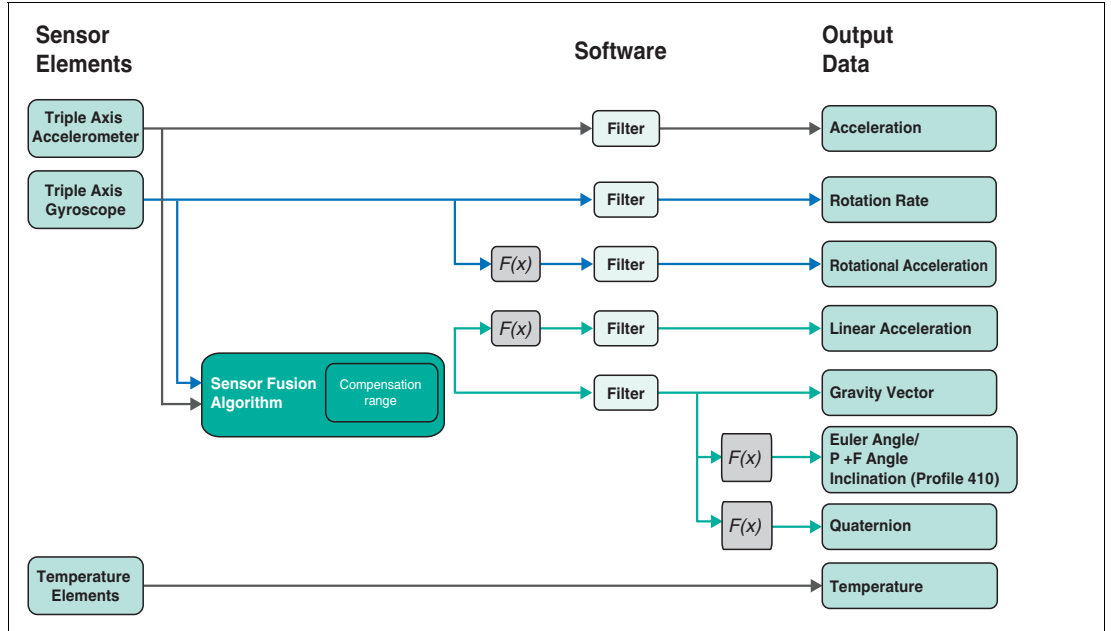

Figure 2.5

2.2 LED displays

The IMU360D-F99 has three LED indicators that allow rapid visual monitoring. They provide status and fault indication, run (green) and error (red) LED behave according to CiA 303-3.

- The yellow **power** LED indicates the state of the power supply
- The green **run** LED indicates the CANopen state
- The red **err** LED indicates an error

LED	State	Description
Yellow: power	On	Voltage ok
	Off	No power or sensor defect
Green: run	Flickering	The device is unconfigured (node ID: 255) Ready for LSS configuration (flashing frequency 10 Hz)
	Blinking	The device is in the NMT state "Pre-Operational". (Flashing frequency 2.5 Hz)
	Single flash	The device is in the NMT state "Stopped"
	On	The device is in the NMT state "Operational"
Red: err	On	The device is in the state "CAN Bus Off"
	Single flash	The CAN controller error counter has reached or exceeded its warning limit
	Off	The device is operating without errors

Table 2.1

2.3 Supported CANopen Functions

The device has a standardized CANopen interface in accordance with the CiA301 specification. All usable CANopen objects of the object directory OV are listed in this manual.

You can set the node ID and baud rate via LSS.

You can set the transmission speed in increments of 125 kbit/s up to 1 Mbit/s, according to CiA 102, Table 1 and CiA 301 5.4, Table 1. We support transmission speeds of 125, 250, 500 and 1000 kbit/s. The maximum cable length for 1 Mbit/s must be 30 m.

Note

An EDS configuration file is available for easy integration and parameterization of the sensor. You can download it from www.pepperl-fuchs.com, on the product page for the IMUF99*B16*.

Note

This device does not have an internal terminator. If required, this can be implemented externally via a T-piece at the end of the bus (120 ohms).

Available CANopen Functions

- Transmit Process data objects (TPDO)
- Service data object (SDO)
- Heartbeat monitoring mechanism
- Layer settings service (LSS) for setting the node ID and baud rate
- Save and recovery function (store and load parameter field)
- Status and fault indicator (run and error LED according to CiA 303-3)
- Device Profile CIA 410

Manufacturer-specific properties and functions

- Application-specific tag
- Synchronization function for CANopen sensors

The IMUF99*B16* sensors support the following modes of operation:

- Cyclic operation: The TPDO is sent cyclically every 10 ms. The sensor accepts event-driven modes FEh and FFh. Cyclic time is adjustable via
 - Event-Timer (Maximum time between TPDO transmission)
 - Inhibit-Timer (Minimum time between TPDO transmission)
- SYNC operation: The TPDO is sent after receiving a synchronization message (SYNC) every n SYNCs (n = 1...240). The sensor accepts synchronous modes 00-F0h.

2.4 Accessories

Various accessories are available. See datasheet or relevant product page on the Internet www.pepperl-fuchs.com.

Designation	Description
EDS file	An EDS configuration file is available for easy integration and parameterization of the sensor. You can download it from www.pepperl-fuchs.com , on the product page for the IMUF99*B16*.
CAN/USB Configuration Kit	<p>Configuration kit for communications between FDT frame application and CANopen Sensor.</p> <p>Includes the following components:</p> <ul style="list-style-type: none"> • CAN/USB Converter-SUBD9 • Power supply for CAN/USB converter-SUBD9 • Connection cable and adapter cable for components <p>There is a CANopen Parameterization Tool available to download from the product page of the configuration kit. This software bundle contains the VCI driver for the CAN/USB converter-SUBD9, the DTM for CANopen communication for CAN communication with PACTware/PACTwareDC and the PACTware/PACTwareDC.</p>
V15S-TR-CAN/DN-120R	Terminator for DeviceNet, CANopen

3 Installation

3.1 Electrical connection

The IMUF99PL-* is equipped with 2 connectors M12 x 1, 5-pin, male and female for CAN bus integration. If a terminator is required, it must be attached externally on the female connector. Therefore e. g. "Terminator ICZ-TR-CAN/DN-V15" from Pepperl+Fuchs is available (also see datasheet of the sensor).

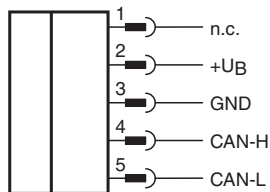

Pin	Wire color	Designation
1	Brown	Not used
2	White	+UB
3	Blue	GND
4	Black	CAN-H
5	Gray	CAN-L

Table 3.1 Connector assignment



Note

The wire colors listed above apply when one of the bus cables from the Pepperl+Fuchs accessories range is used.



Note

The device complies with the EMC norms and standards described in the datasheets. If necessary, additional external EMC protection elements and interference suppression measures (e.g. filters) are recommended.



Warning!

Damage to the device

Connecting an alternating current or excessive supply voltage can damage the device or cause the device to malfunction.

Electrical connections with reversed polarity can damage the device or cause the device to malfunction.

Connect the sensor to direct current (DC). Ensure that the supply voltage rating is within the specified sensor range. Ensure that the connecting wires on the cordset in use are connected correctly.



Connecting the sensor to the voltage

1. Connect the operating voltage to pins 2 and 3 of the 5-pin connector.
↳ The "Power" LED lights up yellow.

4 Cybersecurity Information

Security context

The device is designed for use in an industrial CAN bus network such as in mobile equipment. The plant operator must ensure that the device is physically protected against unauthorized access.

In addition, it must also be ensured that only well-known and trusted bus nodes are connected in the CAN bus network.

Decommissioning

Only adjustable parameter data are permanently saved. Parameter data can be deleted by restoring factory settings, but operating time data cannot be deleted. In case of doubt, the device must be physically destroyed to ensure these data are also destroyed.

5 Commissioning

5.1 Commissioning via CANopen Engineering Tool



Note

Before commissioning the sensor on a CAN bus, check whether the communication parameters of the sensor match your CANopen network. The factory default settings are a transfer rate of 250 kbit/s and a node ID of 16. If the node ID is already assigned or not desired and a different transfer rate is required, you can change these settings.



Basic commissioning steps

1. Connect the sensor to the CAN bus and ensure a 24 V DC electric power supply.
2. If necessary, change the communication parameters of the sensor using a suitable CANopen Engineering Tool.
3. For correct communication, make sure that a terminator and at least one other device are connected to the CAN bus. A monitoring tool is also sufficient.
 - ↳ The green LED flashes and the sensor is in the "Pre-operational" state. The sensor sends the heartbeat message with the CAN identifier 0x700+Node-ID (default 0x710). You can now parameterize the sensor using service data objects (SDOs).
 - ↳ If communication conditions are faulty, the red LED flashes and the sensor is in the "Error-passive" state.



Note

The following sections describe basic parameterization settings for commissioning, operation, diagnosis, and restoring to factory settings.

5.1.1 Change Transfer Rate and Node ID



Change the transfer rate (baud rate) and the node ID using the following steps:

1. The sensor can be found by the Manufacturer ID and product code (see object 0x1018) using a classic LSS scan. If the sensor has node ID 255, an LSS fast scan can also be used. This is shown by the rapid flashing of the status LED.
2. If the sensor is found, set it in LSS configuration mode either with the "Switch state selective" service or all devices with the "Switch state global configuration" service.
3. Now set the required node ID and baud rate.
4. Save the new values as persistent objects using the "Store configuration" service.
5. Send an NMT reset command to the sensor to activate the node ID.
 - ↳ The baud rate will be active after a successful "Activate bit timing" LSS service.

5.1.2 Enable Processing of the Process Data

To enable the sensor to send/receive process data, you must set the sensor to the Operational state using an NMT Main Device in accordance with CiA 301.

The fix mapping of the process data is specified in the respective TPDO mapping parameter. Here, the available objects are coded in the various subindices. The process data sequence corresponds to the subindices sequence.

Example: The process data (TPDO1) is mapped as follows:

Byte 0	Byte 1	Byte 2	Byte 3	Byte 4	Byte 5	Byte 6	Byte 7
Device temperature byte 0 LSB	Device temperature byte 1 MSB	Slope long16 byte 0 X-axis value LSB	Slope long16 byte 1 X-axis value MSB	Slope lateral16 byte 0 Y-axis value LSB	Slope lateral16 byte 1 Y-axis value MSB		

Table 5.1

TPDO5-TPDO13 are deactivated by default (COB ID 0x80000000). In order to activate them a network unique CAN identifier has to be assigned and the invalid bit 31 has to be set to 0. The mapping of all TPDOs is static and cannot be changed.

5.1.3 Restoring Factory Default Settings



You can restore the sensor's factory settings using index 0x1011 "Restore default parameters":

1. Write the signature "load" 0x64616F6C in object 0x1011:1 of the sensor.
2. Switch off the voltage supply to the sensor and then switch it on again (power cycle).
3. Alternatively, you can also trigger a NMT Node Reset.

↳ The sensor's factory settings are now restored.

5.1.4 Overview Measurement Variables Related Objects

The following table shows an overview about all available measurement values that is provided by sensor. Additional it shows which objects can be used for configuration.

Measured variable	Measurement data	Filter setting	Angle setting	Application flag setting	Scaling and offset setting	Unit	TPDO
Inclination (Profile 410)	0x6010 (X-axis) 0x6020 (Y-axis)	0x2102	0x6011 0x6021 0x200C:0x04	–	0x6000	° [deg] Default setting: 0.01°	TPDO1
Temperature (Profile 410)	0x6511	–	–	–	–	°C	TPDO1
Acceleration	0x2000	0x2100	–	0x2105	0x2001	g	TPDO5
Rotation Rate	0x2001	0x2101	–	0x2106	0x2003	°/sec	TPDO6
Rotation Rate Acceleration	0x2004	0x2104	–	–	0x2005	°/sec ²	TPDO7
Gravity Vector	0x2006	0x2102	–	–	0x2007	g	TPDO8
Linear Acceleration	0x2008	0x2103	–	–	0x2009	g	TPDO9
PF Angle	0x200A With <ul style="list-style-type: none"> • Application Flag • Gravity Flag 	0x2102	0x200C	0x2107	0x200C	° [deg]	TPDO10
Euler Angle	0x200B With Gravity Flag	0x2102	0x200C	–	0x200C	° [deg]	TPDO11
Quaternion	0x200D	0x2102	–	–	0x200E	–	TPDO12
Temperature	0x200F	–	–	–	0x2010	°C	TPDO13

5.1.5 Scaling Measurement Data

The following table gives an overview of output data of objects and for scaling the various measured variables. The output data are mapped into the following TPDOs.

Each measured variable can be scaled with this:

$$(Data_internal - Offset) / Factor = Output_Data [unit]$$

Measured variable	Measurement data	Scaling and offset setting	Unit (accord. to scaling)	TPDO
Inclination (Profile 410)	0x6010 (X-axis) 0x6020 (Y-axis)	0x6000	0.01° [deg]	TPDO1
Acceleration	0x2000	0x2001	g	TPDO5
Rotation Rate	0x2002	0x2003	°/sec	TPDO6
Rotation Rate Acceleration	0x2004	0x2005	°/sec ²	TPDO7
Gravity Vector	0x2006	0x2007	g	TPDO8
Linear Acceleration	0x2008	0x2009	g	TPDO9
PF Angle	0x200A	0x200C	° [deg]	TPDO10
Euler Angle	0x200B	0x200C	° [deg]	TPDO11
Quaternion	0x200D	0x200E	–	TPDO12
Temperature	0x200F	0x2010	°C	TPDO12



Note

Note that the unit factor is dependent on scaling and offset setting.

The following example for "Acceleration" shows how to modify the scaling for the output data.

For example:

Data_internal = 970

Object 0x2001 (Scaling and offset setting)

- Subindex 0x01: Factor = 1000
- Subindex 0x02: Offset = 0

Object 0x2000 (Measurement data)

$$(970 - 0) / 1000 = 0.97 [g]$$

5.2 Filter Settings

Using one of the following filter types, filters in the signal path can be activated in such a way that vibration frequencies that excite the sensor are suppressed. These vibrations could be triggered by a running engine or gearbox, for example. In this way, the quality of the angle output can be adjusted despite disturbing vibrations. The filter type, the filter order and the width of a low-pass filter can be set.

Measured variable	Measurement data	Filter setting	TPDO
Inclination (Profile 410)	0x6010 (X-axis) 0x6020 (Y-axis)	0x2102	TPDO1
Acceleration	0x2000	0x2100	TPDO5
Rotation Rate	0x2002	0x2101	TPDO6
Rotation Rate Acceleration	0x2004	0x2104	TPDO7
Gravity Vector	0x2006	0x2102	TPDO8
Linear Acceleration	0x2008	0x2103	TPDO9
PF Angle	0x200A	0x2102	TPDO10
Euler Angle	0x200B	0x2102	TPDO11
Quaternion	0x200D	0x2102	TPDO12

The filter setting needs a filter type, filter order and a cut-off frequency to operate as a low-pass filter. This could be one of the following items:

Filter Types	ID
Butterworth lowpass	0
Butterworth highpass	1
Bessel lowpass	2
Bessel highpass	3
Tschebyscheff lowpass	4
Tschebyscheff highpass	5

Table 5.2

Filter Order	ID
Off	0
1 st	1
2 nd	2
3 rd	3

Table 5.3

Cut-off frequency	ID
1 ... 65000 mHz	1 ... 65000

Table 5.4

Example

The following example of "PF Angle" shows to change the filter settings for output data.

Object 0x2102

- Subindex 0x01: Type = 0 is buttworworth lowpass filter
- Subindex 0x02: Order = 0 is filter order 1st
- Subindex 0x03: cut-off frequency = 50000 is 50 Hz

Object 0x2102

The PF Angle measurement data tends to be more robust to value changes at vibration frequencies above 50 Hz.

5.3 Settings of Compensation Range

The object "Compensation Range" (0x200C:4) is used to adjust the quality of the angle output, depending on the application-specific motion profile. In principle, external accelerations, shocks and jerky movements can lead to incorrect angle outputs. This object must be selected before the actual angle measurement.

Physical correlations:

- The quality of the angular stability always depends on the specific application.
- Large external mechanical shocks such as a large amplitude or a small frequency lead to some angular deviation.
- Large external mechanical shocks such as a large amplitude or a small frequency lead to some angular deviation.

The choice of the optimal parameter value for the compensation range must be made based on the types of movement most commonly encountered in the application. In doing so, a balance must be struck between a shock-lasting (e.g. pothole or bump) and a driving profile with predominantly sustained linear acceleration (linear over several seconds).

The object can be set to one of the values 0, 1, 2, ... 7. The following table shows the selection options for the different object values and how well they are suitable for either "shock-heavy" or "linear acceleration-heavy" motion profiles in the application. The smaller the value selected, the faster the quality of the angle measurement recovers after a major shock situation. The larger the value selected, the longer the quality of the angle measurement can be maintained during a linear acceleration run.



Value compensation range	Angular drift compensation after a large amplitude shock		Angular drift compensation against sustained linear acceleration	
0	+++++++	Preferable	+	Barely
1	+++++++		++	
2	+++++		+++	
3	++++		++++	
4	+++		+++++	
5	++		+++++	
6	+		+++++	
7	+	Barely	+++++++	Preferable

Table 5.5

The object value can only be changed when the sensor is at rest, since the "Pre-Operational mode" has to be activated and deactivated again for this. When leaving the "Pre-Operational mode" the sensor reinitializes itself, which requires a static rest position (without external accelerations).

5.4 Application Flag²⁰²⁴

Independent limits can be set for the X-, Y- and Z-axes of the acceleration, rotation rate and angle measurement axes. If these limits are exceeded, this is indicated in the switching status of the application flags (AF).

The Objects 0x2105 ... 0x2107 are used to set the application flags (AF). The status of the application flag (AF) is displayed in the 7th byte of the following TPDOs:

- TPDO5 for acceleration
- TPDO6 for rotation rate
- TPDO10 for PF Angle
- TPDO11 for Euler Angle

The following table shows how the AF status can be interpreted based on the PDO content for each measured value.

Content Byte 7 HEX	Content Byte 7 Binary	Z-Application Flag	Y-Application Flag	X-Application Flag
00	000	Not active	Not active	Not active
01	001	Not active	Not active	Active
02	010	Not active	Active	Not active
03	011	Not active	Active	Active
04	100	Active	Not active	Not active
05	101	Active	Not active	Active
06	110	Active	Active	Not active
07	111	Active	Active	Active

Table 5.6

5.5 Gravity Flag

Rotations about the gravity vector cannot be detected in the angle output.

Technical-physical relations

- Regardless of the mounting position of the sensor, a rotation around the gravitational vector is not recognized as an angle change.
- If the mounting position or a previous movement of the application causes its measuring axis to be parallel ($\pm 5^\circ$) to the earth's gravitational vector, then this measuring axis shows a noisy behavior both in the idle state and during movements around the gravitational vector.



Note

This effect only refers to the output of the angle values. Acceleration and rotation rate values are unaffected by this effect.

For these reasons, the sensor offers the functionality that this condition is automatically detected and displayed. The sensor thus automatically recognizes whether and which measuring axis is parallel to the gravitational vector and displays this via a flag.

The status of the Gravity Flag is displayed in the 8th byte of TPDO10 for PF Angle and TPDO11 for Euler Angle.

Measured variable	Measurement data	TPDO
PF Angle	0x200A (with Gravity Flag)	TPDO10 (Gravity Flag in 8th byte)
Euler Angle	0x200B (with Gravity Flag)	TPDO11 (Gravity Flag in 8th byte)

Table 5.7

The content of byte 8 can assume the following values with the appropriate meaning.

Content Byte 8 HEX	Content Byte 8 Binary	X-Gravity Flag	Y-Gravity Flag	Z-Gravity Flag	Description
00	000	Not active	Not active	Not active	No measuring axis currently parallel to the gravitational vector
01	001	Active	Not active	Not Active	The x-axis (Roll) is currently parallel to the gravitational vector
02	010	Not active	Active	Not active	The y-axis (Pitch) is currently parallel to the gravitational vector
04	100	Not Active	Not active	Active	The z-axis (Yaw) is currently parallel to the gravitational vector

Table 5.8

The following 2 examples show the value of Gravity Flag for different sensor orientations.

Y-Axis Parallel to Gravity Vector

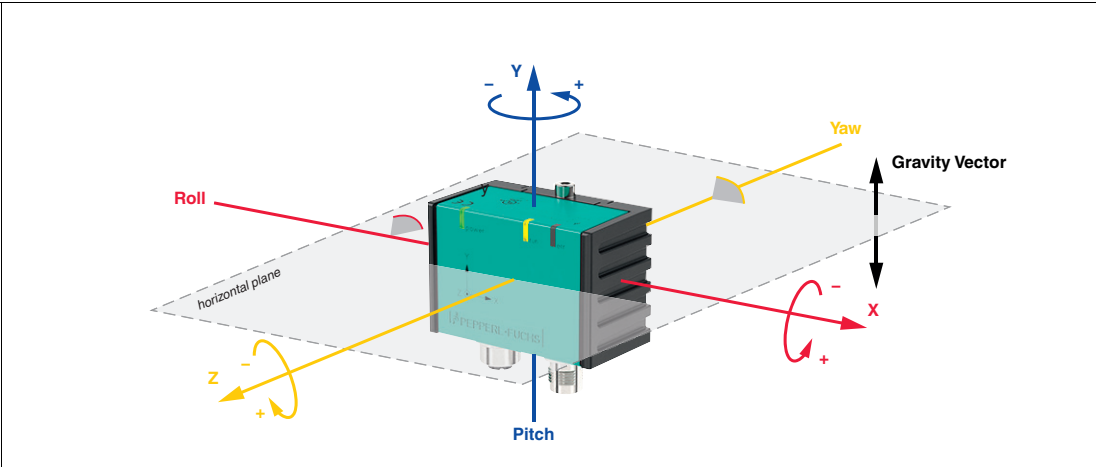

Figure 5.1

Object 0x200A

0x200A:4 = 0x*2

*value of Application Flag which is part of 0x200A:4

Z-Axis Parallel to Gravity Vector

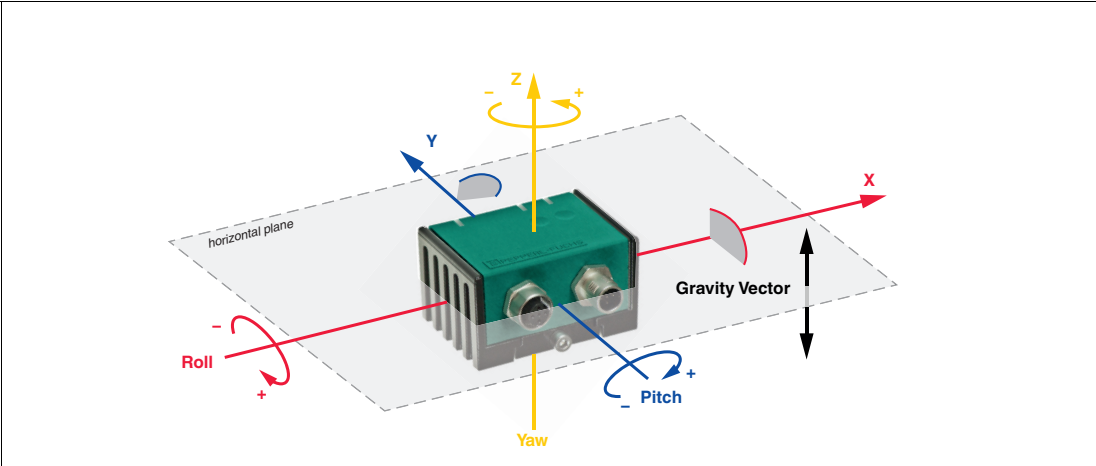

Figure 5.2

Object 0x200A

0x200A:4 = 0x*4

*value of Application Flag which is part of 0x200A:4

6 Parameterization Using the CANopen Engineering Tool with CANopen Objects

6.1 CANopen Overview

What Is CANopen?

CANopen is a multimaster-compliant fieldbus system based on the CAN (**C**ontroller **A**rea **N**etwork).

Devices on the CAN fieldbus communicate via message identifiers rather than via addresses. This allows all devices to access the fieldbus at any time. Fieldbus access is according to the CSMA/CA principle (**C**arrier **S**ense **M**ultiple **A**ccess / **C**ollision **A**voidance).

Collision Avoidance means that the dominant signal "0" overwrites the recessive signal "1" in the event of simultaneous access. The node that sends the "1" detects this and aborts the data transfer. As a result, messages with a lower identifier have higher priority and messages with higher priority are not interrupted by these procedures.

Each device monitors the fieldbus and can send messages whenever the fieldbus is free. The device with the highest priority, i.e., the lowest CAN identifier, receives the access right. Devices with a lower priority interrupt the transmission and make a further access attempt once the fieldbus becomes free. However, this also means that there is no guaranteed transmission time for a message and that it is better to avoid excessive bus loading.

In CANopen the CAN identifier is encoded in a COB ID (Communication Object Identifier). This object type encodes also if the message is active or other CAN frame specific options. The CAN identifier for a CANopen message is made up of the function code and the node ID number.

The function code describes the message type:

- **Message with service data (SDO)**
For parameterization of object directory entries
 - Any length
 - Transmission "on request"
 - SDOs of a device are combined in the object directory
- **Message with process data (PDO)**
For transmitting immediate data
 - Maximum 8 bytes long
 - Cyclical or event-controlled transmission
 - Distinction between send (max. 512) and receive PDOs (max. 512)
 - In the CAN, PDOs occupy their own identifier
- **Messages for network management (NMT)**
For controlling the state machine of the CANopen device and for monitoring the network nodes

What is the difference between PDO and SDO?

PDO and SDO are 2 types of communication objects in CANopen that are used to exchange data between different devices within the network.

PDO (Process Data Object): PDOs are used for the cyclic exchange of process data between the participants of a CANopen network. They are used to transfer immediate data such as sensor measurements, actuator controls or status information between the devices. PDOs are sent and received at regular time intervals and are usually restricted to a limited amount of data.

SDO (Service Data Object): SDOs are used for the non-cyclical exchange of parameterization and diagnostic data. They enable the reading, writing and parameterization of data objects in the devices. Unlike PDOs, which are sent cyclically, SDOs are only used when a parameterization change or data exchange outside of the cyclical PDO exchange is required. SDOs offer greater flexibility in configuring and diagnosing devices, but also require more communication effort and latency than PDOs.

In summary, PDOs are used for the cyclic exchange of immediate data, while SDOs are used for the non-cyclic exchange of parameterization and diagnostic data. Both play an important role in a CANopen network and enable communication and interaction between devices.

Additional Information

CAN in Automation (CiA)

International Users and Manufacturers Group e.V.

Kontumazgarten 3

90429 Nuernberg, Germany

<http://www.can-cia.org/>

References: CAN Application Layer for industrial applications CAL-based communication profile for industrial systems

- CiA Draft Standard 301
- CiA Draft Standard 305 Layer Setting Services

6.2 CANopen Object Directory



Note

CANopen Parameter Communication

This section contains the information required for the data exchange via CANopen. Data is exchanged with the sensor via objects. These objects and their respective permissible functions are defined in the following object directory.

The sensor supports the identifier format 2.0A (11-bit identifier) according to the CAN specification. The extended 29-bit identifier is not supported.

The device-specific object directory OV contains all parameters and process data for the sensor. The object directory has two defined areas.

- 0x1000 ... 0x1FFF Communication segment: Predefined CANopen objects as specified in CiA301
 - 0x2000 ... 0x5FFF Manufacturer segment: manufacturer-specific CANopen objects
 - 0x6000 ... 0x9FFF Device Profile 410 Segment
-



Note

PDO mapping is not possible for most CANopen objects. For CANopen objects for which mapping is enabled, this is explicitly mentioned in the relevant sections of the CANopen objects.

The sensor is described in general terms in the 0x1000 area up to and including object 0x1FFF. The device ID, the name of the manufacturer, and the Communication Parameters are listed here. The 2nd area starting with object 0x2000 covers the specific functionality of the sensor. The area starting with object 0x6000 covers the inclination profile 410.

An entry in the object list is identified via a 16-bit index and an 8-bit subindex. The parameters and process data are described in detail in this manual as individual objects and are listed in tables. The following object list only lists the 16-bit index objects; the subindices are then described in the respective object descriptions. Access to device parameters and process data, such as input signals and output signals, device functions, and network variables, is provided via the assignment within the object list in standardized form over the CANopen network.

Supported Objects

Object	Description
0x1000	Device Type
0x1001	Error Register
0x1005	SYNC Identifier
0x1008	Manufacturer Device Name
0x1009	Manufacturer Hardware Version
0x100A	Manufacturer Software Version
0x1010	Store Parameters
0x1011	Restore Default Parameters
0x1017	Producer Heartbeat Time
0x1018	Device ID (Identify Object)
0x1200	Server SDO Parameter (Default SDO)
0x1800	TPDO1 Communication Parameter Inclination Device Profile 410
0x1804	TPDO5 Communication Parameter Acceleration
0x1805	TPDO6 Communication Parameter Rotation Rate
0x1806	TPDO7 Communication Parameter Rotational Acceleration Rate
0x1807	TPDO8 Communication Parameter Gravity Vector
0x1808	TPDO9 Communication Parameter Linear Acceleration
0x1809	TPDO10 Communication Parameter PF Angle
0x180A	TPDO11 Communication Parameter Euler Angle
0x180B	TPDO12 Communication Parameter Quaternion
0x180C	TPDO13 Communication Parameter Temperature
0x1A00	Device Profile 410 TPDO1 mapping parameter
0x1A04	Manufacturer TPDO5 Acceleration Mapping Parameter
0x1A05	Manufacturer TPDO6 Rotation Rate Mapping Parameter
0x1A06	Manufacturer TPDO7 Rotational Acceleration Rate Mapping Parameter
0x1A07	Manufacturer TPDO8 Gravity Vector Mapping Parameter
0x1A08	Manufacturer TPDO9 Linear Acceleration Mapping Parameter
0x1A09	Manufacturer TPDO10 PF Angle Mapping Parameter
0x1A0A	Manufacturer TPDO11 Euler Angle Mapping Parameter
0x1A0B	Manufacturer TPDO12 Quaternion Mapping Parameter
0x1A0C	Manufacturer TPDO13 Temperature Mapping Parameter
0x2000	Acceleration Data
0x2001	Acceleration Scaling/Offset
0x2002	Rotation Rate Data
0x2003	Rotation Rate Scaling/Offset
0x2004	Rotational Acceleration Rate Data
0x2005	Rotational Acceleration Rate Scaling/Offset
0x2006	Gravity Vector Data
0x2007	Gravity Vector Scaling/Offset
0x2008	Linear Acceleration Data
0x2009	Linear Acceleration Scaling/Offset

Object	Description
0x200A	PF angle data
0x200B	Euler Angle Data
0x200C	Angle Configuration
0x200D	Quaternation Data
0x200E	Quaternation Scaling/Offset
0x200F	Temperature Data
0x2010	Temperature Scaling/Offset
0x2100	Filter Setup Acceleration
0x2101	Filter Setup Rotation Rate
0x2103	Filter Setup Linear Acceleration
0x2104	Filter Setup Rotational Acceleration Rate
0x2105	Acceleration Application Flags (AF)
0x2106	Rotation Rate Application Flags (AF)
0x2107	Inclination Application Flags (AF)
0x2200	Application Tag
0x2201	PF Serial Number
0x6000	Resolution
0x6010	Slope Long16
0x6011	Slope Long16 Operating Parameter
0x6020	Slope Lateral16
0x6021	Slope Lateral16 Operating Parameter
0x6511	Device Temperature

Table 6.1

6.3 Object 0x1000 Device Type

Index	Subindex	Designation	Data type	Attribute	Default value
0x1000	0x00	Device Type	unsigned32 ¹	ro (= read only)	0x0102019a

Table 6.2

1. Data type without prefix, 32 bit

6.4 Object 0x1001 Error Register

Index	Subindex	Designation	Data type	Attribute	Default value
0x1001	0x00	Error Register	unsigned8	ro	0x0

Table 6.3

The 8-bit data of the error register describes errors as follows:

Bit							
7	6	5	4	3	2	1	0
0	Reserved	Reserved	Communication errors	Reserved	Reserved	Reserved	Generic error not specified in more detail ¹

Table 6.4

1. Flag is set for every error message

6.5 Object 0x1005 SYNC Identifier

Index	Subindex	Designation	Data type	Attribute	Default value
0x1005	0x00	COB-ID SYNC Message	unsigned32	rw (= read/write)	0x00000080

Table 6.5

The 32-bit data of the identifier in the SYNC message describes the synchronization as follows:

Bit				
31	30	29	28 ... 11	10 ... 0
Has no meaning	0 ¹	0	reserved	Identifier 0x80 = 128 _{dec}

Table 6.6

1. Always 0, since sensor is only for SYNC consumers, not SYNC producers

6.6 Object 0x1008 Manufacturer Device Name

Index	Subindex	Designation	Data type	Attribute	Default value
0x1008	0x00	Manufacturer Device Name	visible string ¹	ro	IMU F99

Table 6.7

1. ASCII string, variable length

6.7 Object 0x1009 Manufacturer Hardware Version

Index	Subindex	Designation	Data type	Attribute	Default value
0x1009	0x00	Manufacturer Hardware Version	visible string	ro	Value may change

Table 6.8

6.8 Object 0x100A Manufacturer Software Version

Index	Subindex	Designation	Data type	Attribute	Default value
0x100A	0x00	Manufacturer Software Version	visible string	ro	Value may change

Table 6.9

6.9 Object 0x1010 Store Parameters



Note

This object is only required for persistent storage of objects 0x1000 ... 0x1FFF. The objects 0x2000 ... 0x6FFF are saved automatically.

Index	Subindex	Designation	Data type	Attribute	Default value
0x1010	0x01	Save All Parameters	unsigned 32	rw	0x00000001

Table 6.10

In order to store parameters, write the specific code "0x65766173" in parameter 0x1010.

6.10 Object 0x1011 Restore Default Parameters

Index	Subindex	Designation	Data type	Attribute	Default value
0x1010	0x01	Restore all Default Parameters	unsigned 32	rw	0x00000001

Table 6.11

In order to restore factory parameter setting, write the specific code "0x64616f6c" in object 0x1011.

After switching the sensor off and on again or performing NMT reset node, factory settings will be restored. Reading always returns the default value. It effects all objects 0x1000 ... 0x6FFF.

6.11 Object 0x1017 Producer Heartbeat Time

Index	Subindex	Designation	Data type	Attribute	Default value
0x1017	0x00	Producer Heartbeat Time ¹	unsigned 16	rw	500

Table 6.12

1. Time span [ms] between two sent heartbeat messages

6.12 Object 0x1018 Device ID (Identity Object)

Index	Subindex	Designation	Data type	Attribute	Default value
0x1018	0x00	Highestsubindex supported	unsigned8	ro	0x4
	0x01	Vendor ID	unsigned32	ro	0xAD
	0x02	Product Code	unsigned32	ro	0x05000001
	0x03	Revision Number	unsigned32	ro	Value may change
	0x04	Serial Number	unsigned32	ro	Individual

Table 6.13

6.13 Object 0x1200 Server SDO Parameter (Default SDO)

Index	Subindex	Designation	Data type	Attribute	Default value
0x1200	0x00	Number of entries	unsigned8	ro	0x02
	0x01	COB ID Client to Server	unsigned32	ro	NODEID + 0x600
	0x02	COB ID Server to Client	unsigned32	ro	NODEID + 0x580

Table 6.14

6.14 Object 0x1800 TPDO1 Communication Parameter - Inclination CiA Profile 410

Index	Subindex	Designation	Data type	Attribute	Default value
0x1800	0x00	Highest subindex supported	unsigned8	ro	0x06
	0x01	COB ID	unsigned32	rw	NODEID + 0x180 Only invalid bit (TPDO present) will be stored. CAN ID is always set back to default value
	0x02	Transmission Type	unsigned8	rw	0x01 Explanation for other values: <ul style="list-style-type: none"> • 0x00: Every SYNC if changed • 0x01 ... 0xF0: Every n* SYNC message • 0xFE: Event-driven (manufacturer-specific event = every 10 ms)
	0x03	Inhibit Timer	unsigned16	rw	0x0000 Minimum interval for TPDO transmission (transmission type 0xFE). Multiple of 100 µs.
	0x05	Event Timer	unsigned16	rw	0x0000
	0x06	SYNC Start Value	unsigned8	rw	0x00

Table 6.15

COB ID: Bit			
31	30	29 ... 11	10 ... 0
Valid bit: 0 = valid 1 = invalid To activate/deactivate TPDO	RTR access: 0 = permitted 1 = not permitted Not supported	...	CAN identifier ¹

Table 6.16

1. Cannot be changed when PDO is currently present

6.15 Object 0x1804 TPDO5 Communication Parameter - Acceleration

Index	Subindex	Designation	Data type	Attribute	Default value
0x1804	0x00	Highest subindex supported	unsigned8	ro	0x06
	0x01	COB ID	unsigned32	rw	0x80000000 TPDO is deactivated by default
	0x02	Transmission Type	unsigned8	rw	0xFE Explanation for other values: <ul style="list-style-type: none"> • 0x00: Every SYNC if changed • 0x01 ... 0xF0: Every n* SYNC message • 0xFE: Event-driven (manufacturer-specific event = every 10 ms)
	0x03	Inhibit Time	unsigned16	rw	0x0000 Minimum interval for TPDO transmission (transmission type 0xFE). Multiple of 100 µs.
	0x05	Event Timer	unsigned16	rw	0x0000
	0x06	SYNC Start Value	unsigned8	rw	0x00

Table 6.17

6.16 Object 0x1805 TPDO6 Communication Parameter – Rotation Rate

Index	Subindex	Designation	Data type	Attribute	Default value
0x1805	0x00	Highest subindex supported	unsigned8	ro	0x06
	0x01	COB ID	unsigned32	rw	0x80000000 TPDO is deactivated by default
	0x02	Transmission Type	unsigned8	rw	0xFE Explanation for other values: <ul style="list-style-type: none"> • 0x00: Every SYNC if changed • 0x01 ... 0xF0: Every n* SYNC message • 0xFE: Event-driven (manufacturer-specific event = every 10 ms)
	0x03	Inhibit Time	unsigned16	rw	0x0000 Minimum interval for TPDO transmission (transmission type 0xFE). Multiple of 100 µs.
	0x05	Event Timer	unsigned16	rw	0x0000
	0x06	SYNC Start Value	unsigned8	rw	0x00

Table 6.18

6.17 Object 0x1806 TPDO7 Communication Parameter - Rotational Acceleration Rate

Index	Subindex	Designation	Data type	Attribute	Default value
0x1806	0x00	Highest subindex supported	unsigned8	ro	0x06
	0x01	COB ID	unsigned32	rw	0x80000000 TPDO is deactivated by default
	0x02	Transmission Type	unsigned8	rw	0xFE Explanation for other values: <ul style="list-style-type: none"> • 0x00: Every SYNC if changed • 0x01 ... 0xF0: Every n* SYNC message • 0xFE: Event-driven (manufacturer-specific event = every 10 ms)
	0x03	Inhibit Time	unsigned16	rw	0x0000 Minimum interval for TPDO transmission (transmission type 0xFE). Multiple of 100 µs.
	0x05	Event Timer	unsigned16	rw	0x0000
	0x06	SYNC Start Value	unsigned8	rw	0x00

Table 6.19

6.18 Object 0x1807 TPDO8 Communication Parameter - Gravity Vector

Index	Subindex	Designation	Data type	Attribute	Default value
0x1807	0x00	Highest subindex supported	unsigned8	ro	0x06
	0x01	COB ID	unsigned32	rw	0x80000000 TPDO is deactivated by default
	0x02	Transmission Type	unsigned8	rw	0xFE Explanation for other values: <ul style="list-style-type: none"> • 0x00: Every SYNC if changed • 0x01 ... 0xF0: Every n* SYNC message • 0xFE: Event-driven (manufacturer-specific event = every 10 ms)
	0x03	Inhibit Time	unsigned16	rw	0x0000 Minimum interval for TPDO transmission (transmission type 0xFE). Multiple of 100 µs.
	0x05	Event Timer	unsigned16	rw	0x0000
	0x06	SYNC Start Value	unsigned8	rw	0x00

Table 6.20

6.19 Object 0x1808 TPDO9 Communication Parameter - Linear Acceleration

Index	Subindex	Designation	Data type	Attribute	Default value
0x1808	0x00	Highest subindex supported	unsigned8	ro	0x06
	0x01	COB ID	unsigned32	rw	0x80000000 TPDO is deactivated by default
	0x02	Transmission Type	unsigned8	rw	0xFE Explanation for other values: <ul style="list-style-type: none"> • 0x00: Every SYNC if changed • 0x01 ... 0xF0: Every n* SYNC message • 0xFE: Event-driven (manufacturer-specific event = every 10 ms)
	0x03	Inhibit Time	unsigned16	rw	0x0000 Minimum interval for TPDO transmission (transmission type 0xFE). Multiple of 100 µs.
	0x05	Event Timer	unsigned16	rw	0x0000
	0x06	SYNC Start Value	unsigned8	rw	0x00

Table 6.21

6.20 Object 0x1809 TPDO10 Communication Parameter - PF Angle

Index	Subindex	Designation	Data type	Attribute	Default value
0x1809	0x00	Highest subindex supported	unsigned8	ro	0x06
	0x01	COB ID	unsigned32	rw	0x80000000 TPDO is deactivated by default
	0x02	Transmission Type	unsigned8	rw	0xFE Explanation for other values: <ul style="list-style-type: none"> • 0x00: Every SYNC if changed • 0x01 ... 0xF0: Every n* SYNC message • 0xFE: Event-driven (manufacturer-specific event = every 10 ms)
	0x03	Inhibit Time	unsigned16	rw	0x0000 Minimum interval for TPDO transmission (transmission type 0xFE). Multiple of 100 µs.
	0x05	Event Timer	unsigned16	rw	0x0000
	0x06	SYNC Start Value	unsigned8	rw	0x00

Table 6.22

6.21 Object 0x180A TPDO11 Communication Parameter - Euler Angle

Index	Subindex	Designation	Data type	Attribute	Default value
0x180A	0x00	Highest subindex supported	unsigned8	ro	0x06
	0x01	COB ID	unsigned32	rw	0x80000000 TPDO is deactivated by default
	0x02	Transmission Type	unsigned8	rw	0xFE Explanation for other values: <ul style="list-style-type: none"> • 0x00: Every SYNC if changed • 0x01 ... 0xF0: Every n* SYNC message • 0xFE: Event-driven (manufacturer-specific event = every 10 ms)
	0x03	Inhibit Time	unsigned16	rw	0x0000 Minimum interval for TPDO transmission (transmission type 0xFE). Multiple of 100 µs.
	0x05	Event Timer	unsigned16	rw	0x0000
	0x06	SYNC Start Value	unsigned8	rw	0x00

Table 6.23

6.22 Object 0x180B TPDO12 Communication Parameter - Quaternion

Index	Subindex	Designation	Data type	Attribute	Default value
0x180B	0x00	Highest subindex supported	unsigned8	ro	0x06
	0x01	COB ID	unsigned32	rw	0x80000000 TPDO is deactivated by default
	0x02	Transmission Type	unsigned8	rw	0xFE Explanation for other values: <ul style="list-style-type: none"> • 0x00: Every SYNC if changed • 0x01 ... 0xF0: Every n* SYNC message • 0xFE: Event-driven (manufacturer-specific event = every 10 ms)
	0x03	Inhibit Time	unsigned16	rw	0x0000 Minimum interval for TPDO transmission (transmission type 0xFE). Multiple of 100 µs.
	0x05	Event Timer	unsigned16	rw	0x0000
	0x06	SYNC Start Value	unsigned8	rw	0x00

Table 6.24

6.23 Object 0x180C TPDO13 Communication Parameter - Temperature

Index	Subindex	Designation	Data type	Attribute	Default value
0x180C	0x00	Highest subindex supported	unsigned8	ro	0x06
	0x01	COB ID	unsigned32	rw	0x80000000 TPDO is deactivated by default
	0x02	Transmission Type	unsigned8	rw	0xFE Explanation for other values: <ul style="list-style-type: none"> • 0x00: Every SYNC if changed • 0x01 ... 0xF0: Every n* SYNC message • 0xFE: Event-driven (manufacturer-specific event = every 10 ms)
	0x03	Inhibit Time	unsigned16	rw	0x0000 Minimum interval for TPDO transmission (transmission type 0xFE). Multiple of 100 µs.
	0x05	Event Timer	unsigned16	rw	0x0000
	0x06	SYNC Start Value	unsigned8	rw	0x00

Table 6.25

6.24 Object 0x1A00 TPDO1 Mapping - Inclination CiA Profile 410

Index	Subindex	Designation	Data type	Attribute	Default value	Description
0x1A00	0x01	Mapping Entry 1	unsigned32	ro	0x65110010	Device Temperature
	0x02	Mapping Entry 2	unsigned32	ro	0x60100010	Slope Long16
	0x03	Mapping Entry 3	unsigned32	ro	0x60200010	Slope Lateral16

Table 6.26

6.25 Object 0x1A04 TPDO5 Mapping - Acceleration

Index	Subindex	Designation	Data type	Attribute	Default value	Description
0x1A04	0x01	Mapping Entry 1	unsigned32	ro	0x20000110	Object Acceleration Data X
	0x02	Mapping Entry 2	unsigned32	ro	0x20000210	Object Acceleration Data Y
	0x03	Mapping Entry 3	unsigned32	ro	0x20000310	Acceleration Data Z
	0x04	Mapping Entry 4	unsigned32	ro	0x20000410	Object Acceleration Data Application Flag

Table 6.27

6.26 Object 0x1A05 TPDO6 Mapping - Rotation Rate

Index	Subindex	Designation	Data type	Attribute	Default value	Description
0x1A05	0x01	Mapping Entry 1	unsigned32	ro	0x20020110	Object Rotation Rate Data X
	0x02	Mapping Entry 2	unsigned32	ro	0x20020210	Object Rotation Rate Data Y
	0x03	Mapping Entry 3	unsigned32	ro	0x20020310	Object Rotation Rate Data Z
	0x04	Mapping Entry 4	unsigned32	ro	0x20020410	Object Rotation Rate Data Application Flag

Table 6.28

6.27 Object 0x1A06 TPDO7 Mapping - Rotational Acceleration Rate

Index	Subindex	Designation	Data type	Attribute	Default value	Description
0x1A06	0x01	Mapping Entry 1	unsigned32	ro	0x20040110	Object Rotational Acceleration Rate Data X
	0x02	Mapping Entry 2	unsigned32	ro	0x20040210	Object Rotational Acceleration Rate Data Y
	0x03	Mapping Entry 3	unsigned32	ro	0x20040310	Object Rotational Acceleration Rate Data Z

Table 6.29

6.28 Object 0x1A07 TPDO8 Mapping - Gravity Vector

Index	Subindex	Designation	Data type	Attribute	Default value	Description
0x1A07	0x01	Mapping Entry 1	unsigned32	ro	0x20060110	Object Gravity Data X
	0x02	Mapping Entry 2	unsigned32	ro	0x20060210	Object Gravity Data Y
	0x03	Mapping Entry 3	unsigned32	ro	0x20060310	Object Gravity Data Z

Table 6.30

6.29 Object 0x1A08 TPDO9 Mapping - Linear Acceleration

Index	Subindex	Designation	Data type	Attribute	Default value	Description
0x1A08	0x01	Mapping Entry 1	unsigned32	ro	0x20080110	Object Linear Acceleration Data X
	0x02	Mapping Entry 2	unsigned32	ro	0x20080210	Object Linear Acceleration Data Y
	0x03	Mapping Entry 3	unsigned32	ro	0x20080310	Object Linear Acceleration Data Z

Table 6.31

6.30 Object 0x1A09 TPD10 Mapping - PF Angle

Index	Subindex	Designation	Data type	Attribute	Default value	Description
0x1A09	0x01	Mapping Entry 1	unsigned32	ro	0x200A0110	Object PF Angle Data X
	0x02	Mapping Entry 2	unsigned32	ro	0x200A0210	Object PF Angle Data Y
	0x03	Mapping Entry 3	unsigned32	ro	0x200A0310	Object PF Angle Data Z
	0x04	Mapping Entry 3	unsigned32	ro	0x200A0410	Object PF Angle Data Application Flag

Table 6.32

6.31 Object 0x1A0A TPD11 Mapping - Euler Angle

Index	Subindex	Designation	Data type	Attribute	Default value	Description
0x1A0A	0x01	Mapping Entry 1	unsigned32	ro	0x200B0110	Object Euler Angle Data X
	0x02	Mapping Entry 2	unsigned32	ro	0x200B0210	Object Euler Angle Data Y
	0x03	Mapping Entry 3	unsigned32	ro	0x200B0310	Object Euler Angle Data Z
	0x04	Mapping Entry 4	unsigned32	ro	0x200B0410	Object Euler Angle Data Application Flag

Table 6.33

6.32 Object 0x1A0B TPD12 Mapping - Quaternion

Index	Subindex	Designation	Data type	Attribute	Default value	Description
0x1A0B	0x01	Mapping Entry 1	unsigned32	ro	0x200D0110	Object Quaternion Data X
	0x02	Mapping Entry 2	unsigned32	ro	0x200D0210	Object Quaternion Data Y
	0x03	Mapping Entry 3	unsigned32	ro	0x200D0310	Object Quaternion Data Z
	0x04	Mapping Entry 3	unsigned32	ro	0x200D0410	Object Quaternion Data W

Table 6.34

6.33 Object 0x1A0C TPD13 Mapping - Temperature

Index	Subindex	Designation	Data type	Attribute	Default value	Description
0x1A0C	0x01	Mapping Entry 1	unsigned32	ro	0x200F0110	Object Temperature Data MEMS
	0x02	Mapping Entry 2	unsigned32	ro	0x200F0210	Object Temperature Data Mainboard

Table 6.35

6.34 Object 0x2000 Acceleration Data

Index	Subindex	Designation	Data type	Attribute	Default value	Description
0x2000	0x01	Acceleration X	integer16	ro	–	Acceleration in X direction
	0x02	Acceleration Y	integer16	ro	–	Acceleration in Y direction
	0x03	Acceleration Z	integer16	ro	–	Acceleration in Z direction
	0x04	Application Flag Acceleration	unsigned16	ro	–	Status of adjustable application flags of each axis for acceleration

Table 6.36

6.35 Object 0x2001 Acceleration Scaling/Offset

Index	Subindex	Designation	Data type	Attribute	Default value	Description
0x2001	0x01	Factor	unsigned16	rw	1000	Factor of acceleration
	0x02	Offset	unsigned16	rw	0	Offset of acceleration

Table 6.37

6.36 Object 0x2002 Rotation Rate Data

Index	Subindex	Designation	Data type	Attribute	Default value	Description
0x2002	0x01	Rotation Rate X	integer16	ro	–	Rotation rate around the X axis
	0x02	Rotation Rate Y	integer16	ro	–	Rotation rate around the Y axis
	0x03	Rotation Rate Z	integer16	ro	–	Rotation rate around the Z axis
	0x04	Application Flag Rotation Rate	signed16	ro	–	Status of adjustable application flags of each axis for rotation rate

Table 6.38

6.37 Object 0x2003 Rotation Rate Scaling/Offset

Index	Subindex	Designation	Data type	Attribute	Default value	Description
0x2003	0x01	Factor	unsigned16	rw	100	Factor of Rotation Rate
	0x02	Offset	unsigned16	rw	0	Offset of Rotation Rate

Table 6.39

6.38 Object 0x2004 Rotational Acceleration Data

Index	Subindex	Designation	Data type	Attribute	Default value	Description
0x2004	0x01	Rotational Acceleration X	signed16	ro	–	Rotational acceleration around the X axis
	0x02	Rotational Acceleration Y	signed16	ro	–	Rotational acceleration around the Y axis
	0x03	Rotational Acceleration Z	signed16	ro	–	Rotational acceleration around the Z axis

Table 6.40

6.39 Object 0x2005 Rotational Acceleration Scaling/Offset

Index	Subindex	Designation	Data type	Attribute	Default value	Description
0x2005	0x01	Factor	unsigned16	rw	1	Factor of rotational acceleration
	0x02	Offset	unsigned16	rw	0	Offset of rotational acceleration

Table 6.41

6.40 Object 0x2006 Gravity Vector Data

Index	Subindex	Designation	Data type	Attribute	Default value	Description
0x2006	0x01	Gravity X	integer16	ro	–	Proportion of the gravity vector in x direction without external acceleration
	0x02	Gravity Y	integer16	ro	–	Proportion of the gravity vector in y direction without external acceleration
	0x03	Gravity Z	integer16	ro	–	Proportion of the gravity vector in z direction without external acceleration

Table 6.42

6.41 Object 0x2007 Gravity Vector Scaling/Offset

Index	Subindex	Designation	Data type	Attribute	Default value	Description
0x2007	0x01	Factor	unsigned16	rw	1000	Factor of gravity vector
	0x02	Offset	unsigned16	rw	0	Offset of gravity vector

Table 6.43

6.42 Object 0x2008 Linear Acceleration Data

Index	Subindex	Designation	Data type	Attribute	Default value	Description
0x2008	0x01	Linear Acceleration X	integer16	ro	–	Acceleration in X direction without gravity vector
	0x02	Linear Acceleration Y	integer16	ro	–	Acceleration in Y direction without gravity vector
	0x03	Linear Acceleration Z	integer16	ro	–	Acceleration in Z direction without gravity vector

Table 6.44

6.43 Object 0x2009 Linear Acceleration Scaling/Offset

Index	Subindex	Designation	Data type	Attribute	Default value	Description
0x2009	0x01	Factor	unsigned16	rw	1000	Factor of linear acceleration
	0x02	Offset	unsigned16	rw	0	Offset of linear acceleration

Table 6.45

6.44 Object 0x200A PF Angle Data

Index	Subindex	Designation	Data type	Attribute	Default value	Description
0x200A	0x01	PF Angle X	unsigned16	ro	–	Angle X-axis
	0x02	PF Angle Y	unsigned16	ro	–	Angle Y-axis
	0x03	PF Angle Z	unsigned16	ro	–	Angle Z-axis
	0x04	App Flag Angle Grav Flag	unsigned16	ro	–	Status of adjustable application flags of each axis for inclination measurement. Status of autonomous gravity flags of each axis for inclination measurement.

Table 6.46

6.45 Object 0x200B Euler Angle Data

Index	Subindex	Designation	Data type	Attribute	Default value	Description
0x200B	0x01	Euler Angle Roll	integer16	ro	–	Euler Angle: psi
	0x02	Euler Angle Pitch	integer16	ro	–	Euler Angle: theta
	0x03	Euler Angle Yaw	integer16	ro	–	Euler Angle: phi
	0x04	App Flag Angle Grav Flag	unsigned16	ro	–	Status of adjustable application flags of each axis for inclination measurement. Status of autonomous gravity flags of each axis for inclination measurement.

Table 6.47

6.46 Object 0x200C Angle Configuration

Index	Subindex	Designation	Data type	Attribute	Default value	Description
0x200C	0x01	Factor	unsigned16	rw	100	Factor of angle
	0x02	Offset	unsigned16	rw	0	Offset of angle
	0x03	Angle Definition	unsigned8	rw	2	<p>Euler Angles definition:</p> <ul style="list-style-type: none"> 0 = z,y',x'' [DIN 9300;DIN 70000] Intrinsic coordinate system that rotates with the sensor body. Value range $\pm 180^\circ$ 1 = ZXZ Extrinsic coordinate system of the horizontal plane. Value range $\pm 180^\circ$ <p>P +F Angles definition:</p> <ul style="list-style-type: none"> 2 = INX [Pepperl + Fuchs] Extrinsic coordinate system of the horizontal plane. Value range 0 ... 360° 3 = INY [Pepperl + Fuchs] Extrinsic coordinate system of the horizontal plane. Value range 0 ... 360° 4 = INZ [Pepperl + Fuchs] Intrinsic coordinate system that rotates with the sensor body. Value range 0 ... 360°
	0x04	Compensation range	unsigned8	rw	4	<p>The choice of the parameter affects the quality of the angle output depending on the motion profile of the application. The larger the value selected, the better-sustained linear accelerations can be compensated. The lower the value selected, the better short shocks can be compensated. A quantitative statement must be tested in each individual case. Range: 0 ... 7</p>

Table 6.48



Note

Adjusting the subindex requires a power cycle for the change to have a functional effect.

6.47 Object 0x200D Quaternion Data

Index	Subindex	Designation	Data type	Attribute	Default value	Description
0x200D	0x01	Quaternion X	integer16	ro	–	Quaternion Data X
	0x02	Quaternion Y	integer16	ro	–	Quaternion Data Y
	0x03	Quaternion Z	integer16	ro	–	Quaternion Data Z Note: Output value is always "0"
	0x04	Quaternion W	integer16	ro	–	Quaternion Data W

Table 6.49

6.48 Object 0x200E Quaternion Scaling/Offset

Index	Subindex	Designation	Data type	Attribute	Default value	Description
0x200E	0x01	Factor	unsigned16	rw	1000	Factor of quaternion
	0x02	Offset	unsigned16	rw	0	Offset of quaternion

Table 6.50

6.49 Object 0x200F Temperature Data

Index	Subindex	Designation	Data type	Attribute	Default value	Description
0x200F	0x01	Temperature MEMS	integer16	ro	–	Temperature of the sensor element
	0x02	Temperature Mainboard	integer16	ro	–	Temperature of the mainboard

Table 6.51

6.50 Object 0x2010 Temperature Scaling/Offset

Index	Subindex	Designation	Data type	Attribute	Default value	Description
0x2010	0x01	Factor	unsigned16	rw	10	Factor of temperature
	0x02	Offset	unsigned16	rw	0	Offset of temperature

Table 6.52

6.51 Object 0x2100 Filter Setup Acceleration

Index	Subindex	Designation	Data type	Attribute	Default value	Description
0x2100	0x01	Type	unsigned8	rw	0	Filter type
	0x02	Order	unsigned8	rw	1	Filter order 0 = off
	0x03	Frequency	unsigned16	rw	20000	Cut-off frequency of Filter in mHz

Table 6.53

Note

Adjusting the subindex requires a power cycle for the change to have a functional effect.



6.52 Object 0x2101 Filter Setup Rotation Rate

Index	Subindex	Designation	Data type	Attribute	Default value	Description
0x2101	0x01	Type	unsigned8	rw	1	Filter type
	0x02	Order	unsigned8	rw	0	Filter order 0 = off
	0x03	Frequency	unsigned16	rw	50000	Cut-off frequency of Filter in mHz

Table 6.54



Note

Adjusting the subindex requires a power cycle for the change to have a functional effect.

6.53 Object 0x2102 Filter Setup Gravity Vector and Angle

Index	Subindex	Designation	Data type	Attribute	Default value	Description
0x2102	0x01	Type	unsigned8	rw	0	Filter type
	0x02	Order	unsigned8	rw	0	Filter order
	0x03	Frequency	unsigned16	rw	50000	Cut-off frequency of Filter in mHz

Table 6.55



Note

Adjusting the subindex requires a power cycle for the change to have a functional effect.

6.54 Object 0x2103 Filter Setup Linear Acceleration

Index	Subindex	Designation	Data type	Attribute	Default value	Description
0x2103	0x01	Type	unsigned8	rw	0	Filter type
	0x02	Order	unsigned8	rw	0	Filter order
	0x03	Frequency	unsigned16	rw	50000	Cut-off frequency of Filter in mHz

Table 6.56



Note

Adjusting the subindex requires a power cycle for the change to have a functional effect.

6.55 Object 0x2104 Filter Setup Rotational Acceleration Rate

Index	Subindex	Designation	Data type	Attribute	Default value	Description
0x2104	0x01	Type	unsigned8	rw	0	Filter type
	0x02	Order	unsigned8	rw	1	Filter order
	0x03	Frequency	unsigned16	rw	10000	Cut-off frequency of Filter in mHz

Table 6.57



Note

Adjusting the subindex requires a power cycle for the change to have a functional effect.

6.56 Object 0x2105 Acceleration Application Flags (AF)

Index	Subindex	Designation	Data type	Attribute	Default value	Description
0x2105	0x01	Mode for X-axis	unsigned8	rw	0x00	For acceleration X-axis: 0 = deactivated; The status of the application flag is statically "inactive". Set limits are ignored. 1 = single point; The status of the application flag only switches depending on Limit1. Limit2 is ignored. 2 = windows; The range of values between Limit1 and Limit2 determines the status of the application flag. The value for Limit1 and Limit2 can be selected independently of each other.
0x2105	0x02	SP1 for X-axis/Set Point 1 for X-axis	unsigned16	rw	0x7FFF	For acceleration X-axis: The value of this switching point parameter determines the Limit1, exceeding or falling below it leads to a change in the switching status for the application flag. The value of Limit1 can be chosen independently of Limit2.
0x2105	0x03	SP2 for X-axis/Set Point 2 for X-axis	unsigned16	rw	0x7FFF	For acceleration X-axis: The value of this switching point parameter determines the Limit2, exceeding or falling below it leads to a change in the switching status for the application flag. The value of Limit2 can be chosen independently of Limit1.

Index	Subindex	Designation	Data type	Attribute	Default value	Description
0x2105	0x04	Logic for X-axis	unsigned8	rw	0x00	<p>For acceleration X-axis: This parameter determines which value range of the Limits should be displayed as the "active" value range.</p> <ul style="list-style-type: none"> 0 = low active: <p>In single point mode - if the value falls below Limit1 (independent of sign), AF is set to "low". If Limit1 is exceeded (independent of sign), AF is set to "high". In window mode - If the value is between Limit1 and Limit2, AF is set to "low". If the value is outside of Limit1 and Limit2, AF is set to "high".</p> <ul style="list-style-type: none"> 1 = high active: <p>In single point mode - if the value falls below Limit1 (independent of sign), AF is set to "high". If Limit1 is exceeded (independent of sign), AF is set to "low". In window mode - If the value is between Limit1 and Limit2, AF is set to "high". If the value is outside of Limit1 and Limit2, AF is set to "low".</p>
0x2105	0x05	Mode for Y-axis	unsigned8	rw	0x00	<p>For acceleration Y-axis: 0 = deactivated; The status of the application flag is statically "inactive". Set Limits are ignored. 1 = single point; The status of the application flag only switches depending on Limit1. Limit2 is ignored. 2 = windows; The range of values between Limit1 and Limit2 determines the status of the application flag. The value for Limit1 and Limit2 can be selected independently of each other.</p>
0x2105	0x06	SP1 for Y-axis/Set Point 1 for Y-axis	unsigned16	rw	0x7FFF	<p>For acceleration Y-axis: The value of this switching point parameter determines the Limit1, exceeding or falling below it leads to a change in the switching status for the application flag. The value of Limit1 can be chosen independently of Limit2.</p>

Index	Subindex	Designation	Data type	Attribute	Default value	Description
0x2105	0x07	SP2 for Y-axis/Set Point 2 for Y-axis	unsigned16	rw	0x7FFF	For acceleration Y-axis: The value of this switching parameter determines the Limit2, exceeding or falling below it leads to a change in the switching status for the application flag. The value of Limit2 can be chosen independently of Limit1.
0x2105	0x08	Logic for Y-axis	unsigned8	rw	0x00	For acceleration Y-axis: This parameter determines which value range of the Limits should be displayed as the "active" value range. <ul style="list-style-type: none"> 0 = low active: In single point mode - if the value falls below Limit1 (independent of sign), AF is set to "low". If Limit1 is exceeded (independent of sign), AF is set to "high". In window mode - If the value is between Limit1 and Limit2, AF is set to "low". If the value is outside of Limit1 and Limit2, AF is set to "high". <ul style="list-style-type: none"> 1 = high active: In single point mode - if the value falls below Limit1 (independent of sign), AF is set to "high". If Limit1 is exceeded (independent of sign), AF is set to "low". In window mode - If the value is between Limit1 and Limit2, AF is set to "high". If the value is outside of Limit1 and Limit2, AF is set to "low".
0x2105	0x09	Mode for Z-axis	unsigned8	rw	0x00	For acceleration Z-axis: 0 = deactivated; The status of the application flag is statically "inactive". Set Limits are ignored. 1 = single point; The status of the application flag only switches depending on Limit1. Limit2 is ignored. 2 = windows; The range of values between Limit1 and Limit2 determines the status of the application flag. The value for Limit1 and Limit2 can be selected independently of each other.

Index	Subindex	Designation	Data type	Attribute	Default value	Description
0x2105	0x0A	SP1 for Z-axis/Set Point 1 for Z-axis	unsigned16	rw	0x7FFF	For acceleration Z-axis: The value of this switching point parameter determines the Limit1, exceeding or falling below it leads to a change in the switching status for the application flag. The value of Limit1 can be chosen independently of Limit2.
0x2105	0x0B	SP2 for Z-axis/Set Point 2 for Z-axis	unsigned16	rw	0x7FFF	For acceleration Z-axis: The value of this switching point parameter determines the Limit2, exceeding or falling below it leads to a change in the switching status for the application flag. The value of Limit2 can be chosen independently of Limit1.
0x2105	0x0C	Logic for Z-axis	unsigned8	rw	0x00	For acceleration Z-axis: This parameter determines which value range of the Limits should be displayed as the "active" value range. <ul style="list-style-type: none"> 0 = low active: <p>In single point mode - if the value falls below Limit1 (independent of sign), AF is set to "low". If Limit1 is exceeded (independent of sign), AF is set to "high".</p> <p>In window mode - If the value is between Limit1 and Limit2, AF is set to "low". If the value is outside of Limit1 and Limit2, AF is set to "high".</p> 1 = high active: <p>In single point mode - if the value falls below Limit1 (independent of sign), AF is set to "high". If Limit1 is exceeded (independent of sign), AF is set to "low".</p> <p>In window mode - If the value is between Limit1 and Limit2, AF is set to "high". If the value is outside of Limit1 and Limit2, AF is set to "low".</p>

Table 6.58

6.57 Object 0x2106 Rotation Rate Application Flags (AF)

Index	Subindex	Designation	Data type	Attribute	Default value	Description
0x2106	0x01	Mode for X-axis	unsigned8	rw	0x00	For rotation rate X-axis: 0 = deactivated; The status of the application flag is statically "inactive". Set limits are ignored. 1 = single point; The status of the application flag only switches depending on Limit1. Limit2 is ignored. 2 = windows; The range of values between Limit1 and Limit2 determines the status of the application flag. The value for Limit1 and Limit2 can be selected independently of each other.
0x2106	0x02	SP1 for X-axis/Set Point 1 for X-axis	unsigned16	rw	0x7FFF	For rotation rate X-axis: The value of this switching point object determines the Limit1, exceeding or falling below it leads to a change in the switching status for the application flag. The value of Limit1 can be chosen independently of Limit2.
0x2106	0x03	SP2 for X-axis/Set Point 2 for X-axis	unsigned8	rw	0x7FFF	For rotation rate X-axis: The value of this switching point object determines the Limit2, exceeding or falling below it leads to a change in the switching status for the application flag. The value of Limit2 can be chosen independently of Limit1.

Index	Subindex	Designation	Data type	Attribute	Default value	Description
0x2106	0x04	Logic for X-axis	unsigned8	rw	0x00	<p>For rotation rate X-axis: This parameter determines which value range of the Limits should be displayed as the "active" value range.</p> <ul style="list-style-type: none"> 0 = low active: <p>In single point mode - if the value falls below Limit1 (independent of sign), AF is set to "low". If Limit1 is exceeded (independent of sign), AF is set to "high". In window mode - If the value is between Limit1 and Limit2, AF is set to "low". If the value is outside of Limit1 and Limit2, AF is set to "high".</p> <ul style="list-style-type: none"> 1 = high active: <p>In single point mode - if the value falls below Limit1 (independent of sign), AF is set to "high". If Limit1 is exceeded (independent of sign), AF is set to "low". In window mode - If the value is between Limit1 and Limit2, AF is set to "high". If the value is outside of Limit1 and Limit2, AF is set to "low".</p>
0x2106	0x05	Mode for Y-axis	unsigned8	rw	0x00	<p>For rotation rate Y-axis: 0 = deactivated; The status of the application flag is statically "inactive". Set limits are ignored. 1 = single point; The status of the application flag only switches depending on Limit1. Limit2 is ignored. 2 = windows; The range of values between Limit1 and Limit2 determines the status of the application flag. The value for Limit1 and Limit2 can be selected independently of each other.</p>
0x2106	0x06	SP1 for Y-axis/Set Point 1 for Y-axis	unsigned16	rw	0x7FFF	<p>For rotation rate Y-axis: The value of this switching point parameter determines the Limit1, exceeding or falling below it leads to a change in the switching status for the application flag. The value of Limit1 can be chosen independently of Limit2.</p>

Index	Subindex	Designation	Data type	Attribute	Default value	Description
0x2106	0x07	SP2 for Y-axis/Set Point 2 for Y-axis	unsigned16	rw	0x7FFF	For rotation rate Y-axis: The value of this switching point parameter determines the Limit2, exceeding or falling below it leads to a change in the switching status for the application flag. The value of Limit2 can be chosen independently of Limit1.
0x2106	0x08	Logic for Y-axis	unsigned8	rw	0x00	For rotation rate Y-axis: This parameter determines which value range of the Limits should be displayed as the "active" value range. <ul style="list-style-type: none"> 0 = low active: <p>In single point mode - if the value falls below Limit1 (independent of sign), AF is set to "low". If Limit1 is exceeded (independent of sign), AF is set to "high".</p> <p>In window mode - If the value is between Limit1 and Limit2, AF is set to "low". If the value is outside of Limit1 and Limit2, AF is set to "high".</p> <ul style="list-style-type: none"> 1 = high active: <p>In single point mode - if the value falls below Limit1 (independent of sign), AF is set to "high". If Limit1 is exceeded (independent of sign), AF is set to "low".</p> <p>In window mode - If the value is between Limit1 and Limit2, AF is set to "high". If the value is outside of Limit1 and Limit2, AF is set to "low".</p>
0x2106	0x09	Mode for Z-axis	unsigned8	rw	0x00	For rotation rate Z-axis: 0 = deactivated; The status of the application flag is statically "inactive". Set limits are ignored. 1 = single point; The status of the application flag only switches depending on Limit1. Limit2 is ignored. 2 = windows; The range of values between Limit1 and Limit2 determines the status of the application flag. The value for Limit1 and Limit2 can be selected independently of each other.

Index	Subindex	Designation	Data type	Attribute	Default value	Description
0x2106	0x0A	SP1 for Z-axis/Set Point 1 for Z-axis	unsigned16	rw	0x7FFF	For rotation rate Z-axis: The value of this switching point parameter determines the Limit1, exceeding or falling below it leads to a change in the switching status for the application flag. The value of Limit1 can be chosen independently of Limit2.
0x2106	0x0B	SP2 for Z-axis/Set Point 2 for Z-axis	unsigned16	rw	0x7FFF	For rotation rate Z-axis: The value of this switching point parameter determines the Limit2, exceeding or falling below it leads to a change in the switching status for the application flag. The value of Limit2 can be chosen independently of Limit1.
0x2106	0x0C	Logic for Z-axis	unsigned8	rw	0x00	For rotation rate Z-axis: This parameter determines which value range of the Limits should be displayed as the "active" value range. <ul style="list-style-type: none"> 0 = low active: <p>In single point mode - if the value falls below Limit1 (independent of sign), AF is set to "low". If Limit1 is exceeded (independent of sign), AF is set to "high".</p> <p>In window mode - If the value is between Limit1 and Limit2, AF is set to "low". If the value is outside of Limit1 and Limit2, AF is set to "high".</p> 1 = high active: <p>In single point mode - if the value falls below Limit1 (independent of sign), AF is set to "high". If Limit1 is exceeded (independent of sign), AF is set to "low".</p> <p>In window mode - If the value is between Limit1 and Limit2, AF is set to "high". If the value is outside of Limit1 and Limit2, AF is set to "low".</p>

Table 6.59

6.58 Object 0x2107 Inclination Application Flags (AF)

Index	Subindex	Designation	Data type	Attribute	Default value	Description
0x2107	0x01	Mode for X-axis	unsigned8	rw	0x00	Just use it in combination with INX/INY/INZ inclination setting. Don't use it with ZYZ or zy'x" inclination setting. 0 = deactivated; The status of the application flag is statically "inactive". Set limits are ignored. 1 = single point; The status of the application flag only switches depending on Limit1. Limit2 is ignored. 2 = windows; The range of values between Limit1 and Limit2 determines the status of the application flag. The value for Limit1 and Limit2 can be selected independently of each other.
0x2107	0x02	SP1 for X-axis/Set Point 1 for X-axis	unsigned16	rw	0x0000	Just use it in combination with INX/INY/INZ inclination setting. Don't use it with ZYZ or zy'x" inclination setting. For inclination X-axis: The value of this switching point parameter determines the limit 1, exceeding or falling below it leads to a change in the switching status for the application flag. The value of Limit1 can be chosen independently of Limit2.
0x2107	0x03	SP2 for X-axis/Set Point 2 for X-axis	unsigned16	rw	0x0000	Just use it in combination with INX/INY/INZ inclination setting. Don't use it with ZYZ or zy'x" inclination setting. For inclination X-axis: The value of this switching point parameter determines the Limit2, exceeding or falling below it leads to a change in the switching status for the application flag. The value of Limit2 can be chosen independently of Limit1.

Index	Subindex	Designation	Data type	Attribute	Default value	Description
0x2107	0x04	Logic for X-axis	unsigned8	rw	0x00	<p>Just use it in combination with INX/INY/INZ inclination setting. Don't use it with ZYZ or zy'x" inclination setting.</p> <p>For inclination X-axis: This parameter determines which value range of the Limits should be displayed as the "active" value range.</p> <ul style="list-style-type: none"> 0 = low active: <p>In single point mode - if the value falls below Limit1 (independent of sign), AF is set to "low". If Limit1 is exceeded (independent of sign), AF is set to "high".</p> <p>In window mode - If the value is between Limit1 and Limit2, AF is set to "low". If the value is outside of Limit1 and Limit2, AF is set to "high".</p> <ul style="list-style-type: none"> 1 = high active: <p>In single point mode - if the value falls below Limit1 (independent of sign), AF is set to "high". If Limit1 is exceeded (independent of sign), AF is set to "low".</p> <p>In window mode - If the value is between Limit1 and Limit2, AF is set to "high". If the value is outside of Limit1 and Limit2, AF is set to "low".</p>
0x2107	0x05	Mode for Y-axis	unsigned8	rw	0x00	<p>Just use it in combination with INX/INY/INZ inclination setting. Don't use it with ZYZ or zy'x" inclination setting.</p> <p>For inclination Y-axis: 0 = deactivated; The status of the application flag is statically "inactive". Set limits are ignored.</p> <p>1 = single point; The status of the application flag only switches depending on Limit1. Limit2 is ignored.</p> <p>2 = windows; The range of values between Limit1 and Limit2 determines the status of the application flag. The value for Limit1 and Limit2 can be selected independently of each other.</p>

Index	Subindex	Designation	Data type	Attribute	Default value	Description
0x2107	0x06	SP1 for Y-axis/Set Point 1 for Y-axis	unsigned16	rw	0x0000	Just use it in combination with INX/INY/INZ inclination setting. Don't use it with ZYZ or zy'x" inclination setting. For inclination y-axis: The value of this switching point parameter determines the limit 1, exceeding or falling below it leads to a change in the switching status for the application flag. The value of Limit1 can be chosen independently of Limit2.
0x2107	0x07	SP2 for Y-axis/Set Point 2 for Y-axis	unsigned16	rw	0x0000	Just use it in combination with INX/INY/INZ inclination setting. Don't use it with ZYZ or zy'x" inclination setting. For inclination y-axis: The value of this switching point parameter determines the Limit2, exceeding or falling below it leads to a change in the switching status for the application flag. The value of Limit2 can be chosen independently of Limit1.
0x2107	0x08	Logic for Y-axis	unsigned8	rw	0x00	Just use it in combination with INX/INY/INZ inclination setting. Don't use it with ZYZ or zy'x" inclination setting. For inclination y-axis: This parameter determines which value range of the Limits should be displayed as the "active" value range. <ul style="list-style-type: none"> 0 = low active: <p>In single point mode - if the value falls below Limit1 (independent of sign), AF is set to "low". If Limit1 is exceeded (independent of sign), AF is set to "high". In window mode - If the value is between Limit1 and Limit2, AF is set to "low". If the value is outside of Limit1 and Limit2, AF is set to "high".</p> <ul style="list-style-type: none"> 1 = high active: <p>In single point mode - if the value falls below Limit1 (independent of sign), AF is set to "high". If Limit1 is exceeded (independent of sign), AF is set to "low". In window mode - If the value is between Limit1 and Limit2, AF is set to "high". If the value is outside of Limit1 and Limit2, AF is set to "low".</p>

Index	Subindex	Designation	Data type	Attribute	Default value	Description
0x2107	0x09	Mode for Z-axis	unsigned8	rw	0x00	Just use it in combination with INX/INY/INZ inclination setting. Don't use it with ZYZ or zy'x' inclination setting. For inclination Z-axis: 0 = deactivated; The status of the application flag is statically "inactive". Set limits are ignored. 1 = single point; The status of the application flag only switches depending on Limit1. Limit2 is ignored. 2 = windows; The range of values between Limit1 and Limit2 determines the status of the application flag. The value for Limit1 and Limit2 can be selected independently of each other.
0x2107	0x0A	SP1 for Z-axis/Set Point 1 for Z-axis	unsigned16	rw	0x0000	Just use it in combination with INX/INY/INZ inclination setting. Don't use it with ZYZ or zy'x' inclination setting. For inclination Z-axis: The value of this switching point parameter determines the limit 1, exceeding or falling below it leads to a change in the switching status for the application flag. The value of Limit1 can be chosen independently of Limit2.
0x2107	0x0B	SP2 for Z-axis/Set Point 2 for Z-axis	unsigned16	rw	0x0000	Just use it in combination with INX/INY/INZ inclination setting. Don't use it with ZYZ or zy'x' inclination setting. For inclination Z-axis: The value of this switching point parameter determines the Limit2, exceeding or falling below it leads to a change in the switching status for the application flag. The value of Limit2 can be chosen independently of Limit1.

Index	Subindex	Designation	Data type	Attribute	Default value	Description
0x2107	0x0C	Logic for Z-Axis	unsigned8	rw	0x00	<p>Just use it in combination with INX/INY/INZ inclination setting. Don't use it with ZYZ or zy"x" inclination setting.</p> <p>For inclination z-axis: This parameter determines which value range of the limits should be displayed as the "active" value range.</p> <ul style="list-style-type: none"> 0 = low active: <p>In single point mode - if the value falls below Limit1 (independent of sign), AF is set to "low". If Limit1 is exceeded (independent of sign), AF is set to "high".</p> <p>In window mode - If the value is between Limit1 and Limit2, AF is set to "low". If the value is outside of Limit1 and Limit2, AF is set to "high".</p> <ul style="list-style-type: none"> 1 = high active: <p>In single point mode - if the value falls below Limit1 (independent of sign), AF is set to "high". If Limit1 is exceeded (independent of sign), AF is set to "low".</p> <p>In window mode - If the value is between Limit1 and Limit2, AF is set to "high". If the value is outside of Limit1 and Limit2, AF is set to "low".</p>

Table 6.60

6.59 Object 0x2200 Application Tag

Index	Subindex	Designation	Data type	Attribute	Default value	Meaning
0x2200	0x00	Application Tag	visible string	rw	Your automation, our passion	P+F marketing text

Table 6.61

6.60 Object 0x2201 PF Serial Number

Index	Subindex	Designation	Data type	Attribute	Default value	Meaning
0x2201	0x00	PF Serial Number	visible string	ro	unique	–

Table 6.62

6.61 Object 0x6000 Resolution

Index	Subindex	Designation	Data type	Attribute	Default value	Meaning
0x6000	0x00	Resolution	unsigned16	ro	10	Multiple of 0.001°

Table 6.63

6.62 Object 0x6010 Slope Long16

Index	Subindex	Designation	Data type	Attribute	Default value	Description
0x6010	0x00	Slope Long16	integer16	ro	–	Angle X-axis value

Table 6.64

6.63 Object 0x6011 Slope Long16 Operating Parameter

Index	Subindex	Designation	Data type	Attribute	Default value	Meaning
0x6011	0x00	Slope Long16 Operating Parameter	unsigned8	rw	0	Bit0: Direction of rotation reversal <ul style="list-style-type: none"> • 0: Clockwise • 1: Counter clockwise

Table 6.65

6.64 Object 0x6020 Slope Lateral16

Index	Subindex	Designation	Data type	Attribute	Default value	Meaning
0x6020	0x00	Slope Lateral16	integer16	ro	–	Angle Y-axis value

Table 6.66

6.65 Object 0x6021 Slope Lateral16 Operating Parameter

Index	Subindex	Designation	Data type	Attribute	Default value	Meaning
0x6021	0x00	Slope Lateral16 Operating Parameter	unsigned8	rw	0	Bit0: Direction of rotation reversal <ul style="list-style-type: none"> • 0: Clockwise • 1: Counter clockwise

Table 6.67

6.66 Object 0x6511 Device Temperature

Index	Subindex	Designation	Data type	Attribute	Default value	Meaning
0x6511	0x00	Device Temperature	integer16	ro	–	Temperature value

Table 6.68

Your automation, our passion.

Explosion Protection

- Intrinsic Safety Barriers
- Signal Conditioners
- FieldConnex® Fieldbus
- Remote I/O Systems
- Electrical Ex Equipment
- Purge and Pressurization
- Industrial HMI
- Mobile Computing and Communications
- HART Interface Solutions
- Surge Protection
- Wireless Solutions
- Level Measurement

Industrial Sensors

- Proximity Sensors
- Photoelectric Sensors
- Industrial Vision
- Ultrasonic Sensors
- Rotary Encoders
- Positioning Systems
- Inclination and Acceleration Sensors
- Fieldbus Modules
- AS-Interface
- Identification Systems
- Displays and Signal Processing
- Connectivity

Pepperl+Fuchs Quality

Download our latest policy here:

www.pepperl-fuchs.com/quality

