

**PMI15V-F112-...-IO-... Series**

**Parameterizing  
Inductive Position Measurement Systems  
with IO-Link Interface**

**Manual**



Your automation, our passion.

 **PEPPERL+FUCHS**

---

With regard to the supply of products, the current issue of the following document is applicable:  
The General Terms of Delivery for Products and Services of the Electrical Industry, published  
by the Central Association of the Electrical Industry (Zentralverband Elektrotechnik und Elek-  
troindustrie (ZVEI) e.V.) in its most recent version as well as the supplementary clause:  
"Expanded reservation of proprietorship"

**Worldwide**

Pepperl+Fuchs Group  
Lilienthalstr. 200  
68307 Mannheim  
Germany  
Phone: +49 621 776 - 0  
E-mail: [info@de.pepperl-fuchs.com](mailto:info@de.pepperl-fuchs.com)

**North American Headquarters**

Pepperl+Fuchs Inc.  
1600 Enterprise Parkway  
Twinsburg, Ohio 44087  
USA  
Phone: +1 330 425-3555  
E-mail: [sales@us.pepperl-fuchs.com](mailto:sales@us.pepperl-fuchs.com)

**Asia Headquarters**

Pepperl+Fuchs Pte. Ltd.  
P+F Building  
18 Ayer Rajah Crescent  
Singapore 139942  
Phone: +65 6779-9091  
E-mail: [sales@sg.pepperl-fuchs.com](mailto:sales@sg.pepperl-fuchs.com)  
<https://www.pepperl-fuchs.com>

<b>1</b>	<b>Introduction</b> .....	<b>5</b>
1.1	Content of this Document.....	5
1.2	Target Group, Personnel .....	5
1.3	Symbols Used .....	5
1.4	Intended Use .....	6
1.5	General Safety Instructions .....	6
<b>2</b>	<b>Product Description</b> .....	<b>8</b>
2.1	Use and Application .....	8
2.2	Accessories.....	9
2.2.1	Damping Element.....	9
2.2.2	Parameterization Aids.....	11
2.2.3	M12 Connection Cable .....	11
<b>3</b>	<b>IO-Link Parameterization</b> .....	<b>12</b>
3.1	Safety Information .....	12
3.2	Definition of the Measuring Range/Position .....	12
3.3	Preparation.....	13
3.4	Mounting.....	13
3.5	Connection .....	14
<b>4</b>	<b>Commissioning</b> .....	<b>15</b>
4.1	Commissioning with IO-Link on a Control Panel (Online Parameterization).....	15
4.2	Commissioning with IO-Link via FDT Frame Application (Offline Parameterization).....	15
<b>5</b>	<b>Process Data Structure</b> .....	<b>17</b>
5.1	MDC—Measurement Value .....	17
5.2	MDC—Scale.....	17
5.3	DSC—Signal Quality Indicator .....	17
5.4	SSC.1—Switching Signal .....	17
5.5	SSC.2—Switching Signal .....	18
<b>6</b>	<b>Switching Signal Characteristics</b> .....	<b>19</b>
6.1	Window Mode with SP1 and SP2 .....	19
6.2	Centered Window Mode with SP1 and Offset .....	20
6.3	Hysteresis with SP1 and SP2 .....	20

<b>7</b>	<b>Maintenance and Repair .....</b>	<b>22</b>
7.1	Maintenance .....	22
7.2	Resetting the Output Functions to the Factory Default.....	22
<b>8</b>	<b>Troubleshooting .....</b>	<b>23</b>
8.1	What to Do in Case of a Fault.....	23

# 1 Introduction

## 1.1 Content of this Document

This document contains information required to use the product in the relevant phases of the product life cycle. This may include information on the following:

- Product identification
- Delivery, transport, and storage
- Mounting and installation
- Commissioning and operation
- Maintenance and repair
- Troubleshooting
- Dismounting
- Disposal



---

**Note**

For full information on the product, refer to the further documentation on the Internet at [www.pepperl-fuchs.com](http://www.pepperl-fuchs.com).

---



---

**Note**

For specific device information such as the year of construction, scan the QR code on the device. As an alternative, enter the serial number in the serial number search at [www.pepperl-fuchs.com](http://www.pepperl-fuchs.com).

---

The documentation comprises the following parts:

- This document
- Datasheet

In addition, the documentation may comprise the following parts, if applicable:

- EU-type examination certificate
- EU declaration of conformity
- Attestation of conformity
- Certificates
- Control drawings
- Instruction manual
- Functional safety manual
- Other documents

## 1.2 Target Group, Personnel

Responsibility for planning, assembly, commissioning, operation, maintenance, and dismantling lies with the plant operator.

Only appropriately trained and qualified personnel may carry out mounting, installation, commissioning, operation, maintenance, and dismantling of the product. The personnel must have read and understood the instruction manual and the further documentation.

Prior to using the product make yourself familiar with it. Read the document carefully.

## 1.3 Symbols Used

This document contains symbols for the identification of warning messages and of informative messages.

### Warning Messages

You will find warning messages, whenever dangers may arise from your actions. It is mandatory that you observe these warning messages for your personal safety and in order to avoid property damage.

Depending on the risk level, the warning messages are displayed in descending order as follows:



---

#### **Danger!**

This symbol indicates an imminent danger.

Non-observance will result in personal injury or death.

---



---

#### **Warning!**

This symbol indicates a possible fault or danger.

Non-observance may cause personal injury or serious property damage.

---



---

#### **Caution!**

This symbol indicates a possible fault.

Non-observance could interrupt the device and any connected systems and plants, or result in their complete failure.

---

### Informative Symbols



---

#### **Note**

This symbol brings important information to your attention.

---



---

#### **Action**

This symbol indicates a paragraph with instructions. You are prompted to perform an action or a sequence of actions.

## 1.4 Intended Use

The PMI15V-F112-...-IO-... inductive position measurement system with IO-Link is optimized for highly accurate, continuous position detection. Based on the precise evaluation of several coil systems, the device combines proven inductive sensor technology with innovative micro-controller technology.

The compact design of the F112 enables noncontact and wear-free position detection to a measuring length of 15 mm, even in confined installation locations.

Typical applications include positioning tasks in clamping systems. Read through this manual carefully. Familiarize yourself with the device before installing, mounting, or operating it.

Always operate the device as described in these instructions to ensure that the device and connected systems function correctly. The protection of operating personnel and the plant is guaranteed only if the device is operated in accordance with its intended use.

## 1.5 General safety instructions

Responsibility for planning, assembly, commissioning, operation, maintenance, and dismounting lies with the plant operator.

Installation and commissioning of all devices may be performed only by trained and qualified personnel.

It is dangerous for the user to make changes and/or repairs. Additionally, doing so voids the warranty and excludes the manufacturer from any liability. In the event of any serious errors, stop using the device. Secure the device against unintended operation. To have the device repaired, return it to your local Pepperl+Fuchs representative or your sales center.



---

### Note

#### Disposal

Electronic waste is dangerous. When disposing of the equipment, observe the current statutory requirements in the relevant country of use and local regulations.

---

## 2 Product Description

### 2.1 Use and Application

The PMI15V-F112-...-IO-... inductive position measurement system with IO-Link is optimized for highly accurate, continuous position detection. Based on the precise evaluation of several coil systems, the device combines proven inductive sensor technology with innovative micro-controller technology.

The compact and rugged design of the F112 enables noncontact and wear-free position detection to a measuring length of 15 mm. This includes installation locations where space is limited.

With its integrated temperature compensation feature, the inductive position measurement system is ideal for use in harsh environments and for critical positioning tasks.

Due to the inductive sensing principle, ferrites or magnets are not necessary as a counterpart. The detection of the position is carried out through the detection of a damping element mounted on a monitoring object. For precise detection, the damping element must keep to specified measurements (see chapter 2.2.1). A typical area of application for the PMI15V-F112-...-IO-... is monitoring spindles in clamping systems.

The advantages of the PMI15V-F112-...-IO-... inductive position measurement system are:

- High resolution and accuracy
- End-to-end communication between the control panel and field level via IO-Link
- Noncontact operation
- Higher immunity due to inductive sensing principle

The PMI15V-F112-...-IO-... inductive position measurement system is designed for connection to IO-Link and represents the measured position value and virtual switch points in the process data.

The PMI15V-F112-...-IO-... product group also supports SIO mode. SIO mode (standard IO mode) can be used to perform conventional signal transmission (i.e., on/off signal) between the device and the higher-level control panel.

#### What Is IO-Link?

IO-Link enables seamless communication and digital data transfer from the control panel level down to the sensor level. The intelligent sensors can be used to their full potential with IO-Link, paving the way for Industry 4.0 in automation technology. The internationally standardized interface provides impressive efficiency and sustainable cost reduction from plant design and installation right through operation and servicing.

Standardized device description files ("IODDs") and parameterization via software tools ensure convenient configuration and integration of IO-Link sensors. Intelligent, transparent parameter management increases application flexibility and minimizes downtimes. Parameters can be customized quickly and easily, even for complex production and batch changes. Transparency right through to the sensor gives users access to a comprehensive range of parameterization options and device diagnostics functions, allowing them to perform predictive maintenance.

The technology offers particular benefits during service activities (troubleshooting, maintenance, and device replacement), during commissioning (cloning, identification, configuration, and localization), and during operation (job changeover, continuous parameter monitoring, and online diagnostics).

#### Device Description File (IODD)

The device parameters are different for each device. A standardized description of these parameters can be found in the IO Device Description file (IODD). IODDs can be integrated into a control environment to allow IO-Link devices to be used for IO-Link operation. Both parameterization and process data exchange can be performed with a PLC. The IODD can also be imported into a range of engineering tools from various system providers for parameterization and diagnostics, provided these tools support IODD.

### Offline Parameterization

With offline parameterization, IO-Link devices are already configured before installation. To do this, use the Pepperl+Fuchs IO-Link USB master.

We recommend using the "PACTware" software as the FDT frame application and user interface.

The software components required in each case are collated in the latest version of the "IO-Link Offline Parameterization Tool" software package. The software package and the documentation on its installation and use can be found online at [www.pepperl-fuchs.com](http://www.pepperl-fuchs.com).

If the "IO-Link Offline Parameterization Tool" software package is used, there is active internet access, and the device is connected via the Pepperl+Fuchs IO-Link USB master, the IODD can be directly integrated into the IO-Link Offline Parameterization Tool via the "IODD DTM Configurator."

The device description file (IODD) required for integration into an IO-Link system and for the parameterization and diagnostics is available online. Visit [www.pepperl-fuchs.com](http://www.pepperl-fuchs.com) and navigate to the relevant product page for the PMI15V-F112-...-IO-...

### Online Parameterization

When commissioning machines and plants, master and IO-Link devices must be integrated into the appropriate control environment. Depending on the components used, different software is required.

The devices can be configured and parameterized using an IO-Link configuration tool. During operation, you can check the parameters for the IO-Link devices, read, and monitor status data and diagnostic data. IO-Link data is integrated into an application program using function blocks.

## 2.2 Accessories

Various accessories are available.

### 2.2.1 Damping Element

We recommend using the BT-F90-W or BT-F90-G as the damping element.

**BT-F90-W**

Material: S235 steel (St37)

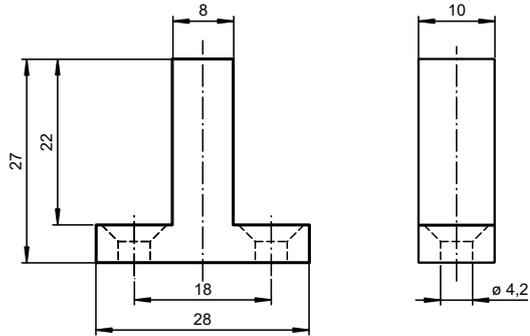

**BT-F90-G**

Material: S235 steel (St37)

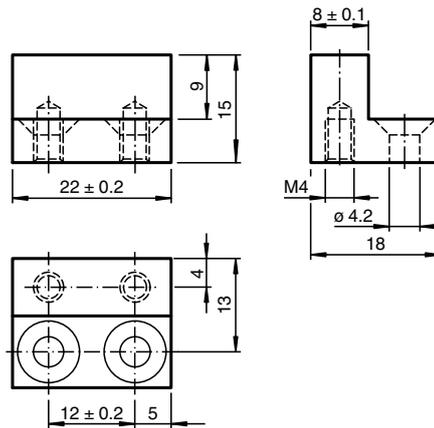

**Using a Different Damping Element**

In principle, it is possible to use your own damping element. The damping element must have the following properties to be able to make use of the sensor's specified accuracy:

Material: Construction steel such as S235JR+AR (previously St37-2)

Dimensions (L x W x H):  $\geq 18 \text{ mm} \times 8 \text{ mm} \times \geq 4 \text{ mm}$

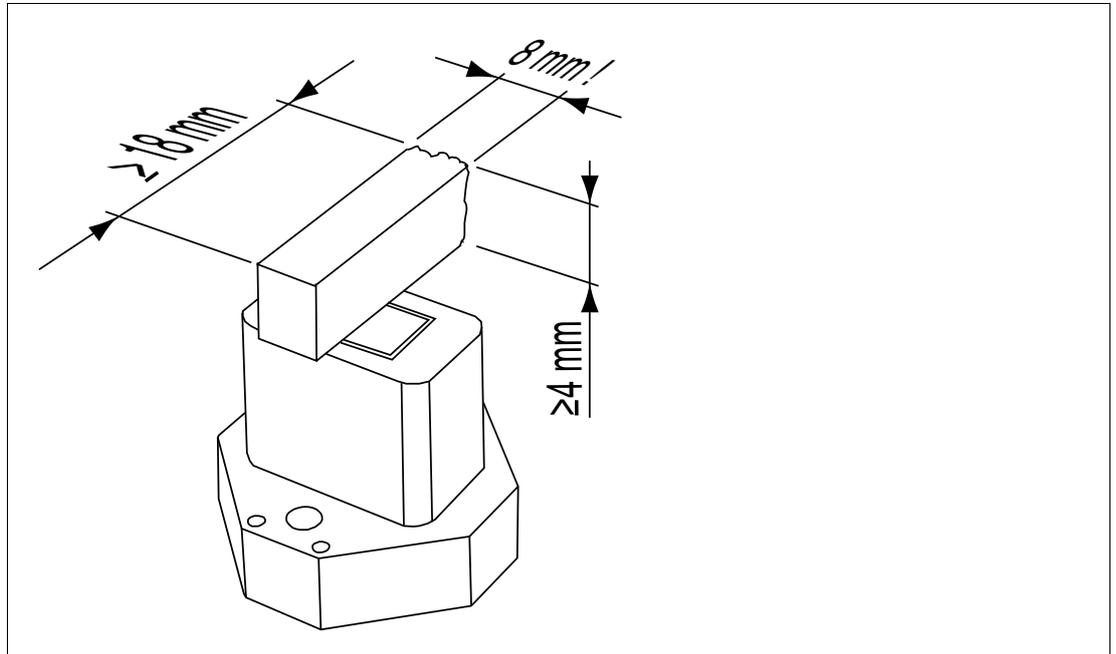

Figure 2.1



**Note**

The exact width of the damping element of  $8 \text{ mm} \pm 0.1 \text{ mm}$  must be observed. The edges should be broken with a maximum chamfer of 0.1 mm. If the width of the damping element deviates from this value, the position values will differ.

**2.2.2**

**Parameterization Aids**

The following parameterization aids are available:

Designation	Description
Pepperl-Fuchs-PMI15V-F112-...-IO-...IODDx.x	IO device description (IODD)—device description for operating the sensor, integration in the system environment Refer to the product page for the relevant PMI15V-F112-...-IO-... at <a href="http://www.pepperl-fuchs.com">www.pepperl-fuchs.com</a>
IO-Link Offline Parameterization Tool	FDT frame application for operating IODDs and DTMs. This tool contains PACTware, IODD Interpreter DTM, and IO-Link USB Master DTM. Refer to the product page for the relevant PMI15V-F112-...-IO-... series sensor at <a href="http://www.pepperl-fuchs.com">www.pepperl-fuchs.com</a>
IO-Link-Master02-USB	IO-Link USB adapter box to communicate with the IO-Link device via a PC, M12 connection for sensor

### 2.2.3 M12 Connection Cable

The following cordsets are suitable for the electrical connection of the PMI15V-F112-...-IO-... devices with an M12 connector plug. They are available in different lengths and in an angled version:

Illustration	Material	M12 x 1 cordset, 4-pin	M12 x 1 cordset, 5-pin
	PVC	V1-G-*-PVC-V1-G	V15-G-*-PVC-V15-G
	PUR	V1-G-*-PUR-V1-G	V15-G-*-PUR-V15-G

#### Note

If the cordset will be used in environments with significant potential for electromagnetic interference, please use shielded single-ended female cordsets from our extensive range of accessories.

### 3 IO-Link Parameterization

Only the parameters of the PMI15V-F112-...-IO-... product group that require explanation are listed below.



---

**Note**

A comprehensive overview of all parameters for the respective position measurement system can be found online at [www.pepperl-fuchs.com](http://www.pepperl-fuchs.com). Navigate to the relevant product page for the PMI15V-F112-...-IO-... and click on the corresponding "IO-Link Parameter Datasheet" document.

For a clear reference to the "IO-Link Parameter Datasheet" document and for easily finding all parameter information, parameter names and some terms are listed below.

The following explanations of SSC.1 parameters also apply to SSC.2 parameters.

---

The abbreviations below are used in the following:

**ro** read only

**wo** write only

**rw** read and write

#### 3.1 Safety Information



---

**Caution!**

Risk of short circuit

Carrying out work while the system is energized may result in damage to the device.

- Always disconnect the supply voltage before carrying out work on the device.
  - Only connect the device to the supply voltage once all work has been completed.
-

### 3.2 Definition of the Measuring Range/Position

A reference mark (1) indicates the start of the measuring range on the positioning system.

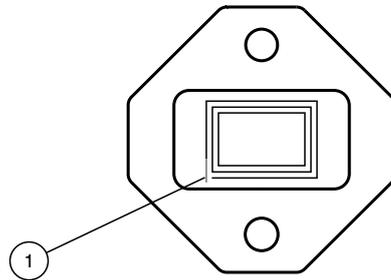

The position of the damping element defined by the positioning system relates to half of the width (center) of the damping element. The measuring range begins and ends with the half coverage provided by the damping element when moving lengthwise.

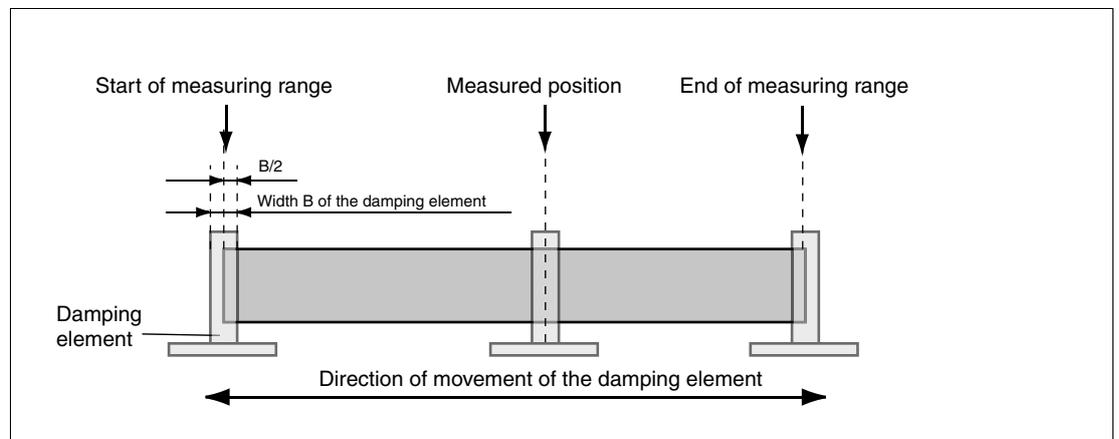

Figure 3.1

### 3.3 Preparation



#### Unpacking the Device

1. Check the packaging and contents for damage.  
↳ In the event of damage, inform the shipping company and notify the supplier.
2. Check the package contents against your order and the shipping documents to ensure that all items are present and correct.  
↳ Should you have any questions, direct them to Pepperl+Fuchs.
3. Retain the original packaging in case the device is to be stored or shipped again at a later date.

### 3.4 Mounting

- A flush mount is possible in metallic and nonmetallic environments.
- The distance between the measuring field (framed area at the front of the sensor) and the mounting base or fastening screws on the damping element must be at least 3 mm.  
Watch out for any protruding metal parts such as screw heads when mounting the device.
- The damping element must be attached to the sensor at a right angle to guarantee the relevant measurement accuracy.
- The distance between the damping element and the sensor can be a maximum of 2.5 mm and must be at least 1 mm.

#### Distance of the Damping Element

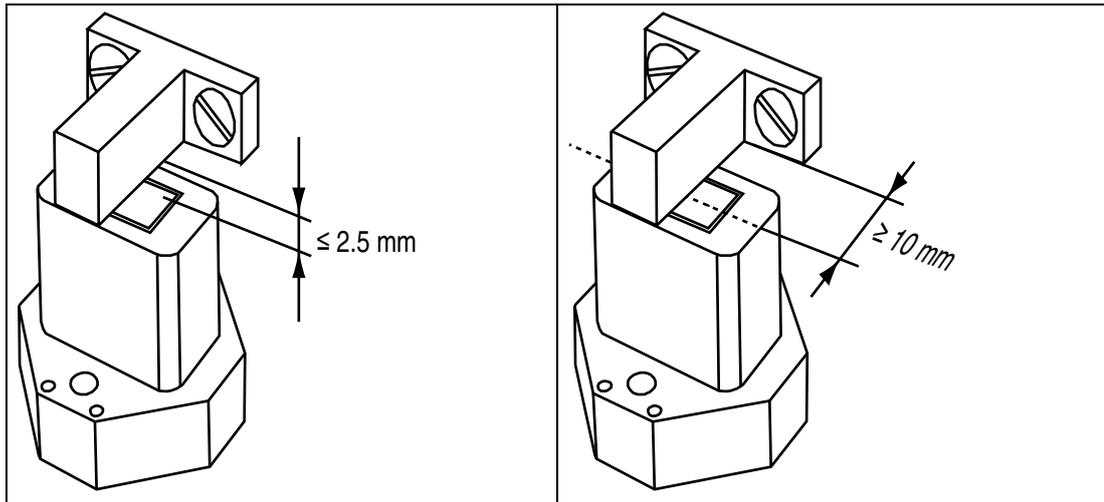

### 3.5 Connection



#### Connecting the Supply Voltage

To supply voltage to the sensor, proceed as follows:

1. Now connect the supply voltage to the cable strands or plugs provided.  
↳ The sensor is ready for operation.



#### Communication via IO-Link

To prepare the sensor for communication via IO-Link, proceed as follows:

1. Connect the sensor to an IO-Link master. Use a three-wire or four-wire sensor cable for the connection.  
↳ The sensor is now prepared for IO-Link communication.

Sensor	Electrical Connection	Pinout
PMI15V-F112-EP-IO-V1		

Table 3.1



#### Note

The list of electrical connections above represents just some of the products in our range of position measurement systems equipped with IO-Link. The list is not exhaustive. Please refer to the datasheet for the connection diagram for your sensor. This datasheet is available to download from the Pepperl+Fuchs website at [www.pepperl-fuchs.com](http://www.pepperl-fuchs.com).

## 4 Commissioning

### 4.1 Commissioning with IO-Link on a Control Panel (Online Parameterization)



#### Note

The device description file (IODD) required for integration into an IO-Link system and for the parameterization and diagnostics is available online. Visit [www.pepperl-fuchs.com](http://www.pepperl-fuchs.com) and navigate to the relevant product page for the PMI15V-F112-...-IO-...



To activate the position measurement system via IO-Link using a control panel, proceed as follows:

1. Check the connection between the position measurement system and the IO-Link master.
2. Set the status to "IO-Link" on the corresponding port on the IO-Link master to which the position measurement system is connected.

↳ The position measurement system can now either be parameterized using the IO-Link configuration tool or diagnosed using the modulated application. The device sends the binary switching information and the position value as process data.

### 4.2 Commissioning with IO-Link via FDT Frame Application (Offline Parameterization)

#### IO-Link Offline Parameterization Tool

An IODD (IO-Link Device Description) file is available to download for parameterization of the position measurement system via IO-Link and diagnostics. Go to the product page at [www.pepperl-fuchs.com](http://www.pepperl-fuchs.com) for the relevant PMI15V-F112-...-IO-... position measurement system or via the IODDfinder <https://ioddfinder.io-link.com/>.

With offline parameterization, IO-Link devices are already configured before installation. To do this, use the Pepperl+Fuchs IO-Link USB master.

The software components required in each case are collated in the latest version of the "IO-Link Offline Parameterization Tool" software package. The software package and the documentation on its installation and use can be found online at [www.pepperl-fuchs.com](http://www.pepperl-fuchs.com).

If the "IO-Link Offline Parameterization Tool" software package is used, there is active internet access, and the device is connected via the Pepperl+Fuchs IO-Link USB master, the IODD can be directly integrated into the IO-Link Offline Parameterization Tool via the "IODD DTM Configurator."



#### Note

A three-wire or four-wire M12 cordset is required for connecting the position measurement system to the Pepperl+Fuchs IO-Link master. You can find suitable cordsets by visiting [www.pepperl-fuchs.com](http://www.pepperl-fuchs.com) and clicking on the product page for the relevant position measurement system.



To activate the position measurement system via IO-Link using the corresponding IODD, proceed as follows:

1. Make sure that the "IO-Link Offline Parameterization Tool" software package is installed on the computer.
2. Connect the position measurement system to an IO-Link master via a suitable M12 cordset.
3. Connect the IO-Link master to a USB port on your PC via a USB cable.
4. Start PACTware.

↳ PACTware automatically communicates with the position measurement system if you are using PACTware from the "IO-Link Offline Parameterization Tool" and automatically found the IODD online.

## 5 Process Data Structure

The process data of the position measurement system consists of 32 bits (4 bytes). The following table provides an overview of the order and structure of the process data.

Name	Data Type	Length	Bit Offset	Value
MDC—Measurement Value	Integer	16 bits	16	<MV1_min> ... <MV1_max> -32760: Out of range (-) 32760: Out of range (+) 32764: No measurement data
MDC—Scale	Integer	8 bits	8	-5: resolution 10 µm
DSC—Signal Quality Indicator	Integer	2 bits	2	0: Insufficient 1: Acceptable 2: Good 3: Excellent
SSC.2—Switching Signal 2	Boolean	1 bit	1	0 = Low 1 = High
SSC.1—Switching Signal 1	Boolean	1 bit	0	0 = Low 1 = High

Table 5.1

### 5.1 MDC—Measurement Value

#### Measurement Data Channel—Measurement Value

The "MDC—Measurement Value" process data content returns the current position of the recorded damping element (center of the damping element) in the measuring range of the position measurement system.

### 5.2 MDC—Scale

#### Measurement Data Channel—Scale

The position value contained in the process data can be converted to the base unit specified in the "MDC Descriptor—Unit Code" parameter. The exponent defined by "Scale" to base 10 is used for this purpose.

For example, a scale value of -5 together with the base unit of "m" specifies a resolution of  $10^{-5} \text{ m} = 10 \text{ µm}$ .

### 5.3 DSC—Signal Quality Indicator

#### Diagnosis Signal Channel—Signal Quality Indicator

The process data content "DSC—Signal Quality Indicator" indicates the quality of the sensor signal. This allows optimal adjustment of the distance between the sensor and the damping element. Misalignment is detected prematurely.

## 5.4 SSC.1—Switching Signal

### Switching Signal Channel 1—Switching Signal

The "SSC.1—Switching Signal" process data content refers to a signal bit used to detect a position that is critical for the application. It is part of the cyclic signal transmission. Depending on the status of the position measurement system or the state of the application, the signal bit can have the value "0" or "1."

The following parameters influence the switching characteristics of the SSC1 process data:

- SSC.1 Param: SP1
- SSC.1 Param: SP2
- SSC.1 Config: Logic
- SSC.1 Config: Mode
- SSC.1 Config: Hyst
- SSC.1 Ext: SP Offset
- SSC.1 Ext: Pulse Extension
- SSC.1 Ext: Substitute Behavior

## 5.5 SSC.2—Switching Signal

### Switching Signal Channel 2—Switching Signal

The "SSC.2—Switching Signal" process data content refers to a signal bit used to detect a position that is critical for the application. It is part of the cyclic signal transmission. Depending on the status of the position measurement system or the state of the application, the signal bit can have the value "0" or "1."

The following parameters affect the switching characteristics of the SSC2 process data:

- SSC.2 Param: SP1
- SSC.2 Param: SP2
- SSC.2 Config: Logic
- SSC.2 Config: Mode
- SSC.2 Config: Hyst
- SSC.2 Ext: SP Offset
- SSC.2 Ext: Pulse Extension
- SSC.2 Ext: Substitute Behavior

## 6 Switching Signal Characteristics

The following sections use examples to describe the switching signal characteristics of the inductive position measurement system for the "SSC.1—Switching Signal 1" process data. The switching signal characteristics for the "SSC.2—Switching Signal 2" process data work in the same way. You can set and use both switching signal channels independently of each other.

### 6.1 Window Mode with SP1 and SP2

The parameters of SP1 (setpoint 1) and SP2 (setpoint 2) can be set differently to accommodate different application types. The figure below illustrates this.

#### Switch point SP1 > SP2

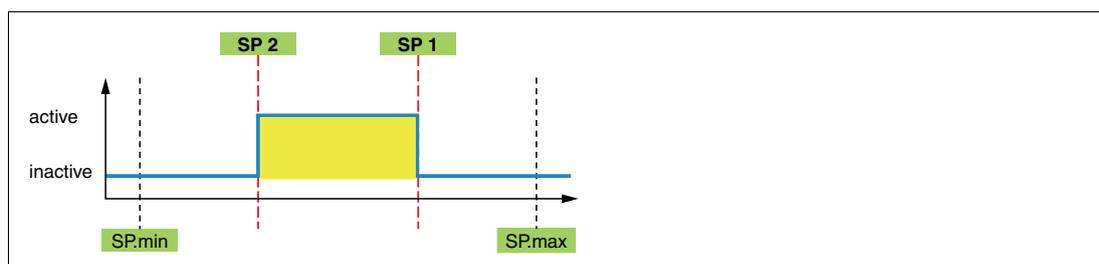

Figure 6.1

#### Switch point SP2 > SP1

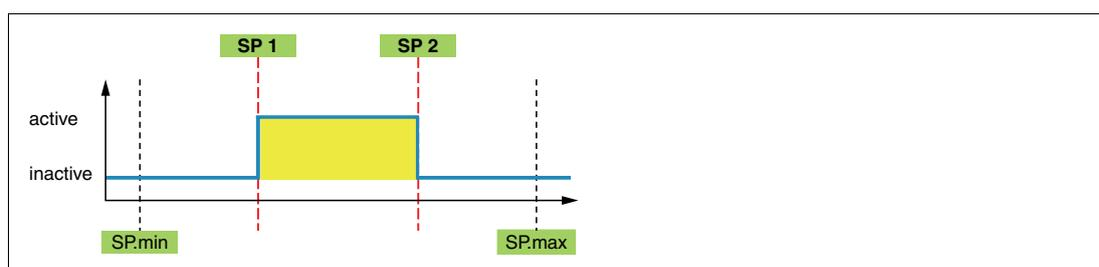

Figure 6.2

#### Switch point SP1 = SP2

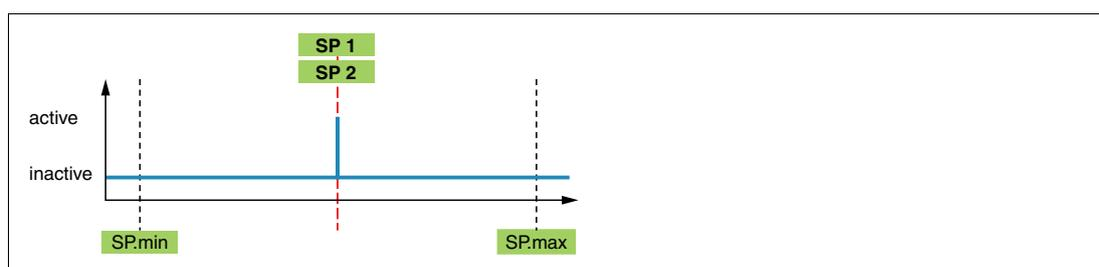

Figure 6.3

The SP1 (setpoint 1) and SP2 (setpoint 2) switch points can be used as the upper or lower switching threshold for the associated switching signal channel, depending on the assigned value. The switch point with the higher value is referred to as the upper switching limit; the switch point with the lower value is referred to as the lower switching limit. The colored value range between the lower and upper switching limit is known as the window range.

SP1 (setpoint 1) and SP2 (setpoint 2) can be configured with the same assigned value and loaded into the device. However, since the upper and lower switching limits have the same value, the switching signal channel does not indicate any change if this value is exceeded or is not reached.

Using the "SSC.1 Config: Logic" (0x3D Sub 1) parameter, you can set the required switching characteristics as "high active" or "low active."

The general rule for switch points SP1 and SP2 is:

Switch points SP1 and SP2 can be set independently of one another.

- SP1 can be greater than SP2
- SP1 can be smaller than SP2
- SP1 can be equal to SP2

## 6.2 Centered Window Mode with SP1 and Offset

You can set the window width defined by the centered window SP1 and the offset, so that the window starts before the measuring range start or stops only after the end of the measuring range.

It should be noted that the window is automatically shortened on one side such that it starts no earlier than the start of the measuring range and stops no later than the end of the measuring range. Positions outside the measuring range never fall within the window.

The figure below illustrates this.

### Centered Window at SP.min.

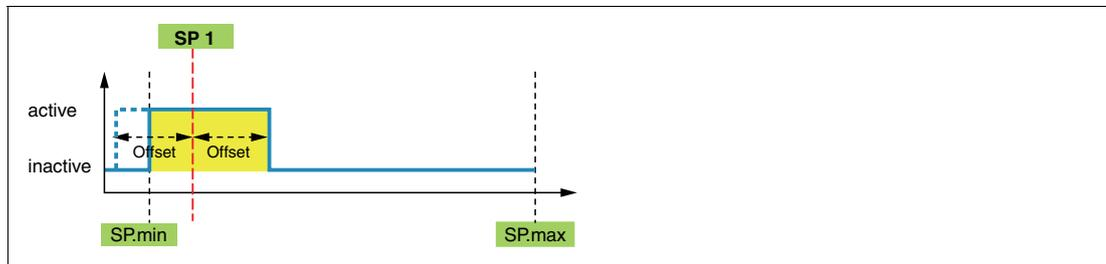

Figure 6.4

The actual window area is shown in yellow; the set, ineffective area smaller than the zero point is shown in dashed lines.

### 6.3 Hysteresis with SP1 and SP2

You can set a uniform hysteresis area for each of the switch points SP1 (setpoint 1) and SP2 (setpoint 2). Keep in mind that the hysteresis limit for Window mode and Centered Window mode has an outward-facing effect.

The position measurement system accepts a hysteresis range smaller than the zero point or greater than the end of the measuring range as a permissible configuration status. However, it should be noted that the zero point or the end of the measuring range automatically works as a lower or upper switching threshold—instead of the actual hysteresis limit—when the measured value is not met during operation.

The figure below illustrates this.

#### Window with hysteresis area smaller than the zero point

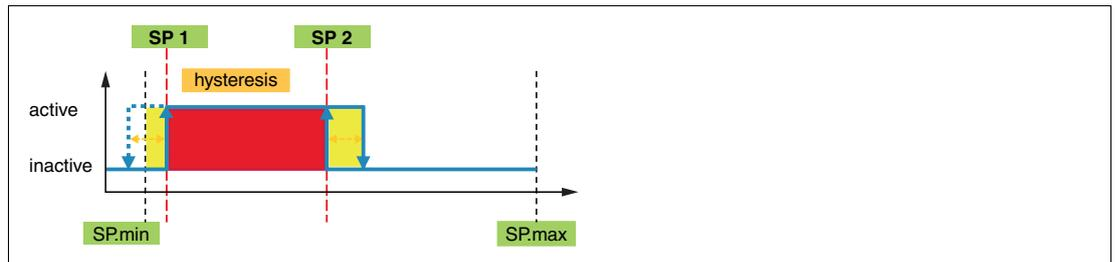

Figure 6.5

The Window mode between the switch points SP2 and SP1 is shown in red. The respective hysteresis area for each switch point is yellow. The ineffective hysteresis range smaller than the zero point is illustrated by the dashed lines.

These switching characteristics apply to Single-Point and Centered Window modes

#### The general rule is:

If the  $SP_n - Hyst$  or  $SP_n - Offset - Hyst$  (Centered Window mode) is smaller than 0 for a decreasing measured value (position), the switch point is at 0.

If  $SP_n + Hyst$  or  $SP_n + Offset + Hyst$  (Centered Window mode only) is greater than the end of the measuring range for an increasing measured value (position), the switch point is at the end of the measuring range.

## **7 Maintenance and Repair**

### **7.1 Maintenance**

The sensor's transmission properties are stable over long periods. For this reason, regular adjustments to, and maintenance on the sensor itself, are not necessary. Nevertheless check in the course of normal maintenance intervals that the sensor, the actuator and the connector are securely attached. Also check that the connecting cable is intact and correctly routed.

### **7.2 Resetting the Output Functions to the Factory Default**

The sensor can be reset via IO-Link only.

## 8 Troubleshooting

### 8.1 What to Do in Case of a Fault

In case of a fault, use the following checklist to determine whether a fault with the sensor can be remedied.

If none of the information provided in the checklist solves the problem, you can contact Pepperl+Fuchs via your sales office with any queries. Have details of the model number and firmware version of the sensor ready if possible.

#### Checklist

Error	Cause	Remedy
No IO-Link connection to device	The C/Q communication port on the sensor is not connected to the IO-Link master.	Make sure the C/Q communication port is connected to the IO-Link master.
	No power supply	Check whether there is a reason for the absence of the power supply (installation or maintenance work, etc.). Switch on the power supply.
	The IO-Link master (if used) is not ready for IO-Link operation.	If used, check the IO-Link master.
Damping element not detected	The distance between the sensor and the damping element is too great.	Check the mounting and establish the correct distance between the sensor and the damping element.

# Your automation, our passion.

## Explosion Protection

- Intrinsic Safety Barriers
- Signal Conditioners
- FieldConnex® Fieldbus
- Remote I/O Systems
- Electrical Ex Equipment
- Purge and Pressurization
- Industrial HMI
- Mobile Computing and Communications
- HART Interface Solutions
- Surge Protection
- Wireless Solutions
- Level Measurement

## Industrial Sensors

- Proximity Sensors
- Photoelectric Sensors
- Industrial Vision
- Ultrasonic Sensors
- Rotary Encoders
- Positioning Systems
- Inclination and Acceleration Sensors
- Fieldbus Modules
- AS-Interface
- Identification Systems
- Displays and Signal Processing
- Connectivity

### Pepperl+Fuchs Quality

Download our latest policy here:

[www.pepperl-fuchs.com/quality](http://www.pepperl-fuchs.com/quality)

