

ICA-8IO-4M4-G20-IO-P14

**IO-Link
Motor Control Module**

Manual

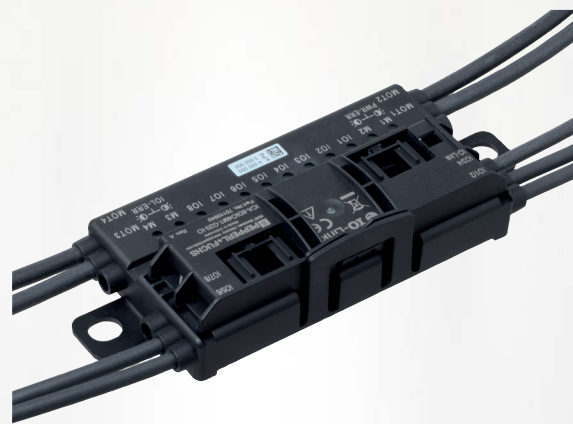

Your automation, our passion.

PEPPERL+FUCHS

With regard to the supply of products, the current issue of the following document is applicable:
The General Terms of Delivery for Products and Services of the Electrical Industry, published
by the Central Association of the Electrical Industry (Zentralverband Elektrotechnik und Elek-
troindustrie (ZVEI) e.V.) in its most recent version as well as the supplementary clause:
"Expanded reservation of proprietorship"

Worldwide

Pepperl+Fuchs Group
Lilienthalstr. 200
68307 Mannheim
Germany
Phone: +49 621 776 - 0
E-mail: info@de.pepperl-fuchs.com

North American Headquarters

Pepperl+Fuchs Inc.
1600 Enterprise Parkway
Twinsburg, Ohio 44087
USA
Phone: +1 330 425-3555
E-mail: sales@us.pepperl-fuchs.com

Asia Headquarters

Pepperl+Fuchs Pte. Ltd.
P+F Building
18 Ayer Rajah Crescent
Singapore 139942
Phone: +65 6779-9091
E-mail: sales@sg.pepperl-fuchs.com
<https://www.pepperl-fuchs.com>

1	Introduction	4
1.1	Content of this Document.....	4
1.2	Target Group, Personnel	4
1.3	Symbols Used	4
1.4	General Safety Information.....	5
1.5	Declaration of Conformity.....	5
2	Product Description	7
2.1	Use and Application	7
2.2	Housing.....	9
2.3	LED Indicators	10
2.4	Interfaces and Connections	11
2.5	Interface Properties.....	12
2.6	Braking Energy Power Feedback	13
3	Installation	14
3.1	Storage and Transportation	14
3.2	Unpacking	14
3.3	Mounting.....	14
3.4	Connecting the Auxiliary Current Flat Cable	14
3.5	Connecting Motors and Sensors	18
4	Repair and Servicing	20
5	Firmware Updates	21
6	Appendix	22
6.1	ASCII Table	22

1 Introduction

1.1 Content of this Document

This document contains information required to use the product in the relevant phases of the product life cycle. This may include information on the following:

- Product identification
- Delivery, transport, and storage
- Mounting and installation
- Commissioning and operation
- Maintenance and repair
- Troubleshooting
- Dismounting
- Disposal



Note

For full information on the product, refer to the further documentation on the Internet at www.pepperl-fuchs.com.



Note

For specific device information such as the year of construction, scan the QR code on the device. As an alternative, enter the serial number in the serial number search at www.pepperl-fuchs.com.

The documentation comprises the following parts:

- This document
- Datasheet

In addition, the documentation may comprise the following parts, if applicable:

- EU-type examination certificate
- EU declaration of conformity
- Attestation of conformity
- Certificates
- Control drawings
- Instruction manual
- Functional safety manual
- Other documents

1.2 Target Group, Personnel

Responsibility for planning, assembly, commissioning, operation, maintenance, and dismantling lies with the plant operator.

Only appropriately trained and qualified personnel may carry out mounting, installation, commissioning, operation, maintenance, and dismantling of the product. The personnel must have read and understood the instruction manual and the further documentation.

Prior to using the product make yourself familiar with it. Read the document carefully.

1.3 Symbols Used

This document contains symbols for the identification of warning messages and of informative messages.

Warning Messages

You will find warning messages, whenever dangers may arise from your actions. It is mandatory that you observe these warning messages for your personal safety and in order to avoid property damage.

Depending on the risk level, the warning messages are displayed in descending order as follows:



Danger!

This symbol indicates an imminent danger.

Non-observance will result in personal injury or death.



Warning!

This symbol indicates a possible fault or danger.

Non-observance may cause personal injury or serious property damage.



Caution!

This symbol indicates a possible fault.

Non-observance could interrupt the device and any connected systems and plants, or result in their complete failure.

Informative Symbols



Note

This symbol brings important information to your attention.



Action

This symbol indicates a paragraph with instructions. You are prompted to perform an action or a sequence of actions.

1.4 General Safety Information

Responsibility for planning, assembly, commissioning, operation, maintenance, and dismantling lies with the plant operator.

Installation and commissioning of all devices may be performed only by trained and qualified personnel.

It is dangerous for the user to make changes and/or repairs. Additionally, doing so voids the warranty and excludes the manufacturer from any liability. In the event of any serious errors, stop using the device. Secure the device against unintended operation. To have the device repaired, return it to your local Pepperl+Fuchs representative or your sales center.



Note

Disposal

Electronic waste is dangerous. When disposing of the equipment, observe the current statutory requirements in the relevant country of use and local regulations.

1.5 Declaration of Conformity

This product was developed and manufactured in line with the applicable European standards and directives.



Note

A declaration of conformity can be requested from the manufacturer.

The product manufacturer, Pepperl+Fuchs Group, 68307 Mannheim, Germany, has a certified quality assurance system that conforms to ISO 9001.



2 Product Description

2.1 Use and Application

General

The ICA-8IO-4M4-G20-IO-P14 intelligent motor control module is a field module with eight combined sensor inputs or electronic digital outputs. The four outputs can be used to actuate DC roller motors with operating voltages of 24 V or 48 V. The outputs are optimized for the types:

- Interroll EC310
- Interroll EC5000 24 V AI (20 W/35 W/50 W)
- Interroll EC5000 48 V AI (20 W/35 W/50 W)
- Rulmeca BL3
- Itoh Denki PM500XK
- Itoh Denki PM500XC

The compact housing is installed directly into support profiles or cable ducts. The voltage supply U_{PWR} is provided by piercing technology. The swiveling flat cable guide locks using a snap-fit without the use of tools.

The combined inputs and outputs and the motor outputs are connected using cable outputs with round M8 plug connectors. The inputs and outputs have 4-pin cable sockets with knurled screws, while the motor outputs have 5-pin snap-on female cordsets. A cable outlet with a 4-pin circular M12 connector is available for connection to IO-Link. The inputs and outputs are supplied via IO-Link. The motor outputs are supplied from U_{PWR} .

The current switch state or an overload of the inputs or outputs are indicated via the IO LEDs. The M LEDs signal the operating state of the motors (stop/operation/fault).

The module is configured via IO-Link.

Function Configuration Based on IODD

The module has two different process data structures—Standard (STD) and Extended (EXT). Which structure is used depends on the IO-Link device ID that is set. While the standard process data image assigns 8 bytes of input data and 6 bytes of output data, the extended process data image uses 8 bytes of input data and 18 bytes of output data. In addition to the functions of the standard process data image, the extended process data image enables control of the start/stop ramps and continuous, real-time adjustment of the roller motor speed via the process data.



Tip

You can download the corresponding IO-Link parameter datasheet for your device from our website www.pepperl-fuchs.com.

The IO-Link parameter datasheet contains detailed information on the structure and assignment of the process data image.

Digital Inputs and Outputs

To be able to optimally control the roller motor rollers based on conditions in the field environment (e.g., switching signal of a light barrier), the module has 8 freely configurable digital inputs/outputs (PNP). The input characteristic of the inputs corresponds to type 3 in accordance with EN 61131-2. The outputs are resistant to short circuits and overloading.

The module and the digital inputs/outputs are supplied via IO-Link. Each sensor power supply can be loaded with 200 mA.

For details regarding connection, .

Counters

The module has a counter input for connecting an incremental rotary encoder. You can connect a single- or dual-input rotary encoder with a counting frequency of up to 10 kHz.

- A single-input rotary encoder is connected to IO1.
- A dual-input rotary encoder is connected to IO1 and IO2, and takes the direction of rotation into account.

Note

Inverting the input channels affects the counter. If the counting direction is to be reversed for a dual-input rotary encoder, one of the two inputs must be inverted.

The counting function has no effect on how inputs are processed at IO1 and IO2. The input filters are not taken into account for the counting function.

Roller Motors

The roller motors are supplied with power via an external auxiliary voltage. The auxiliary voltage is supplied to the roller motor control module via a flat cable.

- The permissible auxiliary voltage is 18–56 V.
- The maximum continuous current load for each roller motor is 3.5 A. The maximum current consumption of the device is 10 A.
- The following current loads are permitted briefly for each roller motor:
 - 5 A for max. 2 s
 - 7.5 A for max. 0.3 s

The roller motor supply is protected by a fuse.

If a roller motor is connected to a motor output, the output must be configured accordingly. The following statuses are transmitted via the process data:

- Roller motor fault
- Fuse
- Switching on and off
- Direction of rotation
- Velocity¹
- Start/Stop Ramps¹ <Default –¹ Font>

The speed is expressed as a percentage. The output voltage for controlling the roller motor speed is output between the configurable limits. The lower limit corresponds to 0% of the maximum speed, the upper limit corresponds to 100% of the maximum speed.

Braking Function

You can use the process data to activate a brake for each roller motor. An activated brake causes the analog velocity output to be lowered to 0 V after reaching the lower limit. For some roller motors, this is mandatory to activate the brake function. This setting has no effect on Interroll EC310 and EC5000 roller motors, because these roller motors always brake.

Start/Stop Ramps

The configurable ramp duration defines the time from stationary (0%) to maximum speed (100%), or from maximum speed to stationary. When the terminal velocity is lower, the ramp duration is shorter.

1. Depending on the selected process data structure,

General IO-Link Information

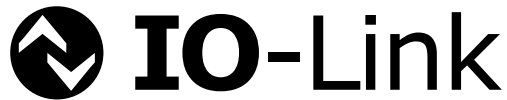

IO-Link is a standardized point-to-point IO technology (IEC 61131-9) between an IO-Link master that controls communication and an IO-Link device that acquires or executes process values at the lowest sensor/actuator level. In addition to transmitting process data, IO-Link also provides access to detailed identification, diagnostics, and parameter data of the respective IO-Link device.

IO-Link uses unshielded 3- or 5-wire cables with a maximum length of 20 meters between the IO-Link master and IO-Link device and enables data transmission rates of 4.8 kbit/s (COM1), 38.4 kbit/s (COM2), or 230.4 kbit/s (COM3). The IO-Link interface is backward compatible with the 24 V I/O signals specified in IEC 61131-2.

2.2 Housing

The housing is made entirely of plastic, except for the hinge pins for the hinge cable guide.

The housing consists of the following main components:

- a mounting base with integrated electronics
- a folding guide cage as a cable guide for the AS-Interface flat cable

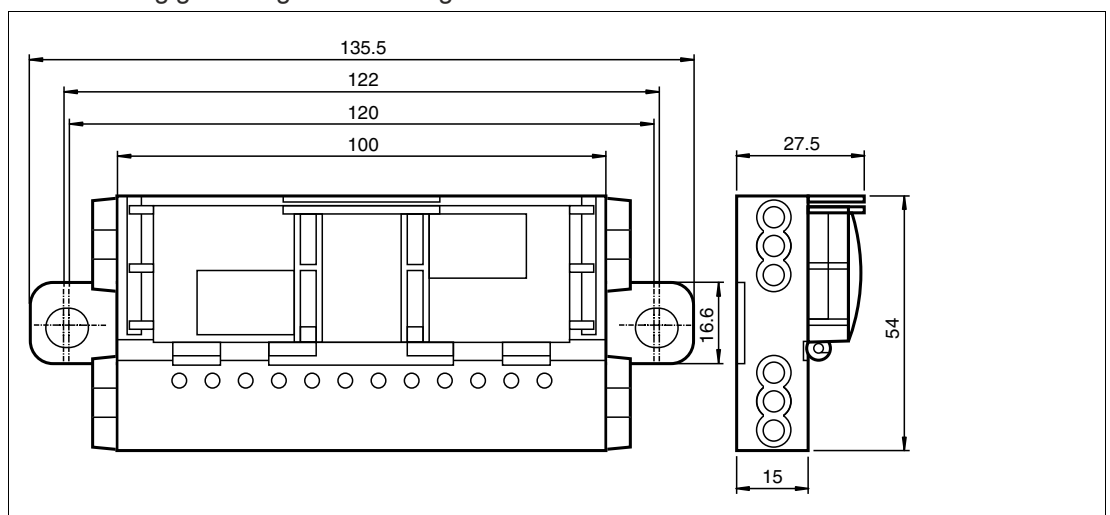

Figure 2.1 Housing dimensions

2.3 LED Indicators

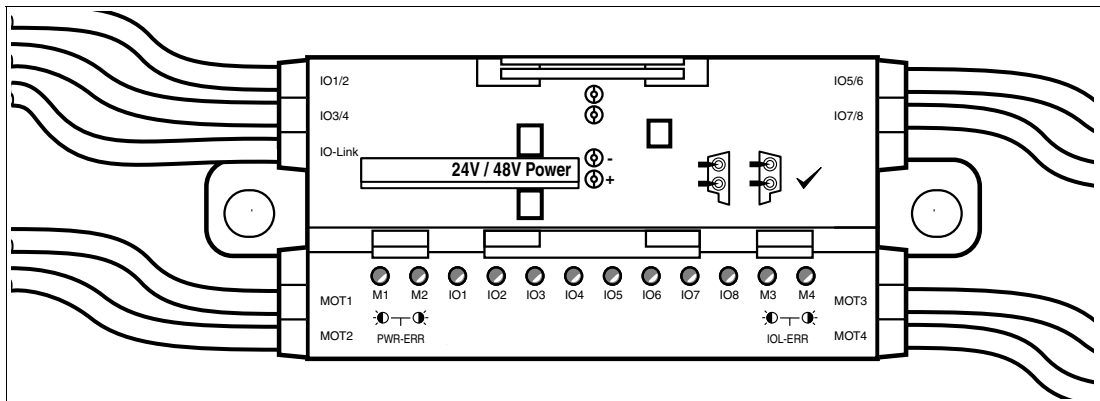

Figure 2.2 LED Indicators

Note

The LEDs on the inputs and outputs indicate the physical state of the respective channel. You can find the invertible logical state of a channel in the process data.

LEDs IO1–IO8

Status	Function
Off	Input/output not active
Yellow lit up	Input/output active
All LEDs flashing red ¹ Yellow unchanged	No communication with IO-Link master State of the input/output
Red lit up	Overload or short circuit of the output or supply
Red or blue illuminating in sequence	No valid firmware or firmware update active

1. Long off, short on

LEDs M1–M4

Status	Function
Off	Motor is not running/output is not active
Yellow	Motor is running/output active (high)
Red flashing	Motor fault (only during motor operation)
Red/yellow flashing	Motor supply fuse faulty (only during motor operation)
MOT3 and MOT4 flashing red alternately	Motor controller is running, but no communication with IO-Link controller <ul style="list-style-type: none"> IO-Link supply not present or firmware update active PWR supply present
MOT1 and MOT2 flashing yellow alternately	IO-Link controller is running, no communication with motor controller <ul style="list-style-type: none"> IO-Link supply present PWR supply not present
MOT3 and MOT4 flashing red	No valid firmware in the motor controller Erroneous firmware update

**Note**

The LEDs MOT1, MOT2, and IO1 to IO8 are supplied from IO-Link; the LEDs MOT3 and MOT4 are supplied from PWR.

**Note**

When all LEDs are in the "off" state, a heartbeat (1.9 s off/0.1 s on) is output via all yellow motor LEDs to signal the general operational readiness of the module.

Flashing pattern for device identification

In the field, a device can be identified by a flashing pattern. The flashing pattern is activated via IO-Link. All LEDs flash in the following pattern:

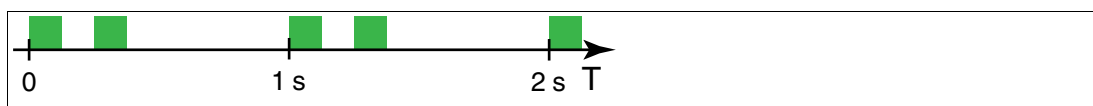

Figure 2.3 Flashing pattern for device identification







2.4 Interfaces and Connections

Flat Cable Specification

The motor control module is compatible with the ASi standard cable in accordance with IEC 62026-2.

The following ASi cable types are available with "UL Recognized" approval:

AS-Interface Cable Types with UL Approval

Pepperl+Fuchs Designation	Color	Sheathing/Wire Insulation Material	Cross section	UL "Cable Style"	Approval
VAZ-FK-R-BK	Black	TPE/TPE	2 x 1.5 mm ²	2103	CE  c 
VAZ-FK-PUR-BK	Black	PUR(TMPU)/TPM	2 x 1.5 mm ²	20549	CE  c 
VAZ-FK-PUR-BK-2.5MM	Black	PUR	2 x 2.5 mm ²	20549 10493	CE  c 

**Warning!**

Observe the maximum permissible operating temperature of the cable.

The maximum permissible operating temperature of the ASi flat cable connected to the module must be at least 80 °C.

Input/Output Connections



The sensors and motors are connected to the motor control module via cables with round M8 connectors:

- Sensors: Socket, 4-pin
- Motors: Socket, 5-pin

Motor Supply from Auxiliary Voltage

The motors are supplied with power directly from the external auxiliary voltage PWR and this cannot be switched. The voltage is always present at contacts 1 and 3 of the 5-pin M8 connector.

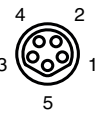
Plug Assignment

Connection for	Connectors	Plug type/assignment
Inputs/outputs		<p>Input: LF004-GS1-A in accordance with IEC/EN 61076-2-104 M8, 4-pin, socket, union nut, A-coded</p> <p>Suitable mating connector: LM004-Gx1-A or similar</p> <p>1: V+ sensor supply 2: IO2, IO4, IO6, IO8 3: V- sensor supply 4: IO1, IO3, IO5, IO7</p>
Motor		<p>Motor: NF005-SS1-B in accordance with IEC/EN 61076-2-104 M8, 5-pin, socket, snap-locking, B-coded</p> <p>Suitable mating connector: NM005-Sx1-B or similar</p> <p>1: MOT+ motor supply 2: DIR direction of rotation 3: MOT- (=PWR-) motor supply 4: ERROR motor fault 5: SPEED speed signal</p>
IO-Link		<p>IO-Link: LM type in accordance with EN 61076-2-101 M12, 4-pin, plug, screw-locking, A-coded</p> <p>Suitable mating connector: LF type or similar</p> <p>1: L+ 2: n.c. 3: L- 4: Q/C</p>

2.5 Interface Properties

Interface type	IO-Link
IO-Link version	1.1
Device Profile	Identification and diagnosis—I&D
Process Data	8 byte inputs (STD/EXT) 6 byte outputs (STD) 18 byte outputs (EXT)
Vendor ID	1 (0x0001)
Device ID	984068 (0x0F0404) (STD) - default 984067 (0x0F0403) (EXT)
Data transfer rate	COM3 (230.4 kbits/s)
Min. cycle time	1.2 ms (STD) 2 ms (EXT)
SIO mode support	No
Compatible master port type	Class A

Standard/Extended

The module has two different process data structures—standard (**STD**) and extended (**EXT**). Which structure is used depends on the IO-Link device ID that is set. While the standard process data image assigns 8 bytes of input data and 6 bytes of output data, the extended process data image uses 8 bytes of input data and 18 bytes of output data. In addition to the functions of the standard process data image, the extended process data image enables control of the start/stop ramps and continuous, real-time adjustment of the roller motor speed via the process data.



Tip

You can download the corresponding IO-Link parameter datasheet for your device from our website www.pepperl-fuchs.com.

The IO-Link parameter datasheet contains detailed information on the structure and assignment of the process data image.

2.6

Braking Energy Power Feedback

The module can conduct electrical energy generated by the roller motor. Note the following maximum values.

Maximum current	4 A per motor
Maximum generated voltage	60 V DC

3 Installation

3.1 Storage and Transportation

Keep the original packaging. Always store and transport the device in the original packaging. Store the device in a clean and dry environment. The permitted ambient conditions must be considered, see datasheet.

3.2 Unpacking

Check the product for damage while unpacking. If the product should be damaged, inform the post office or parcel service and notify the supplier.

Retain the original packaging in case the device must be stored or shipped again at a later date.

Should you have any questions, please contact Pepperl+Fuchs.

3.3 Mounting

Mount the device with both brackets (1) on a solid, continuous surface.

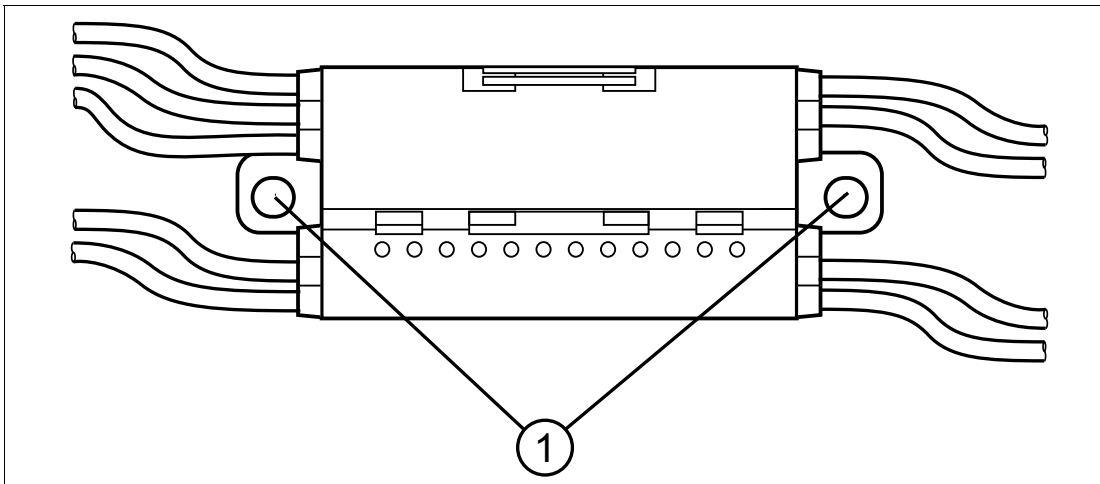

Figure 3.1 Mounting brackets (1)

3.4 Connecting the Auxiliary Current Flat Cable

The motor control module is connected to the PWR auxiliary power supply via the black or gray flat cable. The permissible auxiliary voltage is 18–56 V.



Warning!

Suitable auxiliary voltage

Select a suitable auxiliary voltage for the motor rollers. The motor control module can be operated at 24 V and 48 V. Motor rollers are only designed for one of the two voltages. An unsuitable auxiliary voltage can damage the motor rollers.

Contact between the motor control module and flat cables is established via two metal piercing pins and requires insulation piercing technology. The flat cable is routed through a cable guide with hinges. When closed, the cable guide is locked by a locking bracket and can be opened again without tools.

Flat-profile cables are narrow on top (with visibly offset profile edge) and wide underneath (profile edge not visible). The cable guide allows the flat cables to be inserted on either side, enabling flat cables that are already laid in cable ducts to be connected flexibly. However, it is important to ensure that the profile edge always points toward the motor control module. The mechanical reverse polarity protection prevents the cable guide from closing completely if the flat cable is inserted incorrectly.

**Caution!**

If a flat cable is inserted incorrectly, the motor control module will not work.

If the flat cable is inserted in the cable guide in the wrong direction, the voltage is inverted. The motor control module will not work. However, the internal electrical reverse polarity protection protects it from damage.

**Warning!**

Damage to contacts

Only connect or disconnect the module connections when the module is de-energized. Otherwise, the connections could be damaged.

**Connecting Flat Cables on the Narrow Side**

The profile edge is visible from above.

1. Open the cable guide by pushing the locking bracket (1) slightly to the side.
2. Insert the black PWR flat cable with the profile edge (3) pointing toward the motor control module into the lower duct (see the "24V/48V Power" marking on the module).
3. Make sure that the profile edges of the flat cable are beneath the corresponding reverse polarity protection (2).

**Tip**

Use the mounting aid VAZ-G20-MH to facilitate closing the cable guide.

4. Close the cable guide. It must engage securely in the locking bracket (1).
↳ The metal piercing pins touch the finely stranded wires in the flat cable.

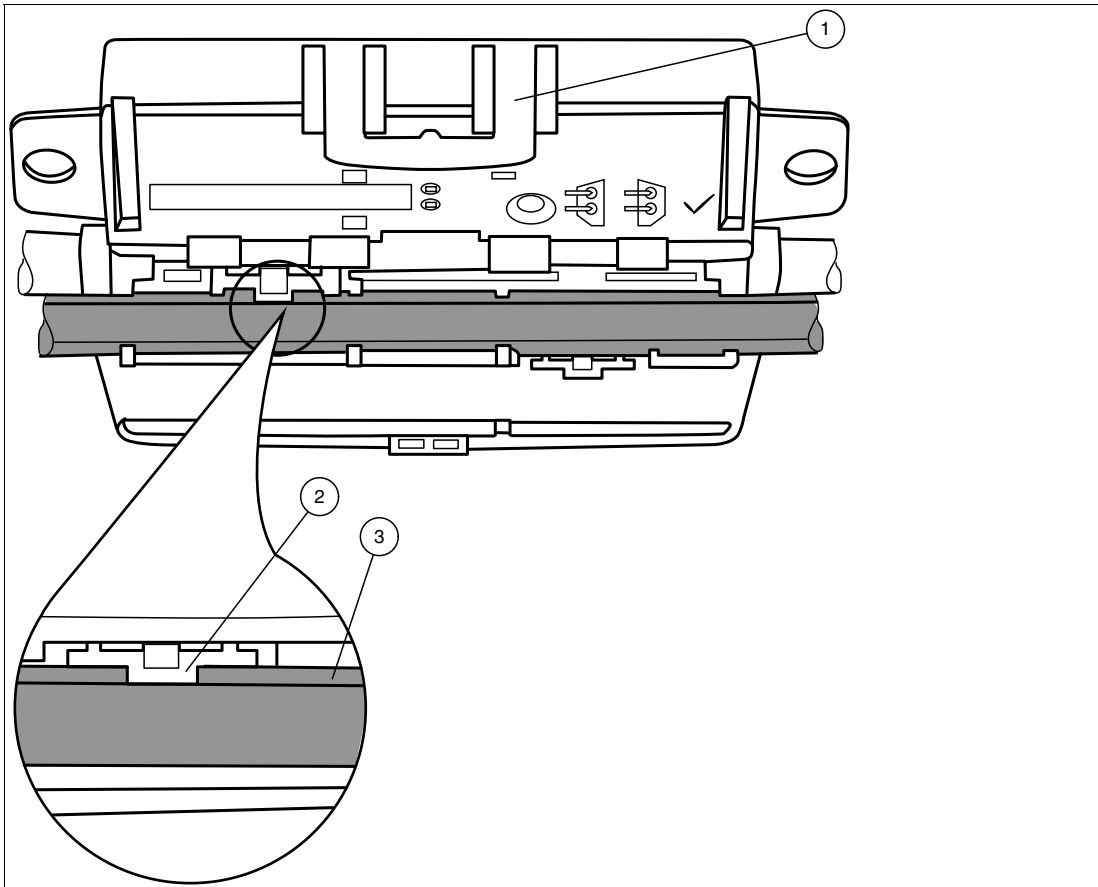

Figure 3.2 Connecting the flat cable on the narrow side



Connecting the Flat Cable on the Wide Side

The profile edge is not visible from above. For clarity in the figure below, a dotted line represents where the edge would be.

1. Open the cable guide by pushing the locking bracket (1) slightly to the side.
2. Insert the black PWR flat cable with the profile edge (2) pointing toward the motor control module into the lower duct (see the "24V/48V Power" marking on the module).



Tip

Use the mounting aid VAZ-G20-MH to facilitate closing the cable guide.

- 3. Close the cable guide. It must engage securely in the locking bracket (1).

↳ The profile edge (2) of the flat cable is above the two reverse polarity protections. The metal piercing pins touch the finely stranded wires in the flat cable.

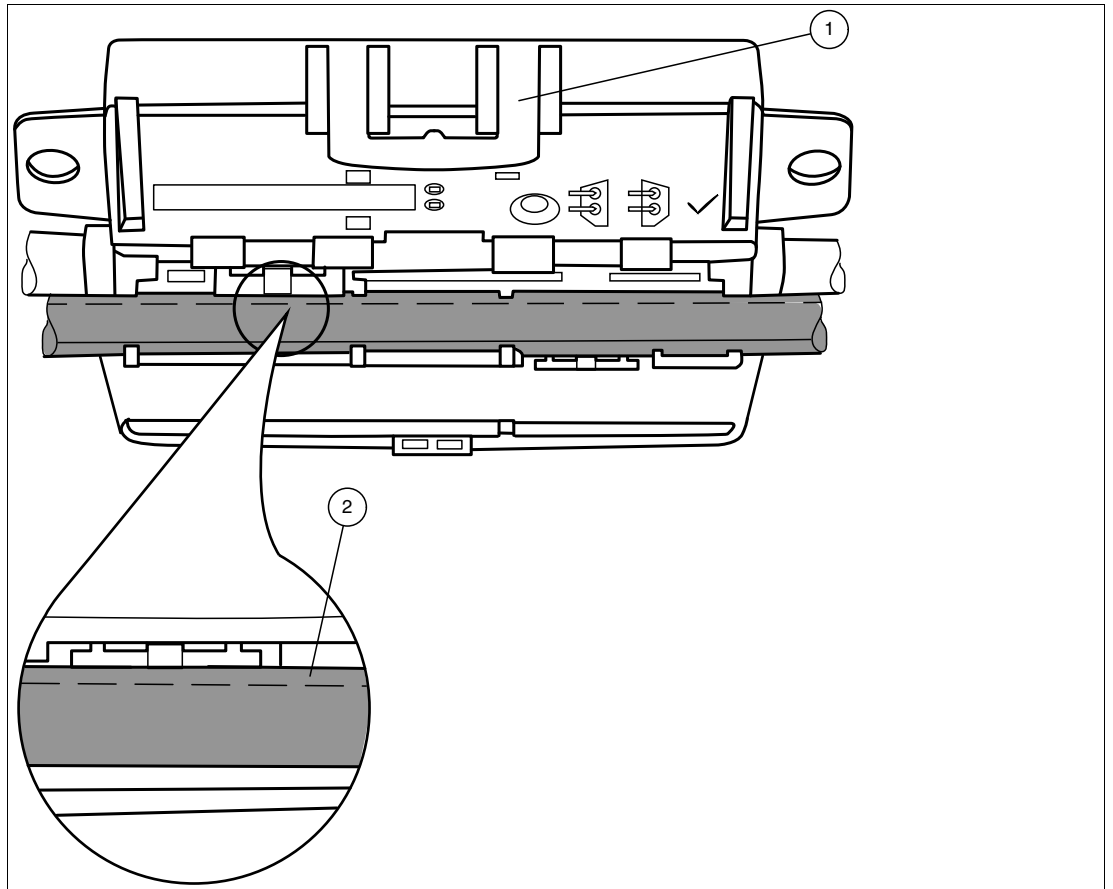

Figure 3.3 Connecting the flat cable on the wide side (profile edge shown as dotted line)

Flat Cable Inserted Incorrectly

The figure below shows an example where the flat cable has been inserted incorrectly. The profile edge (2) does not point toward the motor control module, so the flat cable is inserted with reverse polarity. The flat cable is curved and positioned above the reverse polarity protection (1), which means that the cable guide cannot be closed completely (mechanical reverse polarity protection).

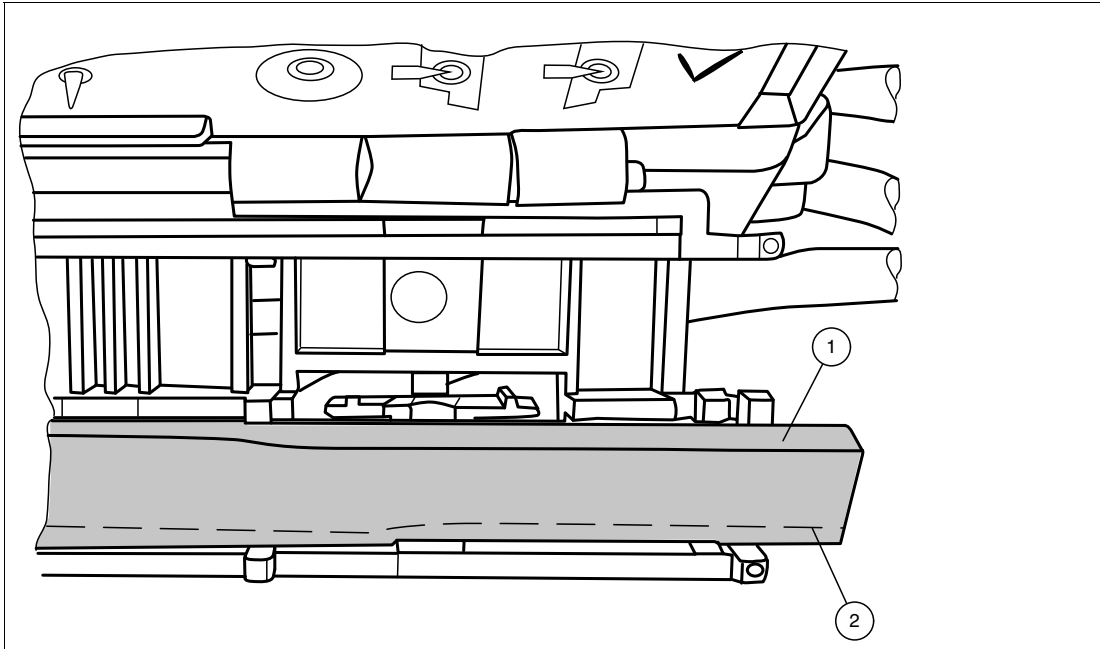

Figure 3.4 Flat cable inserted incorrectly (profile edge shown as dotted line)

3.5 Connecting Motors and Sensors

IO-Link, the inputs and outputs, and the motors are connected via standard round plug connectors.

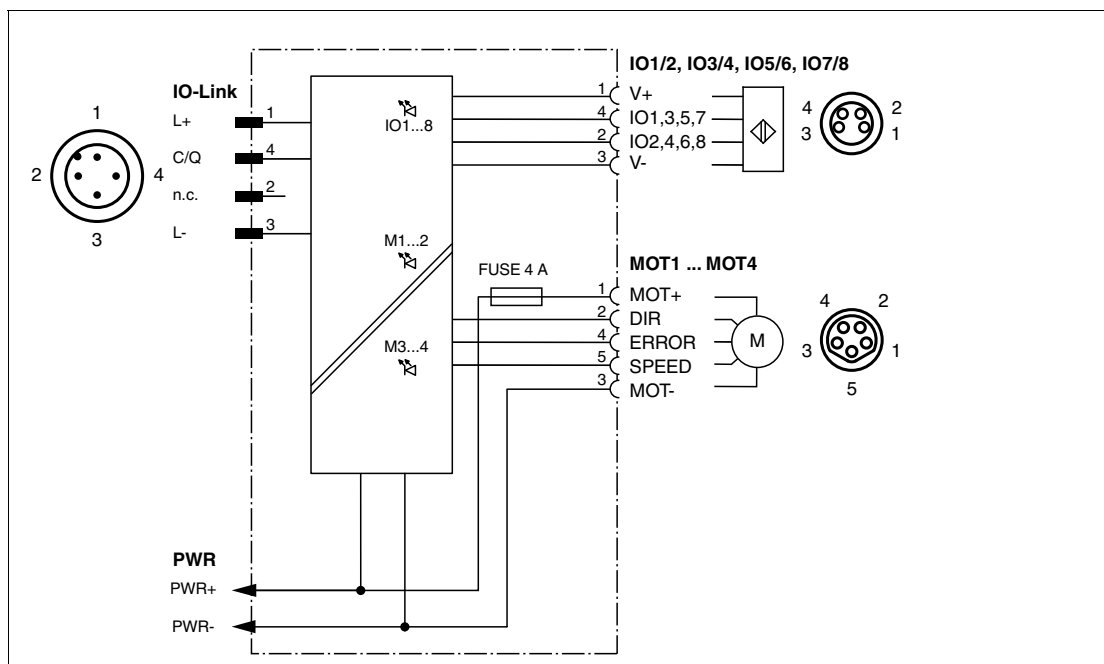

Figure 3.5 Connection wiring diagram for motors and sensors



Warning!

Damage to contacts

Only connect or disconnect the module connections when the module is de-energized. Otherwise, the connections could be damaged.

4 Repair and Servicing

The device must not be repaired, changed, or manipulated. In case of failure, always replace the device with an original device.

5 Firmware Updates

The device supports firmware updates via IO-Link in accordance with the standardized IO-Link firmware update profile IOLFW. The IOLFW files can be found on the detail page for your product, at www.pepperl-fuchs.com.

You can use an IO-Link device tool or other software that supports firmware updates, such as PortVision DX, to perform firmware updates.

For more information on the update process, refer to the product documentation for your IO-Link master or the software you are using.

6 Appendix

6.1 ASCII Table

hex	dec	ASCII	hex	dec	ASCII	hex	dec	ASCII	hex	dec	ASCII
00	0	NUL	20	32	Space	40	64	@	60	96	'
01	1	SOH	21	33	!	41	65	A	61	97	a
02	2	STX	22	34	"	42	66	B	62	98	b
03	3	ETX	23	35	#	43	67	C	63	99	c
04	4	EOT	24	36	\$	44	68	D	64	100	d
05	5	ENQ	25	37	%	45	69	E	65	101	e
06	6	ACK	26	38	&	46	70	F	66	102	f
07	7	BEL	27	39	'	47	71	G	67	103	g
08	8	BS	28	40	(48	72	H	68	104	h
09	9	HT	29	41)	49	73	I	69	105	i
0A	10	LF	2A	42	*	4A	74	J	6A	106	j
0B	11	VT	2B	43	+	4B	75	K	6B	107	k
0C	12	FF	2C	44	,	4C	76	L	6C	108	l
0D	13	CR	2D	45	-	4D	77	M	6D	109	m
0E	14	SO	2E	46	.	4E	78	N	6E	110	n
0F	15	SI	2F	47	/	4F	79	O	6F	111	o
10	16	DLE	30	48	0	50	80	P	70	112	p
11	17	DC1	31	49	1	51	81	Q	71	113	q
12	18	DC2	32	50	2	52	82	R	72	114	r
13	19	DC3	33	51	3	53	83	S	73	115	s
14	20	DC4	34	52	4	54	84	T	74	116	t
15	21	NAK	35	53	5	55	85	U	75	117	u
16	22	SYN	36	54	6	56	86	V	76	118	v
17	23	ETB	37	55	7	57	87	W	77	119	w
18	24	CAN	38	56	8	58	88	X	78	120	x
19	25	EM	39	57	9	59	89	Y	79	121	y
1A	26	SUB	3A	58	:	5A	90	Z	7A	122	z
1B	27	ESC	3B	59	;	5B	91	[7B	123	{
1C	28	FS	3C	60	<	5C	92	\	7C	124	
1D	29	GS	3D	61	=	5D	93]	7D	125	}
1E	30	RS	3E	62	>	5E	94	^	7E	126	~
1F	31	US	3F	63	?	5F	95	_	7F	127	DEL

Your automation, our passion.

Explosion Protection

- Intrinsic Safety Barriers
- Signal Conditioners
- FieldConnex® Fieldbus
- Remote I/O Systems
- Electrical Ex Equipment
- Purge and Pressurization
- Industrial HMI
- Mobile Computing and Communications
- HART Interface Solutions
- Surge Protection
- Wireless Solutions
- Level Measurement

Industrial Sensors

- Proximity Sensors
- Photoelectric Sensors
- Industrial Vision
- Ultrasonic Sensors
- Rotary Encoders
- Positioning Systems
- Inclination and Acceleration Sensors
- Fieldbus Modules
- AS-Interface
- Identification Systems
- Displays and Signal Processing
- Connectivity

Pepperl+Fuchs Quality

Download our latest policy here:

www.pepperl-fuchs.com/quality

