

Terminal Boxes GR.T* Glass Fiber Reinforced Polyester

Marking

Terminal Boxes, Glass-fiber reinforced polyester (GRP) GR.T*
ATEX certificate: CML 17 ATEX 3255X ATEX marking:  II 2 GD Ex eb IIC T* Gb Ex ia IIC T* Gb Ex tb IIIC T** °C Db T6/T80 °C @ Ta +40 °C T5/T95 °C @ Ta +55 °C T4/T130 °C @ Ta +65 °C
IECEx certificate: IECEx CML 17.0144X CCC certificate: 2020322303002568 ETL certificate: Intertek 5003368 , Intertek 5022079 approved for: Class I, Division 2, Groups A, B, C, D Class II, Division 2, Groups F, G Class III cETLus according to: UL 1773 , UL 121201 , CSA C22.2, No. 40, 213

The *-marked letters of the type code are placeholders for versions of the device.

Pepperl+Fuchs Group Lilienthalstraße 200, 68307 Mannheim, Germany
Internet: www.pepperl-fuchs.com

Target Group, Personnel

Responsibility for planning, assembly, commissioning, operation, maintenance, and dismantling lies with the plant operator.

The personnel must be appropriately trained and qualified in order to carry out mounting, installation, commissioning, operation, maintenance, and dismantling of the device. The trained and qualified personnel must have read and understood the instruction manual.

Reference to Further Documentation

Observe directives, standards, and national laws applicable to the intended use and the operating location.

The corresponding datasheets, manuals, declarations of conformity, EU-type examination certificates, certificates, and control drawings if applicable (see datasheet) are an integral part of this document. You can find this information under www.pepperl-fuchs.com.

In order to access this documentation, enter the product name, i. e. the type code, or the item number of the product in the search field of the website.

For specific device information such as the year of construction, scan the QR code on the device. As an alternative, enter the serial number in the serial number search at www.pepperl-fuchs.com.

Intended Use

The device is only approved for appropriate and intended use. Ignoring these instructions will void any warranty and absolve the manufacturer from any liability.

The enclosures of the GR* series are made of Glass fiber reinforced polyester (GRP).

The device can be used indoors.

The device can be used outdoors.

The device can be used in Zone 1.

The device can be used in Zone 21.

The device can be used in Zone 2.

The device can be used in Zone 22.

The device is designed for wall mounting.

The device is designed for mounting to a steel framework.

Use suitable fixing material for mounting.

Mount the enclosure at the fixing points provided.

The terminal boxes are used to distribute electrical energy and electrical signals in hazardous areas. They must be installed in fixed installations.

Improper Use

Do not mount the device on the ceiling.

Protection of personnel and the plant is not ensured if the device is not used according to its intended use.

Mounting and Installation

Observe the installation instructions according to IEC/EN 60079-14.

Observe directives, standards, and national laws applicable to the intended use and the operating location.

Examples for such regulations are regulations regarding electricity, grounding, installation as well as hygiene and safety.

If you intend to install the device or enclosure in areas that may be exposed to aggressive substances, ensure that the stated surface materials are compatible with these substances. If required, contact Pepperl+Fuchs for further information.

Ensure that the device provides and maintains a degree of protection of at least IP66 according to IEC/EN 60079-0.

Observe the requirements according to IEC/EN 60079-31 regarding excessive dust deposits.

To ensure compliance with the temperature class, ensure that there is adequate free air space around the enclosure.

Ensure that there are no external heat sources around the enclosure.

Safety-relevant markings are found on the nameplate supplied. Ensure that the nameplate is present and legible. Take the ambient conditions into account.

Additional warning markings may be affixed next to the nameplate.

The permitted ambient temperatures of the built-in components must not be exceeded.

Ensure that the enclosure is not damaged, distorted, or corroded.

Ensure that all seals are clean, undamaged, and correctly fitted.

Ensure that unused terminal screws are properly tightened down.

Tighten all screws of the enclosure/enclosure cover with the appropriate torque.

Close all unused enclosure holes with the appropriate stopping plugs.

Only use stopping plugs that are suitably certified for the application.

If mounting the enclosure on concrete use expansion anchors. When mounting the enclosure to a steel framework use vibration resistant mounting material.

Ensure that the enclosure is mounted on a flat surface. This prevents the deformation of the enclosure and ensures the safe sealing function of the cover seal.

If external connections are present, ensure that the connections are in good condition, and are not damaged or corroded.

In order to prevent condensation in the enclosure, use suitably certified breather drains.

Installation Sequence

Use the thru-holes for the enclosure mounting. These thru-holes must be accessible when the cover is removed.

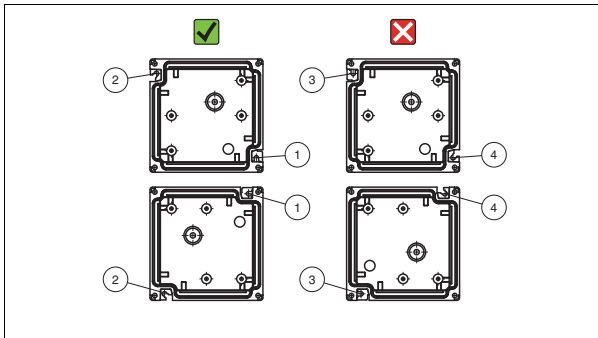

Use all existing screw holes for mounting the enclosure.

It is recommended to use screws according to ISO 4762 or equivalent.

Take note of the various designs of the mounting holes.

Mount the enclosure by doing the following:

- Screw numbers are shown beside the mounting holes.
- Mount the enclosure with the appropriate mounting holes in position (1) and (2).
- Do not mount the enclosure with shown mounting holes in position (3) and (4).
- For easier installation, screws (1) and (2) can be drilled into the wall and the enclosure attached loosely to them prior to fixing all other screws. Screw numbers are shown beside the mounting holes.
- Tighten all mounting screws with the appropriate torque.

i Note

GR.13.18.* , GR.18.18.* and GR.18.24.* show hole (2) being circular instead of a slot. In this case, fix the enclosure with one hand and screw (1) before marking the other hole positions.

i Note

Torque moments depend on the used screws and the material where they are screwed into.

Requirements for Cable Glands

Only use cable glands that are suitably certified for the application.

Only use cable glands with a temperature range appropriate to the application.

For cable glands only use incoming cable diameters of the appropriate size.

Use seals that are suitable for the specified application.

Ensure that the degree of protection is not violated by the cable glands.

Install cables and cable glands in a way that they are not exposed to mechanical hazards.

The cables and connection lines must be free from mechanical stress. Use appropriate strain relief, which must be fitted outside of the enclosure.

Ensure that all cable glands are in good condition and are securely tightened.

Close all unused cable glands with the appropriate sealing plugs.

Observe the specific ambient conditions of sealing plugs.

Tighten all cable glands with the appropriate torque.

Ground metal cable glands.

Requirements for Internal Components

In order to guarantee the temperature classes, ensure that power dissipation is lower than the figure stated in the certificate. Most of the power dissipation arises from current flowing in the cables.

If you install the devices in ambient temperatures above +40 °C, the temperature at the cable glands may exceed the ambient temperature by 40 K when the maximum allowed power is dissipated.

Only use cables and connection lines with a temperature range appropriate to the application.

Keep the separation distances between all non-intrinsically safe circuits and intrinsically safe circuits according to IEC/EN 60079-14.

Only use suitably certified terminals.

Ensure that the terminals are in good condition and are not damaged or corroded.

The terminals may have several connections.

Only use one connection per terminal in this application.

Observe the tightening torque of the terminal screws.

Use the shortest possible cable lengths and avoid small core cross sections.

Use only one conductor per terminal.

Observe the minimum bending radius of the conductors.

When installing the conductors the insulation must reach up to the terminal.

When using stranded conductors, crimp wire end ferrules on the conductor ends.

Unused cables and connection lines must be either connected to terminals or securely tied down and isolated.

Insulation by tape alone is not permitted.

The use of jumpers may reduce the maximum permissible voltage of the device. Only use jumpers are listed in the certificate of the terminal manufacturer.

Observe the instruction manual and the certificate of the installed apparatus.

Refer to the corresponding technical data of the installed components for the actual type of protection or any possible restrictions.

Do not bunch more than 6 conductors to avoid hot spots.

Arrange the earth connections for incoming and outgoing cables in a way that the ground fault current is not routed between separate grounding plates.

Contact Pepperl+Fuchs before installing additional components. Pepperl+Fuchs will check whether these components are listed in the certificate. The maximum power dissipation of this installation solution must be within the permitted limits.

Do not install fuse terminals, relays, miniature circuit breakers, contactors etc. in the enclosure.

Rules for installing additional terminals

The following rules apply only to ATEX / IECEx solutions.

It is allowed to add terminals in accordance with the maximum permitted power dissipation. For calculation and terminal capacity tables please refer to section 'Maximum Terminal Capacity'.

Rules for bringing in additional thru-holes for cable glands

Determine if the space needed for the additional holes does not affect the stability of the enclosure wall and therefore the effectiveness of the gasket system.

In case of doubts contact Pepperl+Fuchs.

Maintain the minimum distances to enclosure rims and bottom as shown in the drawings.

Thru-holes for plain entries must have a diameter of not more than 0.7 mm greater than the nominal diameter of the entry thread of cable gland or fitting.

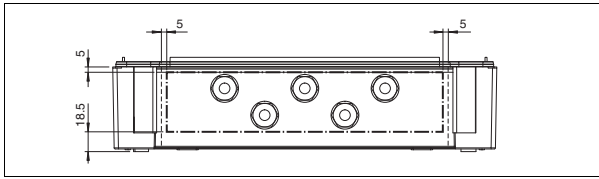

Calculate the minimum distance from the center of the additional thru-hole to the center of an already existing adjacent thru-hole by means of one of the following formulas:

1. Calculation via diameters

HSN = diameter of adjacent thru-hole

HSA = diameter of additional thru-hole

Minimum distance between centers = $1.5 \times (HSN+HSA)/2$

2. Calculation via widths across corners

WCN = width across corners of adjacent cable gland

WCA = width across corners of additional cable gland

Minimum distance between centers = $1.2 \times (WCN+WCA)/2$

Fabricate the additional thru-holes with an appropriate tooling method.

Ensure the thru-hole diameters are fitting to the gaskets and cable glands to be installed.

Ensure the enclosure surfaces around the thru-holes are undamaged in order to maintain the IP-protection.

Operation, Maintenance, Repair

Observe the requirements according to IEC/EN 60079-14 during operation.

Observe IEC/EN 60079-17 for maintenance and inspection.

Observe the requirements according to IEC/EN 60079-19 for repair and overhaul.

Before opening the enclosure make sure that the built-in components are de-energized.

When energized, the enclosure may only be opened for maintenance, if only intrinsically safe circuits are used inside the enclosure.

Check the wear on the device and the device components at specific intervals. The interval between checks depends on the operating conditions and loads that occur.

Avoid electrostatic charges which could result in electrostatic discharges while installing, operating, or maintaining the device.

If cleaning is necessary while the device is located in a hazardous area, in order to avoid electrostatic charging only use a clean damp cloth.

Ensure that all fasteners are present.

Ensure that external ground connections exist, are in good condition, and are not damaged or corroded.

Before assembly, check that the seal and sealing surface are clean and in good condition to ensure the degree of protection.

If there is a defect, the device must be repaired by Pepperl+Fuchs.

Alternatively the device can be repaired by a qualified electrician in compliance with IEC/EN 60079-19.

Delivery, Transport, Disposal

Store the device in a clean and dry environment. The permitted ambient conditions must be considered, see datasheet.

Check the packaging and contents for damage.

Check if you have received every item and if the items received are the ones you ordered.

The device, built-in components, packaging, and any batteries contained within must be disposed in compliance with the applicable laws and guidelines of the respective country.

Technical Data

General	
Types and variants	GR.T* - see type code table
Electrical specifications	
Operating voltage	690 V AC / DC max. depending on size for ATEX / IECEx 600 V AC / DC max. for North American approvals Dependent on terminals and equipment fitted, but must not exceed maximum. (GR.TB.10.10.09*: 440V AC max.) See certification label
Operating current	350 A max. depending on size and certification Dependent on terminals and equipment fitted, but must not exceed maximum. (GR.TB.10.10.09*: 35 A max.) See certification label
Mechanical specifications	
Dimensions	see data table
Enclosure cover	fully detachable, optional hinges
Cover fixing	stainless steel combination Phillips and slotted screw, see data table
Degree of protection	IP66, Type 4X
Mass	see data table valid for empty enclosure, will increase according to integrated components
Mounting	see data table
Cable entry	see data table
Material	
Enclosure	carbon loaded, antistatic glass-fiber reinforced polyester (GRP)
Finish	inherent color black
Cover seal	foamed silicone
Grounding plate	2 mm brass optional
Grounding	none as standard optional M6 or M8 internal/external brass nickel-plated grounding bolt optional M6 or M8 internal/external stainless steel grounding bolt
Ambient conditions	
Ambient temperature	-40 ... 55 °C -60 ... 65 °C (-76 ... 149 °F) depending on integrated components below -40 °C with appropriate cable glands
Data for application in connection with hazardous areas	
Maximum power dissipation	Dependent on enclosure size See certification label
Conformity	
Degree of protection	EN60529 and UL 50 / UL 50E
CE marking	0102

Type Code / Model Number

1	2	3	4	5	6	7	8						
GR	.	*	.	*	.	*	*						
GR	.	TBI	.	13	.	18	.	09	.	B	.	S	0001

Example: GR.TBI.13.18.09.B-S0001

Terminal box, material glass fiber reinforced polyester, for intrinsically safe circuits, size 13x18x9 cm, landscape orientation with face B at bottom, standard device

1	Enclosure type
GR	glass fiber reinforced polyester (GRP)

2	Type of solution
TJE	junction box (Ex e)
TJI	junction box (Ex i)
TBE	terminal box (Ex e)
TBI	terminal box (Ex i)
TBM	terminal box, various types of explosion protection, e.g. (Ex e, Ex i) or (Ex e, Ex op pr)
TB1	terminal box with one terminal

3	Height [cm]
n	see dimensions data table

4	Width [cm]
n	see dimensions data table

5	Depth [cm]
n	see dimensions data table

6	Cable entry face orientation
B	face [B] at bottom (landscape with rectangular enclosure)
D	face [D] at bottom (portrait with rectangular enclosure)

7	Variant
S	standard product
C	configured product
CA	configured and adapted product
Y	engineered product

8	Variant number
*	consecutive item number

Variant-Specific Data

Dimensions and Enclosure Details

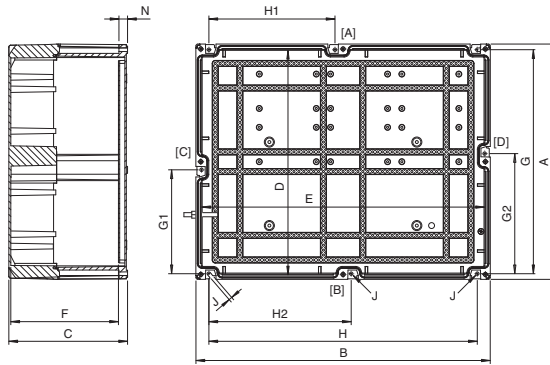

Type	External dimensions [mm]			Internal dimensions [mm]			Mounting [mm]							Mass [kg]	Cover screws				
	A	B	C	D	E	F	G	G1	G2	H	H1	H2	J		N	S qty.	Mx	qty.	T [Nm]
GR*.10.10.07	99	99	65	76	76	48	66	-	-	84	-	-	5	13	2	0.35	M4	4	1.5
GR*.13.13.09	129	129	85	106	106	68	96	-	-	114	-	-	5	13	2	0.61	M4	4	1.5
GR*.13.18.09	129	179	91.5	106	156	69	106	-	-	126	-	-	7	18	2	1	M6	4	3.5
GR*.18.18.10	179	179	104	156	156	81.5	126	-	-	156	-	-	7	18	2	1.35	M6	4	3.5
GR*.18.24.10	179	239	104	156	216	81.5	156	-	-	186	-	-	7	18	2	1.65	M6	4	3.5
GR*.18.36.10	179	359	104	156	336	81.5	156	-	-	306	-	-	7	18	4	2.3	M6	4	3.5
GR*.18.36.17	179	359	166.5	156	336	144	156	-	-	306	-	-	7	18	4	3.1	M6	4	3.5
GR*.36.36.10	359	359	104	336	336	81.5	306	-	-	336	-	-	7	18	4	3.7	M6	4	3.5
GR*.36.36.17	359	359	166.5	336	336	144	306	-	-	336	-	-	7	18	4	4.6	M6	4	3.5
GR*.36.36.24	359	359	241.5	336	336	219	306	-	-	336	-	-	7	18	4	6.6	M6	4	3.5
GR*.36.72.17	359	719	166.5	336	696	144	336	-	-	666	316.5	349.5	7	18	6	8.3	M6	6	3.5
GR*.36.72.24	359	719	241.5	336	696	219	33	-	-	666	316.5	349.5	7	18	6	11.3	M6	6	3.5
GR*.48.60.24	479	599	241.5	456	576	219	456	211.5	244.5	546	256.5	289.5	7	18	8	12.2	M6	8	3.5

S = mounting screws quantity, T = cover screws torque [Nm]

Mass is valid for empty enclosure, it will increase according to enclosure accessories, integrated components and entry devices

Values might differ slightly due to manufacturing tolerances

Brief Instructions

Terminal Configurations with Standard Terminals

Type	DIN-Rails vertical				DIN-Rails horizontal				Terminal type	Terminal capacity [mm ²]
	Number of rails	Usable length per rail [mm]	Terminals per rail	Terminals total	Number of rails	Usable length per rail [mm]	Terminals per rail	Terminals total		
GR*.10.10.07	–	–	–	–	1	47.5	9	9	AKZ	2
GR*.13.13.09	–	–	–	–	1	67.5	13	13	AKZ	2
GR*.13.18.09	1	66.5	13	13	1	101.5	19	19	WDU	2
GR*.18.18.10	1	101.5	19	19	1	101.5	19	19	WDU	2
GR*.18.24.10	1	101.5	19	19	1	161.5	31	31	WDU	2
GR*.18.36.10	3	101.5	19	57	1	281.5	55	55	WDU	2
GR*.18.36.17	3	101.5	19	57	1	281.5	55	55	WDU	2
GR*.36.36.10	3	281.5	55	165	3	281.5	55	165	WDU	2
GR*.36.36.17	3	281.5	55	165	3	281.5	55	165	WDU	2
GR*.36.36.24	3	281.5	55	165	3	281.5	55	165	WDU	2
GR*.36.72.17	6	271.5	53	318	3	641.5	125	375	WDU	2
GR*.36.72.24	6	271.5	53	318	3	641.5	125	375	WDU	2
GR*.48.60.24	5	381.5	74	370	4	501.5	98	392	WDU	2

For other terminal types and terminal capacities please contact Pepperl+Fuchs

Cable Entries max. Quantity per Size

Type	Faces A and B					Faces C and D				
	M16	M20	M25	M32	M40	M16	M20	M25	M32	M40
GR*.10.10.07	4	2	1	1	–	2	1	1	–	–
GR*.13.13.09	9	5	3	2	1	6	4	2	2	1
GR*.13.18.09	11	6	4	2	2	8	4	2	1	1
GR*.18.18.10	15	8	6	3	2	12	6	5	2	2
GR*.18.24.10	20	11	8	4	3	15	8	6	3	2
GR*.18.36.10	30	18	11	6	4	14	8	5	3	2
GR*.18.36.17	60	33	22	15	8	27	15	10	6	4
GR*.36.36.10	35	18	13	7	5	30	18	11	6	4
GR*.36.36.17	69	38	26	18	10	60	33	22	15	8
GR*.36.36.24	69	38	26	18	10	60	33	22	15	8
GR*.36.72.17	129	73	48	35	19	69	38	26	18	10
GR*.36.72.24	129	73	48	35	19	69	38	26	18	10
GR*.48.60.24	102	58	38	26	14	84	45	30	20	12

Cable gland standard type: polyamide Ex e cable glands

For other types of cable glands and combinations of different gland sizes please contact Pepperl+Fuchs

Maximum Terminal Capacity

Maximum number of terminals in relation to the cross-section and the permissible continuous current, based on terminal type WDU.

GR.T*.10.10.07 and GR.T*.13.13.09 based on terminal type AKZ.

Calculation of terminals quantities:

$$\sum_{k=0}^n \frac{\text{installed terminals quantity}}{\text{permitted terminals quantity}} < 1$$

Example:

1. Enclosure type GR.T*.36.36.10
2. 10 x 6 mm² terminals with an application current of 24 A consume 45% of the rated power dissipation [10 (installed terminal quantity) / 22 (permitted terminal quantity)]
3. 20 x 2.5 mm² terminals with an application current of 10 A consume 25% of the rated power dissipation [20 (installed terminal quantity) / 79 (permitted terminal quantity)]
4. Installation of additional 5 terminals with 2.5 mm² and an application current of 10 A will consume 6% of the rated power dissipation
5. 45% + 25% + 6% = 76% < 100%
6. Result: installation of the additional terminals is permissible

The values shown below are those which result in a maximum 40 degrees rise within the enclosure. Please consult with Pepperl+Fuchs for different temperature rises.

When using below tables, the simultaneous factor or the rated load factor in accordance with IEC 60439 must be taken into consideration.

Terminals carrying only intrinsically safe circuits or grounding terminals may be added in any number within the physical capacity of the enclosure

Terminals shall not be installed within the upper 25% of the height of the enclosure.

Enclosure type:	GR.T*.10.10.07					
Maximum permitted power dissipation [W]:	6					
Permitted number of terminals based on terminal capacity and application current:						
Terminal capacity [mm²]						
Current [A]:	1.5	2.5	4	6	10	16
3	9	9	7	-	-	-
5	9	9	7	-	-	-
10	9	9	7	-	-	-
16	5	9	7	-	-	-
20	0	0	7	-	-	-
24	0	0	5	-	-	-
35	0	0	0	-	-	-
50	0	0	0	-	-	-
63	0	0	0	-	-	-

Brief Instructions

Enclosure type:	GR.T*. 13.13.09					
Maximum permitted power dissipation [W]:	8.1					
Permitted number of terminals based on terminal capacity and application current:						
Terminal capacity [mm²]						
Current [A]:	1.5	2.5	4	6	10	16
3	12	12	10	-	-	-
5	12	12	10	-	-	-
10	12	12	10	-	-	-
16	6	10	10	-	-	-
20	0	0	10	-	-	-
24	0	0	6	-	-	-
35	0	0	0	-	-	-
50	0	0	0	-	-	-
63	0	0	0	-	-	-

Enclosure type:	GR.T*. 13.18.09					
Maximum permitted power dissipation [W]:	9.7					
Permitted number of terminals based on terminal capacity and application current:						
Terminal capacity [mm²]						
Current [A]:	1.5	2.5	4	6	10	16
3	19	19	16	12	9	8
5	19	19	16	12	9	8
10	19	19	16	12	9	8
16	6	10	16	12	9	8
20	0	0	16	12	9	8
24	0	0	6	12	9	8
35	0	0	0	2	6	8
50	0	0	0	0	0	8
63	0	0	0	0	0	2

Enclosure type:	GR.T*. 18.18.10					
Maximum permitted power dissipation [W]:	12.3					
Permitted number of terminals based on terminal capacity and application current:						
Terminal capacity [mm²]						
Current [A]:	1.5	2.5	4	6	10	16
3	19	19	16	12	9	8
5	19	19	16	12	9	8
10	19	19	16	12	9	8
16	7	11	16	12	9	8
20	0	0	16	12	9	8
24	0	0	7	12	9	8
35	0	0	0	2	6	8
50	0	0	0	0	0	8
63	0	0	0	0	0	2

Brief Instructions

Enclosure type:	GR.T*.18.24.10					
Maximum permitted power dissipation [W]:	14.5					
Permitted number of terminals based on terminal capacity and application current:						
Terminal capacity [mm²]						
Current [A]:	1.5	2.5	4	6	10	16
3	31	31	26	19	15	13
5	31	31	26	19	15	13
10	31	31	26	19	15	13
16	7	12	26	19	15	13
20	0	0	19	19	15	13
24	0	0	7	19	15	13
35	0	0	0	2	7	13
50	0	0	0	0	0	9
63	0	0	0	0	0	2

Enclosure type:	GR.T*. 18.36.10					
Maximum permitted power dissipation [W]:	18.8					
Permitted number of terminals based on terminal capacity and application current:						
Terminal capacity [mm²]						
Current [A]:	1.5	2.5	4	6	10	16
3	54	54	45	34	27	23
5	54	54	45	34	27	23
10	50	54	45	34	27	23
16	7	12	44	34	27	23
20	0	0	19	34	27	23
24	0	0	7	24	27	23
35	0	0	0	2	7	23
50	0	0	0	0	0	10
63	0	0	0	0	0	2

Enclosure type:	GR.T*. 18.36.17					
Maximum permitted power dissipation [W]:	22.3					
Permitted number of terminals based on terminal capacity and application current:						
Terminal capacity [mm²]						
Current [A]:	1.5	2.5	4	6	10	16
3	54	54	45	34	27	23
5	54	54	45	34	27	23
10	54	54	45	34	27	23
16	8	14	45	34	27	23
20	0	0	22	34	27	23
24	0	0	8	28	27	23
35	0	0	0	3	8	23
50	0	0	0	0	0	11
63	0	0	0	0	0	3

© Pepperl+Fuchs - Subject to modifications / DOCT-9399B - 2026-03

Refer to "General Notes Relating to Pepperl+Fuchs Product Information"

Pepperl+Fuchs Group
www.pepperl-fuchs.com

Tel: +49 621 776-0
E-Mail: info@de.pepperl-fuchs.com



Brief Instructions

Enclosure type:	GR.T* . 36.36.10					
Maximum permitted power dissipation [W]:	31.7					
Permitted number of terminals based on terminal capacity and application current:						
Terminal capacity [mm²]						
Current [A]:	1.5	2.5	4	6	10	16
3	162	162	136	102	82	69
5	162	162	136	102	82	69
10	69	112	136	102	82	69
16	10	17	61	102	82	69
20	0	0	26	63	82	69
24	0	0	10	34	60	69
35	0	0	0	3	9	51
50	0	0	0	0	0	14
63	0	0	0	0	0	3

Enclosure type:	GR.T* . 36.36.17					
Maximum permitted power dissipation [W]:	37					
Permitted number of terminals based on terminal capacity and application current:						
Terminal capacity [mm²]						
Current [A]:	1.5	2.5	4	6	10	16
3	162	162	136	102	82	69
5	162	162	136	102	82	69
10	78	127	136	102	82	69
16	11	19	69	102	82	69
20	0	0	30	71	82	69
24	0	0	11	38	69	69
35	0	0	0	4	11	58
50	0	0	0	0	0	16
63	0	0	0	0	0	3

Enclosure type:	GR.T* . 36.36.24					
Maximum permitted power dissipation [W]:	43.3					
Permitted number of terminals based on terminal capacity and application current:						
Terminal capacity [mm²]						
Current [A]:	1.5	2.5	4	6	10	16
3	162	162	136	102	82	69
5	162	162	136	102	82	69
10	86	142	136	102	82	69
16	12	21	78	102	82	69
20	0	0	33	79	82	69
24	0	0	12	43	77	69
35	0	0	0	4	12	65
50	0	0	0	0	0	18
63	0	0	0	0	0	4

Brief Instructions

Terminal Boxes GR.T* Glass Fiber Reinforced Polyester

Enclosure type:	GR.T* . 36.72.17					
Maximum permitted power dissipation [W]:	61.7					
Permitted number of terminals based on terminal capacity and application current:						
Terminal capacity [mm²]						
Current [A]:	1.5	2.5	4	6	10	16
3	370	370	310	234	188	157
5	370	370	310	234	188	157
10	86	143	300	234	188	157
16	12	21	78	155	188	157
20	0	0	34	81	141	157
24	0	0	12	43	79	157
35	0	0	0	4	12	68
50	0	0	0	0	0	19
63	0	0	0	0	0	4

Enclosure type:	GR.T* . 36.72.24					
Maximum permitted power dissipation [W]:	70.1					
Permitted number of terminals based on terminal capacity and application current:						
Terminal capacity [mm²]						
Current [A]:	1.5	2.5	4	6	10	16
3	370	370	310	234	188	157
5	370	370	310	234	188	157
10	96	159	310	234	188	157
16	13	24	87	172	188	157
20	0	0	37	90	157	157
24	0	0	13	48	88	157
35	0	0	0	4	14	76
50	0	0	0	0	0	21
63	0	0	0	0	0	4

Enclosure type:	GR.T* . 48.60.24					
Maximum permitted power dissipation [W]:	76.8					
Permitted number of terminals based on terminal capacity and application current:						
Terminal capacity [mm²]						
Current [A]:	1.5	2.5	4	6	10	16
3	385	385	323	244	196	164
5	385	385	323	244	196	164
10	109	181	323	244	196	164
16	15	27	99	196	196	164
20	0	0	43	102	179	164
24	0	0	15	55	100	164
35	0	0	0	5	15	86
50	0	0	0	0	0	24
63	0	0	0	0	0	5

© Pepperl+Fuchs - Subject to modifications / DOCT-9399B - 2026-03

Refer to "General Notes Relating to Pepperl+Fuchs Product Information"

Pepperl+Fuchs Group
www.pepperl-fuchs.com

Tel: +49 621 776-0
E-Mail: info@de.pepperl-fuchs.com

