

Functional Safety

SMART Transmitter Power  
Supply  
KFD2-STC5-(Ex)\*

Manual

**SIL**

IEC 61508/61511



**SIL2**  
**SIL3**



---

With regard to the supply of products, the current issue of the following document is applicable:  
The General Terms of Delivery for Products and Services of the Electrical Industry, published by the Central Association of the Electrical Industry (Zentralverband Elektrotechnik und Elektroindustrie (ZVEI) e.V.) in its most recent version as well as the supplementary clause: "Expanded reservation of proprietorship"

#### **Worldwide**

Pepperl+Fuchs Group

Lilienthalstr. 200

68307 Mannheim

Germany

Phone: +49 621 776 - 0

E-mail: [info@de.pepperl-fuchs.com](mailto:info@de.pepperl-fuchs.com)

#### **North American Headquarters**

Pepperl+Fuchs Inc.

1600 Enterprise Parkway

Twinsburg, Ohio 44087

USA

Phone: +1 330 425-3555

E-mail: [sales@us.pepperl-fuchs.com](mailto:sales@us.pepperl-fuchs.com)

#### **Asia Headquarters**

Pepperl+Fuchs Pte. Ltd.

P+F Building

18 Ayer Rajah Crescent

Singapore 139942

Phone: +65 6779-9091

E-mail: [sales@sg.pepperl-fuchs.com](mailto:sales@sg.pepperl-fuchs.com)

<https://www.pepperl-fuchs.com>

- 1 Introduction ..... 5**
  - 1.1 Content of this Document ..... 5**
  - 1.2 Safety Information ..... 6**
  - 1.3 Symbols Used ..... 7**
- 2 Product Description ..... 8**
  - 2.1 Function ..... 8**
  - 2.2 Interfaces ..... 9**
  - 2.3 Marking ..... 9**
  - 2.4 Standards and Directives for Functional Safety ..... 10**
- 3 Planning ..... 11**
  - 3.1 Assumptions ..... 11**
  - 3.2 Safety Function and Safe State ..... 12**
  - 3.3 Characteristic Safety Values ..... 14**
  - 3.4 Useful Lifetime ..... 16**
- 4 Mounting and Installation ..... 17**
  - 4.1 Configuration ..... 17**
- 5 Operation ..... 18**
  - 5.1 Proof Test Procedure ..... 18**
- 6 Maintenance and Repair ..... 21**
- 7 List of Abbreviations ..... 22**



# 1 Introduction

## 1.1 Content of this Document

This document contains information for usage of the device in functional safety-related applications. You need this information to use your product throughout the applicable stages of the product life cycle. These can include the following:

- Product identification
- Delivery, transport, and storage
- Mounting and installation
- Commissioning and operation
- Maintenance and repair
- Troubleshooting
- Dismounting
- Disposal

**Note**

This document does not substitute the instruction manual.

---

**Note**

For full information on the product, refer to the instruction manual and further documentation on the Internet at [www.pepperl-fuchs.com](http://www.pepperl-fuchs.com).

---

**Note**

For specific device information such as the year of construction, scan the QR code on the device. As an alternative, enter the serial number in the serial number search at [www.pepperl-fuchs.com](http://www.pepperl-fuchs.com).

---

The documentation consists of the following parts:

- Present document
- Instruction manual
- Manual
- Datasheet

Additionally, the following parts may belong to the documentation, if applicable:

- EU-type examination certificate
- EU declaration of conformity
- Attestation of conformity
- Certificates
- Control drawings
- FMEDA report
- Assessment report
- Additional documents

For more information about Pepperl+Fuchs products with functional safety, see [www.pepperl-fuchs.com/sil](http://www.pepperl-fuchs.com/sil).

## 1.2 Safety Information

### Target Group, Personnel

Responsibility for planning, assembly, commissioning, operation, maintenance, and dismantling lies with the plant operator.

Only appropriately trained and qualified personnel may carry out mounting, installation, commissioning, operation, maintenance, and dismantling of the product. The personnel must have read and understood the instruction manual and the further documentation.

### Intended Use

The device is only approved for appropriate and intended use. Ignoring these instructions will void any warranty and absolve the manufacturer from any liability.

The device is developed, manufactured and tested according to the relevant safety standards.

Use the device only

- for the application described
- with specified environmental conditions
- with devices that are suitable for this safety application

### Improper Use

Protection of the personnel and the plant is not ensured if the device is not used according to its intended use.

### 1.3 Symbols Used

This document contains symbols for the identification of warning messages and of informative messages.

#### Warning Messages

You will find warning messages, whenever dangers may arise from your actions. It is mandatory that you observe these warning messages for your personal safety and in order to avoid property damage.

Depending on the risk level, the warning messages are displayed in descending order as follows:



---

#### Danger!

This symbol indicates an imminent danger.

Non-observance will result in personal injury or death.

---



---

#### Warning!

This symbol indicates a possible fault or danger.

Non-observance may cause personal injury or serious property damage.

---



---

#### Caution!

This symbol indicates a possible fault.

Non-observance could interrupt the device and any connected systems and plants, or result in their complete failure.

---

#### Informative Symbols



---

#### Note

This symbol brings important information to your attention.

---



---

#### Action

This symbol indicates a paragraph with instructions. You are prompted to perform an action or a sequence of actions.

## 2 Product Description

### 2.1 Function

#### **KFD2-STC5-1, KFD2-STC5-2**

This signal conditioner provides galvanic isolation between field circuits and control circuits.

The device supplies 2-wire and 3-wire SMART transmitters, and can also be used with 2-wire SMART current sources.

It transfers the analog input signal as an isolated current value.

Digital signals may be superimposed on the input signal on the field side or on the control side and are transferred bi-directionally.

The device provides a sink mode or a source mode output on the control side terminals.

The device has an internal resistor. Use this resistor if the HART communication resistance in the control circuit is too low.

Test sockets for the connection of HART communicators are integrated into the terminals of the device.

#### **KFD2-STC5-1.20**

This signal conditioner provides galvanic isolation between field circuits and control circuits.

The device supplies 2-wire and 3-wire SMART transmitters, and can also be used with 2-wire SMART current sources.

It transfers the analog input signal to the control side as two isolated output signals.

Digital signals may be superimposed on the input signal on the field side or on the control side and are transferred bi-directionally.

The device provides a sink mode or a source mode output on the control side terminals.

The device has an internal resistor. Use this resistor if the HART communication resistance in the control circuit is too low.

Test sockets for the connection of HART communicators are integrated into the terminals of the device.

#### **KFD2-STC5-Ex1(.H), KFD2-STC5-Ex2**

This isolated barrier is used for intrinsic safety applications.

The device supplies 2-wire and 3-wire SMART transmitters, and can also be used with 2-wire SMART current sources.

The device transfers the analog input signal to the non-hazardous area as an isolated current value.

Digital signals may be superimposed on the input signal in the hazardous or non-hazardous area and are transferred bi-directionally.

The device provides a sink mode or a source mode output on the non-hazardous area terminals.

The device has an internal resistor. Use this resistor if the HART communication resistance in the control circuit is too low.

Test sockets for the connection of HART communicators are integrated into the terminals of the device.



### KFD2-STC5-Ex1.20(.H)

This isolated barrier is used for intrinsic safety applications.

The device supplies 2-wire and 3-wire SMART transmitters, and can also be used with 2-wire SMART current sources.

The device transfers the analog input signal to the non-hazardous area as two isolated output signals.

Digital signals may be superimposed on the input signal in the hazardous or non-hazardous area and are transferred bi-directionally.

The device provides a sink mode or a source mode output on the non-hazardous area terminals.

The device has an internal resistor. Use this resistor if the HART communication resistance in the control circuit is too low.

Test sockets for the connection of HART communicators are integrated into the terminals of the device.



**Note**

See corresponding datasheets for further information.

## 2.2

### Interfaces

The device has the following interfaces.

- Safety relevant interfaces:

Input I, output I	KFD2-STC5-1, KFD2-STC5-Ex1, KFD2-STC5-Ex1.H
Input I, output I, output II	KFD2-STC5-1.20, KFD2-STC5-Ex1.20, KFD2-STC5-Ex1.20.H
Input I, input II, output I, output II	KFD2-STC5-2, KFD2-STC5-Ex2

- Non-safety relevant interfaces: none  
The HART communication is not relevant for functional safety.



**Note**

For corresponding connections see datasheet.

## 2.3

### Marking

Pepperl+Fuchs Group Lilienthalstraße 200, 68307 Mannheim, Germany	
Internet: <a href="http://www.pepperl-fuchs.com">www.pepperl-fuchs.com</a>	

KFD2-STC5-1, KFD2-STC5-2, KFD2-STC5-Ex1, KFD2-STC5-Ex1.H, KFD2-STC5-Ex2	Up to SIL 2
KFD2-STC5-1.20, KFD2-STC5-Ex1.20, KFD2-STC5-Ex1.20.H	Up to SIL 3

## 2.4 Standards and Directives for Functional Safety

### Device specific standards and directives

Functional safety	IEC/EN 61508, part 1 – 7, edition 2010: Functional safety of electrical/electronic/programmable electronic safety-related systems (manufacturer)
-------------------	---

### System-specific standards and directives

Functional safety	IEC 61511-1:2016+COR1:2016+A1:2017 EN 61511-1:2017+A1:2017 Functional safety – Safety instrumented systems for the process industry sector (user)
-------------------	---

## 3 Planning

### 3.1 Assumptions

The following assumptions have been made during the FMEDA:

- Failure rate based on the Siemens standard SN 29500.
- Failure rates are constant, wear is not considered.
- External power supply failure rates are not included.
- The safety-related device is considered to be of type **A** device with a hardware fault tolerance of **0**.
- The device will be used under average industrial ambient conditions comparable to the classification **stationary mounted** according to MIL-HDBK-217F.

Alternatively, operating stress conditions typical of an industrial field environment similar to IEC/EN 60654-1 Class C with an average temperature over a long period of time of 40 °C may be assumed. For a higher average temperature of 60 °C, the failure rates must be multiplied by a factor of 2.5 based on experience. A similar factor must be used if frequent temperature fluctuations are expected.

- If you are using the HART function, observe that the HART signal superimposes an analog signal on the signal line. This is negligible for slow acquisition system (typically < 25 acquisition/s). If in doubt, use HART filters at the analog input of the receiving device.
- The application program in the programmable logic controller (PLC) is configured to detect underrange and overrange failures.
- Both channels of the 2-channel device can be used in the same safety function. Observe that both devices use common components and that a simultaneous failure is possible with a common cause factor of 15 %.

#### Applications according to IEC/EN 61508

- To build a SIL safety loop for the defined SIL, it is assumed as an example that this device uses 10 % of the available budget for  $PFD_{avg}/PFH$ .
- Since the safety loop has a hardware fault tolerance of **0** and it is a type **A** device, the SFF must be > 60 % according to table 2 of IEC/EN 61508-2 for a SIL 2 (sub) system.

SIL 3 can be reached if the two outputs of the device are connected to the same control interface and evaluated if the deviation remains below 2 %.

- To build a SIL safety loop for the defined SIL, it is assumed as an example that this device uses 10 % of the available budget for  $PFD_{avg}/PFH$ .
- Since the safety loop has a hardware fault tolerance of **0** and it is a type **A** device, the SFF must be > 90 % according to table 2 of IEC/EN 61508-2 for a SIL 3 (sub) system.

## 3.2 Safety Function and Safe State

### Safety Function

The device transfers analog signals from the input to the output with a deviation of less than 2 %.

Values outside the range of the output signals indicate a fault in the periphery or within the device. Add these failure rates to the dangerous detected failure rates of the connected periphery. The fault ranges of the output signals are shown in the following table.

Device	Input signals	Output signals
KFD2-STC5-1, KFD2-STC5-Ex1, KFD2-STC5-Ex1.H KFD2-STC5-1.2O, KFD2-STC5-Ex1.2O, KFD2-STC5-Ex1.2O.H, KFD2-STC5-2, KFD2-STC5-Ex2	0/4 mA to 20 mA	0/4 mA to 20 mA Fault range: < 3.6 mA or > 21.5 mA

Table 3.1

### Safe State

The safe state depends on the limit value in the respective application.

### Reaction Time

The reaction time for all safety functions is < 100 ms.

**Functional Safety Connection Configuration**

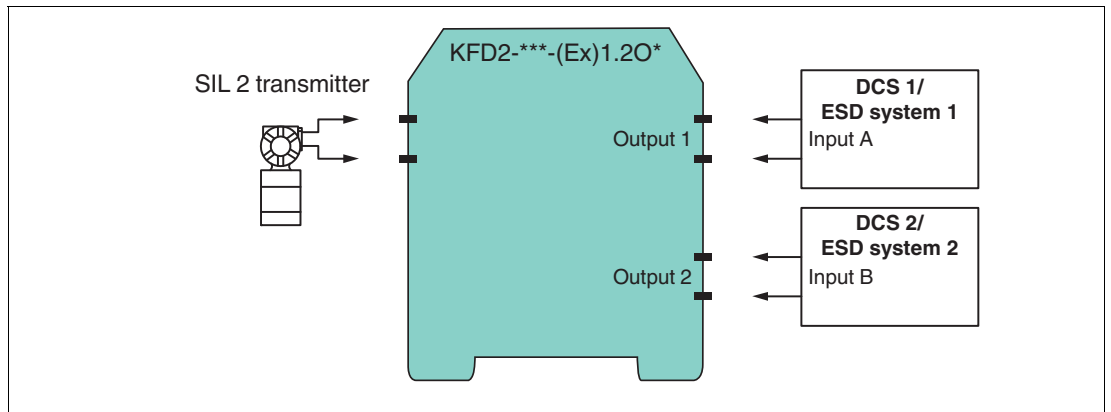

Figure 3.1 SIL 2 application  
This figure refers to the left column of table 3.3.

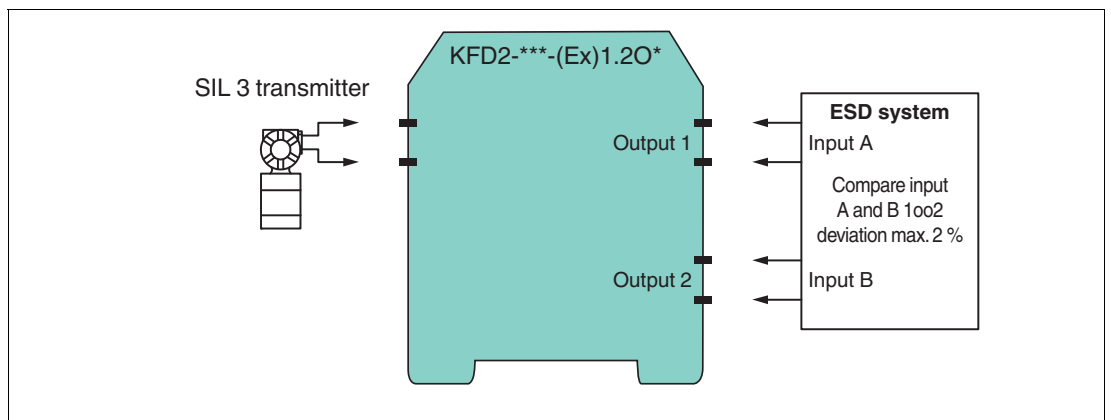

Figure 3.2 SIL 3 application  
This figure refers to the right column of table 3.3.



**Note**

See corresponding datasheets for further information.

### 3.3 Characteristic Safety Values

KFD2-STC5-1, KFD2-STC5-Ex1, KFD2-STC5-Ex1.H, KFD2-STC5-2,  
KFD2-STC5-Ex2

Parameters acc. to IEC 61508	Characteristic values
Assessment type and documentation	Full assessment
Device type	A
Operating mode	Low Demand Mode or High Demand Mode
Safety function	Transfer of analog signals
HFT	0
SIL	2
SC	3
$\lambda_s$	0 FIT
$\lambda_{low}^1$	169 FIT
$\lambda_{du}$	68 FIT
$\lambda_{not\ part}$	72 FIT
$\lambda_{total}$ (safety function)	237 FIT
$\lambda_{total}$	660 FIT
SFF	71 %
PTC	100 %
MTBF <sup>2</sup>	173 years
PFH	$6.78 \times 10^{-8}$ 1/h
PFD <sub>avg</sub> for $T_1 = 1$ year	$2.98 \times 10^{-4}$
PFD <sub>avg</sub> for $T_1 = 2$ years	$5.96 \times 10^{-4}$
PFD <sub>avg</sub> for $T_1 = 5$ years	$1.49 \times 10^{-3}$
Reaction time <sup>3</sup>	< 100 ms

Table 3.2

- <sup>1</sup> **Fail low** failures are considered as dangerous detected failures  $\lambda_{dd}$ .
- <sup>2</sup> acc. to SN29500. This value includes failures which are not part of the safety function/MTTR = 24 h.  
The value is valid for one safety loop only.
- <sup>3</sup> Time between fault detection and fault reaction

KFD2-STC5-1.20, KFD2-STC5-Ex1.20, KFD2-STC5-Ex1.20.H

Parameters acc. to IEC 61508	Characteristic values	
Assessment type and documentation	Full assessment	
Device type	A	
Operating mode	Low Demand Mode or High Demand Mode	
Safety function	Transfer of analog signals	
Input and output function	1 output used in safety function	2 outputs used in safety function
HFT	0	
SIL	2	3
SC	3	
$\lambda_s$	0 FIT	0 FIT
$\lambda_{dd}^1$	177 FIT	327 FIT
$\lambda_{du}$	57 FIT	9.3 FIT
$\lambda_{not\ part}$	74 FIT	117 FIT
$\lambda_{total}$ (safety function)	234 FIT	336 FIT
$\lambda_{total}$	667 FIT	966 FIT
SFF	76 %	97.2 %
PTC	100 %	100 %
MTBF <sup>2</sup>	171 years	115 years
PFH <sub>3</sub>	$5.71 \times 10^{-8}$ 1/h	$9.3 \times 10^{-9}$ 1/h
PFD <sub>avg</sub> for $T_1 = 1$ year <sup>3</sup>	$2.50 \times 10^{-4}$	$4.07 \times 10^{-5}$
PFD <sub>avg</sub> for $T_1 = 2$ years <sup>3</sup>	$4.99 \times 10^{-4}$	$8.15 \times 10^{-5}$
PFD <sub>avg</sub> for $T_1 = 5$ years <sup>3</sup>	$1.25 \times 10^{-3}$	$2.04 \times 10^{-4}$
Reaction time <sup>4</sup>	< 100 ms	

Table 3.3

- 1 **Fail high** and **Fail low** failures are considered as dangerous detected failures  $\lambda_{dd}$ .
- 2 acc. to SN29500. This value includes failures which are not part of the safety function/MTTR = 24 h. The value is valid for one safety loop only.
- 3 The safety characteristic values were calculated considering a common cause factor  $\beta$  of 5 % for the safety relevant output part. For the application with 2 outputs in the safety function, the ESD system needs to detect if the outputs differ by more than 2 %.
- 4 Time between fault detection and fault reaction

The characteristic safety values like PFD, SFF, HFT and  $T_1$  are taken from the SIL report/FMEDA report. Observe that PFD and  $T_1$  are related to each other. The function of the devices has to be checked within the proof test interval ( $T_1$ ).

## 3.4 Useful Lifetime

Although a constant failure rate is assumed by the probabilistic estimation this only applies provided that the useful lifetime of components is not exceeded. Beyond this useful lifetime, the result of the probabilistic estimation is meaningless as the probability of failure significantly increases with time. This useful lifetime is highly dependent on the component itself and its operating conditions – temperature in particular. For example, electrolytic capacitors can be very sensitive to the operating temperature.

This assumption of a constant failure rate is based on the bathtub curve, which shows the typical behavior for electronic components.

Therefore it is obvious that failure calculation is only valid for components that have this constant domain and that the validity of the calculation is limited to the useful lifetime of each component.

It is assumed that early failures are detected to a huge percentage during the installation and therefore the assumption of a constant failure rate during the useful lifetime is valid.

The IEC/EN 61508-2 standard specifies a useful lifetime of 8 to 12 years for devices used within industrial environments. Observe that the useful lifetime can be reduced if the device is exposed to the following conditions:

- highly stressful environmental conditions such as constantly high temperatures
- temperature cycles with high temperature differences
- permanent repeated mechanical stress (vibration)

According to DIN EN 61508-2 standard note N3, appropriate measures taken by the manufacturer and plant operator can extend the useful lifetime.

Our experience has shown that the useful lifetime of a Pepperl+Fuchs product can be higher if the ambient conditions support a long useful lifetime, for example if the ambient temperature is significantly below the maximum ambient temperature.

Please note that the useful lifetime refers to the (constant) failure rate of the device. The effective lifetime can deviate from this.

The estimated useful lifetime is greater than the warranty period prescribed by law or the manufacturer's guarantee period. However, this does not result in an extension of the warranty or guarantee services. Failure to reach the estimated useful lifetime is not a material defect.



## 4 Mounting and Installation



### Mounting and Installing the Device

1. Observe the safety instructions in the instruction manual.
2. Observe the information in the manual.
3. Observe the requirements for the safety loop.
4. Connect the device only to devices that are suitable for this safety application.
5. Check the safety function to ensure the expected output behavior.

### 4.1 Configuration

A configuration of the device is not necessary and not possible.

## 5 Operation



### Danger!

Danger to life from missing safety function

If the safety loop is put out of service, the safety function is no longer guaranteed.

- Do not deactivate the device.
- Do not bypass the safety function.
- Do not repair, modify, or manipulate the device.



### Operating the device

1. Observe the safety instruction in the instruction manual.
2. Observe the information in the manual.
3. Use the device only with devices that are suitable for this safety application.
4. Correct any occurring safe failures within 24 hours. Take measures to maintain the safety function while the device is being repaired.

### 5.1 Proof Test Procedure

This section describes a possible proof test procedure. The user is not obliged to use this proposal. The user may consider different concepts with an individual determination of the respective effectiveness, e. g. concepts according to NA106:2018.

According to IEC/EN 61508-2 a recurring proof test shall be undertaken to reveal potential dangerous failures that are not detected otherwise.

Check the function of the subsystem at periodic intervals depending on the applied  $PFD_{avg}$  in accordance with the characteristic safety values. See chapter 3.2.

It is under the responsibility of the plant operator to define the type of proof test and the interval time period.

#### Conditions

Only use special devices for intrinsically safe circuits for the proof test of the intrinsic safety side of the device .

Intrinsically safe circuits that were operated with non-intrinsically safe circuits may not be used as intrinsically safe circuits afterwards.

- Digital multimeter with an accuracy better than 0.1 %
- Power supply set to nominal voltage of 24 V DC
- Process calibrator with current source and current sink function with an accuracy better than 20  $\mu$ A



### Proof Test Procedure

1. Put out of service the entire safety loop. Protect the application by means of other measures.
2. Prepare a test set-up, see figures below.
3. Test the devices. Verify the current values as given in table below.
4. After the test, reset the device to the original settings.

#### Proof Test for 1- and 2-Channel K-System Devices

Input value (mA)	Output value
	Current source/current sink (mA) for KFD2-STC5-(Ex)*-*(.H)
20.0	20.0 ± 0.4
12.0	12.0 ± 0.4
4.0	4.0 ± 0.4
23.0	23.0 ± 0.4
0	< 0.2

Table 5.1

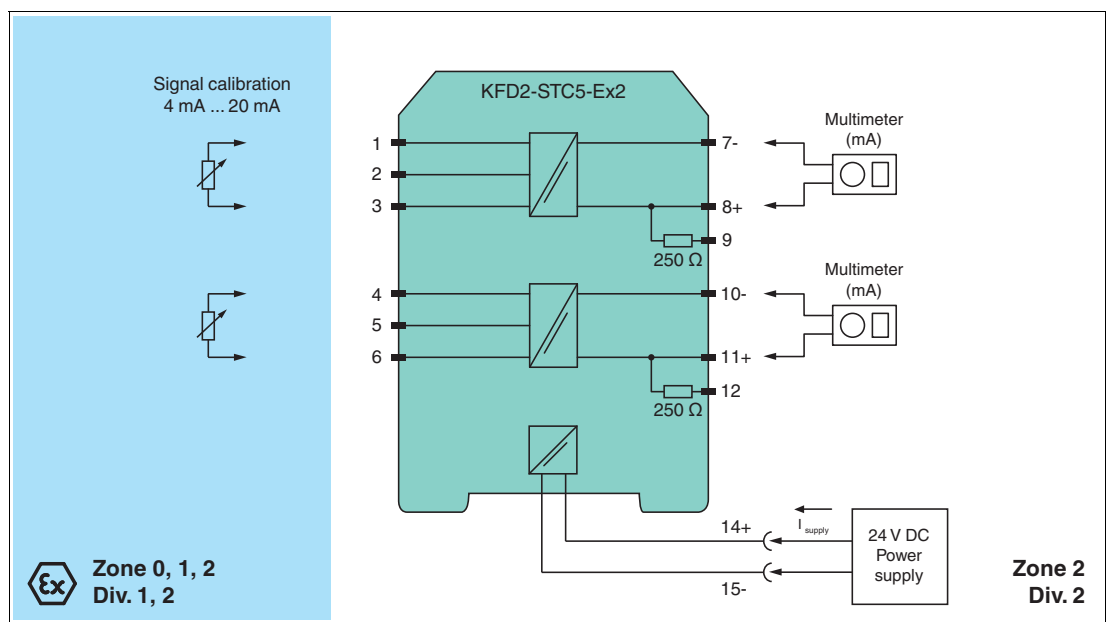

Figure 5.1 Proof test set-up for KFD2-STC5-(Ex)\*-\*(.H)

Usage in Zone 0, 1, 2/Div. 1, 2 only for KFD2-STC5-Ex1, KFD2-STC5-Ex1.H, and KFD2-STC5-Ex2

The KFD2-STC5-1, KFD2-STC5-Ex1, and KFD2-STC5-Ex1.H devices have no second channel.

**Proof Test for K-System Devices with Splitter Function (1.20)**

Input value (mA)	Output value
	Current source/current sink (mA) for KFD2-STC5-(Ex)1.20(.H)
20.0	20.0 ± 0.4
12.0	12.0 ± 0.4
4.0	4.0 ± 0.4
23.0	23.0 ± 0.4
0	< 0.2

Table 5.2

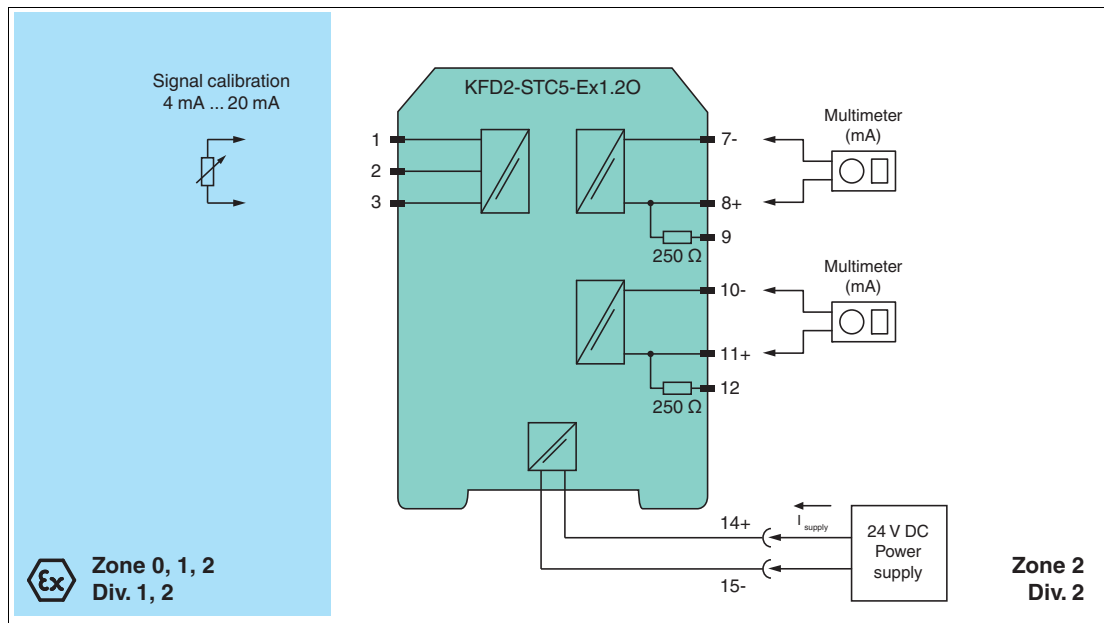

Figure 5.2 Proof test set-up for KFD2-STC5-(Ex)1.20(.H)

Usage in Zone 0, 1, 2/Div. 1, 2 only for KFD2-STC5-Ex1.20 and KFD2-STC5-Ex1.20.H

## 6 Maintenance and Repair



### **Danger!**

Danger to life from missing safety function

Changes to the device or a defect of the device can lead to device malfunction. The function of the device and the safety function is no longer guaranteed.

Do not repair, modify, or manipulate the device.

---



### **Maintaining, Repairing or Replacing the Device**

In case of maintenance, repair or replacement of the device, proceed as follows:

1. Implement appropriate maintenance procedures for regular maintenance of the safety loop.
2. While the device is maintained, repaired or replaced, the safety function does not work. Take appropriate measures to protect personnel and equipment while the safety function is not available. Secure the application against accidental restart.
3. Do not repair a defective device. A defective device must only be repaired by the manufacturer.
4. If there is a defect, always replace the device with an original device.



### **Reporting Device Failure**

If you use the device in a safety loop according to IEC/EN 61508, it is required to inform the device manufacturer about possible systematic failures.

Report all failures in the safety function that are due to functional limitations or a loss of device function – especially in the case of possible dangerous failures.

In these cases, contact your local sales partner or the Pepperl+Fuchs technical sales support (service line).

It is not necessary to report failures in the safety function that are due to external influences or damage.

## 7 List of Abbreviations

<b>ESD</b>	<b>Emergency Shutdown</b>
<b>FIT</b>	<b>Failure In Time</b> in $10^{-9}$ 1/h
<b>FMEDA</b>	<b>Failure Mode, Effects, and Diagnostics Analysis</b>
$\lambda_s$	Probability of safe failure
$\lambda_{dd}$	Probability of dangerous detected failure
$\lambda_{du}$	Probability of dangerous undetected failure
$\lambda_{\text{no effect}}$	Probability of failures of components in the safety loop that have no effect on the safety function.
$\lambda_{\text{not part}}$	Probability of failure of components that are not in the safety loop
$\lambda_{\text{total (safety function)}}$	Probability of failure of components that are in the safety loop
<b>HFT</b>	<b>Hardware Fault Tolerance</b>
<b>MTBF</b>	<b>Mean Time Between Failures</b>
<b>MTTR</b>	<b>Mean Time To Restoration</b>
<b>PCS</b>	<b>Process Control System</b>
<b>PFD<sub>avg</sub></b>	<b>Average Probability of dangerous Failure on Demand</b>
<b>PFH</b>	<b>Average frequency of dangerous failure per hour</b>
<b>PLC</b>	<b>Programmable Logic Controller</b>
<b>PTC</b>	<b>Proof Test Coverage</b>
<b>SC</b>	<b>Systematic Capability</b>
<b>SFF</b>	<b>Safe Failure Fraction</b>
<b>SIF</b>	<b>Safety Instrumented Function</b>
<b>SIL</b>	<b>Safety Integrity Level</b>
<b>SIS</b>	<b>Safety Instrumented System</b>
<b>T<sub>1</sub></b>	<b>Proof Test Interval</b>



# Your automation, our passion.

## Explosion Protection

- Intrinsic Safety Barriers
- Signal Conditioners
- FieldConnex® Fieldbus
- Remote I/O Systems
- Electrical Ex Equipment
- Purge and Pressurization
- Industrial HMI
- Mobile Computing and Communications
- HART Interface Solutions
- Surge Protection
- Wireless Solutions
- Level Measurement

## Industrial Sensors

- Proximity Sensors
- Photoelectric Sensors
- Industrial Vision
- Ultrasonic Sensors
- Rotary Encoders
- Positioning Systems
- Inclination and Acceleration Sensors
- Fieldbus Modules
- AS-Interface
- Identification Systems
- Displays and Signal Processing
- Connectivity

### Pepperl+Fuchs Quality

Download our latest policy here:

[www.pepperl-fuchs.com/quality](http://www.pepperl-fuchs.com/quality)

