



# 2007 REFERENCE & BUYER'S GUIDE

## IDENTIFICATION PRODUCTS



# SPOTLIGHT on RFID

## IDENT Control

RFID interface for connection of up to 4 read/write heads, features include:

- Pushbuttons and graphical display
- Email notification
- Web page configuration
- Completely field mountable

See pages 23-58



## IDENT I System P

RFID single read/write head solution, features include:

- Over 4" of read range
- Read/write head, interface all in one housing
- Bus interfaces including DeviceNet, PROFIBUS

See pages 59-76



## Wide selection of tags under \$10.00

- Mounting on plastic or with spacer
- Up to 256 bytes of read/write data
- Temperature ranges up to 212 ° F(100 ° C)
- High speed reading



## Wide read head selection

- 18 mm dia. to large plate readers 198 mm square
- 5-way rotating head options
- Flat conveyor style readers
- Some heads can be embedded in metal

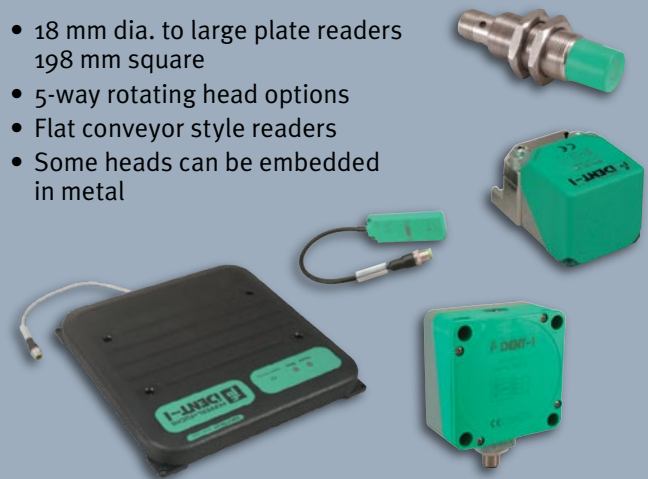

## Conformance Tested

CIP stack identical to make DeviceNet and EtherNet/IP programming interchangeable. No matter which network is installed, your PLC ladder code won't have to change.

- Fully ODVA conformance tested
- Map as few as 8 bytes of data or as many as 100 bytes, depending on application
- Separated mode option allows mapping of all heads individually

**DeviceNet**  
CONFORMANCE TESTED

**EtherNet/IP**  
conformance tested

## Handheld Solutions

- Read/write data to any P+F or ISO standard tag
- Wireless
- Full graphical display with keyboard
- RS-232 / PS2 / USB options included

See pages 77-82



Visit us at [www.am.pepperl-fuchs.com](http://www.am.pepperl-fuchs.com) or call us at 330-486-0001

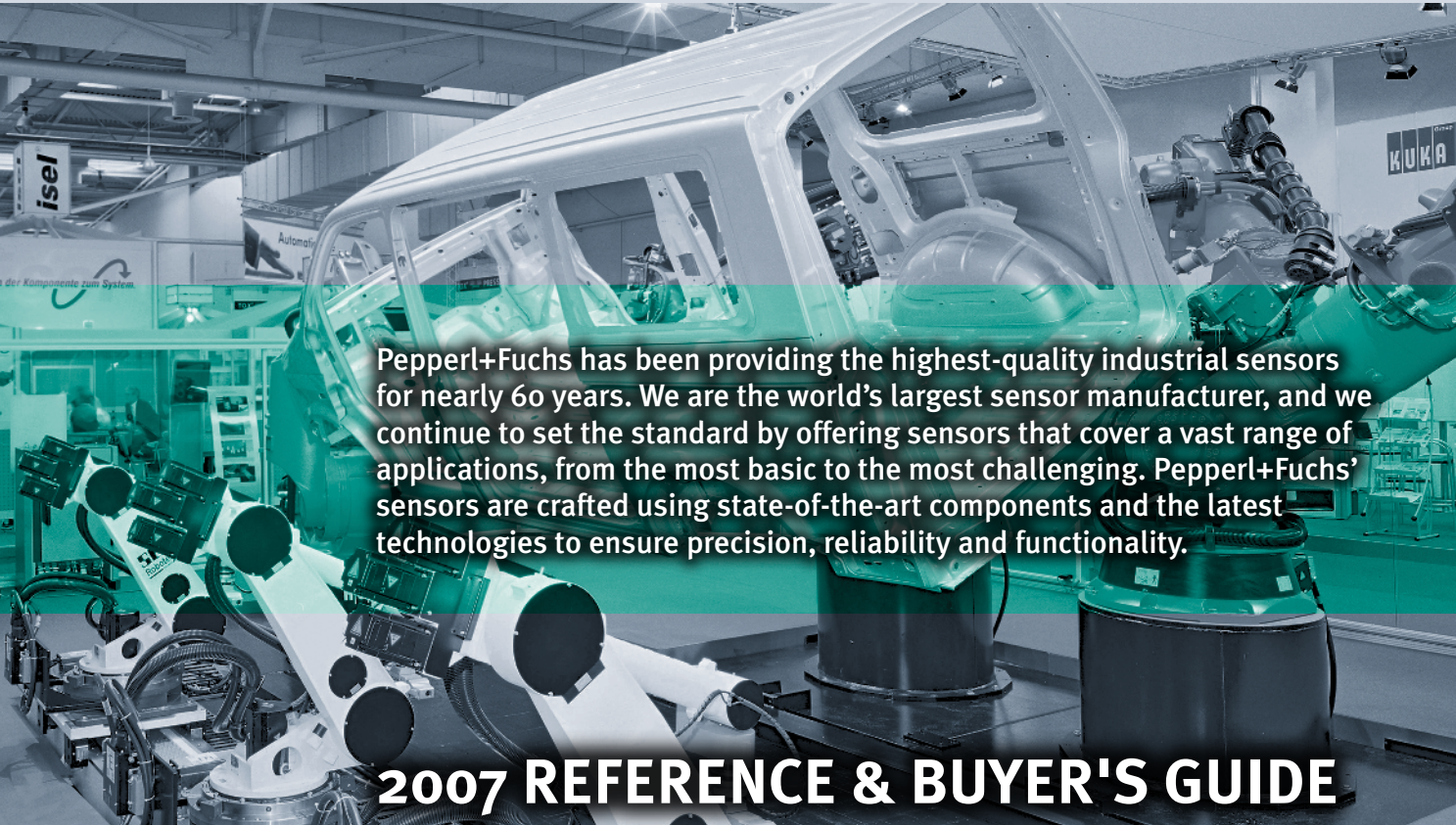

Pepperl+Fuchs has been providing the highest-quality industrial sensors for nearly 60 years. We are the world's largest sensor manufacturer, and we continue to set the standard by offering sensors that cover a vast range of applications, from the most basic to the most challenging. Pepperl+Fuchs' sensors are crafted using state-of-the-art components and the latest technologies to ensure precision, reliability and functionality.

# 2007 REFERENCE & BUYER'S GUIDE

## IDENTIFICATION PRODUCTS

- Introduction..... 2-4**
- RFID Systems ..... 5-96**
- Barcode Imaging Systems.....97-136**
- Appendix ..... 137-142**
- Model Number Index.....143-144**



## Automatic Identification Systems

Automatic Identification Systems allow you to track, monitor, report and manage products, documents, assets, and people more effectively and efficiently as they move between locations. They are used to:

- Automate manufacturing processes
- Provide better inventory control
- Cut down on theft
- Prevent the counterfeiting of products
- Provide easier access to warranty information
- Produce significant savings through supply-chain efficiency improvements

Auto ID systems are flexible enough to touch many different markets and applications, in addition to the manufacturing and inventory environment, Auto ID can track airport cargo, lost golf balls, prescription bottles, wildlife and livestock, and follow patients through the ER.

For nearly 20 years, Pepperl+Fuchs has been a world leader in providing versatile identification systems to hundreds of businesses and organizations. We offer a comprehensive range of RFID systems. There are many frequency ranges available. Each frequency has its advantages and industries where they are often used. P+F supports open standard low frequency (125 and 250 kHz)

as well as ISO based HF systems in the 13.56 MHz range, which currently receive a great deal of attention with respect to pharmaceutical applications based on FDA recommendation, and 2.45 GHz UHF systems.

Another technology used for automatic identification is barcoding. Pepperl+Fuchs manufactures a broad range of 1-D and 2-D barcode readers for a variety of applications, from collection of inventory data using wireless handhelds to high-speed readers capable of capturing rapidly moving packaging in an industrial environment, we have the right barcode imager for your application.

## RFID

Radio Frequency Identification (RFID) is rapidly changing the way business is conducted, and the advantages of RFID are quickly being realized. From automotive plants, to warehouses, to the DOD, and the FDA; the industries incorporating RFID systems include:

- Chemical
- Automotive
- Manufacturing
- Healthcare/Pharmaceutical
- Retail
- Packaging/Labeling
- Transport/Logistics
- Defense/Aerospace

## FDA Clears Way for RFID Tagging

The FDA stated that RFID is an important technology in ensuring the long-term safety and integrity of the U.S. drug supply and has recommended that the pharmaceutical industry should adopt the technology to help combat the proliferation of counterfeit drugs.

Officials believe that the use of RFID tags on drugs will create an electronic “pedigree,” which is a record of the chain of custody of the product as it moves through the supply chain from manufacturer to pharmacy. Most pharmaceutical products will be tagged with electronic product code-compliant RFID tags at the pallet and case level, providing the ability to track and trace the movement of every package of drugs from production to dispensing. The FDA believes RFID will also produce significant savings to the drug industry through supply-chain efficiency improvements.

The significant advantage of all types of RFID systems is the noncontact, non-line-of-sight nature of the technology. Tags can be read through snow, fog, ice, paint, crusted grime, and other visually and environmentally challenging conditions. RFID tags can also be read in challenging circumstances at remarkable speeds, in most cases responding in less than 100 milliseconds. The read/write capability of an active RFID system is also a significant advantage in interactive applications such as work-in-process, maintenance tracking, and error proofing. RFID has become indispensable for a wide range of automated data collection and identification applications that would not be possible otherwise.

## IDENT Control

At the heart of our RFID technology is P+F’s IDENT Control System, our most universal and innovative system. IDENT Control is designed to be easy to use and features a graphical display and configuration keys for easy setup and operation, and a cast aluminum housing for rugged durability and exceptional noise immunity. Short-range and long-range RFID read/write data carriers can operate simultaneously, and can read data up to 250 mm and 4 m away, respectively. Tags can be embedded in steel or surface mounted depending on your application. The system provides an interface to commonly used bus systems, including Ethernet (TCP/IP, Modbus/TCP, and EtherNet/IP), PROFIBUS, RS-232, and DeviceNet.

Battery-operated handheld versions are also available that read or write data in the field without the use of a power cable. These short-range units are perfect for industrial, medical, and logistical applications. They can be standalone applications using only the graphical display, or active applications where data is written and read from a remote database. All features are supported right out of the box, and include a built-in, real-time clock, vibrator, buzzer, and language selection options.

## Barcode Imagers

### One- and two-dimensional codes

Both 1- and 2-D codes are used extensively today. Traditional 1-D barcodes are most often printed on labels and affixed to products. Certain 2-D codes, for instance, Data Matrix, may be “printed” directly on the product by laser, chemical etching, or dot peening. This direct part marking provides a permanent label capable of withstanding aggressive temperature or chemical environments and is extremely wear resistant.

In either case, Pepperl+Fuchs utilizes a camera to acquire the barcode. Once the picture is acquired, it is passed to the decoding algorithm, which identifies the symbology that created the barcode, and then decodes it. Traditional barcode readers use a scanning laser line to read 1-D codes. This is quite efficient but does not provide reliable reading of most matrix 2-D codes. The camera works equally well for both 1- and 2-D symbology.

### 2-D vs. 1-D

One-dimensional barcodes are used in every conceivable industry and application. Each label contains a unique serial number coded in black and white bars that are keys into a database containing detailed information (much like a license plate on an automobile). Yet many end users want to code more information. They want the barcode to be a portable database rather than just a reference to a database entry.

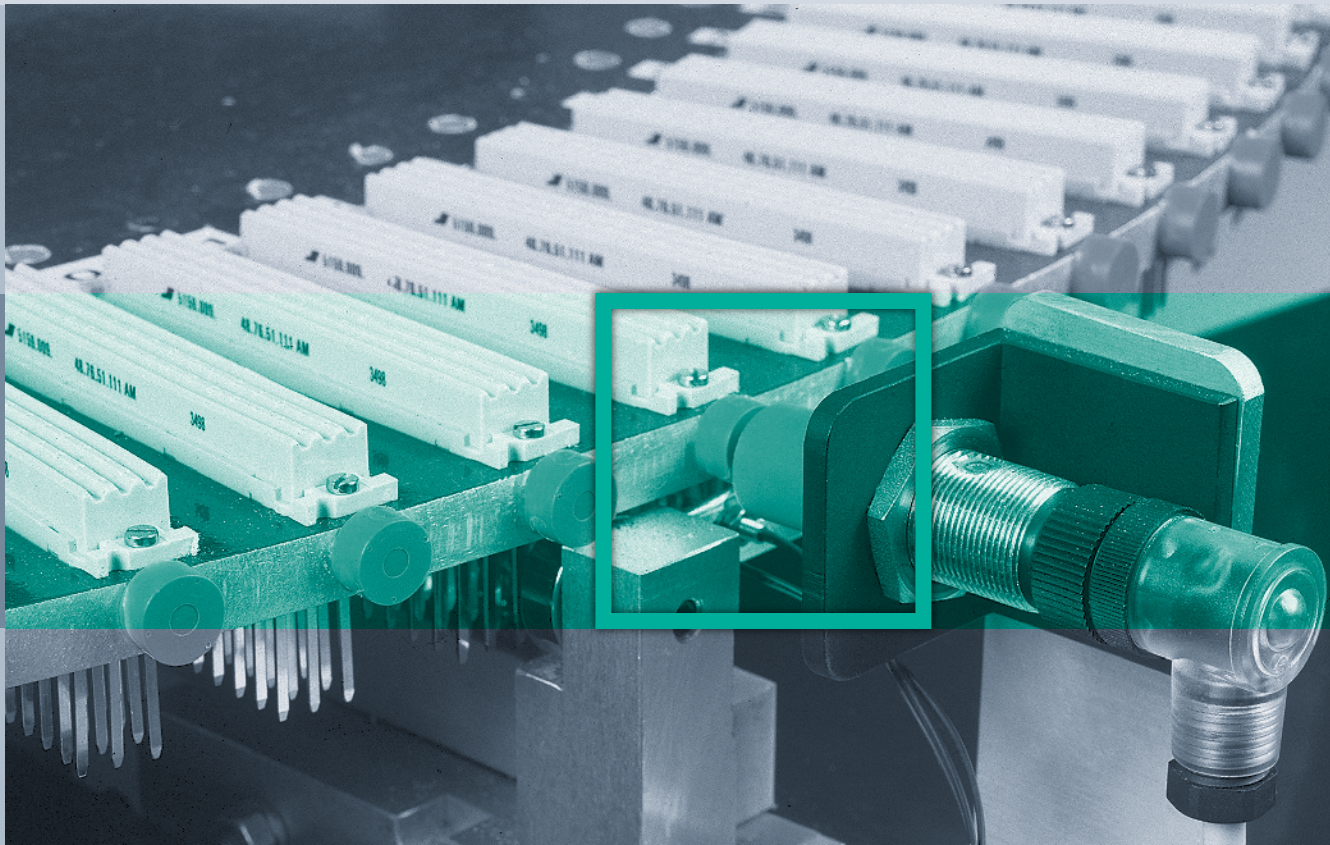

When it comes to capacity, 2-D barcodes, such as Data Matrix have an enormous edge over the traditional linear barcode symbologies (like UPC and Code 39). While traditional barcode symbologies can only encode 10 to 20 characters of information, 2-D symbologies encode several thousand characters of machine-readable data. In effect, a portable database can travel with your product. Because the data content can be large, several traditional barcodes plus text can be included in one symbol. The beauty of this is that the cost of the labels is negligible. If you're already printing a label on your boxes, adding another printed symbol next to the product code won't add much to the cost.

Data Matrix is a 2-D matrix code designed to pack a lot of information in a very small space. The code has several other interesting features. Since the information is encoded by absolute dot position rather than relative dot position, it is not as susceptible to printing defects, as is traditional bar code. The coding scheme has a high level of redundancy with the data "scattered" throughout the symbol. This allows the symbol to be read correctly even if part of it is missing or obscured.

Data Matrix barcode imagers are useful when RFID is too expensive and simple barcoding is too rudimentary. With built-in Reed Solomon error correction, mis-reads are negligible; and barcode imagers are unaffected by metallic materials. In fact, the codes can be peened onto

the surface of a metal object mechanically or etched onto many surfaces with a laser. Laser etching uses short blasts of laser light to ablate the Data Matrix code onto a surface.

### Choosing The Correct Technology

Developments in RFID technology continue to yield larger memory capacities, wider reading ranges, and faster processing; and certainly RFID is gaining popularity with other traditional Identification Technologies (e.g., barcode). Each technology has advantages that are best suited to the application at hand. We can look at the relative importance and costs of several factors in choosing between RFID and barcode technologies:

	Barcode Systems	RFID Systems
<b>Integration Effort</b>	Low	Moderate
<b>Ease of Mounting/ Installation</b>	Easy to Medium	Easy to Medium
<b>Implementation Costs</b>	Low	Medium to High
<b>Media Associated Costs</b>	Low	Medium to High
<b>On-the-fly Update</b>	No, Reprint	Yes
<b>Line of Sight</b>	Yes	No
<b>Data Capacity</b>	Small to Medium	Small to Large
<b>Noise Immunity</b>	Very High	Depends on Environment
<b>Privacy/Encryption, Tamperproof</b>	No (Possible w/2D)	Yes
<b>Suitable for Open Systems</b>	Very	Somewhat

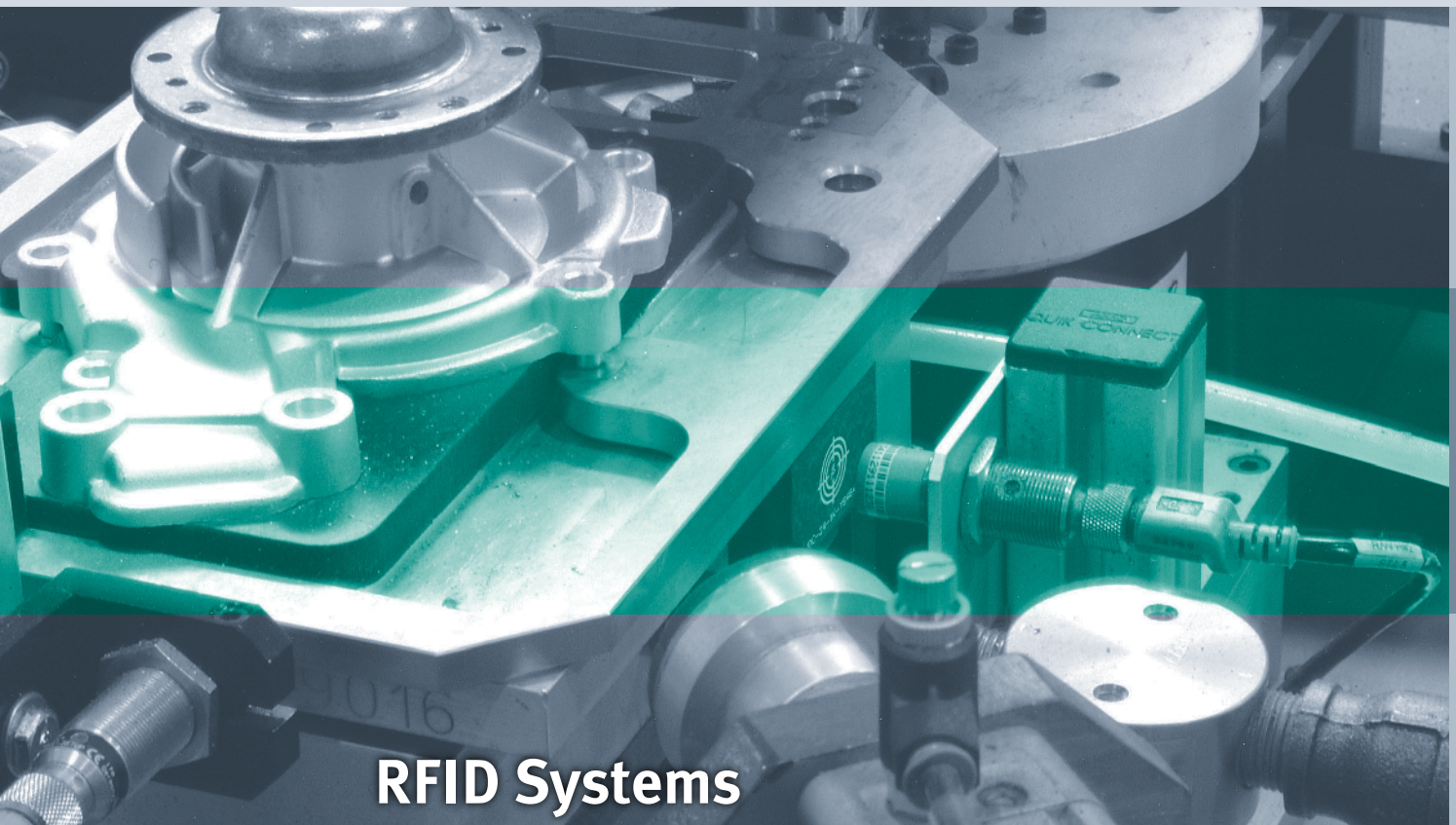



## RFID Systems

<b>RFID Systems Selection Guide .....</b>	<b>6-14</b>
<b>Markets and Applications.....</b>	<b>15-16</b>
<b>Fundamentals of RFID .....</b>	<b>17-22</b>
<b>IDENT Control .....</b>	<b>23-58</b>
<b>IDENT I System P.....</b>	<b>59-76</b>
<b>Handheld Solutions.....</b>	<b>77-82</b>
<b>RFID Accessories .....</b>	<b>83-96</b>

## Pepperl+Fuchs IDENT Control

IDENT Control is truly an innovative unified RFID solution, offering outstanding functionality and features needed to solve demanding applications. IDENT Control is a full product family that includes (1) IDENT Control interfaces, (2) a large selection of read/write heads and (3) data tags for just about any application and environment.

## Interfaces

	 <b>ETHERNET</b>	 <b>PROFIBUS</b>	<i>DeviceNet.</i>	<b>RS-232</b>
<b>See Page</b>	29	29	29	29
<b>Highlights</b>	<ul style="list-style-type: none"> <li>Email errors and tag data automatically</li> <li>Web page configuration and diagnostics</li> </ul>	<ul style="list-style-type: none"> <li>Enclosure mount and field mount versions available</li> <li>Baud rates to 12 Mbps supported</li> </ul>	<ul style="list-style-type: none"> <li>Variable produced and consumed sizes</li> <li>Automatic parameterization</li> </ul>	<ul style="list-style-type: none"> <li>Read/write over 1000 bytes to tag at one time</li> <li>Completely field mountable</li> </ul>
<b>Read Heads/Trigger Sensors</b>	4	4	4	4
<b>Communications</b> <i>(protocol or communication method)</i>	Modbus/TCP, EtherNet/IP, PROFINET, PCCC or Standard TCP/IP	PROFIBUS DP	Polled, Change of State, Cyclic, Explicit	RS-232 Standard
<b>Addressable</b>	IP Address, Subnet Mask, Gateway	0-126	0-63	N/A
<b>Baud Rate</b>	10/100 Mbps	Up to 12 Mbps	125, 250, 500 Kbps	Up to 38.4 Kbps
<b>IP Rating</b>	IP67*	IP40 or IP67	IP67	IP67
<b>Bus Connection</b>	Amphenol/RJ45	DB9 female or 5-pin, B-coded, M12 Micro	5-pin 7/8" Mini	M12 Micro
<b>Model</b>	<b>IC-KP-B12-V45</b>	<b>IC-KP-B6-SUBD</b> <b>IC-KP-B6-V15B</b>	<b>IC-KP-B7-V95</b>	<b>IC-KP-R2-V1</b>

\* When used with appropriate RJ45 cable cover.

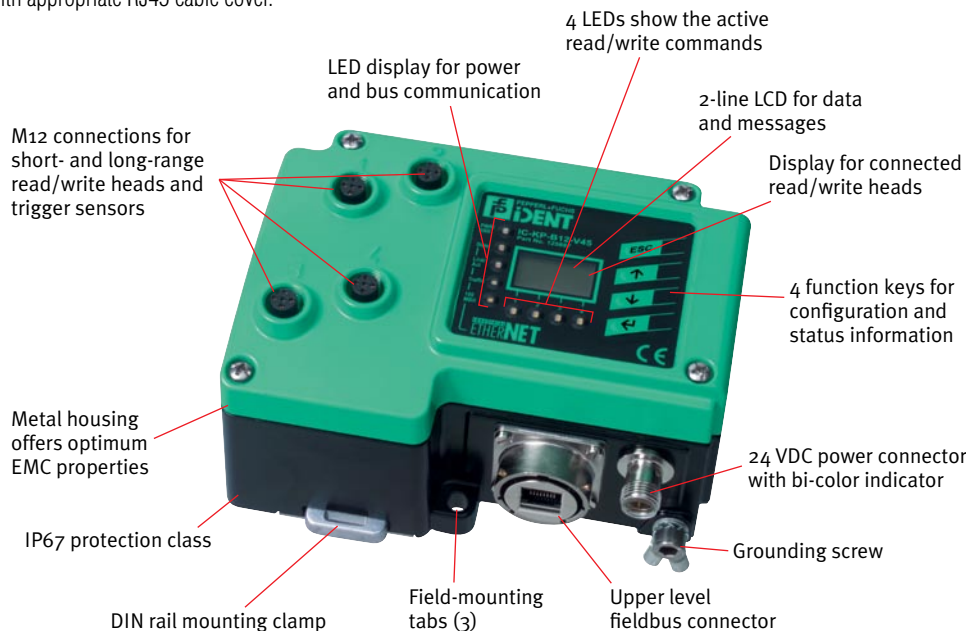











## Series Q

This high frequency (HF) system is specifically designed to read tags supporting ISO 15693. This industry standard allows P+F, as well as many other manufacturers, to provide industrial, as well as low-cost adhesive tags for many markets. These 13.56 MHz tags are recognized for their high data access speeds. High-speed production lines and read-on-the-fly type applications may be perfect applications for Series Q.

## Read/Write Heads

	 <b>18 mm</b>	 <b>Flat Pack</b>	 <b>F100</b>
<b>See Page</b>	33	33	33
<b>Highlights</b>	<ul style="list-style-type: none"> <li>• Smallest read head in short housing</li> </ul>	<ul style="list-style-type: none"> <li>• Embeddable in metal</li> </ul>	<ul style="list-style-type: none"> <li>• Adjustable sensitivity</li> </ul>
<b>Sensing Face Size</b>	18 mm dia.	80 mm x 80 mm	298 mm x 298 mm
<b>Read Range (50 mm Tag)</b>	58 mm	102 mm	250 mm
<b>Write Range (50 mm Tag)</b>	58 mm	102 mm	250 mm
<b>Frequency</b>	13.56 MHz		
<b>Read Speed, Read Only Code</b>	20.5 ms		
<b>Read Speed, 4 Bytes</b>	14.2 ms		
<b>Write Speed, 4 Bytes</b>	IQC21 29.6 ms, IQC22 22.6 ms		
<b>Model</b>	<b>IQH-18GM-V1</b>	<b>IQH-FP-V1</b>	<b>IQH-F100-V1</b>

## Tags

	 <b>30P</b>	 <b>50P</b>	 <b>58</b>	 <b>C5</b>	 <b>C1</b>	 <b>C4</b>
<b>See Page</b>	34	34	34	35	35	35
<b>Highlights</b>	<ul style="list-style-type: none"> <li>• Thin tag with center mounting hole</li> </ul>	<ul style="list-style-type: none"> <li>• Rigid tag with center mounting hole</li> </ul>	<ul style="list-style-type: none"> <li>• Impact resistant housing with built in spacer</li> </ul>	<ul style="list-style-type: none"> <li>• Small credit card style</li> </ul>	<ul style="list-style-type: none"> <li>• ISO credit card style</li> </ul>	<ul style="list-style-type: none"> <li>• Large plate tag with easy mount tabs</li> </ul>
<b>Dimension</b>	30 mm dia.	50 mm dia.	58 mm dia.	30 mm x 42.2 mm	54 mm x 85.6 mm	64.5 mm x 96 mm
<b>Temperature (High)</b>	212°F (100°C)	185°F (85°C)	185°F (85°C)	185°F (85°C)	122°F (50°C)	185°F (85°C)
<b>Mounting</b>	in/on plastic		on metal	in/on plastic		
<b>Model</b>	<i>112 byte read/write</i> <b>IQC21-30P</b>	<b>IQC21-50P</b>	<b>IQC21-58</b>	<b>IQC22-C5</b>	<b>IQC22-C1</b>	<b>IQC22-C4</b>
	<i>256 byte read/write</i>					

## Series P

This low frequency (LF) system is specifically designed for factory automation applications. Due to their low frequency, tags and read heads can be placed in close proximity to metal pallets and machine tools. Tags can be embedded flush in any metal and still maintain good read/write performance. Also available are special tags for high temperatures exceeding 200°C and tags for washdown environments with IP69K protection ratings.

## Read/Write Heads



	18 mm	30 mm	F61	Rhino™	Flat Pack	F15
<b>See Page</b>	39	39	39	39	39	39
<b>Highlights</b>	<ul style="list-style-type: none"> <li>• Smallest read head in short housing</li> </ul>	<ul style="list-style-type: none"> <li>• Short barrel</li> </ul>	<ul style="list-style-type: none"> <li>• Conveyor style only 12 mm thick</li> </ul>	<ul style="list-style-type: none"> <li>• Compact housing with 5-way rotating head</li> </ul>	<ul style="list-style-type: none"> <li>• Embeddable in metal</li> </ul>	<ul style="list-style-type: none"> <li>• Heavy duty with long range</li> </ul>
<b>Sensing Face Size</b>	18 mm dia.	30 mm dia.	28 mm x 28 mm	40 mm x 40 mm	80 mm x 80 mm	140 mm x 140 mm
<b>Read Range (50 mm Tag)</b>	50 mm	69 mm	78 mm	77 mm	101 mm	111 mm
<b>Write Range (50 mm Tag)</b>	41 mm	43 mm	64 mm	65 mm	84 mm	105 mm
<b>Frequency</b>	125 kHz					
<b>Read Speed, Read Only Code</b>	40 ms					
<b>Read Speed, 4 Bytes</b>	130 ms					
<b>Write Speed, 4 Bytes</b>	200 ms					
<b>Model</b>	IPH-18GM-V1	IPH-30GM-V1	IPH-F61-V1	IPH-L2-V1	IPH-FP-V1	IPH-F15-V1

## Tags

for mounting on plastic or w/spacer



	12	16	20CD	20W	20K1
<b>See Page</b>	40, 42	40	40	40, 43	43
<b>Highlights</b>	<ul style="list-style-type: none"> <li>• Extended temperature epoxy housing</li> </ul>	<ul style="list-style-type: none"> <li>• High-temperature epoxy housing</li> </ul>	<ul style="list-style-type: none"> <li>• Ultra-thin clear disk</li> </ul>	<ul style="list-style-type: none"> <li>• Thin wafer style</li> </ul>	<ul style="list-style-type: none"> <li>• Key ring style</li> </ul>
<b>Dimensions</b>	12 mm dia.	16 mm dia.	20 mm dia.	20 mm dia.	31 mm x 41 mm
<b>Temperature (High)</b>	266°F (130°C)	302°F (150°C)	140°F (60°C)	194°F (90°C)	194°F (90°C)
<b>Model</b>	<i>5 byte read only</i> <b>IPC02-12</b>	<b>IPC02-16</b>	<b>IPC02-20CD</b>	<b>IPC02-20W</b>	
	<i>5 byte WORM</i> <b>IPC11-12</b>				
	<i>116 byte read/write</i>			<b>IPC03-20W</b>	<b>IPC03-20K1</b>

# Tags

for mounting on metal



**CT**



**54**



**58**

<b>See Page</b>	46	46	46
<b>Highlights</b>	<ul style="list-style-type: none"> <li>• Mounting on Bosch or similar pallets</li> </ul>	<ul style="list-style-type: none"> <li>• Extended temperature ratings</li> </ul>	<ul style="list-style-type: none"> <li>• Large capacity and unlimited write options</li> </ul>
<b>Dimensions</b>	50.8 mm x 33 mm	54 mm dia.	58 mm dia.
<b>Temperature (High)</b>	194°F (90°C)	248°F (120°C)	185°F (85°C)
<b>Model</b>	<i>116 byte read/write</i> <b>IPC03-20CT</b>	<b>IPC03-54-T8</b>	<b>IPC03-58</b>
	<i>8192 byte read/write</i>		<b>IPC12-58-64K</b>

# Tags

for mounting in metal



**12.4**



**16GK**



**24**



**30GK**

<b>See Page</b>	45	45	45	45
<b>Highlights</b>	<ul style="list-style-type: none"> <li>• Cup design good for wet environments</li> </ul>	<ul style="list-style-type: none"> <li>• Threaded tag for easy removal</li> </ul>	<ul style="list-style-type: none"> <li>• Press fit ribbed housing design</li> </ul>	<ul style="list-style-type: none"> <li>• Threaded tag for easy removal</li> </ul>
<b>Dimensions</b>	12.4 mm dia.	M16	24 mm dia.	M30
<b>Temperature (high)</b>	185°F (85°C)	185°F (85°C)	185°F (85°C)	185°F (85°C)
<b>Models</b>	<i>116 byte read/write</i> <b>IPC03-12.4</b>	<b>IPC03-16GK</b>	<b>IPC03-24</b>	<b>IPC03-30GK</b>



**30W**



**50W/50P**



**68**



**C1**



**100**

41, 42, 43	41, 42, 44	41	41, 44	44
<ul style="list-style-type: none"> <li>• Thin wafer style with mounting hole</li> </ul>	<ul style="list-style-type: none"> <li>• Thin wafer style with mounting hole</li> </ul>	<ul style="list-style-type: none"> <li>• High temperature tag</li> </ul>	<ul style="list-style-type: none"> <li>• ISO credit card style</li> </ul>	<ul style="list-style-type: none"> <li>• Largest tag offered, epoxy disk</li> </ul>
30 mm dia.	50 mm dia.	68 mm dia.	54 mm x 85.6 mm	100 mm dia.
194°F (90°C)	194°F (90°C)	392°F (200°C)	158°F (70°C)	194°F (90°C)
<b>IPC02-30W</b>	<b>IPC02-50W</b>	<b>IPC02-68-T7</b>	<b>IPC02-C1</b>	
<b>IPC11-30</b>	<b>IPC11-50</b>			
<b>IPC03-30W</b>	<b>IPC03-50P</b>		<b>IPC03-C1</b>	<b>IPC03-100</b>

## Series S

Series S is often used when there is a need for speed. Along with the standard read/write capabilities of the system, a special 24-bit read/write can be used. This special code is read in only 5 ms. Series S is the fastest short-range system we offer. The tags are the same as those used in our IDENT I System V. Line expansions are simple using IDENT Control, old and new systems are intermixed seamlessly.

## Read/Write Heads



**18 mm**



**F61**



**Flat Pack**

See Page	49	49	49
<b>Highlights</b>	<ul style="list-style-type: none"> <li>• Smallest read head in short housing</li> </ul>	<ul style="list-style-type: none"> <li>• Conveyor style only 12 mm thick</li> </ul>	<ul style="list-style-type: none"> <li>• Embeddable in metal</li> </ul>
<b>Sensing Face Size</b>	18 mm dia.	28 mm x 76 mm	80 mm x 80 mm
<b>Read Range (50 mm Tag)</b>	40 mm	42 mm	95 mm
<b>Write Range (50 mm Tag)</b>	39 mm	42 mm	80 mm
<b>Frequency</b>	250 kHz		
<b>Read Speed, Read Only Code</b>	13 ms, 5 ms for high speed code		
<b>Read Speed, 4 Bytes</b>	13 ms		
<b>Write Speed, 4 Bytes</b>	100 ms		
<b>Model</b>	<b>ISH-18GM-V1</b>	<b>ISH-F61</b>	<b>ISH-FP-V1</b>

## Tags

for mounting in metal



**8**



**10**



**12**



**12.4**



**15**

See Page	50, 52	52	50, 52	50	52
<b>Highlights</b>	<ul style="list-style-type: none"> <li>• Smallest embeddable tag</li> </ul>	<ul style="list-style-type: none"> <li>• Machine tool standard</li> </ul>	<ul style="list-style-type: none"> <li>• Epoxy housing</li> </ul>	<ul style="list-style-type: none"> <li>• Cup housing design for superior protection from liquids</li> </ul>	<ul style="list-style-type: none"> <li>• Cup housing design for superior protection from liquids</li> </ul>
<b>Dimensions</b>	8 mm dia.	10 mm dia.	12 mm dia.	12.4 mm dia.	15 mm dia.
<b>Temperature (high)</b>	185°F (85°C)	185°F (85°C)	185°F (85°C)	302°F (150°C)	185°F (85°C)
<b>Model</b>	<b>ICC-8A</b>	<b>IDC-10-1K</b>	<b>IDC-12-1K</b>	<b>ICC-12A-T1</b>	<b>IDC-15-1K</b>
<i>7 byte read only</i>					
<i>128 byte read/write</i>	<b>IDC-8-1K</b>	<b>IDC-10-1K</b>	<b>IDC-12-1K</b>		<b>IDC-15-1K</b>

## Tags

for mounting on plastic or w/spacer



**50**



**50F**

<b>See Page</b>	51, 54	54
<b>Highlights</b>	<ul style="list-style-type: none"> <li>• Easy mount with single mounting screw</li> </ul>	<ul style="list-style-type: none"> <li>• Flange mount with 5 mounting holes</li> </ul>
<b>Dimensions</b>	50 mm dia.	50 mm x 50 mm
<b>Temperature (High)</b>	185°F (85°C)	185°F (85°C)
<b>Model</b>	<i>7 byte read only</i> <b>ICC-50A</b>	
	<i>128 byte read/write</i> <b>IDC-50-1K</b>	<b>IDC-50F-1K</b>

## Tags

for mounting on metal



**30F**



**58**



**CT**

<b>See Page</b>	54	54	53
<b>Highlights</b>	<ul style="list-style-type: none"> <li>• Mounting flange</li> </ul>	<ul style="list-style-type: none"> <li>• Industrial housing</li> </ul>	<ul style="list-style-type: none"> <li>• Pallet mount</li> </ul>
<b>Dimensions</b>	12.4 mm dia.	M16	50.8 mm x 33 mm
<b>Temperature (High)</b>	185°F (85°C)	185°F (85°C)	185°F (85°C)
<b>Model</b>	<i>128 byte read/write</i> <b>IDC-30F-1K</b>	<b>IDC-58-1K</b>	<b>IDC-24-1K-Y94646</b>



**16GK**

53



**24**

53



**30GK**

51, 53

- Threaded tag for easy installation and removal, tool available
- Press fit ribbed housing design
- High temperature versions available with protective caps

M16

24 mm dia.

M30

185°F (85°C)

185°F (85°C)

302°F (150°C) or  
185°F (85°C)

**ICC-30GKA-T1**  
**ICC-30GKA-T3**

**IDC-16GK-1K**

**IDC-24-1K**

**IDC-30GK-1K**

## Series MV

Series MV is P+F's highest performance system. This active system uses a tag with a long-life battery that can be replaced quickly and inexpensively. The long-range antennas will exceed 2 m of read/write range, providing very fast passing speeds of over 500 miles/hour. The readers can transmit 64 Kb of data to and from the tag at each station.

## Read/Write Heads



**F15**

<b>See Page</b>	57
<b>Highlights</b>	<ul style="list-style-type: none"> <li>• Stainless steel mounting flange</li> </ul>
<b>Sensing Face Size</b>	140 mm x 140 mm
<b>Read Range</b>	0-0.5 m, max 1.5 m   0.2-2 m, max 4 m
<b>Write Range</b>	0-0.5 m, max 1.5 m   0.2-2 m, max 4 m
<b>Frequency</b>	2.45 GHz
<b>Read Speed, Read Only Code</b>	8 ms
<b>Read Speed, 4 Bytes</b>	17 ms
<b>Write Speed, 4 Bytes</b>	29 ms
<b>Model</b>	<b>MVH500-F15-V1</b>   <b>MVH2000-F15-V1</b>

## Tags

for mounting in/on any material



**60B**

<b>See Page</b>	57
<b>Highlights</b>	<ul style="list-style-type: none"> <li>• Replaceable battery</li> </ul>
<b>Dimensions</b>	90 mm x 60 mm
<b>Temperature (High)</b>	158°F (70°C)
<b>Model</b>	<i>7552 byte read/write</i> <b>MVC-60B-64K</b>

## System P

IDENT I System P was designed as a single read head solution with many industrial bus connection options. This low frequency RFID system is good for applications including AGV positioning, roller coaster car maintenance tracking, meat tracking, automotive paint lines, assembly line error proofing, and crane positioning.

## Read/Write Head



<b>See Page</b>	61
<b>Highlights</b>	<ul style="list-style-type: none"> <li>Read head and controller in one housing</li> </ul>
<b>Sensing Face Size</b>	80 mm dia.
<b>Read Range (50 mm Tag)</b>	101 mm
<b>Write Range (50 mm Tag)</b>	93 mm
<b>Frequency</b>	125 kHz
<b>Read Speed, Read Only Code</b>	40 ms
<b>Read Speed, 4 Bytes</b>	130 ms
<b>Write Speed, 4 Bytes</b>	200 ms
<b>Model</b>	<b>IPT1-FP</b>

## Bases



	RS-232/RS-485	RS-485 Multidrop	
<b>See Page</b>	61	61	
<b>Highlights</b>	<ul style="list-style-type: none"> <li>RS-232 or RS-485 with one conduit entrance</li> </ul>	<ul style="list-style-type: none"> <li>Up to 30 read heads on one RS-485 network</li> </ul>	
<b>Read Heads</b>	1	1	
<b>Communications</b>	RS-232, RS-485	RS-485	
<b>Addressable</b>	Point-to-point	Point-to-point, 1-31	
<b>Baud Rate</b>	Up to 38.4 kbps		
<b>IP Rating</b>	IP67 (with read head attached)		
<b>Bus Connection</b>	Conduit/cordgrip/quick disconnect		
<b>Model</b>	<i>Standard</i>	<b>U-P4-RX</b>	<b>U-P4-R4</b>
	<i>Metric Thread (M20)</i>	<b>U-P3-RX</b>	<b>U-P3-R4</b>
	<i>Stainless Steel</i>	<b>U-P3V4A-RX</b>	<b>U-P3V4A-R4</b>
	<i>Quick Disconnect</i>		<b>U-P4-R4-V15</b>

## Tags

for mounting on plastic or w/spacer



	16	20CD	20W	20K1	30W	50W/50P
<b>See Page</b>	71	71	71, 74	74	72, 73, 74	72, 73, 75
<b>Highlights</b>	<ul style="list-style-type: none"> <li>High-temperature epoxy housing</li> </ul>	<ul style="list-style-type: none"> <li>Ultra-thin clear disk</li> </ul>	<ul style="list-style-type: none"> <li>Thin wafer style</li> </ul>	<ul style="list-style-type: none"> <li>Key ring style</li> </ul>	<ul style="list-style-type: none"> <li>Thin wafer style with mounting hole</li> </ul>	<ul style="list-style-type: none"> <li>Thin wafer style with mounting hole</li> </ul>
<b>Dimensions</b>	16 mm dia.	20 mm dia.	20 mm dia	31 mm x 41 mm	30 mm dia.	50 mm dia.
<b>Temperature (High)</b>	302°F (150°C)	140°F (60°C)	194°F (90°C)	194°F (90°C)	194°F (90°C)	194°F (90°C)
<b>Model</b>	<i>5 byte read only</i>	<b>IPC02-16</b>	<b>IPC02-20W</b>		<b>IPC02-30W</b>	<b>IPC02-50W</b>
	<i>5 byte WORM</i>				<b>IPC11-30</b>	<b>IPC11-50</b>
	<i>116 byte read/write</i>			<b>IPC03-20W</b>	<b>IPC03-20K1</b>	<b>IPC03-30W</b>



### PROFIBUS

61

- Standard or stainless steel options

1

PROFIBUS DP

0-126

Up to 12 Mbps

IP67 (with read head attached)

Cordgrip/quick disconnect

**U-P6-B6**

**U-P6V4A-B6**

**U-P6-B6-V15B**



### INTERBUS

61

- Baud rate selector switch and quick disconnect options

1

INTERBUS

512 addresses

500 kbps, 2 Mbps

**U-P6-B5**

**U-P6-B5-V**

## Network Adapters



### Ethernet

67

#### Highlights

- Web page configuration, debug and mirror ports included

#### Read Heads/Bases

4, 8, or 16

#### Communications

Modbus/TCP, TCP/IP with PFT mode

#### Addressable

IP address, Subnet Mask, Gateway

#### Baud Rate

10/100 Mbps

#### IP Rating

IP20

#### Bus Connection

RJ45

#### Model

**RTS 4P DB9**  
**RTS 8P DB9**  
**RTS 16P**



### DeviceNet

67

- Network adapter and read heads all powered off DeviceNet

2

Polled

125, 250, 500 kbps

IP67

5-pin M12 male 1 m pigtail

**IPG-G4-B7-V15**



**68**

72

- High temperature tag

68 mm dia.

392°F (200°C)

**IPC02-68-T7**



**C1**

72, 75

- ISO credit card style

54 mm x 85.6 mm

158°F (70°C)

**IPC02-C1**

**IPC03-C1**



**100**

75

- Largest tag offered, epoxy disk

100 mm dia.

194°F (90°C)

**IPC03-100**

**IPC03-100**

## Tags for mounting on metal



**CT**

76

#### Highlights

- Mounting on Bosch or similar pallets

#### Dimensions

50.8 mm x 33 mm

#### Temperature (High)

194°F (90°C)

#### Model

116 byte read/write

8192 byte read/write

**IPC03-20CT**



**54**

76

- Extended temperature ratings

54 mm dia.

248°F (120°C)

**IPC03-54-T8**



**58**

76

- Large capacity and unlimited write options

58 mm dia.

185°F (85°C)

**IPC03-58**

**IPC12-58-64K**

## Handheld Programmiers

These handheld programmers are designed to work with all of the low- and high-frequency tags that P+F offers. They can also be used for third-party tags that adhere to ISO standard 15693 or that use tags containing the supported chips. Handhelds are useful for a variety of tasks including: initial tag programming, sequence verification before shipping, inventory control, and at offline programming stations. They also enable you to read/write tag data to databases and take database data and write it to the tags.

## Handhelds



<b>See Pages</b>	79	79	79
<b>Highlights</b>	<ul style="list-style-type: none"> <li>Reads all Series Q tags and ISO 15693 standard tags</li> </ul>	<ul style="list-style-type: none"> <li>Reads all Series P and IDENT I System P tags</li> </ul>	<ul style="list-style-type: none"> <li>Reads all Series S and IDENT I System V tags</li> </ul>
<b>P+F Tags Read</b>	IQC...	IPC...	IDC... and ICC...
<b>ISO Standards</b>	ISO 15693		
<b>Chips Supported</b>	Tag-it HF-I, I-Code SLI, SRF55V10P, SRF55V02P, + all read only codes	EM4450, EM4102, Q5, AT5557	P+F specific chips
<b>Communication Options</b>	Wireless Bluetooth, RS-232, PS/2, USB		
<b>Programming Options</b>	Demo program included. Javascript programming environment for quick customization.		
<b>Model</b>	<b>IQT-HH20</b>	<b>IPT-HH20</b>	<b>IST-HH20</b>

## Handheld Interface Options and Accessories

### Interconnect Cables

Model Number	Description
<b>ODZ-MAH-CAB-B14</b>	USB cable, 6 ft.
<b>ODZ-MAH-CAB-B14-3.7M</b>	USB cable, 12 ft.
<b>ODZ-MAH-CAB-R2</b>	RS-232 cable, 8 ft. (requires ODZ-MAH-5V-110V power supply)
<b>ODZ-MAH-CAB-R6</b>	PS/2 keyboard wedge cable, 8 ft.
<b>ODZ-MAH-PWR-CABL</b>	Charging cable (requires ODZ-MAH-5V-110V power supply)



### Handles and Grips

Model Number	Description
<b>ODZ-MAH-GRIP</b>	Clip-on pistol grip (requires battery or battery blank and cable)
<b>ODZ-MAH-GRIP1</b>	Ruggedized cable handle (requires cable)
<b>ODZ-MAH-GRIP2</b>	Ruggedized battery handle, 1950 mAH*
<b>ODZ-MAH-GRIP3</b>	Ruggedized battery handle, 3900 mAH*



\*We continuously improve our products, consult factory for current mAH ratings.

### Bluetooth Modem

Model Number	Description
<b>ODZ-MAH-B15</b>	Wireless Bluetooth to USB, PS/2, or RS-232 (interconnect cable not included, see above)







# RFID for the Material Handling Industry

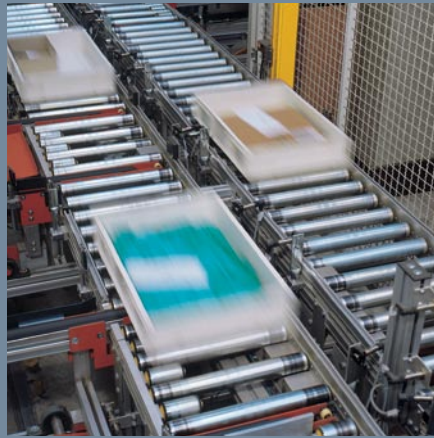

In the world of continuous movement, material handling links many diverse pieces of equipment. Applications demand outstanding RFID performance. With our experience in material handling techniques, you can be confident that Pepperl+Fuchs will provide solutions for your entire operation that nobody else can match.

- Pallet identification
- Large container tracking
- Forklift positioning
- Supply chain management
- Maintenance scheduling
- Item level tracking in pharmaceutical applications

### What Is An RFID System?

Radio Frequency Identification Systems or **RFID** has been in existence in some form for over 50 years. It is simply the wireless transmission of information from a transponder (tag) to a transceiver (read head). It started as a simple binary coded system where only a few bits of information could be stored at short read ranges and has evolved to thousands of bytes of storage at very long distances.

It is used to identify, track, sort and detect an infinite variety of objects, including people, vehicles, garments, containers, totes and pallets. It can be used in applications such as industrial closed loop tracking, pet/animal identification, package routing, passports, container tracking, inventory control, tollbooth auto payment, logistics, and access control.

### Components Of An Identification System

Typically, identification systems consist of a control unit, read/write heads and tags.

Unique identification and customer specific information can be saved in a targeted way on the tag. The read/write memory areas typically range in size from 1 kbit to 256 kbits. Read/write heads can read the tag and modify the read/write portion as required by the application. This is done with a series of commands sent by the control unit to the read/write heads and finally, to the tag.

Several read/write heads can be connected to one control unit, which also serves as the interface to the higher-level control. Communication takes place via the current fieldbusses such as Ethernet, PROFIBUS, DeviceNet, or via a serial interface. Wiring between the control unit and the read/write heads is accomplished via shielded cables in order to reduce the influence of EMC in the environment.

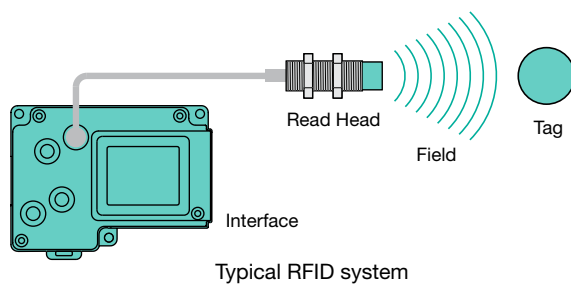

### Why Is It Worth Having An RFID System?

RFID systems save time and money. Product tracking and identification is possible throughout the entire assembly and distribution cycle. It reduces the need to manually collect data so that labor and error costs are reduced, and it makes the information available sooner.

An RFID system enables a manufacturing facility to find out if work in process has been misrouted and quickly correct the mistake. Data is accessible through handheld and fixed-mount

readers in real time, using RF signals to transfer data to and from tags, even in the absence of line-of-sight. The significant advantage of all types of RFID systems is the noncontact, non-line-of-sight nature of the technology. For instance, a "good" read can occur through sunlight, wet, cold (-40 °C), frost, dirt, grease, and many corrosive chemicals.

With RFID technology, companies can get real-time information on inventory. Manufacturers and suppliers can respond quickly to shifts in demand, avoid spoilage, and prevent over- and under-stocking.

- Ideal for dirty, oily, wet or harsh environments
- RFID is fast: tag and reader communicate in milliseconds
- RFID tags and readers have no moving parts so the system rarely needs maintenance and can operate for extended periods of time
- No line-of-sight requirement
- Long read ranges
- Track tools, vehicles, and equipment in real time

### Integration Into The Network Hierarchy

RFID systems are integrated at the process level of sensor technology. The control unit acts as an interface to the higher control system. Communication with the read/write heads and their parameterization takes place via this interface. All current fieldbus interfaces and serial connections are available for the RFID control units.

Commands of a PLC/PC application program are transmitted to the control unit via the fieldbus and then forwarded to the connected read/write heads. The responses are reported to the PLC/PC.

### Specifications, Standards, Directives

Memory in the code/data carriers is electrically and mechanically robust and offers a reading reliability of nearly 100% and a data retention time of more than ten years.

All components are produced according to the ISO 9001 International Standard and carry all the national and international certifications.

The directive for radio and telecommunications equipment (R&TTE, 1999/5/EC) also applies to identification systems. It defines certain requirements that are met by complying with the following standards: The relevant standards deal with the topics of health (e.g., EN 50371), EMC (e.g., EN 301489), use of the radio spectrum (e.g., EN 300330/EN 300440) and the electrical safety of equipment (e.g., EN 60950).

Pepperl+Fuchs is a member of AIM (Association for Automatic Identification and Mobility), which promotes the application and standardization of identification technology. Further information is available at [www.aimusa.org](http://www.aimusa.org).

### Frequencies

There are many frequency ranges available. They can all be grouped under the same RFID umbrella. Each frequency has its advantages and industries where it is often used. There are 3 major frequency bands available: low frequency 125/250 kHz, high frequency 13.56 MHz, and ultra-high frequency 2.45 GHz.

#### 125 and 250 kHz

The low frequency systems typically have a few inches of read range, are highly immune to metal in the environment and have good field penetration of water, grease and other nonmetallic substances. The wound coil required in a low frequency system makes the tag moderately expensive and typically requires the tags to be reusable and not disposable. This frequency range is ideal for factory automation, tool identification, closed loop parts tracking, animal tracking and inventory control.

##### Applications:

**AGVs** – In an automotive plant an AGV (Automated Guided Vehicle) often moves parts into position. The ID tag is located on the floor every few feet and the reader is on the vehicle. The AGV determines location by the most recent tag read.

**Paint** – Bodies are tracked during the paint process. Special high temperature tags are used to withstand this abusive and caustic environment.

**Sequence Verification** – The just-in-time transfer of parts from Tier 1 suppliers to assembly plants requires that the delivered parts are in order. Any sequence deviation will sound an alarm and the problem can be corrected.

**Parts Assembly** – The raw parts are assembled on a fixture and the fixture is tracked from one station to the next. Each station has a read head that verifies which operations are performed and sets pass/fail bits that are checked at the end of the production line.

**Access Control** – Often a user will carry a key fob tag or access card that is carried to access doors. The tag will verify entrance into the facility.

**Crane Positioning** – When moving product, a crane is positioned based on an X/Y coordinate system. The tag is mounted on the beams at the start of each aisle. When the crane reads that it has reached the correct aisle, it stops, moves into position and picks the part.

**Assembly** - Most consumer and factory automation products are produced on specialty machines. As the parts are produced, there may be model number changes or deviations that can easily be handled by an ID system. New parts come on line, and the work and test stations adapt automatically.

**Meat tracking** – Meat is hung on hooks as it is processed, and if a recall is necessary, the meat can be tracked. Because it can be determined where the contamination took place, less meat is recalled.

**Fluid Fill** – Some packaging applications involve filling liquid product into containers. The fluid fill station involves attaching

a hose to a port and verifying the fit. The tag is mounted on the collar of the hose and the read head at the fill port. The fluid will not flow until the read head reads the correct tag.

**Machine Tools** – Each tool has a tag flush mounted in steel. When the tool is mounted in the fixture the program verifies that it will work for the desired cutting operation.

#### 13.56 MHz

This frequency range allows a smaller coil size, which makes the tag less expensive. It is often used in logistical applications, asset tracking, and select factory floor applications. The low cost makes this tag perfect for high tag volume applications. These tags cannot be embedded in metal and are not appropriate for tool identification. In addition to being low cost because of the high frequency they are often 3 to 4 times faster than the low frequency versions.

##### Applications:

**Unit and Bulk Handling** – The small coil size and lower tag cost makes it possible to adhere the tags directly to boxes and containers.

**Assembly** – This frequency range is effective on high-speed production lines that require surface mounted tags and relatively large pallet sizes.

**Roller coaster car tracking** – Tag price is not a concern but the high speed tags can be very useful when reading the coaster as it passes at high speeds.

#### 2.45 GHz

This is P+F's highest performance system. These tags are in the 2.45 GHz range, the same range as Bluetooth, microwave ovens, some wireless home phones, and WiFi 802.11b/g access points. Because of higher tag prices, only long-range, high-speed applications are applicable. These long-range systems typically give a few meters of range. Tags are relatively large and active. Batteries last for 5-7 years and some tags have replaceable batteries. Perfect applications include automotive assembly, engine tracking, large container tracking, and mobile equipment.

##### Applications:

**Automotive assembly** – At the start of the assembly processes a tag is attached to the car. This tag is used on the line for tracking and at test stations to automate the production process. Consumable parts are automatically replenished to the line as the cars move through production.

**Material handling** – Large production lines of heavy equipment and large consumer goods often use these long-range systems because of read head mounting flexibility and the ability to read multiple tags in field.

**Amusement park rides** – Rides that are not on a specific track such as log rides and water rides require long-range read capability over a wide area. They are also used on trains because of their super fast read speeds.

**Truck Tracking** – As heavy equipment drives into aggregate processing facilities a tag on the truck is read and the system tracks everything, from pickup to delivery.

Trains – As trains move into stations or pass checkpoints, a high-speed reader relays information back to the tracking station.

### Comparison Between Frequencies

All of these frequency ranges bring advantages. It is important to select the right frequency for your application.

Read/write ranges for low and high frequency inductive systems (125 kHz-13.56 MHz) range from fractions of an inch to 1 foot. Read only and read/write tags typically operate passively and reflect or modulate the transmitted signals. These systems are particularly suitable for applications in the area of automation, material handling, data acquisition or the identification of objects such as storage containers, pallets, tool holders and similar items.

Identification systems with ultra-high frequency (~2.45 GHz) operate according to the principle of Hertz dipole in the far field, making it possible to reach larger read/write distances. Typical read/write range will be many feet. The code and data carriers have an energy source of their own to supply the internal electronic circuitry. Typical applications include the identification of larger objects in automotive production, or for simultaneous identification of several units on a conveyor line.

	125 kHz/250 kHz	13.56 MHz	2.45 GHz
<b>Wavelength</b>	2400 m, 1200 m	22 m	0.12 m
<b>Embeddable In Metal</b>	Yes	No	Yes
<b>Metal In Environment</b>	Yes	Some	Yes
<b>Penetration Through Water</b>	Very good	Average	None
<b>Reflections</b>	None	Low	Highest
<b>Electrical Interference</b>	Very High	High	Low
<b>Transfer Speed</b>	2-10 kbit/s	26 kbit/s	76 kbit/s
<b>Read Range</b>	150 mm	300 mm	4000 mm
<b>Write Ranges</b>	140 mm	250 mm	4000 mm
<b>Typical Application</b>	Tool ID, parts tracking	Pallet tracking, bin labels	Automotive, high speed
<b>Price Range</b>	\$3 - \$96	\$1 - \$39	\$62 - \$290

### RFID Systems Selection

#### Cycle Time

Typically, the higher the frequency the faster data can be transferred to and from the RFID tag. Other times must be taken into consideration to understand the complete system cycle time. You must take into consideration the following:

- Upper level bus-system scan times of networks like DeviceNet, PROFIBUS, Ethernet, and RS-232 will change depending on network loading, baud rate, etc.
- PLC scan time: The PLC may only see the rung that receives the RFID data every 30 ms. The cycle time of the entire system cannot be faster than the PLC scan time.
- Data transfer to and from the tag

#### Data Transfer Time

Each frequency and each RFID family have different read/write times. The possible data rates depend on the communication frequency. A 125 kHz system, for example, offers typical data rates of 40/120 bytes per second (write/read) and a high frequency system offers 130/230 bytes per second. Additional time must be calculated for the data transfer on the fieldbus and processing in the PLC. This may be a determining factor for installation, and will be required if read-on-the-fly speeds need to be calculated. Typically, the more you want to read the more time it will take.

#### Maximum Passing Speed

The passing speed is calculated using the data transfer time between the tag & head, and the field size. The field size is based on the size of the read head. The larger the head the more time the tag can stay in the field and the faster the tag can pass. See the following graphs for the recommended spacing between the tag and the head. Being too close or too far away can reduce the performance of the system.

Easy conversions:  
 1m/s = 197 ft/min  
 1m/s = 3.28 ft/sec

RFID Systems Selection Chart

	IDENT Control				IDENT I
	Series P	Series S	Series Q	Series MV	System P
<b>Frequency</b>	125 kHz	250 kHz	13.56 MHz	2.45 GHz	125 kHz
<b>Read Head Sizes Available</b>	6	3	3	2	1
<b>Tag Models Available</b>	25+	19+	6+	1	19+
<b>Max Passing Speed</b> <i>Read Only</i>	4 m/s	15 m/s	13 m/s	287m/s	2 m/s
<i>Read Data (4 Bytes)</i>	1 m/s	8 m/s	19 m/s	135m/s	.85 m/s
<b>Memory Capacity (Bits)</b>	928, 64k	1k	896, 2k	59k	928, 64k
<b>Max Read Distance</b>	150 mm	92 mm	300 mm	4000 mm	100 mm
<b>Max Write Distance</b>	140 mm	77 mm	250 mm	4000 mm	90 mm
<b>Mounting In Metal</b>	Yes	Yes	No	Yes	Yes
<b>On Metal</b>	Yes	Yes	Yes	Yes	Yes
<b>Protection Class</b>	IP68	IP68	IP67	IP67	IP68
<b>Bus Connections</b> <i>Serial</i>	●	●	●	●	●
<i>DeviceNet</i>	●	●	●	●	●
<i>PROFIBUS</i>	●	●	●	●	●
<i>Ethernet</i>	●	●	●	●	●
<b>Multiple Tags In Field</b>	No	No	Yes	No	No

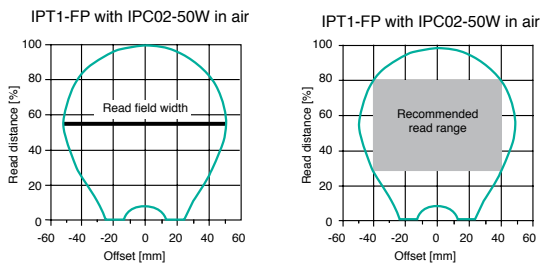

Generally, the following rule applies:

$$V_{\max} = \frac{\text{Read field width [m]}}{\text{Read time [s]}}$$

For inductive systems, if the object passes at about half the maximum read distance, the diagonal of the read head can be used as the read field width if the code/data carrier has roughly the same diameter as the read head.

Typically only 1/2 to 1/3 of the maximum passing speed is recommended for practical use. This will take into consideration retries required due to noise and interference on the line. Though retries are highly unlikely they are a necessity on any industrial interface.

### Read speed in meters/second

Read Head	Read Field Width	Read Only	Special High-Speed Read	4 Bytes Read
IPH-18...	25	0.625		0.192
IPH-30.../ IPH-F61...	42	1.050		0.323
IPH-L2-V1	56	1.4		0.431
IPH-FP-V1/IPT1-FP	110	2.750		0.846
IPH-F15-V1	195	4.875		1.500
ISH-18GM-V1	25	3.571	5.000	1.923
ISH-F61-V1	42	6.000	8.400	3.231
ISH-FP-V1	110	15.714	22.000	8.462
IQH-18GM-V1	25	1.220		1.761
IQH-FP-V1	110	5.366		7.746
IQH-F100-V1	280	13.659		19.718
MVH500-F15-V1	1000	125.000		58.824
MVH2000-F15-V1	2300	287.500		135.294

## Tags

There are many tags to choose from. Choose a tag by considering the following and by selecting the features required for your application.

- Choose a frequency
- Choose read only or read/write (if applicable)
- Choose tag size/mounting

## Operating Range

The read and write range specified is not the maximum range, but rather, a conservative number taking into account that your installation will have temperature changes, misalignment, noise, mutual interference and so on. In the following graph the maximum read range of the IPH-L2-V1 and the IPC03-20W is about 49 mm. The recommended tag mounting location is between 30% and 80% of the maximum measured range.

An example of the Read Field curves are shown here. For optimal read-on-the-fly performance the tag should be positioned 40% to 60% of the maximum read range away from the read head. This will ensure maximum passing speed is possible.

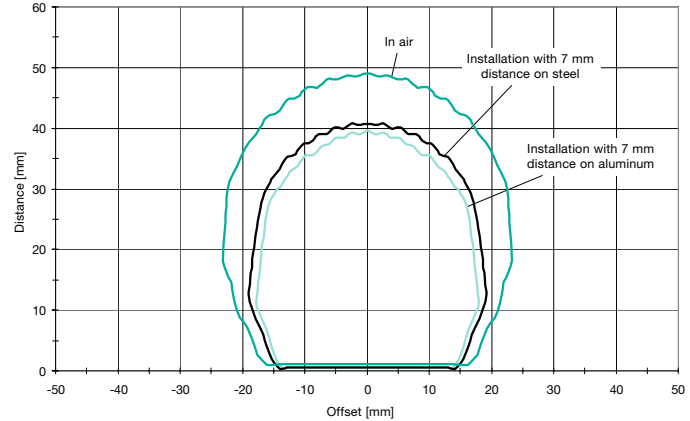

## Write Cycles

Many installations require writing to the tags frequently. The rated write cycles assume a data retention period of about 10 years. So if an IPH head writes to a single memory location 100,000 times, the retention of the data on that last write will be 10 years.

One difference between the IPC03 and IDC heads is the write access mechanism. The IPC03 tags have 29 registers, each of which can be written 100,000 times. In some installations the PLC/PC automatically moves up the register structure of the tag and this method can give you over 2.9 million write operations on one tag. The IDC tags, on the other hand, have a 500,000 write limit whether you access 1 word or the entire tag. Data on this tag will be retained for over 18 years.

One option for applications requiring frequent writing to the tag is to choose the IPC12 FRAM tag. This technology allows unlimited write operations. Because the tag takes more power to activate, only 1/2 the read/write range can be achieved. As with every other low and high frequency tag, no battery is required.

## Tag/Head Size Choices

It is important to note that if you choose a small tag, you should choose a small head. There is very little to be gained in a mismatch either way. The most efficient combinations are those where the head is similar in size to the tag.

## Data Retention

When data is written to a tag, the data will remain on the tag at room temperature for 10 years. If the temperature goes up the retention period could go down. The only way to refresh the data is to rewrite it. Reading has no effect on refreshing the data on the tag. It is always good to have a write station in your installation so you have the ability to rewrite the tags at the 10-year mark. If you always write to the tags, there is no concern.

Tag Selection Table

Frequency	125 kHz				250 kHz		13.56 MHz		2.45 GHz
Model	IPC02	IPC03	IPC11	IPC12	ICC	IDC	IQC21	IQC22	MVC
Tag Type	Read only	Read/Write	WORM	FRAM	Read only	Read/write	Read/write		Read/write
Mounting	In Air	●	●	●	●	●	●	●	●
	In Metal	●	●	●		●			
	On Metal	●	●		●	●	●		●
Tag Capacities (bits)	40	928	40	65,536	28	1,024	896	2,048	60,415
Max Read Range (mm)	100	150	100	55	92	92	250	300	4,000
Write Limits	0	100,000	1 or 100,000	Unlimited	0	500,000	100,000	100,000	Battery life
Battery, Replaceable									●
High Temp	●	●			●				

### Tag Mounting

We have the read/write ranges listed for each tag in a number of different mounting configurations.

The first read/write range measured is in air. This range information can be used if you are going to mount your tag on plastic, glass or any other nonmetallic material. The second measurement is taken with the tag mounted on steel. Aluminum may also be listed, and this read/write data will be similar or a few percent less than mounting on steel. The last mounting option will be the tag flush in steel. These tags can be mounted with no air gap around them. Also, some tags have their ranges measured with a spacer. In this case the spacer thickness will be listed and the ranges specified.

### Spacers

A spacer is used to separate any tag from metal. Some tags have built-in spacers and are designed to mount directly on metal. These tags will have a thicker housing from 1/2" to 3/4" and typically have a center mounting hole. For the low-frequency systems, the following reduction factors should be taken into consideration when compared to reading in air.

- 3/4" spacer      10% reduction in read/write range
- 1/2" spacer      15% reduction in read/write range
- 1/4" spacer      20% reduction in read/write range

### Adhesives

There are many adhesive manufacturers including: 3M Adhesives, Loctite, Armstrong Epoxies, and Lord. We do not specifically recommend a particular adhesive because the required product will vary depending on the application. Certain factors mandate one product over another due to temperature, bonding of similar and dissimilar materials, chemical resistance, and resistance to light. Often, our plastic tags are mounted in metal. These two dissimilar materials will expand and contract at different rates. Make sure the hole is large enough to account for this change, and use an epoxy that is a flexible. If the epoxy is too hard, thermal expansion could put the tag under a great deal of stress.

FYI: Huntsman offers a product called Araldite and we have been successful with this epoxy. Visit their website and use the product finder to pick the right formula for your application at [www.huntsman.com](http://www.huntsman.com).

### Tag Removal

If you want to be able to remove a tag, try using one of our 16 mm or 30 mm threaded tags. We have tools that make it simple to install or remove the tag without damage.

### Mounting Considerations

The read and write distances specified in the distance table must be observed in the application. Mechanical tolerances must also be considered in order to avoid zero points and double readings. If possible, the read/write heads and the data carriers should have a similar size (e.g., IPH-FP-V1 head with a coil size of approx. 70 mm diameter and code carriers with 50 mm diameter) such that the electromagnetic coupling in the near field is optimized.

Metal located in the environment of the read heads and the code carriers reduces the possible read/write distances. For this reason, minimum distances must be observed or special code carriers designed for this purpose must be used. The following distance table will help you in mounting your read heads and tags to minimize the effect due to metal in the environment. Minimum read head spacing should also be observed to minimize potential mutual interference problems.

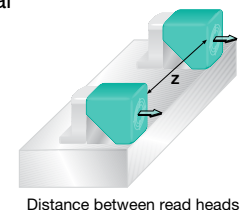
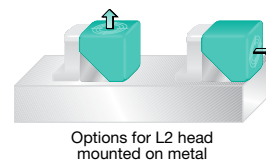
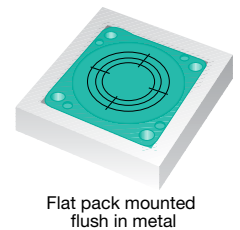
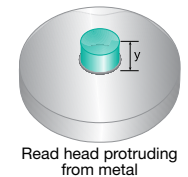
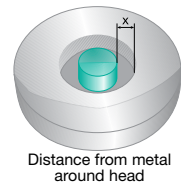

### Mounting tolerances on metal

Housing Type	X	Y	Z
M18	> 14 mm	Height of the plastic unshielded cover	see datasheet
M30	> 15 mm		see datasheet
F61	> 30 mm	Mount on metal	see datasheet
L2	> 50 mm	Mount on metal	see datasheet
FP	> 0 mm	Flush in metal	see datasheet
IPT1-FP	>75 mm	Mount on metal	see datasheet
F15	> 100 mm	Mount on metal	see datasheet







# IDENT Control

**Overview ..... 25-29**  
**System Interfaces ..... 30-33**  
**Series Q (13.56 MHz) ..... 34-37**  
**Series P (125 kHz) ..... 38-47**  
**Series S (250 kHz) ..... 48-55**  
**Series MV (2.45 GHz) ..... 56-58**

## Overview

IDENT Control is an innovative new approach to RFID read/write technology. Any type of read head connects directly to the IDENT Control Interface. A long-range 2.45 GHz read head connects to the same interface as a 125 kHz short-range system.

The advantage is not merely the simplicity of the system, but the easy and universal programming. No matter which head is used, the PLC or PC programming is the same. All heads use the same commands and all tags have the same addressing structure.

## Mounting

Mounting is easy with the rugged cast aluminum housing. The system provides two mounting options: (1) in the cabinet with DIN rail and (2) in the field using the three mounting holes.

## Power

All interfaces, regardless of the fieldbus system, are powered by 24 VDC and the M12 connector adheres to the industrial standard where pin 1, brown, is positive and pin 3, blue, is negative. This makes wiring simple. Reverse polarity is indicated by the red LED and a green LED means the wiring is correct.

## Quick Disconnect

All connectors on the IDENT Control Interface are quick-disconnect style. This eliminates loose, disconnected, or intermittent wiring. If a cable is damaged, replacing it with a new one takes only a few minutes with no tools or wiring diagrams.



## Grounding and Shielding

IDENT Control is completely shielded and grounded. The interface has a grounding lug, and all read heads have a metal connection to ground it to the machine. All read head cables have a shield that is connected directly to the coupling nuts on both sides. This enables a continuous shield from the bottom of the interface directly to the read head. No noise or interference enters or exits the interface. All EMC is grounded through the low impedance connections at the head or the interface.

## Graphical Display

The IDENT Control interface consists of four function keys for programming, and a 2-line, 12-character display that is perfect for configuration and diagnostic retrieval. There is an LED indication for each read head to ensure proper connection. An IPH indicator ensures proper read head configuration.

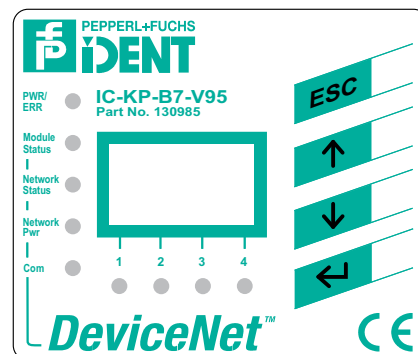

## Multiplex Mode

When two read heads with the same frequency are in close proximity, and the commands are sent at the same time, there could be interference. With the multiplex mode, the heads are interrogated one at a time to eliminate mutual interference. There is no noticeable difference in the programming from the PLC/PC. This feature can be set/reset using the graphical display or your program.

## Command Activation and Testing

A big advantage of the IDENT Control interface is the ability to debug the system before it is attached the upper level bus. The system enables you to activate the commands on the display before it is connected in order to optimize read head mounting, test read/write range, check the tag type settings, and adjust the trigger settings. These commands are for debug only and when running will not send any data to your upper level system or program.

## Read Heads

With IDENT Control, all heads are read/write. There are no worries about purchasing the wrong head style so inventories are significantly reduced. Seven different housing designs are available for your application requirements.

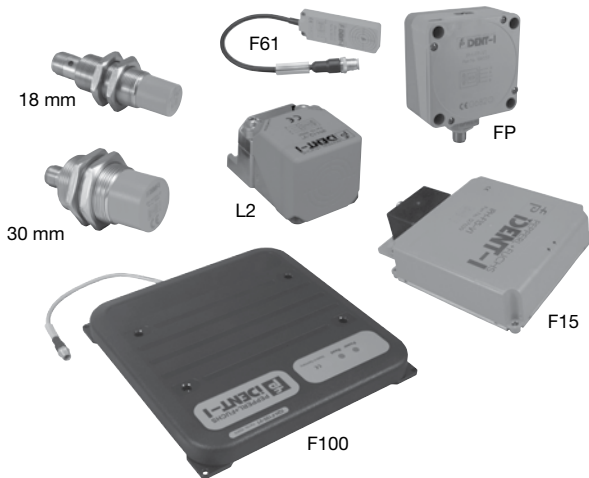

All read heads fit and work on any IDENT Control interface.

	Series P	Series S	Series Q	Series MV
<b>Frequency</b>	125 kHz	250 kHz	13.56 MHz	2.45 GHz
<b>Read Head Sizes Available</b>	6	3	3	2
<b>Tag Models Available</b>	25+	19+	6+	1
<b>Transfer Rate</b>	2 kbit/s	20 kbit/s	26 kbit/s	76.8 kbit/s
<b>Tags Embeddable In Metal</b>	Yes	Yes	No	Yes
<b>High Temperature Tags</b>	Yes	Yes	No	No
<b>Tag Capacities (bits)</b>	1k, 64k	1k	1k, 2k	64k
<b>Max Read Range</b>	150 mm	92 mm	300 mm	4 m
<b>Write Limits</b>	100,000 or unlimited	500,000	100,000	Depends on battery life
<b>Battery, Replaceable</b>	-	-	-	Yes

## How Do I Choose the Correct Head?

The first factor is the frequency. If you have chosen a tag then select a read head with the same frequency as the tag. Second, consider the IPH... type read heads. This line of RFID has the widest selection of tags and heads. Odds are that there is something in this line that will fit your application. Third, use the preceding table to determine which features you need for your application.

## Industrial Applications Around Metal

The best heads to use around metal are the IPH... and the ISH... heads. The IQH... heads typically have larger read range reductions in these environments and require large heads/tags to achieve the same range.

## Read Speed

There are usually two speeds that are discussed when it comes to RFID. The first is how fast can the data be read off the tag, and the second is how fast can the tag fly by the read head and still be read. The second speed is based on the first, but it also takes into consideration the size of the head and size of the tag. Basically, the higher the frequency, the faster the data can be read; and the larger the head the faster the tag can pass the reader. See the RFID introduction to determine how each system performs.

## Tags

There are over 50 different tags in a variety of housings and performance ratings. Tags can range in diameter from 8 mm to 100 mm. Industrial tags are designed for tough and abusive environments: very high or low temperatures, excessive wear and tear, and mounting in or on metal. Commercial tags are less costly and can be used where very little abuse is expected. We have the right tag for virtually any application.



## Read Head And Trigger Connections

The IDENT Control interface allows the connection of up to 4 heads, and 2 of these can be replaced by trigger sensors. Each trigger sensor will be associated with 1 read head to quickly read or write data automatically without upper-level decision making. Trigger sensors allow complete distributed control where tags are read immediately, and data is sent directly to the control system.

## Industrial Bus Connections

Just like any RFID system, bus connections are required to connect and program the interface. All bus connections are integral to the IDENT Control housing. Just choose an interface, read head and cable and you are done. Four bus connections are available: Ethernet, DeviceNet, PROFIBUS, and RS-232. The Ethernet interface will support multiple protocols, including EtherNet/IP, PROFINET, PCCC for SLC5/05 and PLC5 messaging, Modbus/TCP, and TCP/IP. Protocol switching is automatic.



DeviceNet.

RS-232



## EtherNet/IP, DeviceNet, and PCCC

CIP is the common link between EtherNet/IP and DeviceNet. Both use the same software stack, making programming easy and seamless for the user. If you program over Ethernet for the Allen-Bradley ControlLogix and switch to DeviceNet the programming doesn't change. If you program using DeviceNet on the SLC500 and switch to Ethernet on the PLC 5, the transition is quick and easy. This PCCC protocol emulates the PLC5 reading and writing MSG instructions. You can communicate over Ethernet to the SLC5/05, PLC5, ControlLogix, and CompactLogix.

## Modbus/TCP

This protocol is very simple to use and has some powerful features. Multiple simultaneous users can access IDENT Control at the same time. This may be 4 PLCs accessing each read head separately or PCs running test systems and diagnostic applications.

## TCP/IP and Web Configuration

You can use a standard socket connection to communicate to IDENT Control. Another nice advantage of IDENT Control is the built-in web page used for diagnostics and setup of your system.



A unique feature of the web site includes the command entry window. If not connected to the PLC, you can access IDENT Control from the web browser and send and receive commands.

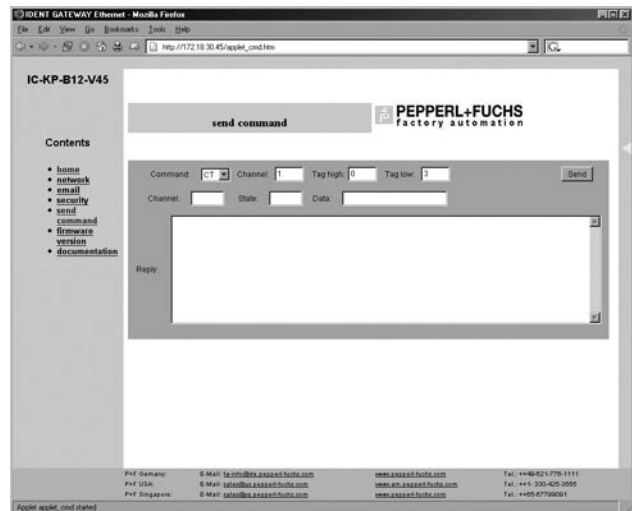

Another powerful feature is sending email using the built-in SMTP server. The system can be set to send an email if there are any errors i.e., the read head was disconnected. During the debug process you can also set the system to send an email of data that is being read or when a tag was written.

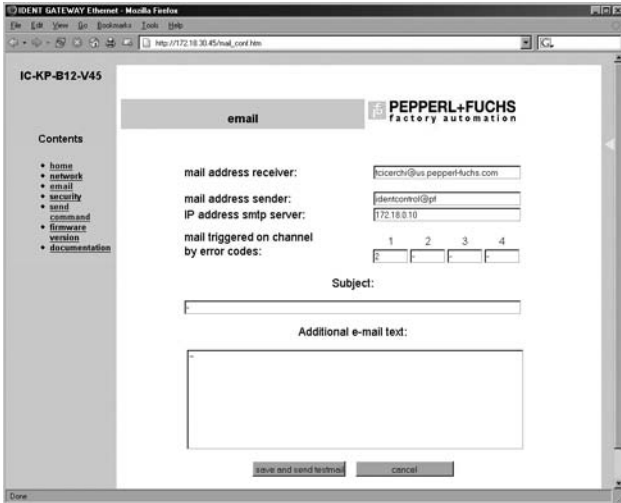

## Serial RS-232

The RS-232 interface may be a good choice if you frequently write your own applications or like the flexibility of serial communications. One advantage of this connection is the ability to read and write a great deal of data at one time. A single operation can read or write over 1000 bytes of data at one time assuming the tag supports it.

## Choosing the Right Connection For Your PLC

Your existing PC or PLC typically determines which IDENT Control interface you'll use. Some PLCs program better with one network than another. There are always other network options, but these are often more difficult to program than the primary network of choice. In many cases, a network interface card is required.

PLCs/control systems and the suggested network of choice for IDENT Control:

Manufacturer	PLC Model	Network First Choice	Network Second Choice
Allen-Bradley	SLC 5/03, SLC 5/04	DeviceNet, IC-KP-B7-V95	PROFIBUS, IC-KP-B6-...
	SLC 5/05	Ethernet, IC-KP-B12-V45	DeviceNet, IC-KP-B7-V95
	ControlLogix	Ethernet, IC-KP-B12-V45	DeviceNet, IC-KP-B7-V95
	CompactLogix	Ethernet, IC-KP-B12-V45	DeviceNet, IC-KP-B7-V95
	MicroLogix	DeviceNet, IC-KP-B7-V95	Ethernet, IC-KP-B12-V45
Siemens	PLC5/80E	Ethernet, IC-KP-B12-V45	DeviceNet, IC-KP-B7-V95
	S7	PROFIBUS, IC-KP-B6-...	Ethernet, IC-KP-B12-V45
Omron	CS1	DeviceNet, IC-KP-B7-V95	PROFIBUS, IC-KP-B6-...
	CJ1	DeviceNet, IC-KP-B7-V95	PROFIBUS, IC-KP-B6-...
Schneider Electric	Momentum	Ethernet, IC-KP-B12-V45	PROFIBUS, IC-KP-B6-...
	Premium	Ethernet, IC-KP-B12-V45	PROFIBUS, IC-KP-B6-...
	Quantum	Ethernet, IC-KP-B12-V45	
GE	90-30	Ethernet, IC-KP-B12-V45	PROFIBUS, IC-KP-B6-...
	90-70	Ethernet, IC-KP-B12-V45	
	VersaMax	DeviceNet, IC-KP-B7-V95	
Mitsubishi	A/QnA	DeviceNet, IC-KP-B7-V95	PROFIBUS, IC-KP-B6-...
	AnSH	DeviceNet, IC-KP-B7-V95	PROFIBUS, IC-KP-B6-...



## IDENT Control System Interfaces

- 10/100 Mbit Ethernet for EtherNet/IP, PROFINET, Modbus/TCP, TCP/IP, or PCCC
- Industrial interface options for DeviceNet, PROFIBUS and RS-232
- Graphical display and LED diagnostic indicators
- Cast aluminum housing 100% shielded



The IDENT Control Interface is the backbone of the entire RFID system. It connects directly to your PC/PLC of choice and manages all communications to and from the 4 read heads. Read heads are configured on power up, and parameters, like multiplex mode and tag type, are set automatically.





### Mixed Mode vs. Separated Mode

A feature that could make you choose one interface over another is the mode of operation. You can read and write to all heads simultaneously. The key difference is the memory mapping in the PLC. In the Mixed Mode operation, all heads respond to the same location in PLC memory. In Separated Mode, memory is set aside for each head. Mixed Mode is great for reducing bus system overhead and Separated Mode is used for speed and programming ease.

### EtherNet/IP

The Ethernet interface supports EtherNet/IP right out of the box. With implicit messaging, the data is directly mapped just like any other I/O card. No expensive configuration software is required for setup. Everything is programmed using the RSLogix 5000 programming software.

## Common Specifications

LCD DISPLAY	2 lines, 12 characters	
OPERATING VOLTAGE	10-30 VDC	
VOLTAGE RIPPLE	≤ 10% at 30 VDC	
REVERSE POLARITY PROTECTION	Yes, with red LED indication	
HUMIDITY	96% noncondensing, salt spray resistant	
TEMPERATURE RANGE	Working	-13°F to +158°F (-25°C to +70°C)
	Storage	-22°F to +176°F (-30°C to +80°C)
HOUSING MATERIAL	Aluminum, powder coated	
WEIGHT	35.3 oz.	
APPROVALS	 	
READ HEAD CONNECTION		4-pin female M12 quick disconnect
POWER CONNECTION		4-pin male M12 quick disconnect

### TCP/IP

Standard socket connections to port 10000 will allow you to send and receive data to IDENT Control. An integrated Web server makes configuration, setup and testing easy and with the integrated SMTP server emails are sent on error or data.

### DeviceNet

Because the DeviceNet current consumption is only 40 mA you can run 500 ft of DeviceNet cable with more than 84 read heads attached to it. DeviceNet also has automatic node replacement. With this feature, all parameters are downloaded to the interface on power up. These parameters may include the assembly instances, tag type of each head and multiplex mode.

### SLC 5/05 and PLC 5 Read/Write Operation

The SLC5/05 Ethernet processor and the PLC5/xxE Ethernet processors do not use standard EtherNet/IP protocol, but use a protocol called PCCC. This protocol is fully supported and two rungs of ladder will get you up and running quickly.

### Modbus/TCP

Many PLCs, such as Modicon and GE, will support the Modbus/TCP protocol. This protocol supports multiple simultaneous users, one PLC can control four heads or four PLCs can each control one head. This reduces the overall cost of the installation. The interface is protected against dual head write access.

### PROFIBUS

Many PLCs use PROFIBUS as their high-speed bus connection. Two models are available that allow quick field or enclosure mounting. Parameterization is automatic, and the diagnostic interrupt allows signaling of the master system when an error occurs.

MODEL	IC-KP-B12-V45	IC-KP-B7-V95	IC-KP-B6-SUBD	IC-KP-B6-V15B	IC-KP-R2-V1
PROTOCOLS	EtherNet/IP, PROFINET, TCP/IP, Modbus/TCP, PCCC	DeviceNet	PROFIBUS DP		RS-232, P+F ascii
BAUD RATES	10/100 Mbps	125, 250, 500 kbps	Up to 12 Mbps		38.4 kbps
ADDRESS	Fixed IP address, DHCP	0-63	0-126		-
READ HEAD MAPPING	Separated/mixed mode	Separated/mixed mode	Mixed mode		-
MIN./MAX. DATA MAPPING SIZES	8 bytes/248 bytes	8 bytes/248 bytes	8 bytes/64 bytes		-
MAX. READ/WRITE DATA IN SINGLE SCAN	60 bytes (Modbus/TCP, TCP/IP), 56 bytes (EtherNet/IP)	56 bytes	60 bytes		1020 bytes
MESSAGING	Explicit, implicit, fc3, fc16, fc23	Polled, COS, explicit	DPV0		-
POWER CONSUMPTION (WITHOUT READ HEADS)	3.5 W	2.5 W	3.5 W		2.5 W
BUS CURRENT CONSUMPTION	-	40 mA	-		-
PROTECTION (IEC)	IP67	IP67	IP40	IP67	IP67
BUS CONNECTION	RJ45 + amphenol	7/8" mini	9-pin D-sub	Male M12 B-coded quick disconnect	Female M12 quick disconnect

## Wiring Diagrams

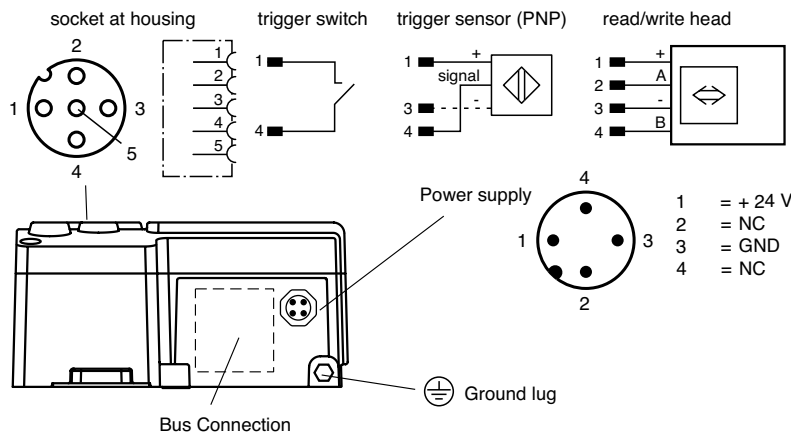

IC-KP-B12-V45

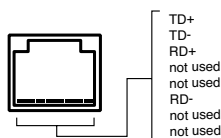

IC-KP-B7-V95

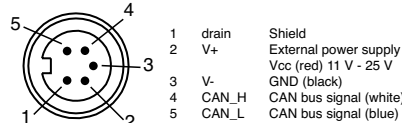

IC-KP-B6-SUBD

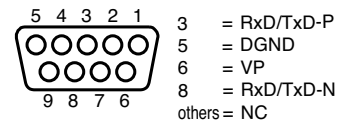

IC-KP-B6-V15B

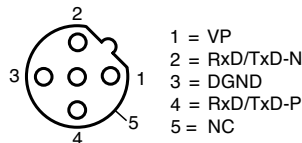

IC-KP-R2-V1

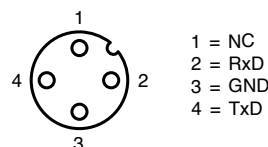

## Dimensions (mm)

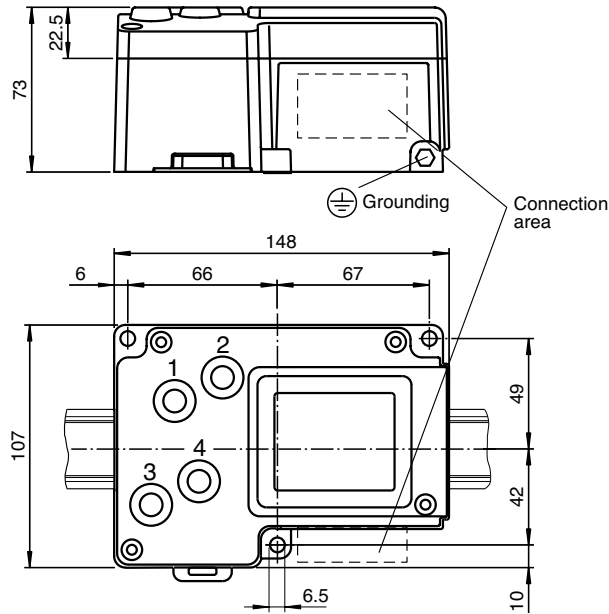

## Accessories

### Power Cables



Model	Description
V1-G-2M-PUR	Length 2 m, PUR jacket
V1-G-5M-PUR	Length 5 m, PUR jacket
V1-G-10M-PUR	Length 10 m, PUR jacket
V1-G-2M-PVC	Length 2 m, PVC jacket
V1-G-5M-PVC	Length 5 m, PVC jacket
V1-G-10M-PVC	Length 10 m, PVC jacket



### Power Distribution Using Flat Cable with Piercing Technology

Model	Description
VAZ-FK-R-BK	Flat black cable, 8 A oil resistant
VAZ-FK-S-BK	Flat black cable, 8 A standard
VAZ-T1-FK-.3M-PUR-V1-G	Flat cable power adapter, length .3 m
VAZ-T1-FK-1M-PUR-V1-G	Flat cable power adapter, length 1 m
VAZ-2FK-B3	Flat cable splitter for machine breaks
VAZ-FK-ST1	Shrink tube to cover open ends (20)

### Read Head Cables

Model	Description
V1-G-.6M-PUR ABG-V1-W	Length .6 m
V1-G-5M-PUR ABG-V1-W	Length 5 m
V1-G-10M-PUR ABG-V1-W	Length 10 m
V1-G-20M-PUR ABG-V1-W	Length 20 m



### Ethernet Accessories

Model	Description
ICZ-V45	RJ45 protective cover
V45-G-10M-V45-G	RJ45 cable, shielded 10 m



See pages 83-96 for complete RFID accessory listing.



## Accessories

### RS-232 Accessories

Model	Description
V1S-G-0.15M-PUR-SUBD	M12 to DB9 adapter .15 m
VAZ-R2-NULL	DB9 null modem cable 5 m



### DeviceNet Accessories

Model	Description
DNV95-G-TERM	MINI terminator 5-pin female
DNV95-G-0M-T-0M-V95-G-L	MINI tee
DNV15-G-YE1M-PVC-V95-G	Micro female to MINI male adapter 1m
DNV95-G-BK5M-PVC-V95-G	MINI double-ended cable 5 m
DNV95-G-BK15M-PVC-V95-G	MINI double-ended cable 15 m
DNV95-G-BK25M-PVC-V95-G	MINI double-ended cable 25 m
DNV95-G-BK50M-PVC-V95-G	MINI double-ended cable 50 m



### PROFIBUS Accessories

Model	Description
ICZ-3T-V15B	B-coded tee
ICZ-TR-V15B	B-coded terminator
ICZ-3T-0.2M-PUR ABG-V15B-G	B-coded y cable
ICZ-2T/TR-0.2M-PUR ABG-V15B-G	B-coded y cable termination
V15B-G	B-coded field attachable female
V15SB-G	B-coded field attachable male
V15B-G-0.6M-PUR ABG-V15B-G	B-coded extension cable .6 m
V15B-G-1M-PUR ABG-V15B-G	B-coded extension cable 1 m
V15B-G-2M-PUR ABG-V15B-G	B-coded extension cable 2 m
V15B-G-5M-PUR ABG-V15B-G	B-coded extension cable 5 m
V15B-G-7M-PUR ABG-V15B-G	B-coded extension cable 7 m
V15B-G-12M-PUR ABG-V15B-G	B-coded extension cable 12 m
V15B-G-15M-PUR ABG-V15B-G	B-coded extension cable 15 m
VAZ-PB-CABLE	Raw PROFIBUS cable 100ft
VAZ-PB-DB9-W	DB9 PROFIBUS connector with termination switch



See pages 83-96 for complete RFID accessory listing.

## IDENT Control Series Q Read Heads and Tags

- ISO 15693 standard 13.56 MHz HF system
- Low cost adhesive-backed tags optional
- 26 kbit/s high speed reading
- 1 k and 2 k read/write data capacity





The Series Q read heads and tags are designed around the ISO standard 15693. This ISO standard guarantees the availability of this technology for years to come. The high frequency transmission of data to and from the tag is ideal for applications requiring a large amount of data transferred at high speeds.

### Commercial/Industrial Housings

P+F offers two types of housing styles for Series Q. Industrial applications often use the 30P, 50P, or 58 mm tags for maximum mechanical protection and IP68 watertight housings. Commercial applications, or industrial applications planning to repackage the tag into a new housing, often don't require this type of protection. Open loop or supply chain applications may use the tag for only a few days requiring a disposable version.

### Common Specifications

#### Series Q Read Heads

LED FUNCTIONALITY	Green power, amber tag read	
OPERATING VOLTAGE	From IDENT Control	
TEMPERATURE RANGE	Working	-13°F to +158°F (-25°C to +70°C)
	Storage	-40°F to +185°F (-40°C to +85°C)
APPROVALS	  	

#### Series Q Tags

OPERATING FREQUENCY	13.56 MHz
DATA TRANSFER RATE	26 kbit/s

### Low-Cost Adhesive Backed Tags



Many industries require high volume disposable tags. In this case, a paper or plastic-backed tag with adhesive may be required. Due to varying applications these tags are not listed here. Adhesives will vary depending on the application, as well as the size, thickness, and backing material. All of these options add up to hundreds of tag variations. Please contact P+F sales support with application specifics for assistance in selecting the correct tags.

### Operating Range

Read ranges for Series Q are comparable to similarly sized low-frequency read heads. Mounting the tag to metal, however, may reduce the range by more than 50%. Using a spacer when mounting the tag on metal is usually required; the thicker the spacer, the larger the read range. Series Q offers a read head in an F100 housing, our largest available. The F100 housing supplies a read/write range of up to 1 foot in nonmetallic applications.



## Series Q Read Heads

HOUSING STYLE	18 mm	Flat Pack	F100
MODEL	<b>IQH-18GM-V1</b>	<b>IQH-FP-V1</b>	<b>IQH-F100-V1</b>
MOUNTING	<i>Min. distance between heads, multiplex OFF</i>	80 mm	500 mm
	<i>Min. distance between heads, multiplex ON</i>	30 mm	180 mm
POWER CONSUMPTION	1.2 W	2 W	1.3 W
PROTECTION (IEC)	IP67		IP54
HOUSING MATERIAL	PBT/stainless steel	PBT/aluminum	ABS
WEIGHT	1.4 oz	13.4 oz	35.3 oz
ELECTRICAL CONNECTION	 4-pin male M12 quick disconnect	 4-pin male M12 quick disconnect	 200 mm pigtail, 4-pin male M12 quick disconnect

## Dimensions (mm)

IQH-18GM-V1

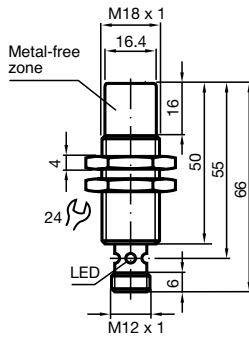

IQH-FP-V1

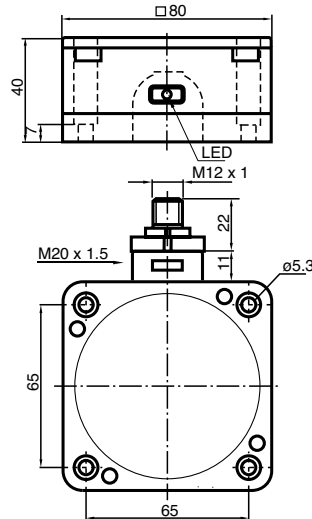

IQH-F100-V1

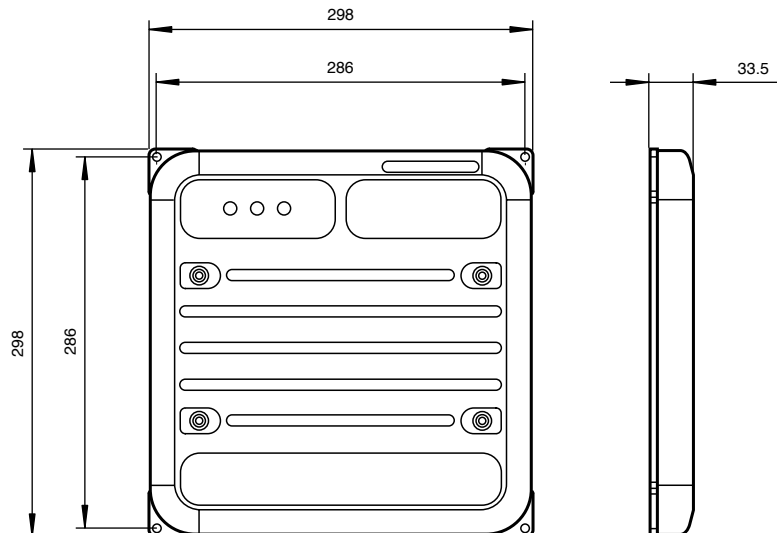



## Series Q Tags

TYPE	Read/Write		
MODEL	IQC21-30P	IQC21-50P	IQC21-58
ISO STANDARD/CHIP TYPE	ISO 15693 I-Code SLI		
READ SPEED	(4.9 ms each 4 byte word) + 9.3 ms, 20.5 ms read only		
WRITE SPEED	(28 ms each 4 byte word) + 1.6 ms		
READ/WRITE MEMORY	112 byte EEPROM		
READ ONLY MEMORY	8 byte ROM		
WRITE CYCLES	> 100,000		
DATA RETENTION	10 years at 55°C		
READ/WRITE RANGE IN AIR (AT 25°C)	IQH-18GM-V1 0-37 mm	IQH-18GM-V1 0-58 mm	IQH-18GM-V1 -
	IQH-FP-V1 0-66 mm	IQH-FP-V1 0-102 mm	IQH-FP-V1 -
	IQH-F100-V1 -	IQH-F100-V1 0-250 mm	IQH-F100-V1 -
READ/WRITE RANGE ON METAL (AT 25°C)	IQH-18GM-V1 -	IQH-18GM-V1 -	IQH-18GM-V1 0-35 mm
	IQH-FP-V1 -	IQH-FP-V1 -	IQH-FP-V1 0-70 mm
	IQH-F100-V1 -	IQH-F100-V1 -	IQH-F100-V1 0-160 mm
PROTECTION (IEC)	IP68		
TEMPERATURE RANGE	Working	-4°F to +212°F (-20°C to +100°C)	-13°F to +158°F (-25°C to +70°C)
	Storage	-4°F to +212°F (-20°C to +100°C)	-13°F to +185°F (-25°C to +85°C)
HOUSING MATERIAL	PC		ABS
MOUNTING CONSIDERATIONS	#4 pan head max 4-6 in-lb torque	#6 flat head max 4-8 in-lb torque	#10 flat head max 10-20 in-lb torque

## Dimensions (mm)

IQC21-30P

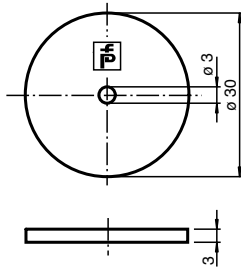

IQC21-50P

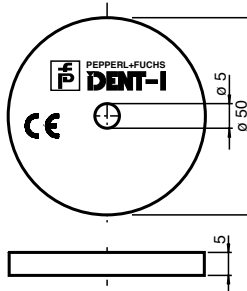

IQC21-58

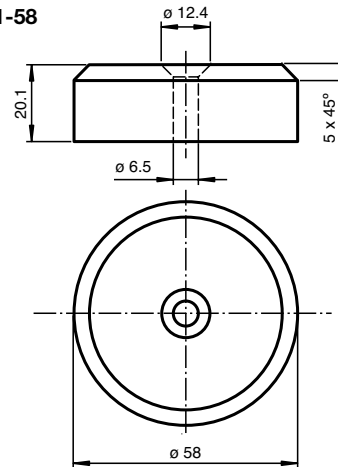



## Series Q Tags

TYPE	Read/Write		
MODEL	IQC22-C5	IQC22-C1	IQC22-C4
ISO STANDARD/CHIP TYPE	ISO 15693 Tag-it HF-I		
READ SPEED	(4.9 ms each 4 byte word) + 9.3 ms, 20.5 ms read only		
WRITE SPEED	(21 ms each 4 byte word) + 1.6 ms		
READ/WRITE MEMORY	256 byte EEPROM		
READ ONLY MEMORY	8 byte ROM		
WRITE CYCLES	> 100,000		
DATA RETENTION	10 years at 55°C		
READ/WRITE RANGE IN AIR (AT 25°C)	IQH-18GM-V1 0-46 mm	IQH-FP-V1 0-79 mm	IQH-F100-V1 0-300 mm
READ/WRITE RANGE ON STEEL (AT 25°C)	IQH-18GM-V1 -	IQH-FP-V1 -	IQH-F100-V1 -
PROTECTION (IEC)	IP67		IP20
TEMPERATURE RANGE	Working: -13°F to +158°F (-25°C to +70°C) Storage: -13°F to +185°F (-25°C to +85°C)	Working: -13°F to +122°F (-25°C to +50°C) Storage: -13°F to +122°F (-25°C to +50°C)	Working: -13°F to +158°F (-25°C to +70°C) Storage: -13°F to +185°F (-25°C to +85°C)
HOUSING MATERIAL	PET	PVC	ABS
MOUNTING CONSIDERATIONS	-	-	2 x #8 pan head max 4-8 in-lb torque

## Dimensions (mm)

IQC22-C5

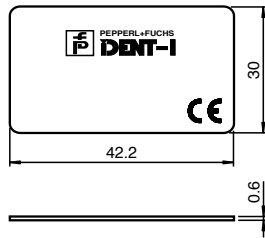

IQC22-C1

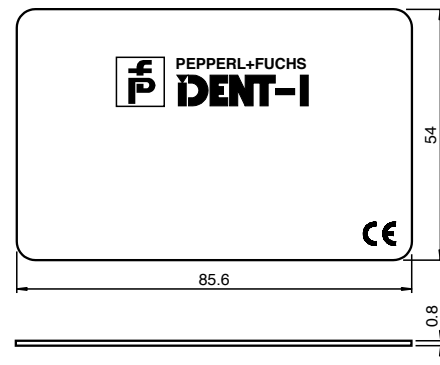

IQC22-C4

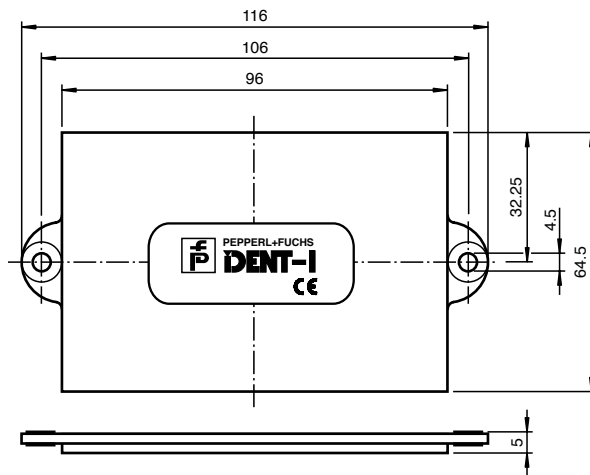

## Accessories

### Mounting Brackets

Model	Description
AB-18	Adjustable right angle bracket with 18GM read head
BF18	Adjustable bracket for 18GM read head
BF5-30	2 axes, adjustable bracket for cylindrical heads
RAM-2461-Y906430	Mounting plate for FP read heads
RAM-101U	Adjustable RAM mounting arm
RAM-200-1	Adjustable RAM mount with ½"NPT entrance

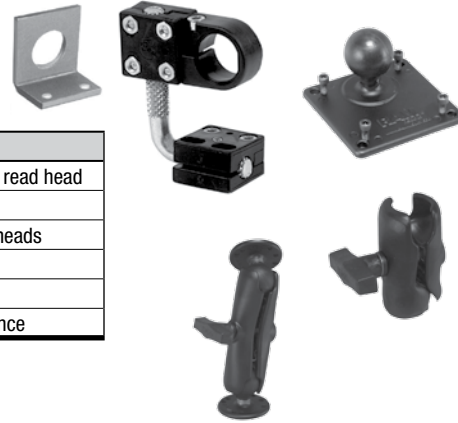

### Read Head Cables

Model	Description
V1-G-.6M-PUR ABG-V1-W	Length .6 m
V1-G-5M-PUR ABG-V1-W	Length 5 m
V1-G-10M-PUR ABG-V1-W	Length 10 m
V1-G-20M-PUR ABG-V1-W	Length 20 m



See pages 83-96 for complete RFID accessory listing.



# IDENT Control Series P Read Heads and Tags

- Read only, read/write and WORM tag options
- 6 read/write head choices for easy mounting
- Largest selection of tags from 12 mm to 100 mm diameter
- High- and extended-temperature tags available

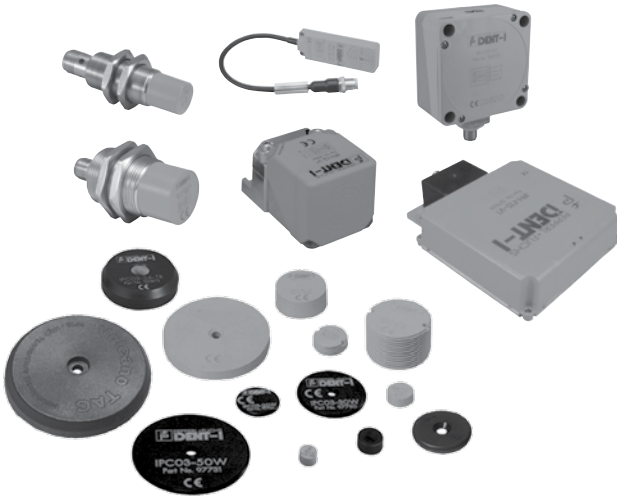

Series P is P+F's most versatile system, designed for use in factory automation applications. Tags can be embedded flush in any metal, and are available in a variety of housings. Our economical, heavy-duty commercial tags withstand high temperatures and washdown environments, and are available at prices that are comparable to light-duty non-housed tags.

### High Temperature



Many industrial applications have high- or extended-temperature applications. The Volcano tag is effective at temperatures exceeding 350 °F and other extended temperature tags withstand 250 °F and 300 °F environments.

### Low Frequency and Long Range

Series P includes a 100 mm diameter tag. Combining this tag with the F15 large reader will give you the largest, low frequency read range of over 6". These ranges are available when the tag is mounted to a nonmetallic surface or with a spacer.

## Common Specifications

### Series P Read Heads

LED FUNCTIONALITY	Green power, amber tag read	
OPERATING VOLTAGE	20-30 VDC from IDENT Control	
TEMPERATURE RANGE	Working	-13°F to +158°F (-25°C to +70°C)
	Storage	-13°F to +185°F (-25°C to +85°C)
APPROVALS	 	

### Series P Tags

OPERATING FREQUENCY	125 kHz
DATA TRANSFER RATE	2 kbit/s

### FRAM

The Ferroelectric RAM tag is unique to Series P. This type of memory allows an unlimited number of write operations. This tag also has a large memory capacity of 64 kbits, and is housed in a 58 mm diameter housing for direct mounting on any surface including metal.

### Memory Segmentation

All Series P tags have 32 bit memory blocks. Tags that are not FRAM have a 100,000 write limit. This memory segmentation is significant. If you switch to the next memory cell after the write limit is reached you get 100,000 more writes. The IPC03 tags have a write capacity of 2,900,000 if every cell on the tag is used.

### IPC02 Read Only Tags

These tags have a 40 bit read only code in ROM that is guaranteed to be unique. They are among the least expensive tags on the market. All tags come preprogrammed with data that cannot be changed by the user.

### WORM Tags

Write Once Read Many tags are unique in that they have 40 bits of read/write memory that can emulate a read only IPC02 tag. As an IPC02 they can never be written again and have the same fast read speed. If left in the IPC11 mode, they are a high-speed, 5-byte read/write tag.





## Series P Read Heads

HOUSING STYLE	18 mm	30 mm	F61	Compact Limit Switch	Flat Pack	F15	
MODEL	IPH-18GM-V1	IPH-30GM-V1	IPH-F61-V1	IPH-L2-V1	IPH-FP-V1	IPH-F15-V1	
MOUNTING	<i>Min. distance between heads, multiplex OFF</i>	180 mm	270 mm	290 mm	450 mm	550 mm	1100 mm
	<i>Min. distance between heads, multiplex ON</i>	30 mm	50 mm	50 mm	60 mm	100 mm	180 mm
POWER CONSUMPTION	1.2 W						
PROTECTION (IEC)	IP67						
HOUSING MATERIAL	PBT/stainless steel		ABS	PA-GF35	PBT/aluminum	PBT/stainless steel/aluminum	
WEIGHT	1.4 oz	2.6 oz	1.8 oz	7.5 oz	13.4 oz	42.1 oz	
ELECTRICAL CONNECTION	4-pin male M12 quick disconnect	4-pin male M12 quick disconnect	200 mm pigtail, 4-pin male M12 quick disconnect	4-pin male M12 quick disconnect	4-pin male M12 quick disconnect	4-pin male M12 quick disconnect	

IDENT Control Series P

## Dimensions (mm)

IPH-18GM-V1

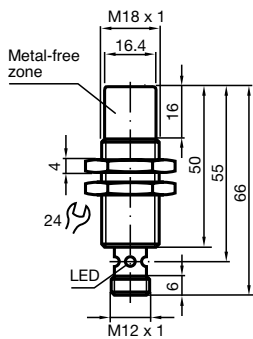

IPH-30GM-V1

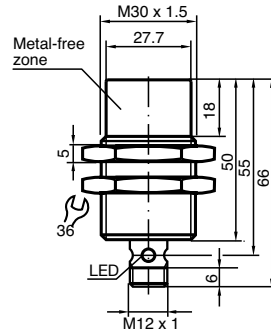

IPH-F61-V1

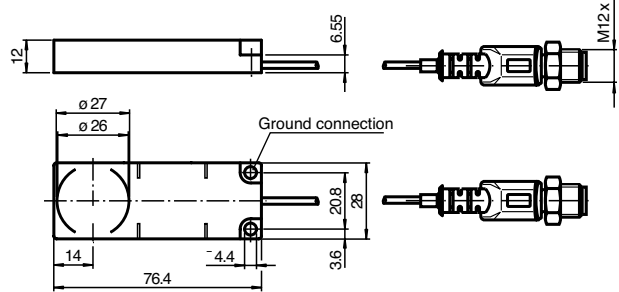

IPH-L2-V1

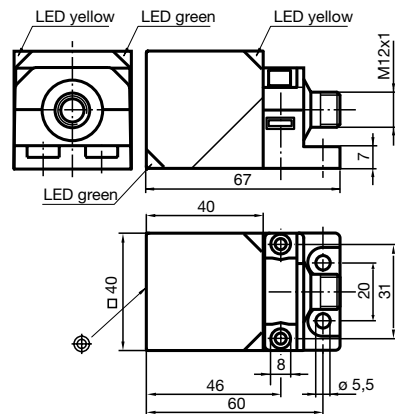

IPH-FP-V1

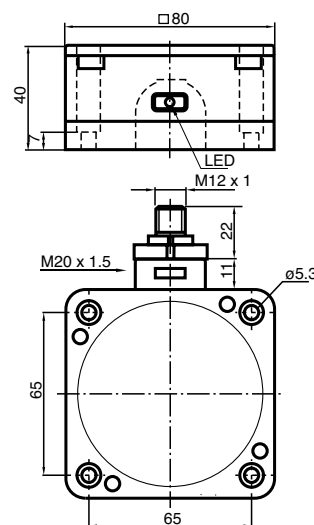

IPH-F15-V1

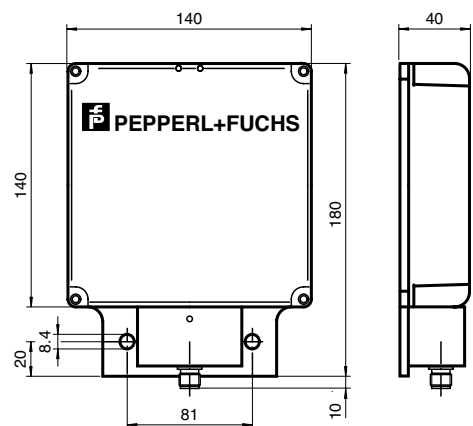



## Series P Tags

TYPE		Read Only			
MODEL		IPC02-12	IPC02-16	IPC02-20CD	IPC02-20W
ISO STANDARD/CHIP TYPE		EM4102			
READ SPEED		40 ms			
READ ONLY MEMORY		5 byte ROM			
DATA RETENTION		for the life of the tag			
READ/WRITE RANGE IN AIR (AT 25°C)	IPH-18GM-V1	0-14 mm		2-31 mm	
	IPH-30GM-V1	0-18 mm		3-42 mm	
	IPH-F61-V1	0-18 mm		3-42 mm	
	IPH-L2-V1	0-18 mm		1-48 mm	
	IPH-FP-V1	-		1-58 mm	
	IPH-F15-V1	-		-	
READ/WRITE RANGE IN AIR 7 MM SPACER TO STEEL (AT 25°C)	IPH-18GM-V1	0-9 mm		0-27 mm	
	IPH-30GM-V1	0-12 mm		1-35 mm	
	IPH-F61-V1	0-12 mm		1-35 mm	
	IPH-L2-V1	0-12 mm		2-38 mm	
	IPH-FP-V1	-		0-44 mm	
	IPH-F15-V1	-		-	
PROTECTION (IEC)		IP69k		IP67	
TEMPERATURE RANGE	Working	-13°F to +185°F (-25°C to +85°C)	-13°F to +185°F (-25°C to +85°C)	-4°F to +140°F (-20°C to +60°C)	-13°F to +158°F (-25°C to +70°C)
	Storage	-13°F to +266°F (-25°C to +130°C)	-13°F to +302°F (-25°C to +150°C)	-4°F to +140°F (-20°C to +60°C)	-40°F to +194°F (-40°C to +90°C)
HOUSING MATERIAL		Epoxy		PE/PES	PC

## Dimensions (mm)

IPC02-12

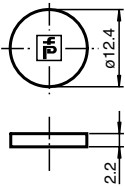

IPC02-16

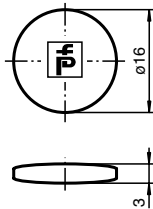

IPC02-20CD

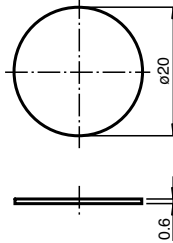

IPC02-20W

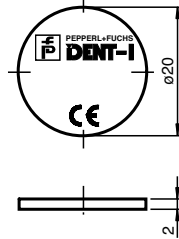



## Series P Tags

TYPE	Read Only (Continued)			
MODEL	IPC02-30W	IPC02-50W	IPC02-68-T7	IPC02-C1
ISO STANDARD/CHIP TYPE	EM4102			
READ SPEED	40 ms			
READ ONLY MEMORY	5 byte ROM			
DATA RETENTION	for the life of the tag			
READ/WRITE RANGE IN AIR (AT 25°C)	IPH-18GM-V1	2-40 mm		0-53 mm
	IPH-30GM-V1	3-55 mm		0-73 mm
	IPH-F61-V1	3-55 mm		0-73 mm
	IPH-L2-V1	3-64 mm		3-85 mm
	IPH-FP-V1	3-77 mm		2-98 mm
	IPH-F15-V1	-		0-108 mm
READ/WRITE RANGE IN AIR 7 MM SPACER TO STEEL (AT 25°C)	IPH-18GM-V1	1-35 mm		2-41 mm
	IPH-30GM-V1	2-47 mm		4-57 mm
	IPH-F61-V1	2-47 mm		4-57 mm
	IPH-L2-V1	3-52 mm		4-64 mm
	IPH-FP-V1	1-60 mm		1-78 mm
	IPH-F15-V1	-		0-83 mm
PROTECTION (IEC)	IP67			
TEMPERATURE RANGE	Working	-13°F to +158°F (-25°C to +70°C)		-40°F to +350°F (-40°C to +177°C) +32°F to +122°F (0°C to +50°C)
	Storage	-40°F to +194°F (-40°C to +90°C)		-40°F to +350°F (-40°C to +177°C) -40°F to +158°F (-40°C to +70°C)
HOUSING MATERIAL	PC		LCP	PVC
MOUNTING CONSIDERATIONS	#4 pan head max 4-6 in-lb torque	#6 pan head max 4-6 in-lb torque	#10 pan head max 4-6 in-lb torque	-

IDENT Control Series P

## Dimensions (mm)

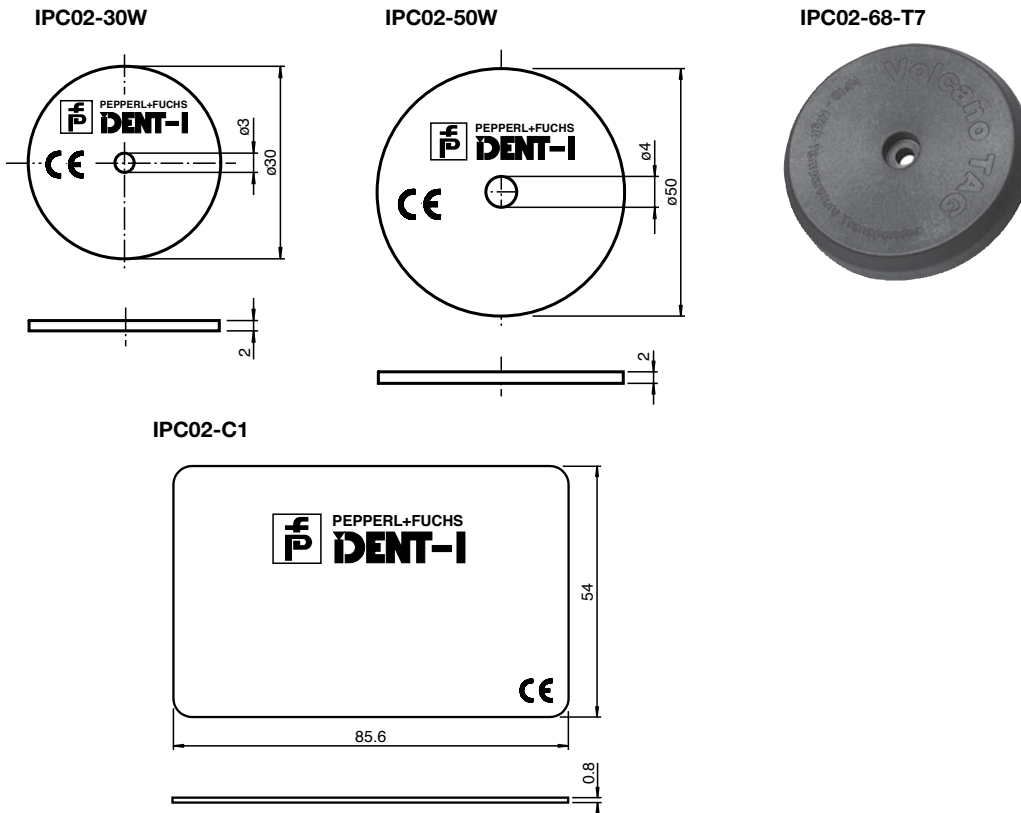



## Series P Tags

TYPE	WORM or Read/Write		
MODEL	IPC11-12	IPC11-30	IPC11-50
ISO STANDARD/CHIP TYPE	Q5, emulates EM4102		
READ SPEED	40 ms		
WRITE SPEED	130 ms		
READ/WRITE MEMORY	5 byte EEPROM		
WRITE CYCLES	1 WORM, > 100,000 read/write		
DATA RETENTION	10 years at 55°C		
READ/WRITE RANGE IN AIR (AT 25°C)			
<i>IPH-18GM-V1</i>	0-14 mm / 0-12 mm	0-38 mm / 0-27 mm	0-50 mm / 1-41 mm
<i>IPH-30GM-V1</i>	0-18 mm / 0-15 mm	1-52 mm / 1-37 mm	0-66 mm / 1-43 mm
<i>IPH-F61-V1</i>	0-18 mm / 0-15 mm	1-52 mm / 1-37 mm	0-66 mm / 1-43 mm
<i>IPH-L2-V1</i>	0-18 mm / 0-15 mm	2-60 mm / 2-42 mm	0-79 mm / 0-50 mm
<i>IPH-FP-V1</i>	-	0-75 mm / 1-53 mm	2-98 mm / 0-70 mm
<i>IPH-F15-V1</i>	-	-	0-100 mm / 0-80 mm
READ/WRITE RANGE IN AIR 7 MM SPACER TO STEEL (AT 25°C)			
<i>IPH-18GM-V1</i>	0-9 mm / 0-7 mm	1-34 mm / 1-25 mm	2-37 mm / 0-36 mm
<i>IPH-30GM-V1</i>	0-12 mm / 0-9 mm	1-44 mm / 1-33 mm	2-53 mm / 1-41 mm
<i>IPH-F61-V1</i>	0-12 mm / 0-9 mm	1-44 mm / 1-33 mm	2-53 mm / 1-41 mm
<i>IPH-L2-V1</i>	0-12 mm / 0-9 mm	2-50 mm / 2-36 mm	2-59 mm / 2-48 mm
<i>IPH-FP-V1</i>	-	0-59 mm / 1-41 mm	1-72 mm / 0-68 mm
<i>IPH-F15-V1</i>	-	-	1-83 mm / 2-69 mm
PROTECTION (IEC)	IP69k		IP67
TEMPERATURE RANGE			
<i>Working</i>	-13°F to +185°F (-25°C to +85°C)	-13°F to +158°F (-25°C to +70°C)	
<i>Storage</i>	-40°F to +266°F (-40°C to +130°C)	-40°F to +194°F (-40°C to +90°C)	
HOUSING MATERIAL	PPS, epoxy		PC
MOUNTING CONSIDERATIONS	-	#4 pan head max 4-6 in-lb torque	#6 pan head max 4-6 in-lb torque

## Dimensions (mm)

IPC11-12

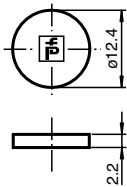

IPC11-30

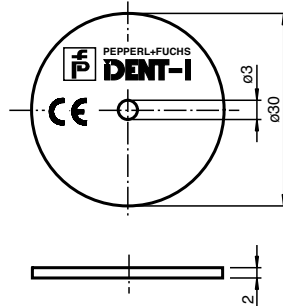

IPC11-50

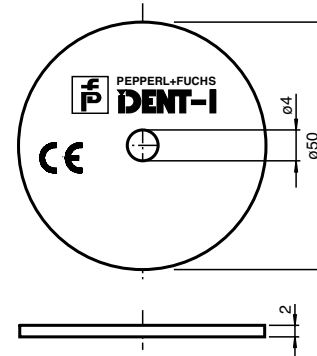



## Series P Tags

TYPE	Read/Write		
MODEL	IPC03-20K1	IPC03-20W	IPC03-30W
ISO STANDARD/CHIP TYPE	EM4450		
READ SPEED	100 ms + (30 ms each 4 byte word)		
WRITE SPEED	100 ms + (100 ms each 4 byte word)		
READ/WRITE MEMORY	116 byte EEPROM		
READ ONLY MEMORY	4 byte ROM		
WRITE CYCLES	> 100,000 per word		
DATA RETENTION	10 years at 55°C		
READ/WRITE RANGE IN AIR (AT 25°C)	IPH-18GM-V1	0-31 mm / 0-20 mm	0-38 mm / 0-27 mm
	IPH-30GM-V1	1-40 mm / 0-27 mm	1-45 mm / 1-38 mm
	IPH-F61-V1	1-40 mm / 0-27 mm	1-45 mm / 1-38 mm
	IPH-L2-V1	2-48 mm / 0-30 mm	2-60 mm / 2-42 mm
	IPH-FP-V1	1-58 mm / 0-34 mm	0-75 mm / 1-53 mm
	IPH-F15-V1	-	-
READ/WRITE RANGE IN AIR 7 MM SPACER TO STEEL (AT 25°C)	IPH-18GM-V1	0-27 mm / 0-18 mm	1-34 mm / 1-25 mm
	IPH-30GM-V1	1-35 mm / 0-24 mm	1-44 mm / 1-33 mm
	IPH-F61-V1	1-35 mm / 0-24 mm	1-44 mm / 1-33 mm
	IPH-L2-V1	1-39 mm / 1-25 mm	2-50 mm / 2-37 mm
	IPH-FP-V1	0-44 mm / 0-22 mm	0-59 mm / 1-41 mm
	IPH-F15-V1	-	-
PROTECTION (IEC)	IP67		
TEMPERATURE RANGE	Working	-13°F to +158°F (-25°C to +70°C)	
	Storage	-40°F to +194°F (-40°C to +90°C)	
HOUSING MATERIAL	PC		
MOUNTING CONSIDERATIONS	-		#4 pan head max 4-6 in-lb torque

## Dimensions (mm)

IPC03-20K1

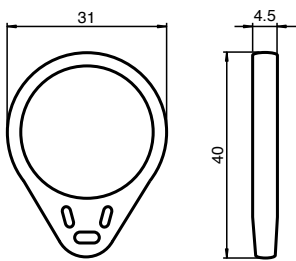

IPC03-20W

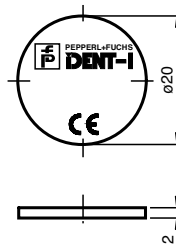

IPC03-30W

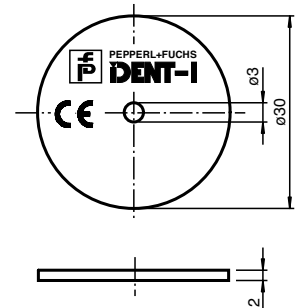



## Series P Tags

TYPE	Read/Write (Continued)		
MODEL	IPC03-50P	IPC03-C1	IPC03-100
ISO STANDARD/CHIP TYPE	EM4450		
READ SPEED	100 ms + (30 ms each 4 byte word)		
WRITE SPEED	100 ms + (100 ms each 4 byte word)		
READ/WRITE MEMORY	116 byte EEPROM		
READ ONLY MEMORY	4 byte ROM		
WRITE CYCLES	> 100,000 per word		
DATA RETENTION	10 years at 55°C		
READ/WRITE RANGE IN AIR (AT 25°C)			
IPH-18GM-V1	1-50 mm / 1-41 mm		-
IPH-30GM-V1	1-69 mm / 1-50 mm		-
IPH-F61-V1	2-75 mm / 2-64 mm		
IPH-L2-V1	1-80 mm / 2-65 mm		-
IPH-FP-V1	0-101 mm / 0-84 mm		-
IPH-F15-V1	2-111 mm / 2-107 mm		2-157 mm / 2-143 mm
READ/WRITE RANGE IN AIR 7 MM SPACER TO STEEL (AT 25°C)			
IPH-18GM-V1	0-39 mm / 0-36 mm		-
IPH-30GM-V1	1-56 mm / 1-46 mm		-
IPH-F61-V1	2-62 mm / 2-54 mm		
IPH-L2-V1	1-64 mm / 1-57 mm		-
IPH-FP-V1	0-76 mm / 0-70 mm		-
IPH-F15-V1	1-83 mm / 2-69 mm		3-90 mm / 3-80 mm
PROTECTION (IEC)	IP67		
TEMPERATURE RANGE			
Working	-40°F to +158°F (-40°C to +70°C)	+32°F to +122°F (0°C to +50°C)	-40°F to +185°F (-40°C to +85°C)
Storage	-40°F to +194°F (-40°C to +90°C)	-40°F to +158°F (-40°C to +70°C)	-67°F to +194°F (-55°C to +90°C)
HOUSING MATERIAL	PC, epoxy	PVC	Epoxy
MOUNTING CONSIDERATIONS	#6 flat head max 4-8 in-lb torque	-	#10 pan head max 4-8 in-lb torque

## Dimensions (mm)

IPC03-50P

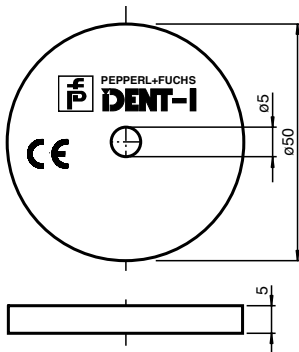

IPC03-C1

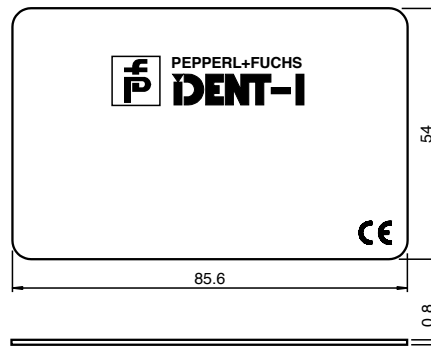

IPC03-100

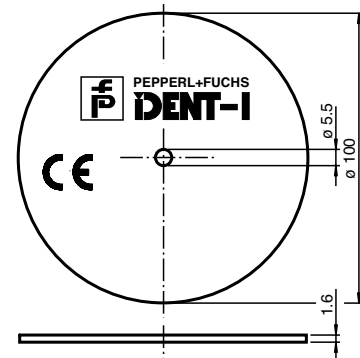



IDENT Control Series P

## Series P Tags

TYPE	Read/Write Embeddable			
MODEL	IPC03-12.4	IPC03-16GK	IPC03-24	IPC03-30GK
ISO STANDARD/CHIP TYPE	EM4450			
READ SPEED	100 ms + (30 ms each 4 byte word)			
WRITE SPEED	100 ms + (100 ms each 4 byte word)			
READ/WRITE MEMORY	116 byte EEPROM			
READ ONLY MEMORY	4 byte ROM			
WRITE CYCLES	> 100,000 per word			
DATA RETENTION	10 years at 55°C			
READ/WRITE RANGE FLUSH IN STEEL (AT 25°C)	IPH-18GM-V1	0-14 mm / 0-10 mm	0-14 mm / 0-10 mm	0-16 mm / 0-11 mm
	IPH-30GM-V1	0-17 mm / 1-12 mm	0-17 mm / 0-12 mm	1-22 mm / 1-22 mm
	IPH-F61-V1	0-17 mm / 1-12 mm	0-17 mm / 0-12 mm	1-22 mm / 1-22 mm
	IPH-L2-V1	4-16 mm / 4-6 mm	–	1-21 mm / 1-16 mm
READ/WRITE RANGE FLUSH IN ALUMINUM (AT 25°C)	IPH-18GM-V1	0-10 mm / 0-8 mm	0-13 mm / 0-9 mm	1-19 mm / 0-15 mm
	IPH-30GM-V1	1-12 mm / 1-6 mm	0-15 mm / 0-10 mm	1-24 mm / 1-16 mm
	IPH-F61-V1	1-12 mm / 1-6 mm	0-15 mm / 0-10 mm	1-24 mm / 1-16 mm
	IPH-L2-V1	–	–	–
PROTECTION (IEC)	IP67			
TEMPERATURE RANGE	Working	-13°F to +158°F (-25°C to +70°C)		
	Storage	-40°F to +185°F (-40°C to +85°C)		
HOUSING MATERIAL	PBT			
MOUNTING CONSIDERATIONS	–	M16 x 1 threaded hole	–	M30 x 1.5 threaded hole

## Dimensions (mm)

IPC03-12.4

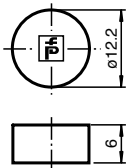

IPC03-16GK

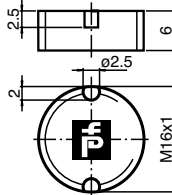

IPC03-24

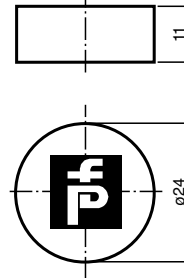

IPC03-30GK

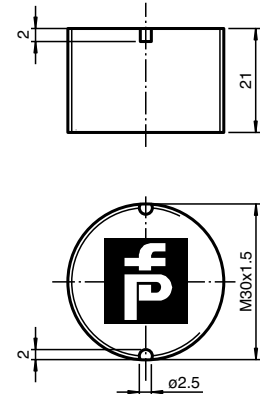



## Series P Tags

TYPE	Read/Write Surface Mount			
MODEL	IPC03-20CT	IPC03-54-T8	IPC03-58	IPC12-58-64K
ISO STANDARD/CHIP TYPE	EM4450			-
READ SPEED	100 ms + (30 ms each 4 byte word)			
WRITE SPEED	100 ms + (100 ms each 4 byte word)			
READ/WRITE MEMORY	116 byte EEPROM			8192 byte FRAM
READ ONLY MEMORY	4 byte ROM			
WRITE CYCLES	> 100,000 per word			unlimited
DATA RETENTION	10 years at 55°C			
READ/WRITE RANGE IN AIR (AT 25°C)	IPH-18GM-V1	0-29 mm / 0-18 mm	0-50 mm / 0-41 mm	0-25 mm / 0-20 mm
	IPH-30GM-V1/ IPH-F61-V1	0-39 mm / 0-26 mm	0-70 mm / 0-55 mm	0-35 mm / 0-27 mm
	IPH-L2-V1	0-47 mm / 0-29 mm	0-77 mm / 0-65 mm	0-38 mm / 0-32 mm
	IPH-FP-V1	0-56 mm / 0-33 mm	3-106 mm / 2-92 mm	0-53 mm / 0-47 mm
	IPH-F15-V1	-	0-111 mm / 0-107 mm	0-55 mm / 0-53 mm
READ/WRITE RANGE ON STEEL (AT 25°C)	IPH-18GM-V1	0-29 mm / 0-18 mm	0-44 mm / 0-38 mm	0-22 mm / 0-19 mm
	IPH-30GM-V1/ IPH-F61-V1	0-39 mm / 0-26 mm	1-60 mm / 1-50 mm	0-30 mm / 0-25 mm
	IPH-L2-V1	0-47 mm / 0-29 mm	2-67 mm / 2-60 mm	0-33 mm / 0-30 mm
	IPH-FP-V1	0-56 mm / 0-33 mm	0-85 mm / 0-76 mm	0-42 mm / 0-38 mm
	IPH-F15-V1	-	0-83 mm / 0-69 mm	0-41 mm / 0-34 mm
PROTECTION (IEC)	IP68	IP67	IP68	IP65
TEMPERATURE RANGE	Working	-13°F to +158°F (-25°C to +70°C)	-40°F to +248°F (-40°C to +120°C)	-13°F to +185°F (-25°C to +85°C)
	Storage	-40°F to +194°F (-40°C to +90°C)	-40°F to +248°F (-40°C to +120°C)	-13°F to +185°F (-25°C to +85°C)
HOUSING MATERIAL	Nylotron	PUR	PUR	PUR
MOUNTING CONSIDERATIONS	#10 pan head max 10-20 in-lb torque	#10 flat head max 4-6 in-lb torque	#10 flat head max 10-20 in-lb torque	#10 flat head max 10-20 in-lb torque

## Dimensions (mm)

IPC03-20CT

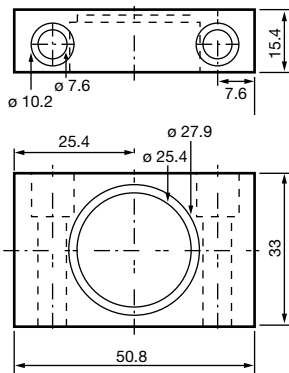

IPC03-54-T8

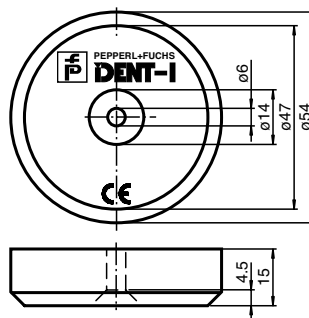

IPC03-58  
IPC12-58-64K

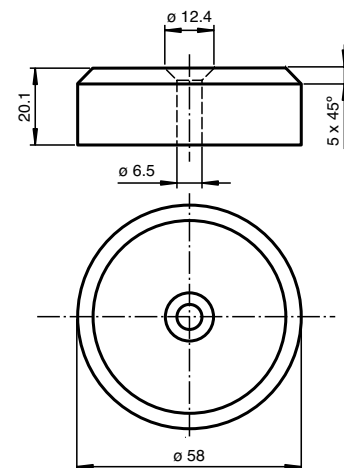



## Accessories

### Mounting Brackets

Model	Description
AB-18	Adjustable right angle bracket with 18GM read head
AB-30	Adjustable right angle bracket with 30GM read head
BF18	Adjustable bracket for 18GM read head
BF30	Adjustable bracket for 30GM read head
BF5-30	2 axes, adjustable bracket for cylindrical heads
RAM-2461-Y906430	Mounting plate for FP read heads
RAM-101U	Adjustable RAM mounting arm
RAM-200-1	Adjustable RAM mount with ½"NPT entrance

### Read Head Cables

Model	Description
V1-G-.6M-PUR ABG-V1-W	Length .6 m
V1-G-5M-PUR ABG-V1-W	Length 5 m
V1-G-10M-PUR ABG-V1-W	Length 10 m
V1-G-20M-PUR ABG-V1-W	Length 20 m

### Tag Mounting Accessories And Covers

Model	Description
IVZ-16GK-EW	Mounting tool for 16GK tags
IVZ-30G-EW	Mounting tool for 30GK tags
ICS-30GK	Delrin cover for 30GK tags
IPZ-MH50	7 mm spacer, 50 mm diameter



See pages 83-96 for complete RFID accessory listing.

## IDENT Control Series S Read Heads and Tags

- Smallest embeddable tag 8 mm and 10 mm diameter
- Fastest tag read available by any company
- Reads/writes same tags as IDENT I System V
- Embeddable high-temperature tags



Series S is specifically designed for industrial applications. The new high-speed read heads for IDC and ICC tags are a perfect fit for line expansions and high-speed applications. The embeddable tags are often used for high-temperature applications in foundries and other processing facilities.

### Legacy Systems

P+F's first RFID system, which is still available, was IDENT I System V. This system has sold more tags than any of the other systems combined. Series S read heads are designed to use the same tags. Series S also offers many new and advanced features including, higher baud rates, faster read speeds, simultaneous running read heads, cast aluminum housing, special high-speed codes, and a new 32-bit ROM for IDCs.

### High-Speed Reading

The IDC tags can be programmed with a special high-speed code. This special 24-bit code reads in 5 ms. This is the fastest read operation that P+F currently offers. It is perfect for high-speed crane positioning applications or any situation requiring high passing speeds.

## Common Specifications

### Series S Read Heads

LED FUNCTIONALITY	Green power, amber tag read	
OPERATING VOLTAGE	From IDENT Control	
TEMPERATURE RANGE	<i>Working</i>	-13°F to +158°F (-25°C to +70°C)
	<i>Storage</i>	-13°F to +185°F (-25°C to +85°C)
APPROVALS	CE 	

### Series S Tags

OPERATING FREQUENCY	250 kHz
DATA TRANSFER RATE	20 kbit/s

### Small Tags



Most Series S tags are embeddable. Because of their special design, they can be flush-mounted in steel or aluminum with little range reduction. Also, this is the only system that has 8 mm and 10 mm tags, which are a standard for machine tool applications.

### Temperature

The ICC tags are embeddable in metal and perfect for high temperature applications. The threaded housings are easily installed with the 30 mm mounting tool. Teflon caps are available to resist weld slag buildup and to protect the face from wear.



## Series S Read Heads

HOUSING STYLE	18 mm	F61	Flat Pack
MODEL	ISH-18GM-V1	ISH-F61-V1	ISH-FP-V1
MOUNTING	<i>Min. distance between heads, multiplex OFF</i>	350 mm	810 mm
	<i>Min. distance between heads, multiplex ON</i>	155 mm	225 mm
POWER CONSUMPTION		1.8 W	
PROTECTION (IEC)		IP67	
HOUSING MATERIAL	PBT/stainless steel	ABS	PBT/aluminum
WEIGHT	1.4 oz	1.8 oz	13.4 oz
ELECTRICAL CONNECTION	 4-pin male M12 quick disconnect	 200 mm pigtail, 4-pin male M12 quick disconnect	 4-pin male M12 quick disconnect

## Dimensions (mm)

ISH-18GM-V1

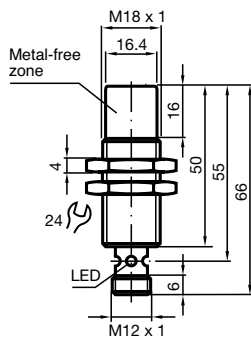

ISH-F61-V1

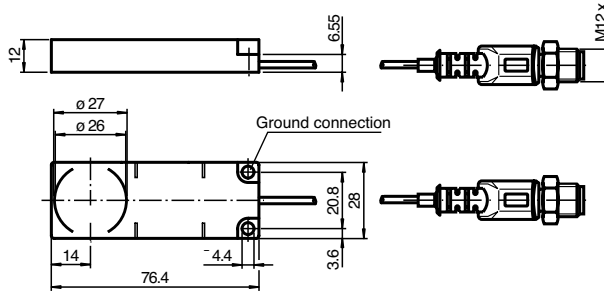

ISH-FP-V1

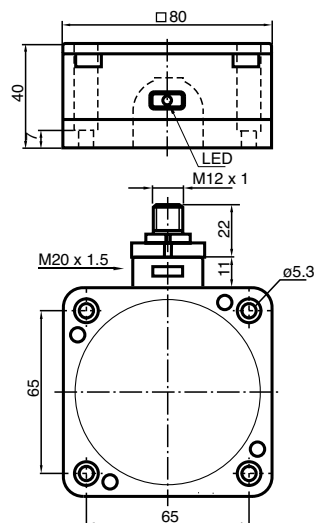



## Series S Tags

TYPE		Read Only			
MODEL		ICC-8A	ICC-12A	ICC-12A-T1	ICC-16GKA
ISO STANDARD/CHIP TYPE		-			
READ SPEED		7 ms			
READ ONLY MEMORY		7 byte ROM			
DATA RETENTION		unlimited			
READ/WRITE RANGE IN AIR (AT 25°C)	ISH-18GM-V1	0.3-12.5 mm	0.3-14 mm	0.5-13 mm	0.3-14 mm
	ISH-F61-V1	0.5-15 mm	0.3-19 mm	0.5-18 mm	0.3-19 mm
	ISH-FP-V1	-	-	-	-
READ/WRITE RANGE FLUSH IN STEEL (AT 25°C)	ISH-18GM-V1	1-10.4 mm	0.5-13 mm	1-12 mm	1-12 mm
	ISH-F61-V1	2-6.5 mm	1-12 mm	1-11 mm	1-12 mm
	ISH-FP-V1	-	-	-	-
PROTECTION (IEC)		IP67			
TEMPERATURE RANGE	Working	-13°F to +158°F (-25°C to +70°C)		-13°F to +266°F (-25°C to +130°C)	-13°F to +158°F (-25°C to +70°C)
	Storage	-40°F to +185°F (-40°C to +85°C)		-13°F to +302°F (-40°C to +150°C)	-40°F to +185°F (-40°C to +85°C)
HOUSING MATERIAL		PBT	Epoxy	Ryton R4	PBT
MOUNTING CONSIDERATIONS		-			M16 x 1 threaded hole

## Dimensions (mm)

ICC-8A

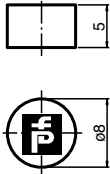

ICC-12A

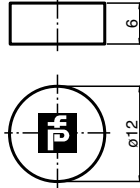

ICC-12A-T1

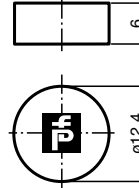

ICC-16GKA

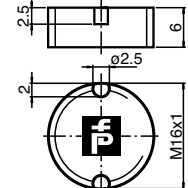



## Series S Tags

TYPE	Read Only (Continued)			
MODEL	ICC-30GKA-T1	ICC-30GKA-T3	ICC-50A	
ISO STANDARD/CHIP TYPE	-			
READ SPEED	7 ms			
READ ONLY MEMORY	7 byte ROM			
DATA RETENTION	unlimited			
READ/WRITE RANGE IN AIR (AT 25°C)	ISH-18GM-V1	2-32 mm	1-42 mm	
	ISH-F61-V1	2-41 mm	2-66 mm	
	ISH-FP-V1	1-58 mm	10-100 mm	
READ/WRITE RANGE FLUSH IN STEEL (AT 25°C)	ISH-18GM-V1	4-24 mm	-	
	ISH-F61-V1	2-26 mm	-	
	ISH-FP-V1	-	-	
PROTECTION (IEC)	IP67	IP68	IP67	
TEMPERATURE RANGE	Working	-13°F to +266°F (-25°C to +130°C)	-13°F to +230°F (-25°C to +110°C)	-13°F to +158°F (-25°C to +70°C)
	Storage	-40°F to +302°F (-40°C to +150°C)	-40°F to +230°F (-40°C to +110°C)	-40°F to +185°F (-40°C to +85°C)
HOUSING MATERIAL	PA	PP	PBT	
MOUNTING CONSIDERATIONS	M30 x 1.5 thread hole	M30 x 1.5 thread hole	#6 flat head max 4-8 in-lb torque	

## Dimensions (mm)

ICC-30GKA-T1  
ICC-30GKA-T3

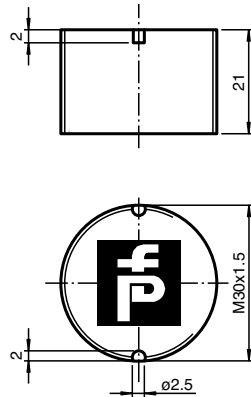

ICC-50A

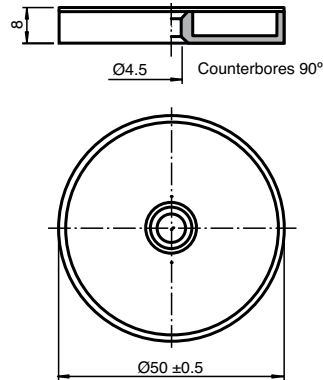



## Series S Tags

TYPE	Read/Write			
MODEL	IDC-8-1K	IDC-10-1K	IDC-12-1K	IDC-15-1K
ISO STANDARD/CHIP TYPE	-			
READ SPEED	13 ms each 4 byte word, 5 ms special high-speed code, 13 ms read only code			
WRITE SPEED	50 ms + (50 ms each 4 byte word)			
READ/WRITE MEMORY	128 byte EEPROM, 24 bit special high-speed code			
READ ONLY MEMORY	4 byte ROM			
WRITE CYCLES	> 500,000			
DATA RETENTION	18 years at 50°C			
READ/WRITE RANGE IN AIR (AT 25°C)	ISH-18GM-V1	2-12.5 mm / 2-8.5 mm	2-16 mm / 2-12 mm	3-19 mm / 3-17 mm
	ISH-F61-V1	3-9 mm / 3-9 mm	3-15 mm / 3-15 mm	5-18 mm / 5-18 mm
	ISH-FP-V1			5-30 mm / 5-20 mm
READ/WRITE RANGE FLUSH IN STEEL (AT 25°C)	ISH-18GM-V1	2-9 mm / 2-6 mm	2-11 mm / 2-9 mm	3-14 mm / 3-13 mm
	ISH-F61-V1	-	3-12 mm / 3-6 mm	5-18 mm / 5-12 mm
	ISH-FP-V1	-	-	-
READ/WRITE RANGE ON STEEL (AT 25°C)	ISH-18GM-V1	-	-	-
	ISH-F61-V1	-	-	-
	ISH-FP-V1	-	-	-
PROTECTION (IEC)	IP67			
TEMPERATURE RANGE	Working	-13°F to +158°F (-25°C to +70°C)		
	Storage	-40°F to +185°F (-40°C to +85°C)		
HOUSING MATERIAL	PBT		Epoxy	PBT

## Dimensions (mm)

IDC-8-1K

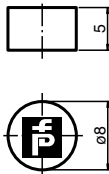

IDC-10-1K

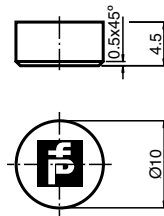

IDC-12-1K

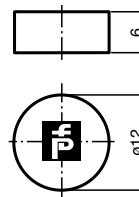

IDC-15-1K

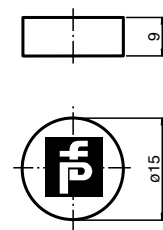



IDENT Control Series S

## Series S Tags

TYPE	Read/Write (Continued)			
MODEL	IDC-16GK-1K	IDC-24-1K	IDC-24-1K-Y94646	IDC-30GK-1K
ISO STANDARD/CHIP TYPE	-			
READ SPEED	13 ms each 4 byte word, 5 ms special high-speed code, 13 ms read only code			
WRITE SPEED	50 ms + (50 ms each 4 byte word)			
READ/WRITE MEMORY	128 byte EEPROM, 24 bit special high-speed code			
READ ONLY MEMORY	4 byte ROM			
WRITE CYCLES	> 500,000			
DATA RETENTION	18 years at 50°C			
READ/WRITE RANGE IN AIR (AT 25°C)	ISH-18GM-V1	2-16 mm / 2-12 mm	5-24 mm / 5-23 mm	5-27 mm / 5-25 mm
	ISH-F61-V1	3-15 mm / 3-15 mm	4-28 mm / 4-28 mm	5-30 mm / 5-30 mm
	ISH-FP-V1	-	5-47 mm / 5-43 mm	5-50 mm / 5-43 mm
READ/WRITE RANGE FLUSH IN STEEL (AT 25°C)	ISH-18GM-V1	2-11 mm / 2-9 mm	5-19 mm / 5-18 mm	5-21 mm / 5-19 mm
	ISH-F61-V1	3-12 mm / 3-6 mm	4-22 mm / 4-19 mm	5-25 mm / 5-20 mm
	ISH-FP-V1	-	-	-
READ/WRITE RANGE ON STEEL (AT 25°C)	ISH-18GM-V1	-	5-19 mm / 5-18 mm	-
	ISH-F61-V1	-	4-28 mm / 4-28 mm	-
	ISH-FP-V1	-	5-47 mm / 5-43 mm	-
PROTECTION (IEC)	IP67			
TEMPERATURE RANGE	Working	-13°F to +158°F (-25°C to +70°C)		
	Storage	-40°F to +185°F (-40°C to +85°C)		
HOUSING MATERIAL	PBT		Nylotron	PP
MOUNTING CONSIDERATIONS	M16 x 1 threaded hole	-	#10 pan head max 10-20 in-lb torque	M30 x 1.5 thread hole

## Dimensions (mm)

IDC-16GK-1K

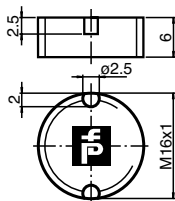

IDC-24-1K

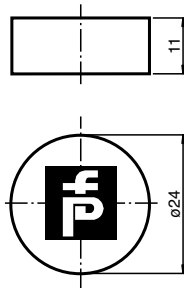

IDC-24-1K-Y94646

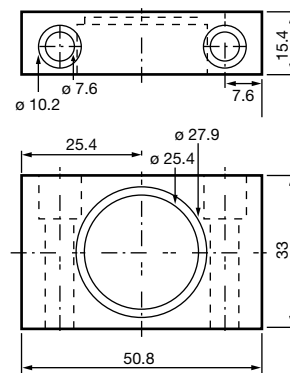

IDC-30GK-1K

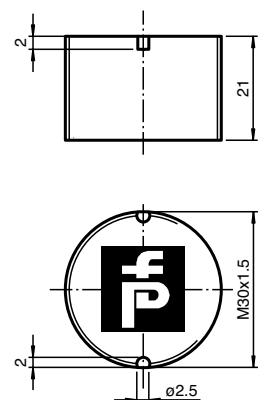

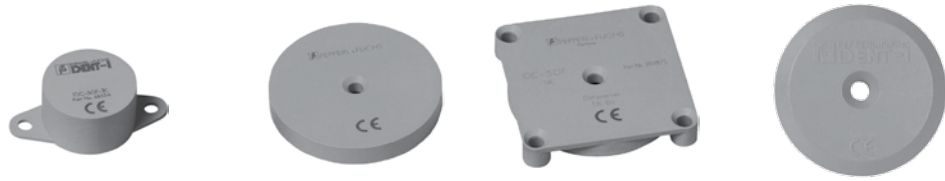

## Series S Tags

TYPE	Read/Write (Continued)			
MODEL	IDC-30F-1K	IDC-50-1K	IDC-50F-1K	IDC-58-1K
ISO STANDARD/CHIP TYPE	-			
READ SPEED	13 ms each 4 byte word, 5 ms special high-speed code, 13 ms read only code			
WRITE SPEED	50 ms + (50 ms each 4 byte word)			
READ/WRITE MEMORY	128 byte EEPROM, 24 bit special high-speed code			
READ ONLY MEMORY	4 byte ROM			
WRITE CYCLES	> 500,000			
DATA RETENTION	18 years at 50°C			
READ/WRITE RANGE IN AIR (AT 25°C)	ISH-18GM-V1: 5-27 mm / 5-25 mm ISH-F61-V1: 5-30 mm / 5-30 mm ISH-FP-V1: 5-50 mm / 5-43 mm	8-40 mm / 8-39 mm 10-42 mm / 10-42 mm 12-95 mm / 15-80 mm		-
READ/WRITE RANGE FLUSH IN STEEL (AT 25°C)	ISH-18GM-V1: 5-21 mm / 5-19 mm ISH-F61-V1: 5-25 mm / 5-20 mm ISH-FP-V1: -	-	-	-
READ/WRITE RANGE ON STEEL (AT 25°C)	ISH-18GM-V1: 5-27 mm / 5-25 mm ISH-F61-V1: 5-30 mm / 5-30 mm ISH-FP-V1: 5-50 mm / 5-43 mm	-	-	5-34 mm / 5-24 mm 7-42 mm / 7-31 mm 7-72 mm / 7-57 mm
PROTECTION (IEC)	IP67			IP68
TEMPERATURE RANGE	Working	-13°F to +158°F (-25°C to +70°C)		
	Storage	-40°F to +185°F (-40°C to +85°C)		
HOUSING MATERIAL	PBT			ABS
MOUNTING CONSIDERATIONS	#6 pan head max 4-8 in-lb torque	#6 flat head max 4-8 in-lb torque		#10 flat head max 10-20 in-lb torque

## Dimensions (mm)

IDC-30F-1K

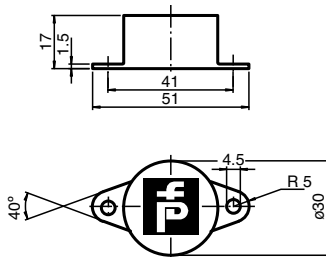

IDC-50-1K

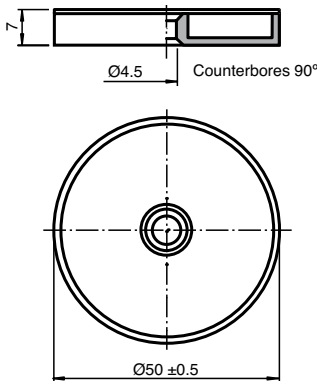

IDC-50F-1K

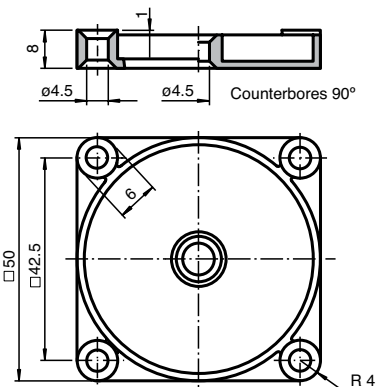

IDC-58-1K

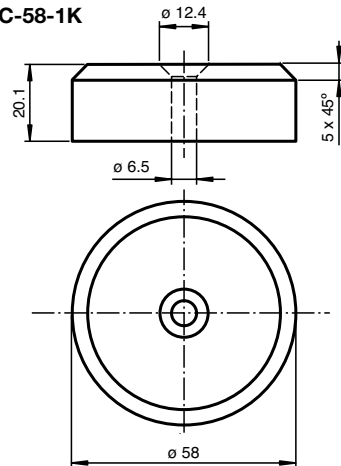



## Accessories

### Mounting Brackets

Model	Description
AB-18	Adjustable right angle bracket with 18GM read head
BF18	Adjustable bracket for 18GM read head
BF5-30	2 axes, adjustable bracket for cylindrical heads
RAM-2461-Y906430	Mounting Plate for FP read heads
RAM-101U	Adjustable RAM mounting arm
RAM-200-1	Adjustable RAM mount with 1/2"NPT entrance



### Read Head Cables

Model	Description
V1-G-.6M-PUR ABG-V1-W	Length .6 m
V1-G-5M-PUR ABG-V1-W	Length 5 m
V1-G-10M-PUR ABG-V1-W	Length 10 m
V1-G-20M-PUR ABG-V1-W	Length 20 m



### Tag Mounting Accessories And Covers

Model	Description
IVZ-16GK-EW	Mounting tool for 16GK tags
IVZ-30G-EW	Mounting tool for 30GK tags
ICS-30GK	Delrin cover for 30GK tags
IPZ-MH50	7 mm spacer, 50 mm diameter



See pages 83-96 for complete RFID accessory listing.

## IDENT Control Series MV Read Heads and Tags

- Long-range read and write to 4 m
- One tag and one head size
- High-speed reading and writing
- High-capacity tag with replaceable battery



Series MV is the longest-range system available for IDENT Control with ranges as far as 4 meters. The high-capacity tag is used in many automotive assembly applications because of its robustness and speed. After years of service, the battery can easily be replaced allowing unlimited tag life.

### Industrial Mounting

The 1/8" stainless steel mounting plate on the back of the read heads and the quick disconnect make configuration and setup versatile. No read head programming is required. There is no worry about steel surrounding the tag, because the MVC tag can be flush mounted in steel with little range reduction.

### Replaceable Battery



The read head can read the battery capacity at any time. When the battery is low, which could take up to 5 years, it can be exchanged easily. Two screws hold the battery cover in place on the back of the unit.

### High Data Capacity

Over 7000 bytes of data can be stored on this tag, making it one of the largest capacity tags that P+F has to offer. Because of the high frequency—2.45 GHz—and the battery pack, tag data reading and writing is very fast. Because the tag is limited only by the battery capacity, it can be read and written to an unlimited number of times.

## Common Specifications

### Series MV Read Heads

LED FUNCTIONALITY	Green power, amber tag read	
OPERATING VOLTAGE	From IDENT Control	
TEMPERATURE RANGE	Working	+25°F to +158°F (-4°C to +70°C)
	Storage	+25°F to +158°F (-4°C to +70°C)
APPROVALS	 	

### Series MV Tags

OPERATING FREQUENCY	2.45 GHz
DATA TRANSFER RATE	76.8 kbit/s

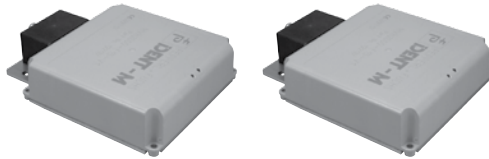

## Series MV Read Heads

HOUSING STYLE	F15	F15
MODEL	MVH500-F15-V1	MVH2000-F15-V1
MOUNTING	2000 mm	8000 mm
	Min. distance between heads, multiplex OFF	
	Min. distance between heads, multiplex ON	
POWER CONSUMPTION	7 W	
PROTECTION (IEC)	IP65	
HOUSING MATERIAL	PBT/stainless steel/aluminum	
WEIGHT	42.4 oz	
ELECTRICAL CONNECTION	 4-pin male M12 quick disconnect	

## Dimensions (mm)

MVH500-F15-V1  
MVH2000-F15-V1

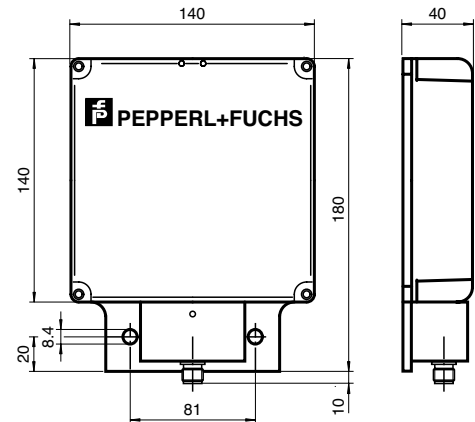

## Series MV Tag

TYPE	Read/Write	
MODEL	MVC-60B-64K	
ISO STANDARD/CHIP TYPE	-	
READ/WRITE MEMORY	59 k (7552 bytes)	
READ ONLY MEMORY	8 Byte serial number	
BATTERY LIFE	≈ 5 years without read or write operations or ≈ 15 mill. read operations on 64 bytes per access, battery is replaceable	
READ/WRITE RANGE IN AIR (AT 25°C)	MVH500-F15-V1	0-0.5 m, max 1.5 m
	MVH2000-F15-V1	0.2-2 m, max 4 m
READ/WRITE RANGE FLUSH IN STEEL (AT 25°C)	MVH500-F15-V1	0-0.5 m, max 1.5 m
	MVH2000-F15-V1	0.2-2 m, max 4 m
PROTECTION (IEC)	IP65	
TEMPERATURE RANGE	Working	+25°F to +158°F (-4°C to +70°C)
	Storage	+25°F to +158°F (-4°C to +70°C)
HOUSING MATERIAL	sPS and PBT	
MOUNTING CONSIDERATIONS	#8 pan head max 4-8 in-lb torque	

## Dimensions (mm)

MVC-60B-64K

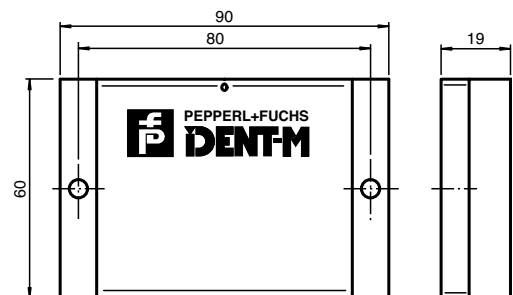

## Accessories

### Read Head Cables

Model	Description
V1-G-.6M-PUR ABG-V1-W	Length .6 m
V1-G-5M-PUR ABG-V1-W	Length 5 m
V1-G-10M-PUR ABG-V1-W	Length 10 m
V1-G-20M-PUR ABG-V1-W	Length 20 m



### Protective Cover

Model	Description
MVC-SH1	Protects against weld splash and mechanical damage

See pages 83-96 for complete RFID accessory listing.

# IDENT I System P



**Overview .....59**  
**Read Head and Bases ..... 60-65**  
**Network Adapters ..... 66-69**  
**Tags ..... 70-76**

## Overview

IDENT I System P is a single read head solution with common industrial protocol connections. The universal read head connects directly to the base of your choice. Ethernet and DeviceNet adapters are also available to connect to your network.

## Food Industry

Special bases for RS-232, RS-485 and PROFIBUS are available for the food industry. These bases are machined out of a solid block of stainless steel and will hold up under the harshest of conditions.

## Networking Options

IDENT I System P can be connected to industrial protocols like DeviceNet, PROFIBUS, INTERBUS, and Modbus/TCP. PC and certain PLC users may want to take advantage of the simple serial protocol and communicate via RS-232, RS-485 or TCP/IP.

## High Baud Rates for Fast Access Speeds

PROFIBUS works up to 12 Mbps, INTERBUS has been updated to the modern 2 Mbps specification, and RS-232/RS-485 bases will work great up to 38.4 kbps.

## Quick Setup

All RS-232 bases use point-to-point protocols so no setup or software is required to program the read head. RS-485, PROFIBUS and INTERBUS bases use DIP switches to set their address. DIP Switch setup is perfect for automotive and factory automation customers because the new settings can be transferred even when the old hardware is damaged and without power.

## 125 kHz Industrial Tags

IDENT I System P will read all IPC tags operating at the 125 kHz frequency. Read/Write tags range from 5 bytes up to 8192 bytes. Also, the read only tags carry a 5 byte unique identifier that is guaranteed never to repeat. Tags can be embedded in metal or surface mounted on any surface. Low cost commercial tags are also available for a variety of applications.

## Mounting Hardware

If the read heads are installed in a rigid bracket, it is difficult to make adjustments. P+F offers RAM mounting hardware that makes it easy to adjust the readers. The distance between the tag and head may need to change depending on the mounting of the tag and the speed at which the tag passes the head.

## Industrial Housings

All of the heads use a base made from high strength industrial aluminum or stainless steel. Grounding can easily be achieved by bolting the base to a clean metal surface. See below for some of the other features our bases have to offer.

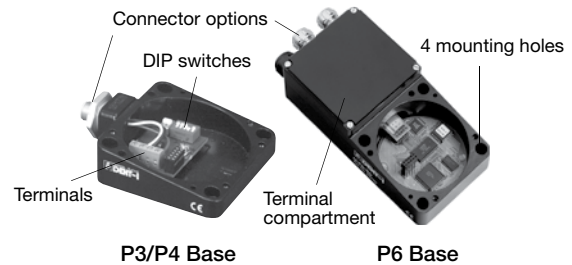

## Network Adapters

Every IDENT I System P installation requires a read head, base, and optionally, a network adapter. Network adapters for Ethernet allow up to 16 read heads to be connected to one Ethernet cable for quick data acquisition or industrial control. DeviceNet is a very common industrial protocol and all read heads and the coupler itself are powered off of the DeviceNet line. This makes installation easy.



### IDENT I System P Read Head and Bases

- Single read head solution 1 head, 1 base, 1 network connection
- 4" of read range
- Choose PROFIBUS, RS-232, RS-485 or INTERBUS
- DIP switch addressable
- Reads and writes any low frequency IPC tag

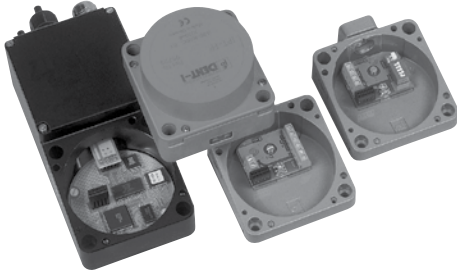

#### IDENT I System P Read Head

The choices are simple here. One read head is used with a number of base options including RS-232, RS-485, PROFIBUS, and INTERBUS. The read head will communicate to all low-frequency IPC... type tags. There are three LEDs that help to diagnose and troubleshoot the system. The first is power, the second is the read/write success and the last one is for bus error. If the INTERBUS or PROFIBUS connections are not made the Bus Err LED will be solid RED.

#### IDENT I System P Bases

The IDENT I System P Bases contain all electrical connections for the read head as well as any DIP switch setting. There are two versions of the base. There is the short version for RS-232/RS-485 and the long version for PROFIBUS and INTERBUS. There are also stainless steel versions that are perfect for the food industry.

#### Mounting hardware

If the read heads are installed in a rigid bracket, it is impossible to make adjustments. P+F offers RAM mounting hardware that makes it easy to adjust the readers. The distance between the tag and head may need to change depending on the mounting of the tag and the

speed at which the tag passes the head.

#### RS-232/RS-485 point-to-point

Point-to-point models are designed to connect a single head to a single serial port. That port can be RS-232 or RS-485. The P+F protocol is easy to use. You send a command and you get a response when the command is executed. Many commands are available to the user. Also, the read head can run automatically on power up and send data as the tags arrive in front of the read head.

#### RS-485 multidrop

The multidrop bases are ideal for connecting many heads to a single serial port. The bases are addressable 1-30, and up to 30 read heads can be connected to a single cable. RS-485 can be run up to 2000 feet with no communication loss. This protocol is ideal for PC applications and also connects to our DeviceNet bus coupler. For DeviceNet, however, only a single head at address 1 is supported on each port.

#### PROFIBUS

To connect multiple heads to a single cable this is probably the simplest and fastest hardware to use. You can hardwire the PROFIBUS cable or use the single quick disconnect option. If using a quick disconnect, a single head can be removed without taking down the entire network. Over 100 heads can be attached to a single network.

#### INTERBUS

This is one of the few INTERBUS options that P+F offers. This base was recently redesigned to incorporate the baud rate selection switch so that 500 kbit/s and 2 Mbit/s are now both supported. The quick disconnect option now makes installation even easier. The real advantage of INTERBUS is its almost limitless cable length. There can be up to 512 participants on the bus and the INTERBUS cable can be up to 12.8 kilometers with up to 400 meters between any two devices.



## IDENT I System P Read Head

HOUSING STYLE	Extended Flat Pack
MODEL	IPT1-FP
FREQUENCY	125 kHz
LED FUNCTIONALITY	Green power, amber tag read, red bus error
MOUNTING	1500 mm <small>Min. distance between two heads</small>
OPERATING VOLTAGE	20-30 VDC from base
TEMPERATURE RANGE	<small>Working</small> -13°F to +158°F (-25°C to +70°C) <small>Storage</small> -40°F to +185°F (-40°C to +85°C)
PROTECTION (IEC)	IP67 (with base attached)
HOUSING MATERIAL	PBT
WEIGHT	12 oz
APPROVALS	CE
ELECTRICAL CONNECTION	Directly to base

## Dimensions (mm)

IPT1-FP

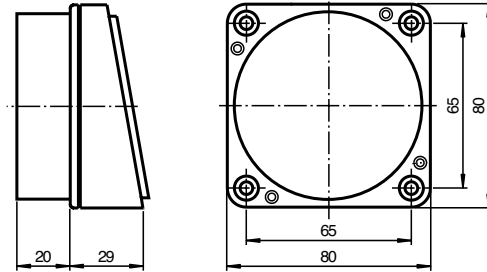

## IDENT I System P Bases

INDUSTRIAL NETWORK	RS-232/RS-485	RS-485 Multidrop	PROFIBUS	INTERBUS
MODEL(S)	<small>Standard</small> U-P4-RX	U-P4-R4	U-P6-B6	U-P6-B5
	<small>Metric Threads (M20)</small> U-P3-RX	U-P3-R4	-	-
	<small>Stainless Steel (M20)</small> U-P3V4A-RX	U-P3V4A-R4	U-P6V4A-B6	-
	<small>Quick Disconnect</small> -	U-P4-R4-V15	U-P6-B6-V15B	U-P6-B5-V
OPERATING VOLTAGE	20-30 VDC			
VOLTAGE RIPPLE	≤ 10% at 30 VDC			
POWER CONSUMPTION	4 W (with read head)		5 W (with read head)	
REVERSE POLARITY PROTECTION	Yes			
NETWORK PROTOCOLS	P+F ASCII	P+F ASCII multidrop	PROFIBUS DP	INTERBUS
BAUD RATES	up to 38.4 kbps	up to 38.4 kbps	up to 12 Mbps	500 kbps, 2 Mbps
ADDRESS	None, point-to-point	0 (point-to-point), 1-31 addressable	0-126	512 addresses
READ HEAD MAPPING	-	-	mixed	mixed
MIN/MAX DATA MAPPING SIZES	-	-	8 bytes/32 bytes	10 bytes
MAXIMUM READ/WRITE DATA IN SINGLE SCAN	1020 bytes		28 bytes	4 bytes
MESSAGING	-	-	DPV0	remote bus station
MAX. NETWORK CABLE LENGTH	RS-232 100 m, RS-485 1200 m	1200 m	1200 m	12800 m
PROTECTION (IEC)	IP67 (with read head attached)			
HUMIDITY	96% noncondensing, salt spray resistant			
TEMPERATURE RANGE	<small>Working</small> -13°F to +158°F (-25°C to +70°C) <small>Storage</small> -40°F to +185°F (-40°C to +85°C)			
HOUSING MATERIAL	Aluminum or stainless steel			Aluminum
WEIGHT	7 oz	7 oz	27 oz	27 oz
APPROVALS	CE			
READ HEAD CONNECTION	Direct read head connection			
POWER AND BUS CONNECTIONS	Terminals	Terminals	Terminals	Terminals
	-	5-pin male M12 quick disconnect	5-pin male M12 B-coded quick disconnect + 4-pin male M12 quick disconnect for power	2 - male M23 quick disconnects

## Wiring Diagrams

**U-P4-RX**  
**U-P3-RX**  
**U-P3V4A-RX**

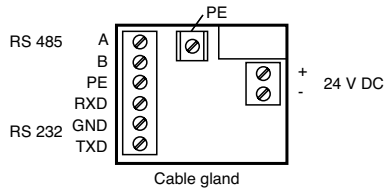

**U-P4-R4**  
**U-P3-R4**  
**U-P3V4A-R4**

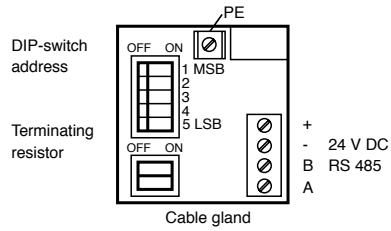

**U-P4-R4-V15**

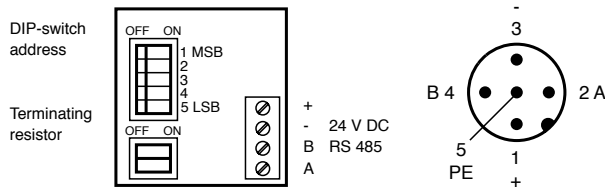

**U-P6-B6**  
**U-P6V4A-B6**

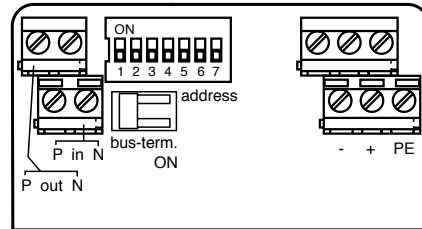

**U-P6-B6-V15B**

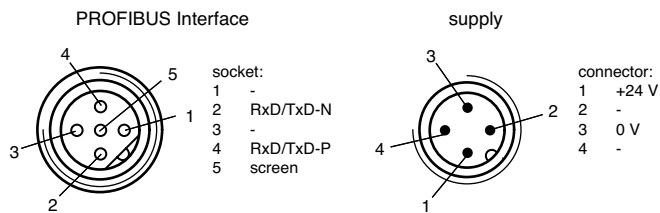

**U-P6-B5**

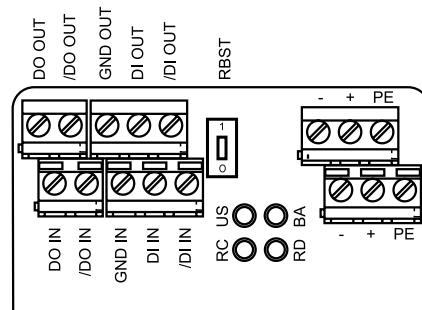

**U-P6-B5-V**

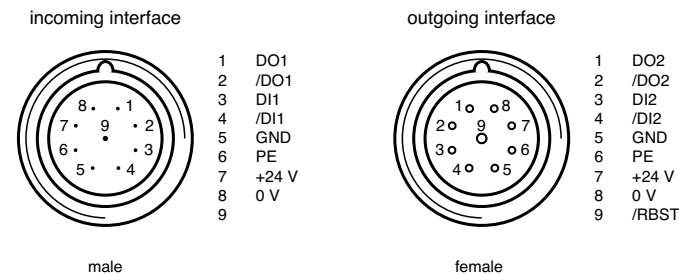



## Dimensions (mm)

U-P4-RX  
U-P4-R4

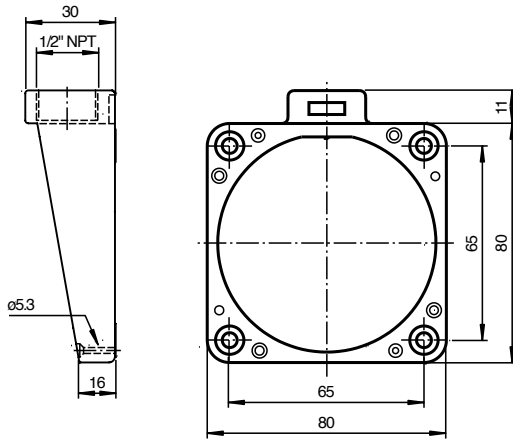

U-P3-RX  
U-P3V4A-RX



U-P3-R4  
U-P3V4A-R4

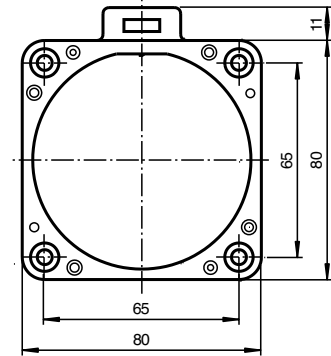

U-P4-R4-V15

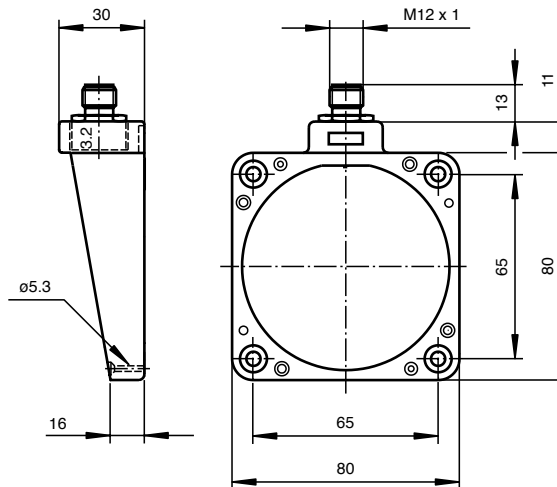

U-P6-B6  
U-P6V4A-B6  
U-P6-B5

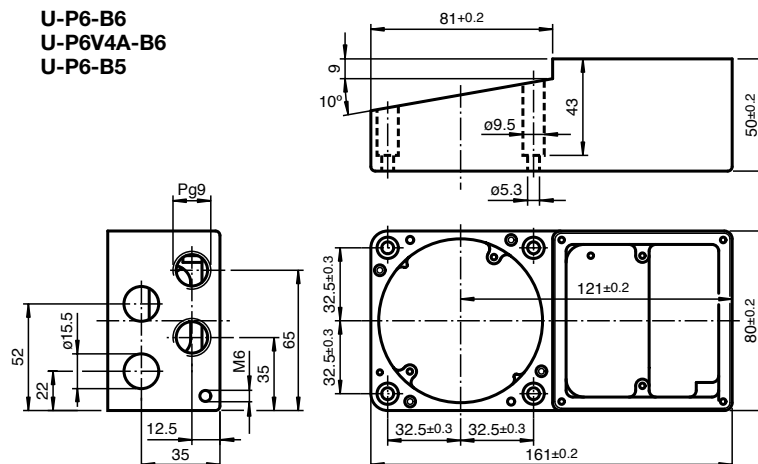

## Dimensions (mm)

**U-P6-B6-V15B**

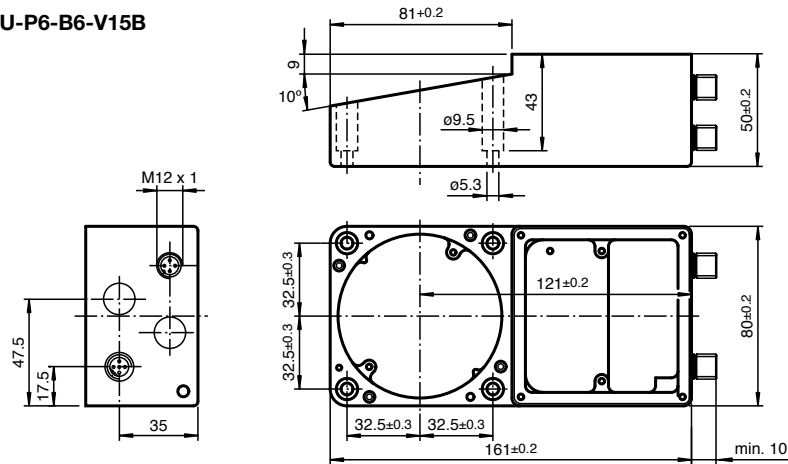

**U-P6-B5-V**

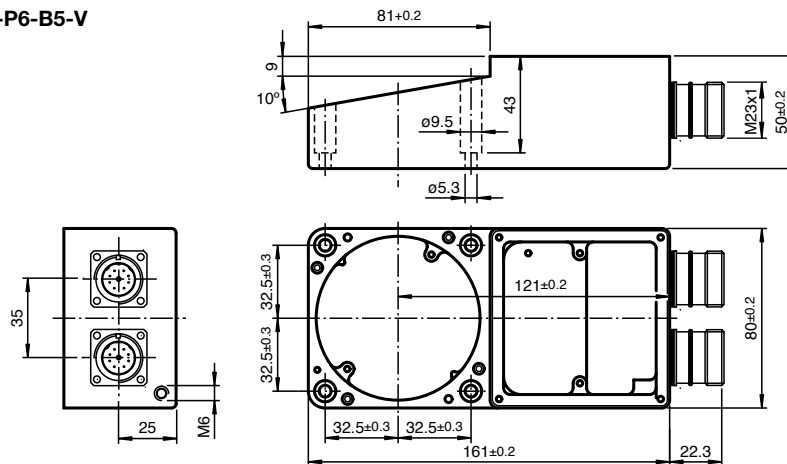

## Accessories

### Power Cables

Model	Description
V1-G-2M-PUR	Length 2 m, PUR jacket
V1-G-5M-PUR	Length 5 m, PUR jacket
V1-G-10M-PUR	Length 10 m, PUR jacket
V1-G-2M-PVC	Length 2 m, PVC jacket
V1-G-5M-PVC	Length 5 m, PVC jacket
V1-G-10M-PVC	Length 10 m, PVC jacket

### Power Distribution Using Flat Cable with Piercing Technology

Model	Description
VAZ-FK-R-BK	Flat black cable, 8 A oil resistant
VAZ-FK-S-BK	Flat black cable, 8 A standard
VAZ-T1-FK-.3M-PUR-V1-G	Flat cable power adapter, length .3 m
VAZ-T1-FK-1M-PUR-V1-G	Flat cable power adapter, length 1 m
VAZ-2FK-B3	Flat cable splitter for machine breaks
VAZ-FK-ST1	Shrink tube to cover open ends (20)

## Accessories

IDENT I System P Read Heads and Bases

### PROFIBUS Accessories

Model	Description
ICZ-3T-V15B	B-coded tee
ICZ-TR-V15B	B-coded terminator
ICZ-3T-0.2M-PUR ABG-V15B-G	B-coded y cable
ICZ-2T/TR-0.2M-PUR ABG-V15B-G	B-coded y cable termination
V15B-G	B-coded field attachable female
V15SB-G	B-coded field attachable male
V15B-G-0.6M-PUR ABG-V15B-G	B-coded extension cable .6 m
V15B-G-1M-PUR ABG-V15B-G	B-coded extension cable 1 m
V15B-G-2M-PUR ABG-V15B-G	B-coded extension cable 2 m
V15B-G-5M-PUR ABG-V15B-G	B-coded extension cable 5 m
V15B-G-7M-PUR ABG-V15B-G	B-coded extension cable 7 m
V15B-G-12M-PUR ABG-V15B-G	B-coded extension cable 12 m
V15B-G-15M-PUR ABG-V15B-G	B-coded extension cable 15 m
VAZ-PB-CABLE	Raw PROFIBUS cable 100ft
VAZ-PB-DB9-W	DB9 PROFIBUS connector with termination switch



### Mounting Brackets

Model	Description
RAM-2461-Y906430	Mounting plate for FP read heads
RAM-101U	Adjustable RAM mounting arm
RAM-200-1	Adjustable RAM mount with 1/2" NPT entrance



### Raw cable for RS-232/RS-485

Model	Description
VAZ-RK-8163	6 conductor cable shielded, 1000 ft spool

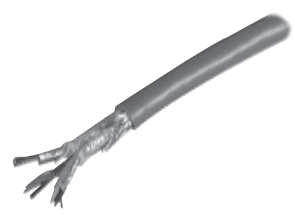

See pages 83-96 for complete RFID accessory listing.

### IDENT I System P Network Adapters

- DeviceNet coupler for up to 2 read heads all powered by the bus
- 10/100 Mbit/s TCP/IP and Modbus/TCP Ethernet protocols
- 4-, 8-, and 16-port Ethernet to serial adapters



The IDENT I System P line supports TCP/IP, Modbus/TP, and DeviceNet using existing serial read heads. If the read head size is not a concern, IDENT I System P may be the right solution. If a smaller read head is required, IDENT Contol could be a possible option.

#### Ethernet

The Multiport DeviceServers are not specifically designed for P+F serial devices, but they do have special firmware to enhance the performance and programming of any serial device, including IDENT I System P. The P+F protocol is completely integrated into the DeviceServer making programming easy for the application developer.

#### Ethernet protocols and features

##### TCP/IP

The real advantage of these device servers is the one-to-one relationship between the read head and the Ethernet port. For example, read head 1 can be assigned Ethernet port 3001, and all other read head ports can also be assigned unique port numbers as well. No polling is required. When a tag comes into position, a command is sent directly to the required read head. The user specifies the length and the string of data. The device server automatically calculates the <checksum> and appends the terminating characters to the end of the string. The response data length is known because of the special commands sent to the System P read head.

#### ADMIN port

ADMIN port is another DeviceServer advantage. This unique feature is offered exclusively by Pepperl+Fuchs. A monitoring application opens this port, and information about the other open COM ports is sent at one-second intervals. This information includes whether or not the port is open, and the number of bytes transmitted and received. The system sends an alert if the port closes for any reason.

#### MIRROR ports

MIRROR ports are another Pepperl+Fuchs exclusive. They enable up to three applications to receive data from the same serial port. For example, serial port 1 has default socket connections to 3001, 4001, and 5001. Only port 3001 is set to send commands to the serial device. No other applications can interfere with production-critical hardware. Data returning from the serial port is sent to all default socket connections.

#### EMAIL

Another debug option is provided via email. There are over 10 different errors that can trigger an email, including device power up. This error could occur after a brownout.

#### Modbus/TCP

Modbus over Ethernet makes the connection to PCs, or PLCs seamless. The serial string terminations are automatic and Modbus debugging ports are included. This allows easy setup and diagnostics at the customer site or at remote locations. The IVI option attaches a <chk><etx> to the string, IRI attaches a <CR><LF> to the string, and GEN will attach no termination and can be used for any serial device regardless of the termination type.

#### DeviceNet

The DeviceNet bus coupler can handle up to 2 read/write heads. The same command can be sent to both heads simultaneously. The response data is sent back with the head number to easily distinguish the information. Because the standard read/write heads are used over RS-485, the distance between the head and the coupler can be up to 1,200 m. Special shielded 5 m, 10 m, and 20 m cables are available. The produced and consumed sizes are set to a compact 9 bytes in/9 bytes out. This allows many RFID systems to be put on to one network without worrying about running out of memory in the PLC.



## IDENT I System P Network Adapters

INDUSTRIAL NETWORK	Ethernet			DeviceNet
MODEL	RTS 4P DB9	RTS 8P DB9	RTS 16P	IPG-G4-B7-V15
USED WITH BASE	U-P4-RX, U-P3-RX, or U-P3V4A-RX			U-P4-R4-V15
NUMBER OF READ/WRITE HEADS SUPPORTED	4	8	16	2
LEDs	Status, Ethernet Link/Activity, Collision, 100MB Ethernet, RX/TX per port			Net, module, tx/rx each head
OPERATING VOLTAGE	100-240 VAC, or 24 VDC		100-240 VAC	20-30 VDC
VOLTAGE RIPPLE	≤ 10% at 30 VDC			
POWER CONSUMPTION	4.8 W	6.96 W	14.3 W	2.4 W
BUS CURRENT CONSUMPTION	-	-	-	100 mA @ 24 VDC
REVERSE POLARITY PROTECTION	Yes			
NETWORK PROTOCOLS	TCP/IP, Modbus/TCP			DeviceNet
BAUD RATES	10/100 Mbps			125, 250, 500 kbits/s
ADDRESS	Fixed IP, DHCP			0-63
READ HEAD MAPPING	separated			mixed
MIN/MAX DATA MAPPING SIZES	2 bytes/250 bytes			9 bytes
MAXIMUM READ/WRITE DATA IN SINGLE SCAN	240 bytes Modbus/TCP, 1020 bytes TCP/IP			4 bytes
MESSAGING	fc3, fc16 (Modbus/TCP)			-
MAX. NETWORK CABLE LENGTH	100 m to switch			100m to 500m
PROTECTION (IEC)	IP20			IP67
HUMIDITY	20% to 80% system on, 8% to 80 % system off			
TEMPERATURE RANGE	Working			-35°F to +165°F (-37°C to 74°C)
	Storage			-40°F to +185°F (-40°C to +85°C)
HOUSING MATERIAL	Steel			PA76-GF/PBT-GF20
WEIGHT	112 oz	120 oz	140 oz	15 oz
APPROVALS				
READ HEAD/BASE CONNECTION	DB9 male		RJ45	5-pin female M12 quick disconnect
POWER CONNECTION	110V USA plug, 220V European plug			
BUS CONNECTION	RJ45 in/ RJ45 out		RJ45	1m pigtail 5-pin male M12 quick disconnect

## Wiring Diagrams

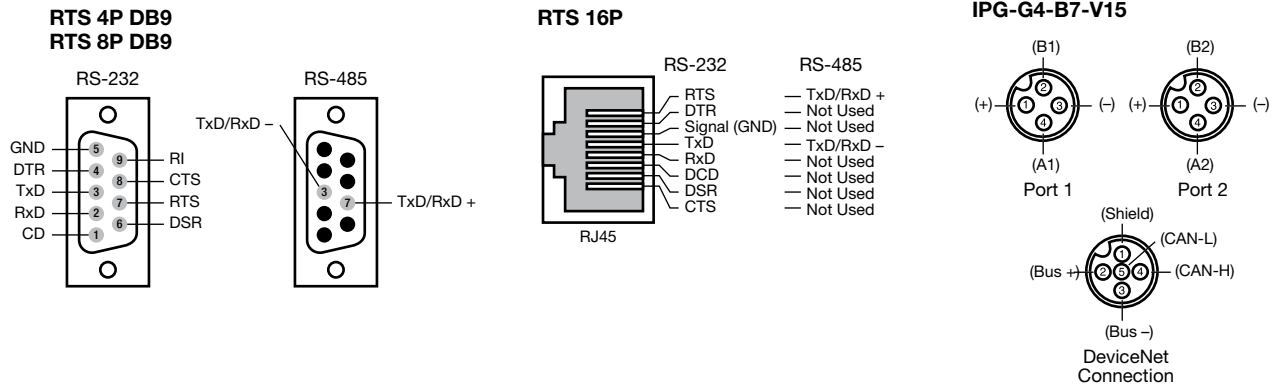

## Dimensions (mm)

RTS 4P DB9

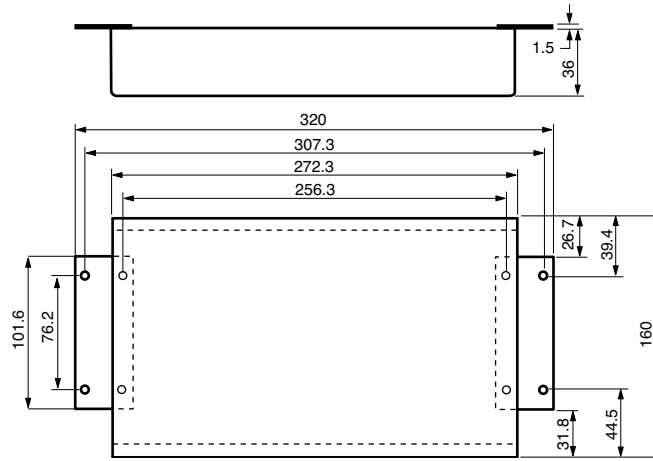

RTS 8P DB9

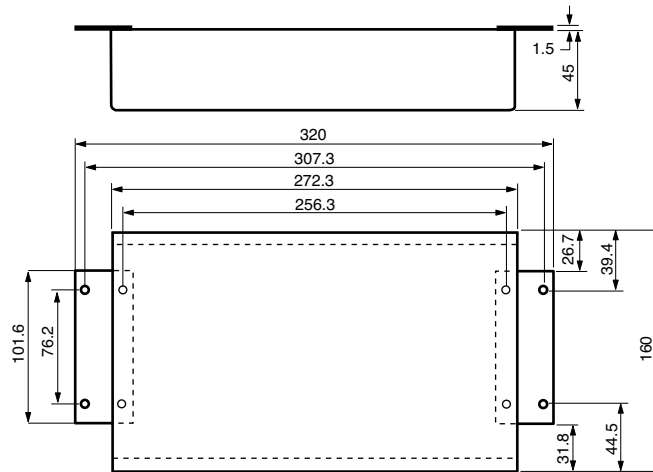

RTS 16P

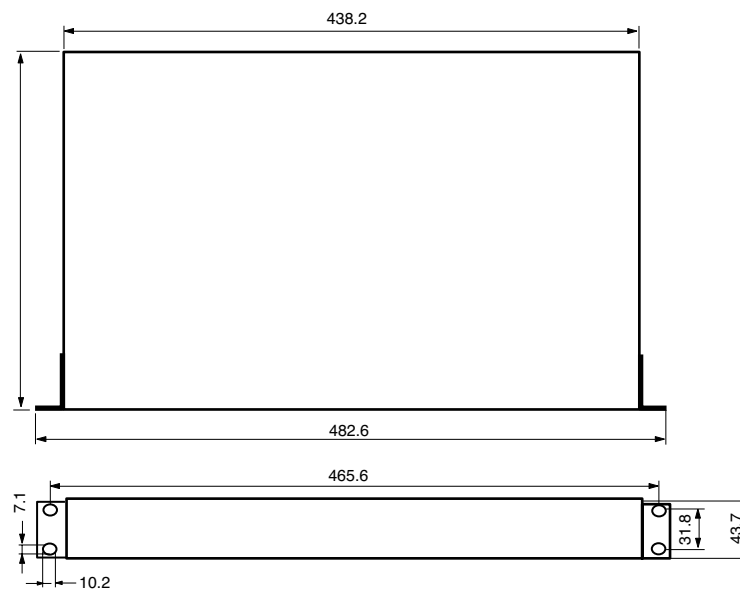

## Dimensions (mm)

IPG-G4-B7-V15

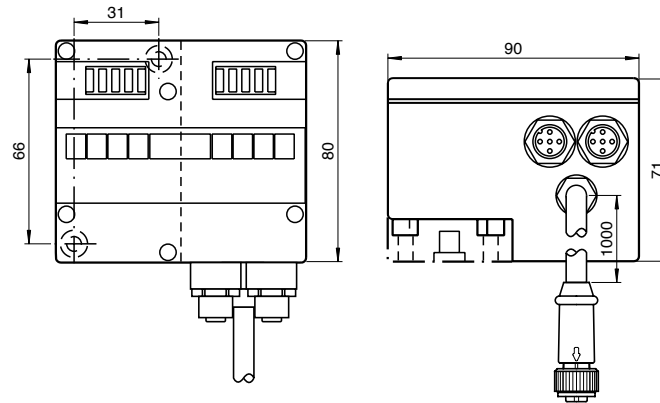

## Accessories

### DeviceNet Accessories

Model	Description
DNV95-G-TERM	MINI terminator 5-pin female
DNV95-G-0M-T-0M-V95-G-L	MINI tee
DNV15-G-YE1M-PVC-V95-G	Micro female to MINI male adapter 1 m
DNV95-G-BK5M-PVC-V95-G	MINI double-ended cable 5 m
DNV95-G-BK15M-PVC-V95-G	MINI double-ended cable 15 m
DNV95-G-BK25M-PVC-V95-G	MINI double-ended cable 25 m
DNV95-G-BK50M-PVC-V95-G	MINI double-ended cable 50 m



### Ethernet Accessories

Model	Description
V45-G-10M-PUR-V45-G	RJ45 cable, shielded 10 m



### Read Head Cables For DeviceNet Coupler

Model	Description
V15-G-YE5M-PVC-V15-G-ABG	Shielded read head cable 5m
V15-G-YE10M-PVC-V15-G-ABG	Shielded read head cable 10m
V15-G-YE25M-PVC-V15-G-ABG	Shielded read head cable 25m



See pages 83-96 for complete RFID accessory listing.

### IDENT I System P Tags

- Work with all IPH/IPT style read/write heads
- Tags are available in read only & read/write version
- Wide housing selections available for different applications
- Low cost tags with 5 bytes of data to FRAM tags with over 8000 bytes

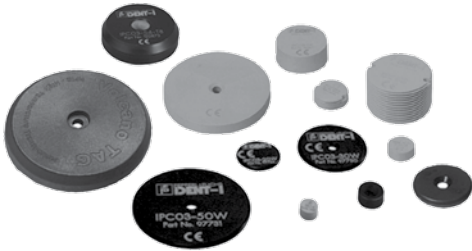

IDENT I System P tags come in a wide variety of housing styles and memory organizations. The flat pack style read head that is unique to IDENT I System P is perfect for tags with a 16 mm diameter or greater. Smaller tags can be used but the read range achieved may not be desirable for the application. If smaller tags are required IDENT Control has a wide selection of smaller read heads and many more tag options to choose from.

#### High Temperature

Many industrial applications have high- or extended-temperature applications. The Volcano tag is effective at temperatures exceeding 350 °F and other extended temperature tags withstand 250 °F and 300 °F environments.

#### FRAM

The Ferroelectric RAM tag is unique to IDENT I System P. This type of memory allows the tag to be written to an unlimited number of times. This tag has a large memory capacity of 64 kbits and is housed in a 58 mm diameter housing for direct mounting on any surface, including metal.

### Common Specifications

#### Series P Tags

OPERATING FREQUENCY	125 kHz
DATA TRANSFER RATE	2 kbit/s

#### Memory Segmentation

All tags have 32 bit memory blocks. Tags that are not FRAM have a 100,000 write limit. This memory segmentation is significant. If you switch to the next memory cell after the write limit is reached you get 100,000 more writes. The IPC03 tags have a write capacity of 2,900,000 if every cell on the tag is used.

#### IPC02 Read Only Tags

These tags have a 40 bit read only code in ROM that is guaranteed to be unique. They are among the least expensive tags on the market. All tags come preprogrammed with fixed data that cannot be changed by the user.

#### WORM Tags

Write Once Read Many tags are unique in that they have 40 bits of read/write memory that can emulate a read only IPC02 tag. As an IPC02 they can never be written again and have the same fast read speed. If left in the IPC11 mode, they are a high-speed, 5-byte read/write tag.





## IDENT I System P Tags

TYPE	Read Only		
MODEL	IPC02-16	IPC02-20CD	IPC02-20W
ISO STANDARD/CHIP TYPE	EM4102		
READ SPEED	40 ms		
READ ONLY MEMORY	5 byte ROM		
DATA RETENTION	for the life of the tag		
READ/WRITE RANGE IN AIR (AT 25°C) <i>IPT1-FP</i>	1-58 mm		
READ/WRITE RANGE IN AIR 7 MM SPACER TO STEEL (AT 25°C) <i>IPT1-FP</i>	0-44 mm		
PROTECTION (IEC)	IP69k	IP67	
TEMPERATURE RANGE	<i>Working</i>	-13°F to +185°F (-25°C to +85°C)	-4°F to +140°F (-20°C to +60°C)
	<i>Storage</i>	-13°F to +302°F (-25°C to +150°C)	-4°F to +140°F (-20°C to +60°C)
HOUSING MATERIAL	Epoxy	PE/PES	PC

## Dimensions (mm)

IPC02-16

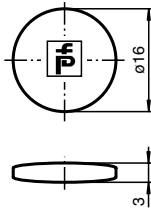

IPC02-20CD

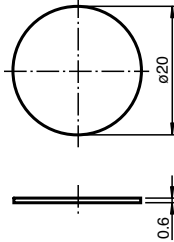

IPC02-20W

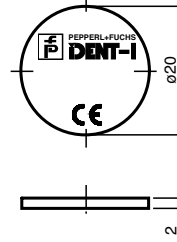

# RFID Systems

## IDENT I System P Tags



### IDENT I System P Tags

TYPE	Read Only (Continued)			
MODEL	IPC02-30W	IPC02-50W	IPC02-68-T7	IPC02-C1
ISO STANDARD/CHIP TYPE	EM4102			
READ SPEED	40 ms			
READ ONLY MEMORY	5 byte ROM			
DATA RETENTION	for the life of the tag			
READ/WRITE RANGE IN AIR (AT 25°C)	IPT1-FP 3-77 mm			2-98 mm
READ/WRITE RANGE IN AIR 7 MM SPACER TO STEEL (AT 25°C)	IPT1-FP 1-60 mm			1-78 mm
PROTECTION (IEC)	IP67			
TEMPERATURE RANGE	Working	-13°F to +158°F (-25°C to +70°C)	-40°F to +350°F (-40°C to +177°C)	+32°F to +122°F (0°C to +50°C)
	Storage	-40°F to +194°F (-40°C to +90°C)	-40°F to +350°F (-40°C to +177°C)	-40°F to +158°F (-40°C to +70°C)
HOUSING MATERIAL	PC		LCP	PVC
MOUNTING CONSIDERATIONS	#4 pan head max 4-6 in-lb torque	#6 pan head max 4-6 in-lb torque	#10 pan head max 4-6 in-lb torque	-

### Dimensions (mm)

IPC02-30W

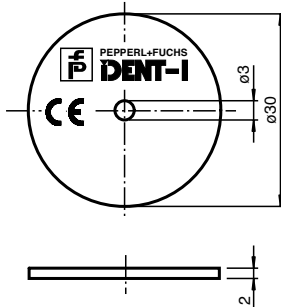

IPC02-50W

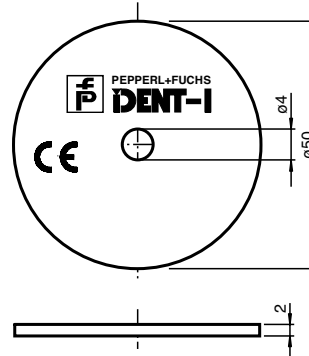

IPC02-68-T7



IPC02-C1

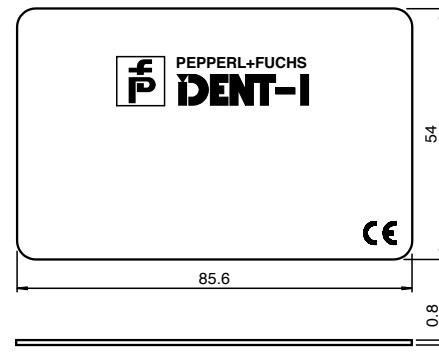



## IDENT I System P Tags

TYPE	WORM or Read/Write	
MODEL	IPC11-30	IPC11-50
ISO STANDARD/CHIP TYPE	Q5, emulates EM4102	
READ SPEED	40 ms	
WRITE SPEED	130 ms	
READ/WRITE MEMORY	5 byte EEPROM	
WRITE CYCLES	1 WORM, > 100,000 read/write	
DATA RETENTION	10 years at 55°C	
READ/WRITE RANGE IN AIR (AT 25°C) <i>IPT1-FP</i>	0-75 mm / 1-53 mm	2-98 mm / 0-64 mm
READ/WRITE RANGE IN AIR 7 MM SPACER TO STEEL (AT 25°C) <i>IPT1-FP</i>	0-59 mm / 1-41 mm	3-77 mm / 1-52 mm
PROTECTION (IEC)	IP67	
TEMPERATURE RANGE <i>Working</i>	-13°F to +158°F (-25°C to +70°C)	
<i>Storage</i>	-40°F to +194°F (-40°C to +90°C)	
HOUSING MATERIAL	PC	
MOUNTING CONSIDERATIONS	#4 pan head max 4-6 in-lb torque	#6 pan head max 4-6 in-lb torque

## Dimensions (mm)

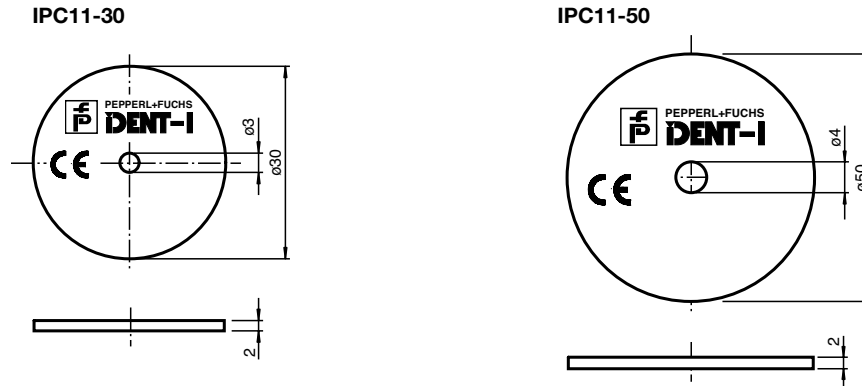

## Tag Mounting Spacer

Model	Description
IPZ-MH50	7 mm spacer, 50 mm diameter

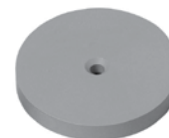



## IDENT I System P Tags

TYPE	Read/Write		
MODEL	IPC03-20K1	IPC03-20W	IPC03-30W
ISO STANDARD/CHIP TYPE	EM4450		
READ SPEED	100 ms+(30 ms each 4 byte word)		
WRITE SPEED	100 ms+(100 ms each 4 byte word)		
READ/WRITE MEMORY	116 byte EEPROM		
READ ONLY MEMORY	4 byte ROM		
WRITE CYCLES	> 100,000 per block		
DATA RETENTION	10 years at 55°C		
READ/WRITE RANGE IN AIR (AT 25°C)	<i>IPT1-FP</i> 1-58 mm / 0-34 mm	0-75 mm / 1-53 mm	
READ/WRITE RANGE IN AIR 7 MM SPACER TO STEEL (AT 25°C)	<i>IPT1-FP</i> 0-44 mm / 0-22 mm	0-59 mm / 1-41 mm	
PROTECTION (IEC)	IP67		
TEMPERATURE RANGE	<i>Working</i>	-13°F to +158°F (-25°C to +70°C)	
	<i>Storage</i>	-40°F to +194°F (-40°C to +90°C)	
HOUSING MATERIAL	PC		
MOUNTING CONSIDERATIONS	-		#4 pan head max 4-6 in-lb torque

## Dimensions (mm)

IPC03-20K1

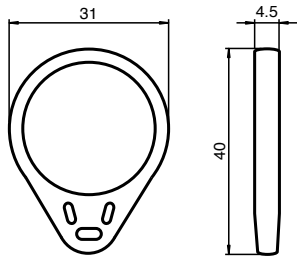

IPC03-20W

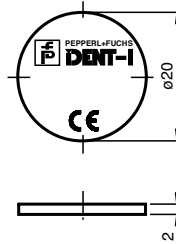

IPC03-30W

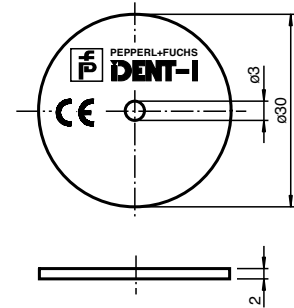



## IDENT I System P Tags

TYPE	Read/Write (Continued)		
MODEL	IPC03-50P	IPC03-C1	IPC03-100
ISO STANDARD/CHIP TYPE	EM4450		
READ SPEED	100 ms+(30 ms each 4 byte word)		
WRITE SPEED	100 ms+(100 ms each 4 byte word)		
READ/WRITE MEMORY	116 byte EEPROM		
READ ONLY MEMORY	4 byte ROM		
WRITE CYCLES	> 100,000 per block		
DATA RETENTION	10 years at 55°C		
READ/WRITE RANGE IN AIR (AT 25°C) <i>IPT1-FP</i>	3-101 mm / 3-93 mm		0-100 mm / 0-80 mm
READ/WRITE RANGE IN AIR 7 MM SPACER TO STEEL (AT 25°C) <i>IPT1-FP</i>	0-83 mm / 0-72 mm		
PROTECTION (IEC)	IP67		
TEMPERATURE RANGE	<i>Working</i>	-40°F to +158°F (-40°C to +70°C)	+32°F to +122°F (0°C to +50°C)
	<i>Storage</i>	-40°F to +194°F (-40°C to +90°C)	-40°F to +158°F (-40°C to +70°C)
HOUSING MATERIAL	PC, epoxy	PVC	Epoxy
MOUNTING CONSIDERATIONS	#6 flat head max 4-8 in-lb torque	-	#10 pan head max 4-8 in-lb torque

## Dimensions (mm)

IPC03-50P

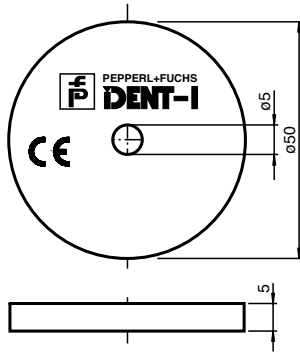

IPC02-C1

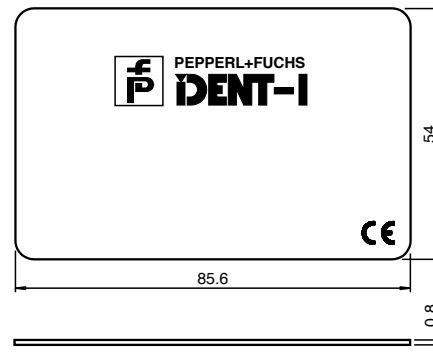

IPC03-100

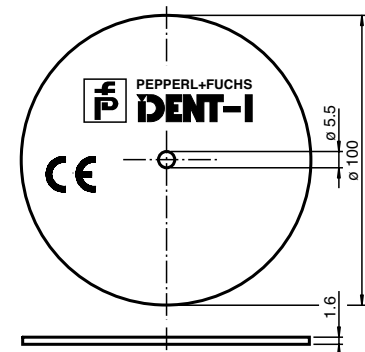

## Tag Mounting Spacer

Model	Description
IPZ-MH50	7 mm spacer, 50 mm diameter

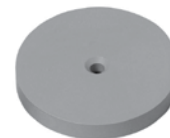



### IDENT I System P Tags

TYPE	Read/Write Surface Mount			
MODEL	IPC03-20CT	IPC03-54-T8	IPC03-58	IPC12-58-64K
ISO STANDARD/CHIP TYPE	EM4450			-
READ SPEED	100 ms+(30 ms each 4 byte word)			
WRITE SPEED	100 ms+(100 ms each 4 byte word)			
READ/WRITE MEMORY	116 byte EEPROM			8192 byte FRAM
READ ONLY MEMORY	4 byte ROM			
WRITE CYCLES	> 100,000 per block			unlimited
DATA RETENTION	10 years at 55°C			
READ/WRITE RANGE IN AIR (AT 25°C)	<i>IPT1-FP</i> 0-56 mm / 0-33 mm	3-106 mm / 2-92 mm	3-106 mm / 2-92 mm	0-53 mm / 0-46 mm
READ/WRITE RANGE ON STEEL (AT 25°C)	<i>IPT1-FP</i> 0-56 mm / 0-33 mm	0-85 mm / 0-76 mm	0-85 mm / 0-76 mm	0-42 mm / 0-38 mm
PROTECTION (IEC)	IP68	IP67	IP68	IP65
TEMPERATURE RANGE	<i>Working</i>	-13°F to +158°F (-25°C to +70°C)	-40°F to +248°F (-40°C to +120°C)	-13°F to +185°F (-25°C to +85°C)
	<i>Storage</i>	-40°F to +194°F (-40°C to +90°C)	-40°F to +248°F (-40°C to +120°C)	-13°F to +185°F (-25°C to +85°C)
HOUSING MATERIAL	Nylotron	PUR	PUR	PUR
MOUNTING CONSIDERATIONS	#10 pan head max 10-20 in-lb torque	#10 flat head max 4-6 in-lb torque	#10 flat head max 10-20 in-lb torque	#10 flat head max 10-20 in-lb torque

### Dimensions (mm)

IPC03-20CT

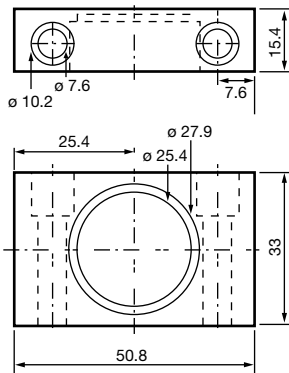

IPC03-54-T8

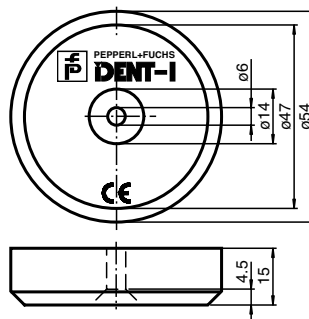

IPC03-58  
IPC12-58-64K

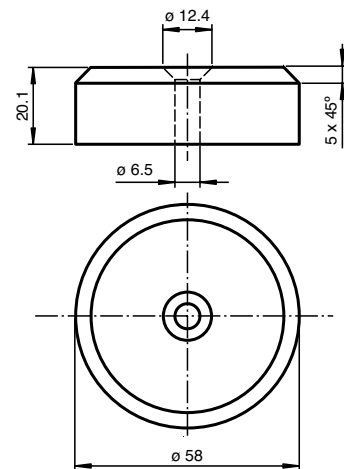



# Handheld Solutions

## Overview

Our IDENT control battery-operated handheld reader can be used to read or write data in the field without the use of a power cable. The IQT, IST, and IPT programmers have many unique features. The short-range handhelds are perfect for industrial, medical, and logistical applications. These can be stand-alone applications using only the graphical display, or active applications where data is written and read from a remote database. All features are supported right out of the box. The built-in, real-time clock is great for time stamping operations and keeping track of the entire process. Other features such as vibrator, buzzer, and language selection options can be useful in factory floor applications and multilingual production facilities.

## Wireless

The integrated 2.4 GHz, Class 1 radio can communicate up to 300 ft to any Bluetooth access point. Many Bluetooth and WiFi access points can coexist simultaneously due to adaptive frequency hopping and quick connect features. An XML router will guarantee data integrity over the transmission path. If the reader leaves the wireless area and reads a tag the data will be sent, if required, the moment it reenters the read zone. Wireless configuration is easy because you just type the device address you want to communicate to directly into the keyboard of the handheld and hit connect. The connection is maintained and configured automatically.

## Graphical Display and Keyboard

The handheld looks and feels like a cell phone. It has a multiline display, 18 buttons, and arrow selection keys. The screens are fully programmable so you can use the handheld as a stand-alone device or interface directly with a PC.

## Programming

The handheld readers use Javascript as their programming language. The Javascript application development kit can be downloaded free of charge and programs can be developed quickly and easily. Contact P+F for sample code and free programming assistance. The following features are available with the programming interface:

- Read and write to the reader's memory
- Display information on the screen

- Read information off the keyboard
- Access and transmit data through the communications port
- Reconfigure the communications port
- Read, write, and change configuration information on the handheld

## Communications

The RFID handheld is unique in that it has a single connector that does everything. It has the built-in ability to function as a USB virtual COM port, USB HID, PS/2, and RS-232 port. The Bluetooth wireless is also built-in. RS-232, PS/2, and USB cables can be purchased separately at any time. The RS-232 data rate, data bits, and stop bits are completely configurable from the display.

## Read/Write Range

All of the readers are designed for short-range operation. The range depends on the tag size and will vary from a fraction of an inch to approximately two inches. The handheld readers are typically used in installations where other fixed mount readers are located as well. Take note that activating a reader in close proximity to other readers will affect the range of both. The mutual interference will occur only when the read trigger button is pressed and only when they are close together.

## Battery Life

The readers can be used with a long-life battery. This battery is automatically recharged when plugged into a USB port, or when the battery is removed and placed into a charging station. There are many battery-saving features, such as a sleep mode timer with auto-shutoff, and backlight dimming. If the USB, PS/2, or RS-232 cables are used, the battery can be removed and replaced with a dummy to continue operation battery free.

## IDENT Control Handheld Programmings

- Wireless communication to 300 ft range
- USB, PS/2, RS-232, wireless all on one unit
- Graphical display and rugged keyboard standard
- Easy programming and configuration



### What is included?

All readers come standard with a Class 1 Bluetooth modem so all readers can be communicate wireless. Many other cable and battery accessories are available for a wide range of application requirements. You will need to purchase a battery or battery cover, a cable for communication if you require one and lastely, a charger if you plan on taking the battery out and charging it remotely. You can also charge the battery using the USB cable when plugged into your computer.

### Tag types/reader types

While the IST, IQT, and IPT program the same; each unit reads different tags. Before purchasing a handheld unit, ensure that it is compatible with your P+F or ISO standard tags. The IST unit reads IDC and ICC tags, the IQT reads IQC tags according to ISO 15693, and the IPT reads all IPC tags.

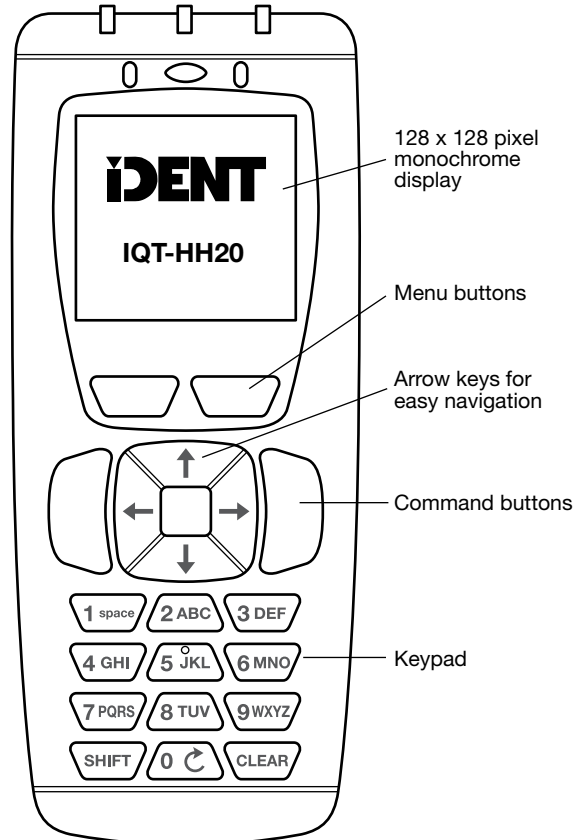

Actual size





## IDENT Control Handheld Programmers

FREQUENCY	125 kHz	250 kHz	13.56 MHz
MODEL	IPT-HH20	IST-HH20	IQT-HH20
TAGS SUPPORTED	IPC...	IDC..., ICC...	IQC...
LED	Green for read success		
DISPLAY	128 x 128 monochrome		
PUSH BUTTONS/FUNCTION KEYS	2 red, 1 blue, arrow keys alphanumeric keypad, shift, clear, + 2 keys		
COMMUNICATION OPTIONS	Bluetooth	Included, Class 1 Bluetooth radio 300 ft range	
	RS-232	Supported using optional cable/power supply, up to 115200 bps, 7 or 8 data bits, 1 or 2 stop bits, none odd even parity	
	PS/2	Supported using optional PS/2 cable	
	USB	Supported using optional USB cable	
BATTERY	Sold separately		
OPERATING VOLTAGE	4.3 VDC		
OPERATING CURRENT	400 mA, 525 mA Peak, 250 mA idle		
CLOCK	Real time Clock with 7 year on board battery backup		
MEMORY	4MB of memory for data and user programs		
PROGRAMMING OPTIONS	JavaScript programming environment; you can design menus, input screens, and read/write tags		
TEMPERATURE RANGE	Working	+32°F to +104°F (0°C to +40°C)	
	Storage	-4°F to +140°F (-20°C to +60°C)	
PROTECTION (IEC)	IP20		
HOUSING MATERIAL	PCABS		
WEIGHT	4.6 oz		
APPROVALS	<b>CE</b>		
COMMUNICATIONS CONNECTION	8 pin connector, cable not included		

## Dimensions (mm)

IPT-HH20  
IST-HH20  
IQT-HH20

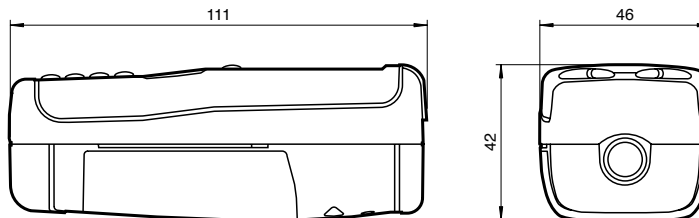

## Tags

### Series P Tags for IPT-HH20

Model Number	Size	Memory	Typical Mounting
IPC02-12	12 mm dia.	5 byte ROM	on plastic
IPC02-16	16 mm dia.	5 byte ROM	on plastic
IPC02-20CD	20 mm dia.	5 byte ROM	on plastic
IPC02-20W	20 mm dia.	5 byte ROM	on plastic
IPC02-30W	30 mm dia.	5 byte ROM	on plastic
IPC02-50W	50 mm dia.	5 byte ROM	on plastic
IPC02-68-T7	68 mm dia.	5 byte ROM	on plastic
IPC02-C1	85 mm x 54 mm	5 byte ROM	on plastic
IPC11-12	12 mm dia.	5 byte EEPROM	on plastic
IPC11-30	30 mm dia.	5 byte EEPROM	on plastic
IPC11-50	50 mm dia.	5 byte EEPROM	on plastic
IPC03-20K1	31mm dia.	116 byte EEPROM	on plastic
IPC03-20W	20 mm dia.	116 byte EEPROM	on plastic
IPC03-30W	30 mm dia.	116 byte EEPROM	on plastic
IPC03-50P	50 mm dia.	116 byte EEPROM	on plastic
IPC03-C1	85 mm x 54 mm	116 byte EEPROM	on plastic
IPC03-100	100 mm dia.	116 byte EEPROM	on plastic
IPC03-12.4	12.4 mm dia.	116 byte EEPROM	in metal
IPC03-16GK	M16	116 byte EEPROM	in metal
IPC03-24	24 mm dia.	116 byte EEPROM	in metal
IPC03-30GK	M30	116 byte EEPROM	in metal
IPC03-20CT	50 mm x 33 mm	116 byte EEPROM	on metal
IPC03-54-T8	43 mm dia.	116 byte EEPROM	on metal
IPC03-58	58 mm dia.	116 byte EEPROM	on metal
IPC12-58-64K	58 mm dia.	8192 byte FRAM	on metal

See pages 40-46 for complete specifications for Series P tags

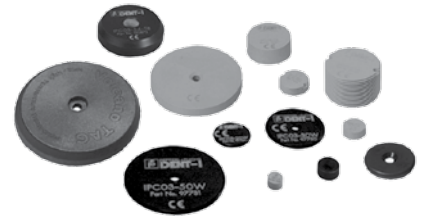

### Series S Tags for IST-HH20

Model Number	Size	Memory	Typical Mounting
ICC-8A	8 mm dia.	7 byte ROM	in metal
ICC-12A	12 mm dia.	7 byte ROM	in metal
ICC-12A-T1	12.4 mm dia.	7 byte ROM	in metal
ICC-16GKA	M16	7 byte ROM	in metal
ICC-30GKA-T1	M30	7 byte ROM	in metal
ICC-30GKA-T3	M30	7 byte ROM	in metal
ICC-50A	50 mm dia.	7 byte ROM	on plastic
IDC-8-1K	8 mm Dia	128 byte EEPROM	in metal
IDC-10-1K	10 mm dia.	128 byte EEPROM	in metal
IDC-12-1K	12 mm dia.	128 byte EEPROM	in metal
IDC-15-1K	15 mm dia.	128 byte EEPROM	in metal
IDC-16GK-1K	M16	128 byte EEPROM	in metal
IDC-24-1K	24 mm dia.	128 byte EEPROM	in metal
IDC-24-1K-Y94646	50 mm x 33 mm	128 byte EEPROM	on metal
IDC-30GK-1K	M30	128 byte EEPROM	in metal
IDC-30F-1K	30 mm dia.	128 byte EEPROM	on metal
IDC-50-1K	50 mm dia.	128 byte EEPROM	on plastic
IDC-50F-1K	50 mm x 50 mm	128 byte EEPROM	on plastic
IDC-58-1K	58 mm dia.	128 byte EEPROM	on metal

See pages 50-54 for complete specifications for Series S tags



## Series Q tag options for IQT-HH20

Model Number	Size	Memory	Typical Mounting
IQC21-30P	30 mm dia.	112 byte EEPROM	on plastic
IQC21-50P	30 mm dia.	112 byte EEPROM	on plastic
IQC21-58	58 mm dia.	112 byte EEPROM	on metal
IQC22-C5	42 mm x 30 mm	256 byte EEPROM	on plastic
IQC22-C1	85 mm x 54 mm	256 byte EEPROM	on plastic
IQC22-C4	96 mm x 64 mm	256 byte EEPROM	on plastic



See pages 34-35 for complete specifications for Series Q tags

## Accessories

### Handles and Grips

Model Number	Description
ODZ-MAH-GRIP	Clip-on pistol grip (requires battery or battery blank and cable)
ODZ-MAH-GRIP1	Ruggedized cable handle (requires cable)
ODZ-MAH-GRIP2	Ruggedized battery handle, 1950 mAH*
ODZ-MAH-GRIP3	Ruggedized battery handle, 3900 mAH*



\*We continuously improve our products, consult factory for current mAH ratings.

### Interconnect Cables

Model Number	Description
ODZ-MAH-CAB-B14	USB cable, 6 ft.
ODZ-MAH-CAB-B14-3.7M	USB cable, 12 ft.
ODZ-MAH-CAB-R2	RS-232 cable, 8 ft. (requires ODZ-MAH-5V-110V power supply)
ODZ-MAH-CAB-R6	PS/2 keyboard wedge cable, 8 ft.
ODZ-MAH-PWR-CABL	Charging cable (requires ODZ-MAH-5V-110V power supply)



### Batteries/Power Supplies

Model Number	Description
ODZ-MAH-BAT	High-capacity battery, 1950 mAH*
ODZ-MAH-BLANK	Battery blank (order interconnect cable separately)
ODZ-MAH200-CHARGER	Battery charger
ODZ-MAH-5V-110V	5 VDC power supply

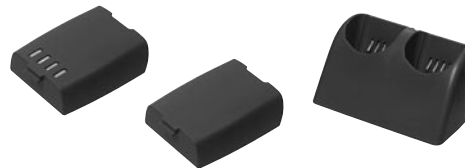

\*We continuously improve our products, consult factory for current mAH ratings.

### Bluetooth Modem

Model Number	Description
ODZ-MAH-B15	Wireless Bluetooth to USB, PS/2, or RS-232 (interconnect cable not included, see above)



CONTINUED

## Accessories

### Software

Model Number	Description
ODZ-MAH200-CODEROUTER	The CodeXML Router allows you to easily connect any RFID reader to a PDA running a Windows Mobile or CE application that accepts keystroke data (e.g., Word, Excel, Notepad).



See pages 83-96 for complete RFID accessory listing.

# RFID Accessories



<b>Power Cables.....</b>	<b>84</b>
<b>IDENT Control Read Head Cables.....</b>	<b>84-85</b>
<b>Read Head Cables for IDENT I System P DeviceNet Bus Coupler.....</b>	<b>86</b>
<b>Flat Cable Accessories .....</b>	<b>86-87</b>
<b>Serial Interface Accessories.....</b>	<b>87</b>
<b>Ethernet Accessories .....</b>	<b>88</b>
<b>DeviceNet Accessories .....</b>	<b>88-89</b>
<b>PROFIBUS Accessories.....</b>	<b>90-92</b>
<b>Mounting Accessories .....</b>	<b>92-93</b>
<b>Tag Accessories.....</b>	<b>94</b>
<b>Handheld Accessories .....</b>	<b>95-96</b>

# RFID Accessories

## Power Cables

These cables are designed to power the IDENT Control interface or IDENT I System P bases. They come in a PVC or PUR jacket with vibration resistant ratcheting head.

Model	Description
V1-G-2M-PUR	Length 2 m, PUR jacket
V1-G-5M-PUR	Length 5 m, PUR jacket
V1-G-10M-PUR	Length 10 m, PUR jacket
V1-G-2M-PVC	Length 2 m, PVC jacket
V1-G-5M-PVC	Length 5 m, PVC jacket
V1-G-10M-PVC	Length 10 m, PVC jacket

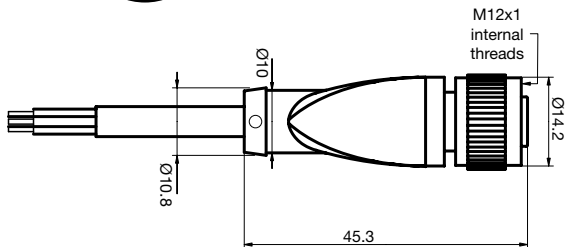
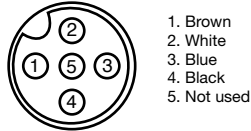

### Specifications

MATERIAL DATA	
Body	Green, flame resistant PVC or PUR
Insert	PUR
Cable Type	Gray, flexible PVC or PUR
Contacts	Machined copper and tin over gold
Contact Plating	Copper and tin over nickel
Wire Gauge	#22 AWG
Coupling Nut	Copper and tin over nickel
Cable Outer Diameter	4.5 mm
ELECTRICAL DATA	
Contact Resistance	≤5 mΩ
Electrical Isolation	1500 VAC
Current Rating	4 A
Voltage Rating	250 VAC
ENVIRONMENTAL DATA	
Protection Class	IP68/IP69k
Temperature Range	-13°F to +194°F (-25°C to +90°C)

## IDENT Control Read Head Cables

These cables are the highest quality shielded cables you can get. They are designed to connect the IDENT Control interface to the read head of Series Q, P, MV, or S. The shield connects to the coupling nut on both sides to provide superior shielding/grounding of your RFID system. (For more information see page 23, IDENT Control System Overview)

Model	Description
V1-G-.6M-PUR ABG-V1-W	Length .6 m
V1-G-5M-PUR ABG-V1-W	Length 5 m
V1-G-10M-PUR ABG-V1-W	Length 10 m
V1-G-20M-PUR ABG-V1-W	Length 20 m

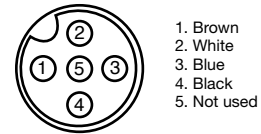

### Specifications

MATERIAL DATA	
Body	Black, PUR
Insert	PUR
Cable Type	Gray, flexible PUR
Wire Gauge	#22 AWG
Cable Outer Diameter	5.9 mm
Bend Radius	59 mm
ELECTRICAL DATA	
Contact Resistance	≤5 mΩ
Electrical Isolation	1500 VAC
Current Rating	4 A
Voltage Rating	250 VAC
ENVIRONMENTAL DATA	
Protection Class	IP67
Temperature Range	-22° to +176°F (-30°C to +80°C)

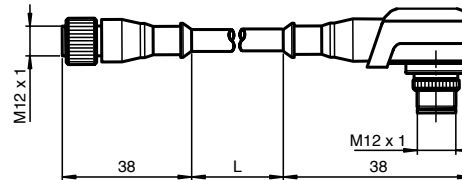

CONTINUED

## IDENT Control Read Head Cables (cont.)

These IDENT Control field attachables are perfect for wiring custom length, read head cables. The male is used on the IDENT Control interface and the female side connects to the read head. All wires between the read head and interface are connected straight through. The required wire gauge will depend on the length of the cable.

100 m use 4 conductor #22 AWG shielded cable  
 150 m use 4 conductor #20 AWG shielded cable  
 200 m use 4 conductor #18 AWG shielded cable

Model	Description
V1-G-IVH	Metal 4-pin female straight
V1-W-IVH	Metal 4-pin female right angle
V1S-G-IVH	Metal 4-pin male straight
V1S-W-IVH	Metal 4-pin male right angle

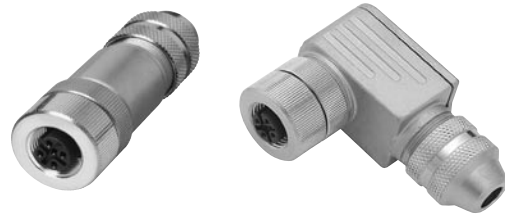

### Specifications

<b>MATERIAL DATA</b>	
Body	Nickel-plated brass
Cable Diameter Allowed	6-8 mm
<b>ELECTRICAL DATA</b>	
Current Rating	4 A
Voltage Rating	250 VAC
Connections	4 pins + shield connection to body
<b>ENVIRONMENTAL DATA</b>	
Protection Class	IP67
Temperature Range	-22° to +176°F (-30°C to +80°C)

V1-G-IVH

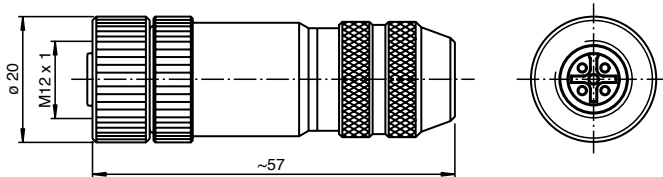

V1S-G-IVH

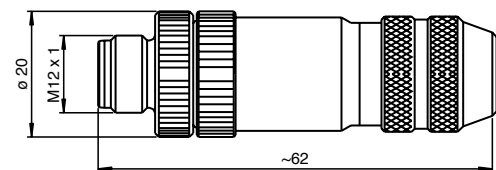

V1-W-IVH

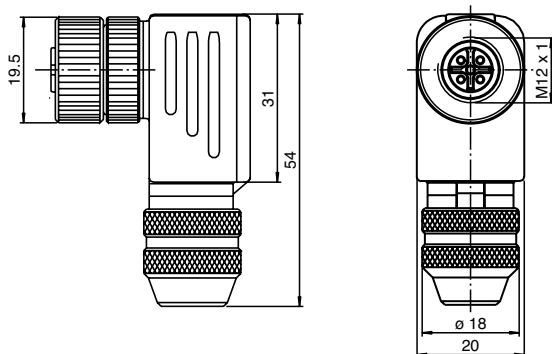

V1S-W-IVH

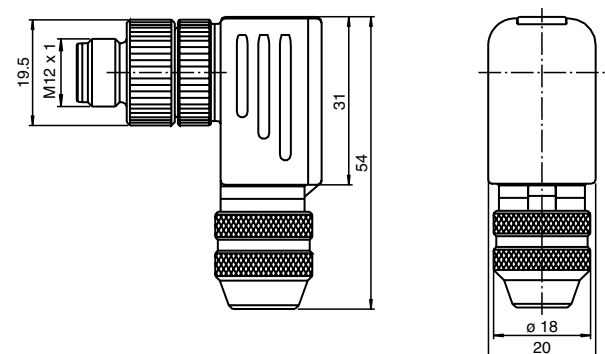

# RFID Accessories

## Read Head Cables for IDENT I System P DeviceNet Bus Coupler

These high-quality cables must be used to connect the base U-P4-R4-V15 to DeviceNet coupler IPG-G4-B7-B15. This double ended cable has a mesh shield that is connected to pin 5 on both ends of the cable. This is required because the DeviceNet coupler housing is plastic and the shielded must be grounded to the DeviceNet board itself.

Model	Description
V15-G-YE5M-PVC-V15-G-ABG	Shielded read head cable, 5 m
V15-G-YE10M-PVC-V15-G-ABG	Shielded read head cable, 10 m
V15-G-YE25M-PVC-V15-G-ABG	Shielded read head cable, 25 m



### Specifications

MATERIAL DATA	
Body	Yellow TPU
Insert	TPU with 20% glass fiber
Cable Type	Yellow PVC, with braided shield
Contacts	Gold-plated brass
Contact Plating	Copper and tin over nickel
Wire Gauge	#22 AWG
Coupling Nut	Nickel-plated diecast zinc
Cable Outer Diameter	5.6 mm
ELECTRICAL DATA	
Contact Resistance	≤5 mΩ
Electrical Isolation	1500 VAC
Current Rating	4 A
Voltage Rating	300 V
ENVIRONMENTAL DATA	
Protection Class	IP68/IP69k
Temperature Range	-22° to +221°F (-30°C to +105°C)

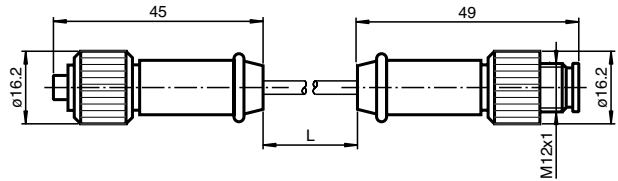

## Flat Cable Accessories

Flat cable is the simplest method of powering many IDENT Control interfaces or IDENT I System P bases to a central power supply. In this case 24 VDC is run throughout the machine and powers up all of your RFID controllers without the need for junction boxes, terminal strips, or conduit. All connections are rated IP69k and use piercing technology to quickly connect everything.

Model	Description
VAZ-FK-R-BK	Flat black cable, 8 A oil resistant
VAZ-FK-S-BK	Flat black cable, 8 A standard
VAZ-T1-FK-.3M-PUR-V1-G	Flat cable power adapter, length .3 m
VAZ-T1-FK-1M-PUR-V1-G	Flat cable power adapter, length 1 m
VAZ-2FK-B3	Flat cable splitter for machine breaks
VAZ-FK-ST1	Shrink tube to cover open ends (20)

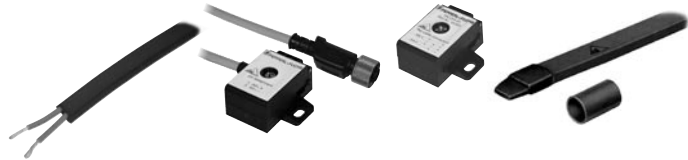

### Flat Cable Specifications

MATERIAL DATA	
Cable Type	TPE (oil resistant) or rubber mixture (standard)
Wire Gauge	#16 AWG
Bend Radius	12 mm on broad side
ELECTRICAL DATA	
Current Rating	8 A
Voltage Rating	300 V
ENVIRONMENTAL DATA	
Temperature Range	-40° to +185°F (-40°C to +85°C)

VAZ-FK-R-BK  
VAZ-FK-S-BK

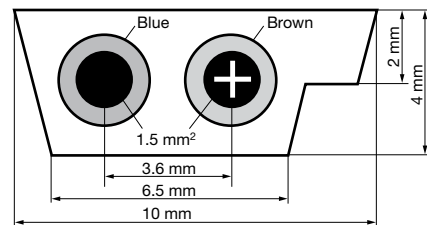

CONTINUED



## Flat Cable Accessories (cont.)

### Flat Cable Splitter Specifications

MATERIAL DATA	
Housing	PA6 GF35 Grivory
Body	Black PUR
Cable Type	Gray PUR
Contacts	Gold plated contacts
Wire Gauge	#22 AWG
Cable Outer Diameter	4.8 mm
ELECTRICAL DATA	
Current Rating	4 A (VAZ-T1-FK...) or 6 A (VAZ-2FK-B3)
Voltage Rating	35 VDC
ENVIRONMENTAL DATA	
Protection Class	IP68/IP69k
Temperature Range	-13° to +158°F (-25°C to +75°C)

VAZ-T1-FK-.3M-PUR-V1-G  
VAZ-T1-FK-1M-PUR-V1-G

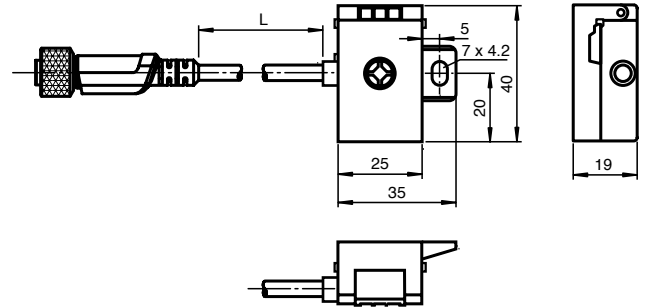

VAZ-2FK-B3

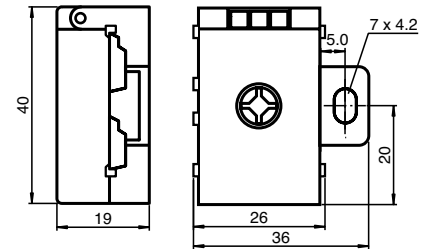

## Serial Interface Accessories

These accessories convert the IP67 rated IDENT Control back to a DB9 connection which may be required when connecting to a PC. Certain situations require long cable runs. These long runs can be more reliable by using a high quality, low impedance cable, such as the VAZ-RK-8163.

Model	Description
V1S-G-0.15M-PUR-SUBD	M12 to DB9 adapter .15 m
VAZ-R2-NULL	DB9 null modem cable 5 m
VAZ-RK-8163	6 conductor cable shielded, 1000ft spool



### Specifications for M12 to DB9 adapter

MATERIAL DATA	
Body	M12 molded to metal DB9 male
Cable Type	Black, PUR
Wire Gauge	#22 AWG
ENVIRONMENTAL DATA	
Protection Class	IP40
Temperature Range	-13° to +194°F (-25°C to +90°C)

### V1S-G-0.15M-PUR-SUBD

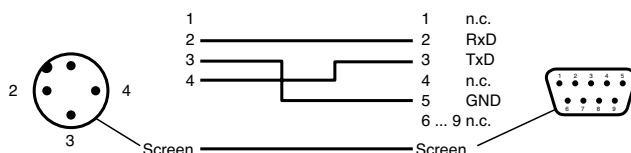

### Specifications for VAZ-RK-8163

MATERIAL DATA	
Cable Type	Gray PVC
Insulation Type	FPE
Contacts	Machined copper and tin over gold
Contact Plating	Copper and tin over nickel
Wire Gauge	#24 AWG
Number Of Conductors	3 pairs, 6 conductors
Shielding	Pairs shielded, also overall shielded
Drains	Yes, 4
Cable Outer Diameter	9.2 mm
ELECTRICAL DATA	
Current Rating	1.6 A per conductor
Voltage Rating	300 V RMS
ENVIRONMENTAL DATA	
Temperature Range	-40° to +140°F (-40°C to +60°C)

# RFID Accessories

## Ethernet Accessories

These two Ethernet accessories are designed for use in harsh industrial applications. The standard RJ45 ethernet connectors have been metalized and the cable itself completely shielded and molded to the head. This optional shroud adds superior mechanical protection, increases the IP rating to IP67, and makes the IDENT Control interface fully field mountable and IP67 rated.

Model	Description
ICZ-V45	RJ45 protective cover
V45-G-10M-V45-G	RJ45 cable, shielded 10 m



### Specifications for RJ45 Cable

MATERIAL DATA	
Cable Type	Shielded, with metal connectors
ELECTRICAL DATA	
Ethernet Spec	CAT 5 patch cable up to 100 Mbps
Wire Awg	24 AWG
ENVIRONMENTAL DATA	
Protection	IP67 when using ICZ-V45

## DeviceNet Accessories

DeviceNet is one of the most common industrial busses in North America. The trunk line can be run down the length of your machine and each Tee will connect to your RFID system of choice. There is a termination resistance of 121Ω is required at the beginning and end of each network.

Model	Description
DNV95-G-TERM	MINI terminator 5-pin female
DNV95-G-0M-T-0M-V95-G-L	MINI tee
DNV15-G-YE1M-PVC-V95-G	Micro female to MINI male adapter 1 m
DNV95-G-BK5M-PVC-V95-G	MINI double-ended cable 5 m
DNV95-G-BK15M-PVC-V95-G	MINI double-ended cable 15 m
DNV95-G-BK25M-PVC-V95-G	MINI double-ended cable 25 m
DNV95-G-BK50M-PVC-V95-G	MINI double-ended cable 50 m



**CONTINUED** →

### Specifications for Tee (DNV95-G-0M...) and Terminator (DNV95-G-TERM)

MATERIAL DATA	
Body	Black Santoprene
Cable Type	Black Santoprene
ELECTRICAL DATA	
DeviceNet Gauge	24 AWG with 22 AWG drain
Power Gauge	22 AWG
Contacts	Machined brass, gold plated
Contact Resistance	≤ 5mΩ
Resistance	121Ω for Terminator only
Electrical Isolation	1600 VAC
Voltage Rating	300 VAC
Current Rating	3 A
ENVIRONMENTAL DATA	
Protection Class	IP68
Temperature Range	-4° to +176°F (-20°C to +80°C)

DNV95-G-TERM

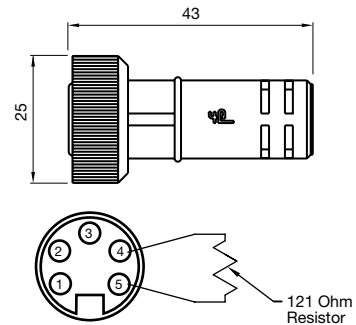

DNV95-G-0M-T-OM-V95-G-L

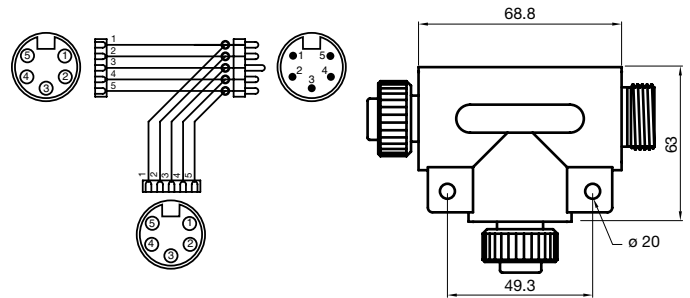

### Specifications for Drop Cables (DNV15-...)

MATERIAL DATA	
Body	Yellow TPE
Cable Type	Yellow CPE
ELECTRICAL DATA	
DeviceNet Gauge	24 AWG with 22 AWG drain
Power Gauge	22 AWG
Contacts	Machined brass, gold plated
Contact Resistance	≤ 5mΩ
Electrical Isolation	1600 VAC
Voltage Rating	300 VAC
Current Rating	3 A
ENVIRONMENTAL DATA	
Protection Class	IP68
Temperature Range	-4° to +176°F (-20°C to +80°C)

DNV15-G-YE1M-PVC-V95-G

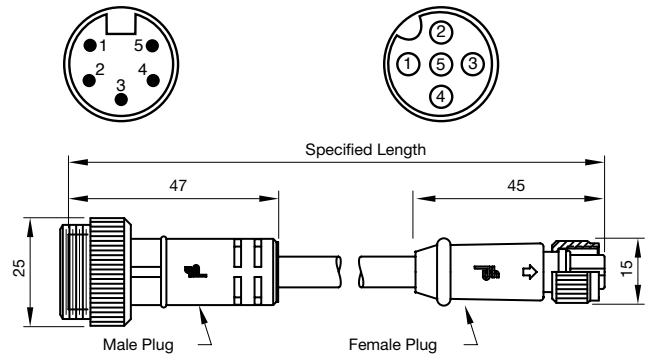

### Specifications for Trunk Cables (DNV95-G-BK...)

MATERIAL DATA	
Body	Black PVC
Cable Type	Gray PVC
ELECTRICAL DATA	
DeviceNet Gauge	18 AWG with 18 AWG drain
Power Gauge	15 AWG
Contacts	Machined brass, gold plated
Contact Resistance	≤ 5mΩ
Electrical Isolation	1600 VAC
Voltage Rating	300 VAC
Current Rating	8 A
ENVIRONMENTAL DATA	
Protection Class	IP68
Temperature Range	-4° to +221°F (-20°C to +105°C)

DNV95-G-BK...M-PVC-V95-G

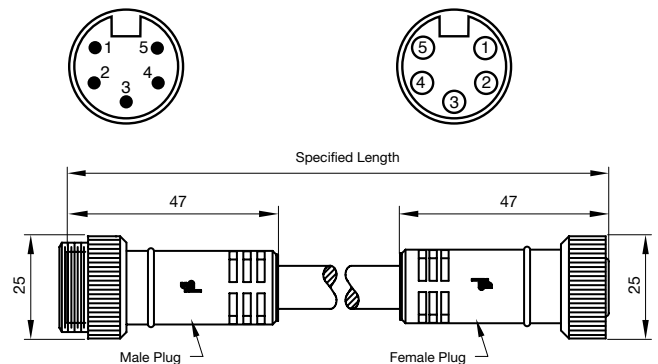

# RFID Accessories

## PROFIBUS Accessories

PROFIBUS is a common industrial bus all over the world. Many connector options are available including the tee which gives you a 100% molded design, Y cables for ultimate flexibility, DB9 connectors with built in termination switches for panel mounting, and extension cables to go from RFID system to RFID system.

Model	Description
ICZ-3T-V15B	b-coded tee
ICZ-TR-V15B	b-coded terminator
ICZ-3T-0.2M-PUR ABG-V15B-G	b-coded Y cable
ICZ-2T/TR-0.2M-PUR ABG-V15B-G	b-coded Y cable termination
V15B-G	b-coded field attachable female
V15SB-G	b-coded field attachable male
V15B-G-0.6M-PUR ABG-V15B-G	b-coded extension cable 0.6 m
V15B-G-1M-PUR ABG-V15B-G	b-coded extension cable 1 m
V15B-G-2M-PUR ABG-V15B-G	b-coded extension cable 2 m
V15B-G-5M-PUR ABG-V15B-G	b-coded extension cable 5 m
V15B-G-7M-PUR ABG-V15B-G	b-coded extension cable 7 m
V15B-G-12M-PUR ABG-V15B-G	b-coded extension cable 12 m
V15B-G-15M-PUR ABG-V15B-G	b-coded extension cable 15 m
VAZ-PB-CABLE	Raw PROFIBUS cable 100 ft
VAZ-PB-DB9-W	DB9 PROFIBUS connector with termination switch



### Specifications for PROFIBUS B-coded Tee and Terminator (ICZ-3T...)(ICZ-TR)

MATERIAL DATA	
Body	Black PUR oil resistant
Contact Plating	Gold plated
Coupling Nut	Nickel plated
ELECTRICAL DATA	
Contact Resistance	≤5 mΩ
Baud Rate	Max 12 Mbps
ENVIRONMENTAL DATA	
Protection Class	IP65
Temperature Range	-40° to +176°F (-40°C to +80°C)

#### ICZ-3T-V15B

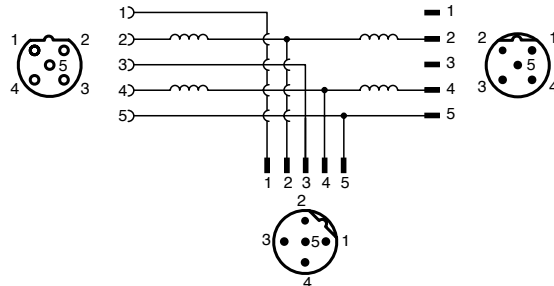

#### ICZ-TR-V15B

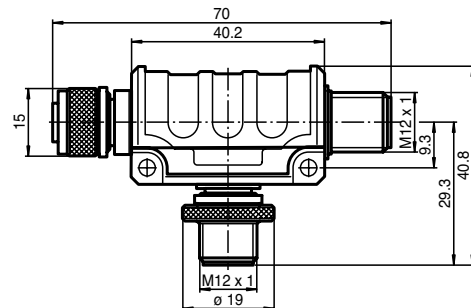
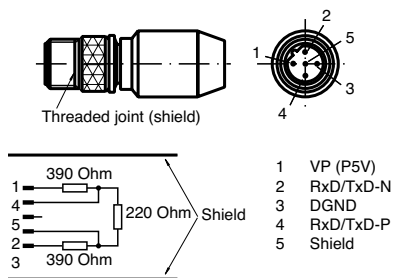

CONTINUED

## PROFIBUS Accessories (cont.)

### Specifications for PROFIBUS B-coded extension cables (V15B...) and Y cables (ICZ-3T, ICZ-2T)

MATERIAL DATA	
Body	Black PUR, PA66
Cable Type	Purple PUR
Contact Plating	Gold plated
Coupling Nut	Nickel plated
Cable Outer Diameter	8 mm
ELECTRICAL DATA	
Contact Resistance	≤5 mΩ
Baud Rate	Max 12 Mbps
Conductors	Fine Stranded
ENVIRONMENTAL DATA	
Protection Class	IP65
Temperature Range	-40° to +185°F (-40°C to +85°C)

#### ICZ-3T-0.2M-PUR ABG-V15B-G

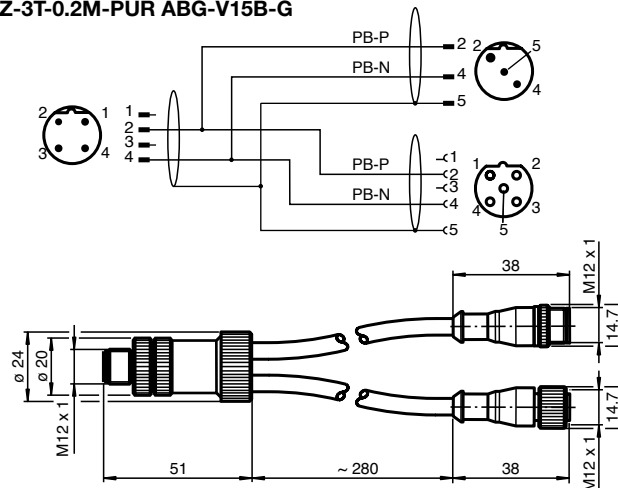

#### ICZ-2T/TR-0.2M-PUR ABG-V15B-G

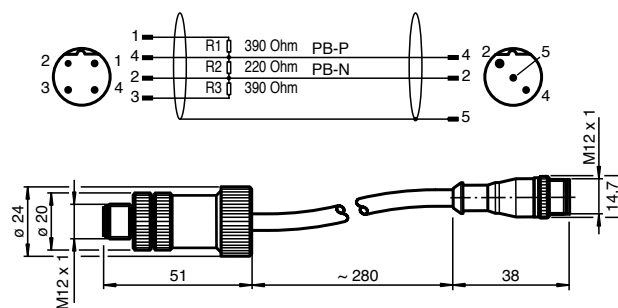

#### V15B-G-...M-PUR ABG-V15B-G

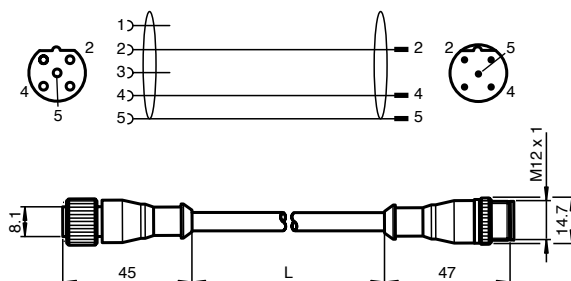

### Specifications for Metal B-coded field attachables (V15B-G AND V15SB-G)

MATERIAL DATA	
Body	Metal, nickel-plated brass
Cable Diameter	Excepts cables from 6...8mm DIA
ELECTRICAL DATA	
Baud Rate	Max 12 Mbps
Current Rating	4 A
Voltage Rating	125 VDC
ENVIRONMENTAL DATA	
Protection Class	IP65
Temperature Range	-40° to +176°F (-40°C to +80°C)

#### V15B-G

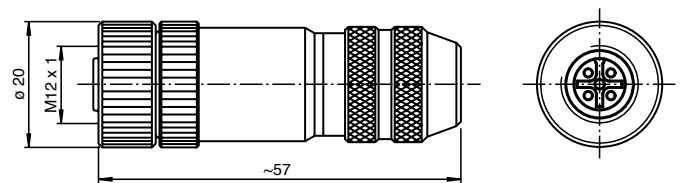

#### V15SB-G

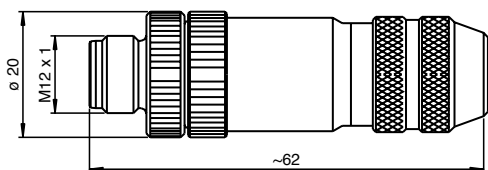

### Specifications for PROFIBUS Raw Cable

MATERIAL DATA	
Cable Type	Purple PVC, PLTC
Cable Outer Diameter	8 mm
ELECTRICAL DATA	
Baud Rate	Max 12 Mbps
Conductor	Solid
Voltage Rating	300 V
ENVIRONMENTAL DATA	
Temperature Range	-40° to +221°F (-40°C to +105°C)

CONTINUED

# RFID Accessories

## PROFIBUS Accessories (cont.)

### Specifications for PROFIBUS D-Sub Connector (VAZ-PB-DB9-W)

MATERIAL DATA	
Body	Metal plated ABS
Cable Diameter	Accepts cables from 7.6 mm...8.4 mm DIA
Termination	Yes, switchable
ELECTRICAL DATA	
Baud Rate	Max 12 Mbps
Current Rating	4 A
Voltage Rating	125 VDC
ENVIRONMENTAL DATA	
Protection Class	IP40
Temperature Range	-4° to +158°F (-20°C to +70°C)

### Wiring and Dimensions (mm)

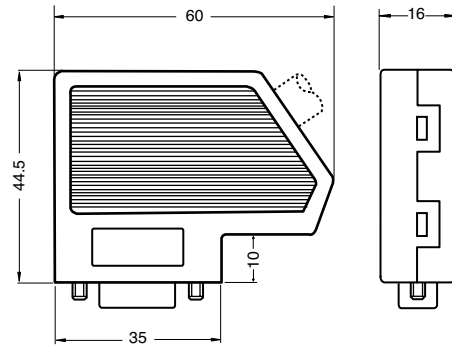
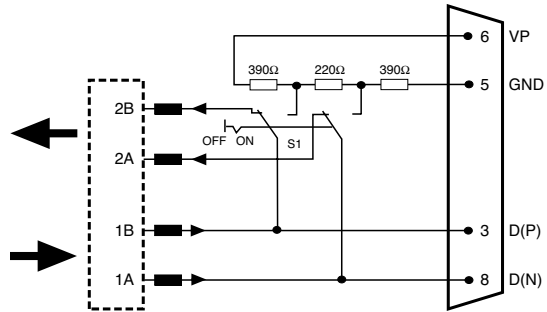

## Mounting Accessories

### Adjustable Bracket

Brackets are available for all diameter cylindrical read/write heads. Made of tough Crastin, the mounting bracket simplifies mounting and read/write head adjustment. Order bracket by model number shown.

Model No.	Read Head Dia.	A	B	C	D	E	F	Slot Width	Mounting Screws
BF18	18 mm	30	44	24	18	40	26	5.5 mm	#10-24
BF30	30 mm	40	56	36	30	40	24	5.5 mm	#10-24

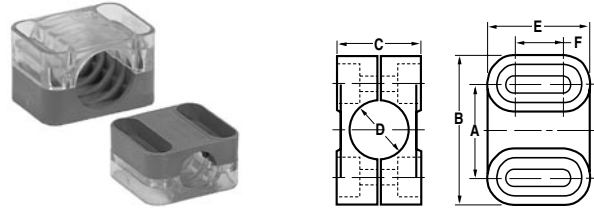

### Right Angle Bracket

Angle brackets are available in three diameter sizes and made of stainless steel. Read/write heads can be adjusted by using lock nuts supplied with sensor. Order by model number shown.

Model No.	A	B	C	D	E	F	G	H	I	J	K
AB-18	19.05	34.92	17.46	19.84	38.10	22.22	6.35	4.76	25.40	5.56	3.17
AB-30	30.96	50.80	25.40	36.91	63.50	31.75	9.52	6.35	38.10	9.52	3.17

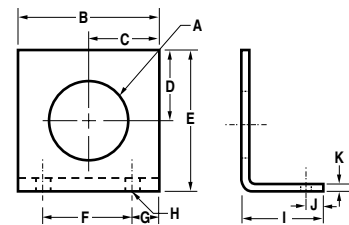
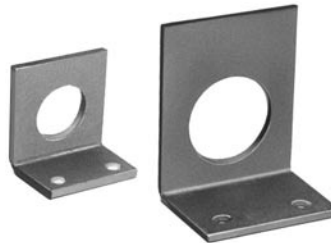

CONTINUED

## Mounting Accessories (cont.)

### Universal Bracket

The BF5-30 handles standard sensor sizes from 5 mm to 30 mm in diameter and provides 360° rotation in 2 axes

Model	Description
BF5-30	2 axes, adjustable bracket for cylindrical heads

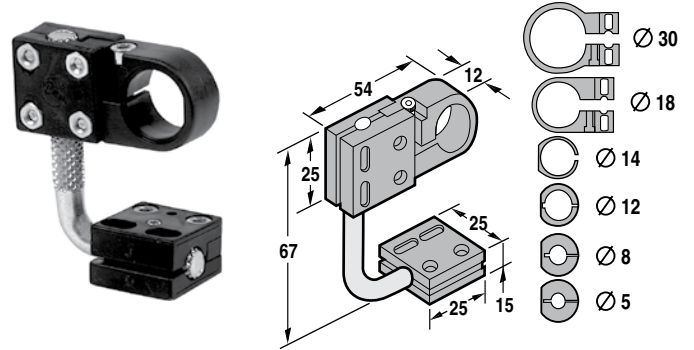

### RAM Mounts

Model	Description
RAM-2461-Y906430	Mounting plate for flat pack style (ex. IPH-FP-V1) read/write heads
RAM-101U	Adjustable RAM mounting arm
RAM-200-1	Adjustable RAM mount with 1/2" NPT entrance



RAM-2461-Y906430

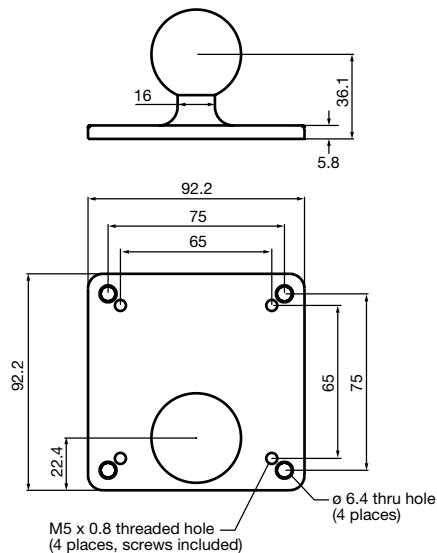

RAM-101U

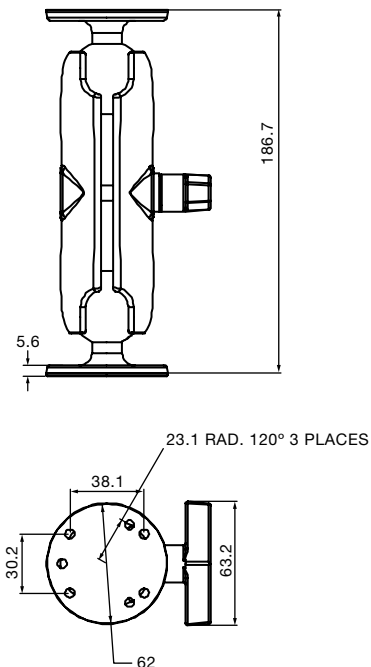

# RFID Accessories

## Tag Accessories

### Protective Covers

Protects tags from mechanical damage and weld slag.  
Rated for -40F° to +302°F (-40°C to +150°C)

Model	Description
ICS-30GK	Delrin cover for 30 mm tags
MVC-SH1	POM cover for MVC-... tag



### Mounting Tools

For mounting 16 mm and 30 mm threaded tags

Model	Description
IVZ-16GK-EW	Mounting tool for 16GK tags
IVZ-30G-EW	Mounting tool for 30GK tags



### Mounting Spacer

Plastic spacer to mount any tag directly on metal

Model	Description
IPZ-MH50	7 mm spacer, 50 mm diameter

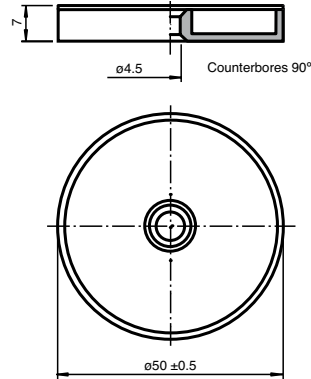
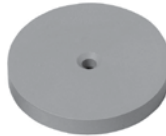



## Handheld Accessories

### ODZ-MAH200-GRIP Pistol Grip

For those who prefer gun-style handhelds, the ODZ-MAH200-GRIP is a clip-on pistol-grip handle. The handle is lightweight, simple to attach, durable, and performs extremely well in multiple drop tests.

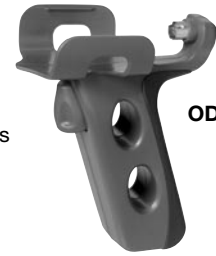

ODZ-MAH200-GRIP

### ODZ-MAH-GRIP1, ODZ-MAH-GRIP2, ODZ-MAH-GRIP3 Rugged Pistol Grips

Designed for rugged operation, these grips withstand harsh conditions in high-use environments. GRIP1 is used with the USB, RS-232, or PS/2 interconnect cables (see below). GRIP2 and GRIP3 offer a new level of cordless mobility in demanding applications. GRIP 2 comes with a standard-capacity battery, while the GRIP 3 has a high-capacity battery system.

#### Features:

- Extended trigger life: three million activations
- Screw attachment option to secure reader to handle
- Optional cable attachment clip to secure cable to handle
- Elastomer overmold improves drop-shock survivability
- Accommodates optional lanyard attachment to connect to belt or hook



ODZ-MAH-GRIP1



ODZ-MAH-GRIP2  
ODZ-MAH-GRIP3

Model Number	Description
ODZ-MAH-GRIP	Clip-on pistol grip (requires battery or battery blank and cable)
ODZ-MAH-GRIP1	Ruggedized cable handle (requires cable)
ODZ-MAH-GRIP2	Ruggedized battery handle, 1950 mAH*
ODZ-MAH-GRIP3	Ruggedized battery handle, 3900 mAH*

\*We continuously improve our products, consult factory for current mAH ratings.

### Interconnect Cables

The RFID handhelds are connected with an optional USB, RS-232, PS/2 or stand alone-power cable. The USB cable is 6 feet (1.83 meters) long. The RS-232 cable is a coiled 8 foot (2.43 meters) cable and is available with an optional power supply. The PS/2 cable is a 6 foot (1.83 meters) coiled cable. The stand-alone power cable is a 6 foot (1.83 meters) straight cable.



Model Number	Description
ODZ-MAH-CAB-B14	USB cable, 6 ft.
ODZ-MAH-CAB-B14-3.7M	USB cable, 12 ft.
ODZ-MAH-CAB-R2	RS-232 cable, 8 ft. (requires ODZ-MAH-5V-110V power supply)
ODZ-MAH-CAB-R6	PS/2 keyboard wedge cable, 8 ft.
ODZ-MAH-PWR-CABL	Charging cable (requires ODZ-MAH-5V-110V power supply)

### Batteries/Power Supplies

The RFID handhelds can use a high-capacity lithium ion battery, allowing you to operate the unit for more than a complete shift at the highest use rate.

A multi-function, 2-bay battery charger, charges the individual batteries. It has a charge indicator LED for each slot. Approximate charge time: 4 hours.

The ODZ-MAH-5V-110V is an external power supply to plug the unit into the wall.



Model Number	Description
ODZ-MAH-BAT	High-capacity battery, 1950 mAH*
ODZ-MAH-BLANK	Battery blank (order interconnect cable separately)
ODZ-MAH200-CHARGER	Battery charger
ODZ-MAH-5V-110V	5 VDC power supply

\*We continuously improve our products, consult factory for current mAH ratings.

# RFID Accessories

## Handheld Accessories

### Bluetooth Modem

The Bluetooth modem features a Bluetooth 2.4 GHz wireless transceiver enabling reliable, two-way communication and optional security between the reader and a host computer or system that supports keyboard, USB or serial input/output.

Simply plug the modem into your computer using the appropriate cable and the unit is ready. There is no need to load any drivers (including Bluetooth Manager drivers). The Bluetooth modem is a simple hardware solution for customers who wish to enjoy the benefits of cordless data collection without modifying existing applications or installing software. The radio firmware is easily upgradable.



#### Features:

- Bluetooth to keyboard, USB or serial input/output
- Seamless integration with RFID handheld
- Simple installation: simply plug-in the modem and start transmitting wireless data
- Extended range: reader to modem separation up to 100 m (300 ft)
- Mountable to working surfaces (four drilled holes in casing)

Model Number	Description
ODZ-MAH-B15	Wireless Bluetooth to USB, PS/2, or RS-232 (interconnect cable not included, see above)

#### Specifications for ODZ-MAH-B15

ELECTRICAL DATA	
Bluetooth Class	Class I Bluetooth radio
Frequency/Emission	2.4 GHz ISM band, frequency hopping spread spectrum (FHSS GFSK)
RF Data Rate	1 Mbps
Data Throughput	115 kbps maximum
Power Source	5 VDC (from USB, PS/2 or external supply)
Bluetooth Device	V1.2; SPP (Serial Port Profile) - Slave
ENVIRONMENTAL DATA	
Operating Temperature	+32°F to +158°F (0°C to +70°C)
Range/Distance	100 m (300 ft) - line of sight
Antenna	Internal

### Software

The CodeXML Router allows you to easily connect an RFID handheld reader to any PDA running a Windows Mobile or CE application that accepts keystroke data (e.g., Word, Excel, Notepad).

Model Number	Description
ODZ-MAH200-CODEROUTER	ODZ-MAH200-CODEROUTER software on CD





# Barcode Imaging Systems

<b>Barcode Imaging Systems Selection Guide.....</b>	<b>98-101</b>
<b>Markets and Applications.....</b>	<b>102-104</b>
<b>Fundamentals of Barcode Imaging.....</b>	<b>105-108</b>
<b>Handheld/Portable Imagers .....</b>	<b>109-114</b>
<b>Fixed-Mount Imagers .....</b>	<b>115-130</b>
<b>Barcode Imaging Accessories.....</b>	<b>131-136</b>



## Handheld Imagers



**MAH200**



**MAH300**

<b>See Page</b>	111	111
<b>Highlights</b>	<ul style="list-style-type: none"> <li>• All common 1D &amp; 2D codes</li> <li>• 3 readings/s, omnidirectional</li> <li>• Wireless, USB, PS/2, serial Interface</li> </ul>	<ul style="list-style-type: none"> <li>• Keypad and display</li> <li>• All common 1D &amp; 2D codes</li> <li>• 3 readings/s, omnidirectional</li> <li>• Wireless, USB, PS/2, serial Interface</li> </ul>
 <b>1-D Barcode Symbolologies*</b>	Codabar, Code 11, 39, 93, 128, Interleaved 2 of 5, Matrix 2 of 5, Micro QR, MSI Plessey, Pharmacode, NEC 2 of 5, Postal Symbolologies (Postnet, Planet, Australian, Royal, Japan, KIX), RSS (Limited, Expanded, Truncated, RSS14, Stacked), Telepen, Trioptic, UPC/EAN/JAN	
 <b>2-D Barcode Symbolologies*</b>	Aztec, Codablock F, Composite, Data Matrix (ECC200), GoCode, Maxicode, Micro PDF417, MSI Plessey, PDF417, Pharmacode, QR Code, RSS Stacked	
<b>Reader Performance</b>		
<b>Focal Distance</b>	100 mm to 230 mm	100 mm to 230 mm
<b>Depth of Field</b>	-50 mm/240 mm	-50 mm/240 mm
<b>Field Size</b>	200 mm	200 mm
<b>Decoding Speed</b>	3 symbols/sec	3 symbols/sec
<b>Maximum Symbol Speed w/trigger</b>	Stationary reads only	Stationary reads only
<b>Operating Temperature</b>	+32 °F to +104 °F (0 °C to +40 °C)	+32 °F to +104 °F (0 °C to +40 °C)
<b>Storage Temperature</b>	-4 °F to +140 °F (-20 °C to +60 °C)	-4 °F to +140 °F (-20 °C to +60 °C)
<b>Communication</b>		
<b>Native</b>	USB, PS/2-Wedge, RS-232	USB, PS/2-Wedge, RS-232
<b>Keypad/Display</b>		Keypad, 128 x 128 Monochrome display
<b>Factory Installed Option</b>	Bluetooth	Bluetooth
<b>Using Network Adapter</b>	Ethernet (TCP/IP), Modbus/TCP, PROFINET, EtherNet/IP	Ethernet (TCP/IP), Modbus/TCP, PROFINET, EtherNet/IP
<b>VGA Live Image</b>	No	No
<b>Image Capture and Download</b>	VGA, SXGA	VGA, SXGA
<b>Trigger/outputs</b>		
<b>Inputs</b>	2 buttons (3 w/pistol grip)	2 buttons (3 w/pistol grip)
<b>Outputs</b>	Beeper, vibrate mode	Beeper, vibrate mode
<b>Model</b>		
<i>Cable/batch model</i>	<b>ODT-HH-MAH200</b>	<b>ODT-HH-MAH300</b>
<i>Wireless Bluetooth model (includes battery)</i>	<b>ODT-HH-MAH200-B15</b>	<b>ODT-HH-MAH300-B15</b>

\* We are continuously expanding solutions. Please consult the factory for symbolologies not listed.

# Handheld Interface Options and Accessories

## Interconnect Cables

Model Number	Description
ODZ-MAH-CAB-B14	USB cable, 6 ft.
ODZ-MAH-CAB-B14-3.7M	USB cable, 12 ft.
ODZ-MAH-CAB-R2	RS-232 cable, 8 ft. (requires ODZ-MAH-5V-110V power supply)
ODZ-MAH-CAB-R6	PS/2 keyboard wedge cable, 8 ft.
ODZ-MAH-PWR-CABL	Charging cable (requires ODZ-MAH-5V-110V power supply)



## Handles and Grips

Model Number	Description
ODZ-MAH-GRIP	Clip-on pistol grip (requires battery or battery blank and cable)
ODZ-MAH-GRIP1	Ruggedized cable handle (requires cable)
ODZ-MAH-GRIP2	Ruggedized battery handle, 1950 mAH*
ODZ-MAH-GRIP3	Ruggedized battery handle, 3900 mAH*

\*We continuously improve our products, consult factory for current mAH ratings.



## Batteries/Power Supplies

Model Number	Description
ODZ-MAH-BAT	High-capacity battery, 1950 mAH*
ODZ-MAH-BLANK	Battery blank (order interconnect cable separately)
ODZ-MAH200-CHARGER	Battery charger
ODZ-MAH-5V-110V	5 VDC power supply

\*We continuously improve our products, consult factory for current mAH ratings.



## Bluetooth Modem

Model Number	Description
ODZ-MAH-B15	Wireless Bluetooth to USB, PS/2, or RS-232 (interconnect cable not included, see above)



## Software

Model Number	Description
ODZ-MAH200-CODEROUTER	The CodeXML Router allows you to easily connect a MAH200 or MAH300 to any PDA running a Windows Mobile or CE application that accepts keystroke data (e.g., Word, Excel, Notepad).



## Mounting Brackets

Model Number	Description
ODZ-MAH200-BRACKET	Bracket/stand for ODT-HH-MAH200
ODZ-MAH300 BRACKET	Bracket/stand for ODT-HH-MAH300



See pages 131-136 for complete Barcode accessory listing.



# Fixed-Mount Imagers



**MAC340**



**MAC344**

<b>See Page</b>	122	123
<b>Highlights</b>	<ul style="list-style-type: none"> <li>• 6 m/s moving codes</li> <li>• 25 codes/s reading rate</li> <li>• Matchcode for QA monitoring</li> </ul>	<ul style="list-style-type: none"> <li>• Space-saving design</li> <li>• 6 m/s moving codes</li> <li>• 25 codes/s reading rate</li> <li>• Matchcode for QA monitoring</li> </ul>
 <b>1-D Barcode Symbologies*</b>	Pharmacode (Black & White), Code 39, Interleaved 2 of 5	
 <b>2-D Barcode Symbologies*</b>	Data Matrix (ECC200)	
<b>Reader Performance</b>		
<b>Focal Distance</b>	90 mm	32 mm
<b>Depth of Field</b>	±7 mm	±3 mm
<b>Field Size</b>	20 mm x 15 mm	29 mm x 24 mm
<b>Decoding Speed</b>	25 symbols/second	25 symbols/second
<b>Maximum Symbol Speed w/trigger</b>	6 m/s (for 16 x 16 Data Matrix, with 0.35 mm modules)	6 m/s (for 16 x 16 Data Matrix, with 0.35 mm modules)
<b>Maximum Decodable Data Capacity</b>	348 numerical, 259 ASCII, 172 bytes	348 numerical, 259 ASCII, 172 bytes
<b>Operating Temperature</b>	+32 °F to +104 °F (0 °C to +40 °C)	+32 °F to +104 °F (0 °C to +40 °C)
<b>Storage Temperature</b>	-4 °F to +140 °F (-20 °C to +60 °C)	-4 °F to +140 °F (-20 °C to +60 °C)
<b>Communication</b>		
<b>Native</b>	RS-232 (up to 115 K baud)	RS-232 (up to 115 K baud)
<b>Using P+F Device Server</b>	Ethernet (TCP/IP), Modbus/TCP	Ethernet (TCP/IP), Modbus/TCP
<b>VGA Live Image</b>	Yes	Yes
<b>Image Capture and Download</b>	VGA	VGA
<b>Trigger/outputs</b>		
<b>Inputs</b>	1 trigger (up to 4 optional)	1 trigger (up to 4 optional)
<b>Outputs</b>	1 (1 additional, optional)	1 (1 additional, optional)
<b>Model</b>		
<i>Base model</i>	<b>ODT-MAC340</b>	<b>ODT-MAC344-WHITE</b>
<i>Increased field of view</i>	<b>ODT-MAC340-INC</b>	
<i>High-resolution</i>	<b>ODT-MAC340-HD</b>	
<i>Optical character recognition</i>	<b>ODT-MAC340-OCR</b>	<b>ODT-MAC344-OCR</b>

\* We are continuously expanding solutions. Please consult the factory for symbologies not listed.



### MAC333

117

- All common 1D & 2D codes
- 3 readings/s
- Omnidirectional reading

Codabar, Code 11, 39, 93, 128, Interleaved 2 of 5, Matrix 2 of 5, Micro QR, MSI Plessey, Pharmacode, NEC 2 of 5, Postal Symbolologies (Postnet, Planet, Australian, Royal, Japan, KIX), RSS (Limited, Expanded, Truncated, RSS14, Stacked), Telepen, Trioptic, UPC/EAN/JAN

Aztec, Codablock F, Composite, Data Matrix (ECC200), GoCode, Maxicode, Micro PDF417, MSI Plessey, PDF417, Pharmacode, QR Code, RSS Stacked

100 mm to 230 mm

-50 mm/240 mm

200 mm

3 symbols/sec

Stationary reads only

+32 °F to +104 °F (0 °C to +40 °C)

-4 °F to +140 °F (-20 °C to +60 °C)

RS-232 (up to 115 K baud)

Ethernet (TCP/IP), Modbus/TCP

No

VGA, SXGA

1 trigger

1

### ODT-MAC333

## Network Adapters



	Ethernet	Ethernet
<b>See Page</b>	127	127
<b>Highlights</b>	<ul style="list-style-type: none"> <li>• Industrial network support</li> </ul>	<ul style="list-style-type: none"> <li>• Web page configuration, debug and mirror ports included</li> </ul>
<b>Number of Ports</b>	1	4, 8, or 16
<b>Communications</b>	RTS 1P DB9: TCP/IP RTS-UP-1: TCP/IP, EtherNet/IP, Modbus/TCP, PROFINET I/O, PROFINET CBA	Modbus/TCP, TCP/IP with PFT mode
<b>Addressable</b>	IP address, Subnet Mask, Gateway	
<b>Baud Rate</b>	10/100 Mbps	
<b>IP Rating</b>	IP20	
<b>Bus Connection</b>	RJ45	
<b>Model</b>	<b>RTS 1P DB9</b> <b>RTS-UP-1</b>	<b>RTS-4P-DB9</b> <b>RTS-8P-DB9</b> <b>RTS-16P</b>

## Cables and Interconnects

Model	Description
<b>ODZ-MAC-CAB-24V-R2-2M</b>	RS-232 to 15-pin + 24 VDC connector , 2.1 mm x 5.5 mm (center positive). No trigger input.
<b>ODZ-MAC-CAB-24V-R2-2M-V1-G-2M</b>	RS-232 to 15-pin, w/trigger connect (PNP), + 24 VDC connector 2.1 mm x 5.5 mm (center positive)
<b>ODZ-MAC-CAB-15POL-2.5M</b>	2.5 m 15-pin D-sub male/female extension cable
<b>ODZ-MAC-CAB-15POL-5M-FEMALE</b>	5 m 15-pin D-sub one end, unterminated other end
<b>ODZ-MAC-CAB-15POL-2.5M-FEMALE</b>	2.5 m 15-pin D-sub one end, unterminated other end
<b>ODZ-MAC-CAB-VIDEO</b>	MAC340/344 to VGA video cable
<b>VAZ-R2-STRT</b>	2 m 9-pin D-sub male/female extension cable

See pages 131-136 for complete Barcode accessory listing.

# Barcode Imaging for the Automotive Industry



In component manufacturing (emission, electrical, etc.) there are a great number of components that look similar, but have a totally different function. This permits the manufacturer to make products with different capabilities or for different models in the same assembly equipment. Two-dimensional barcoding provides a great solution with an assembly verification and tracking system. Labels on engine or drive train components contain build instructions, tolerance or surface information. They define the next step in the process, and ensure that the part is routed to the correct location for further assembly.

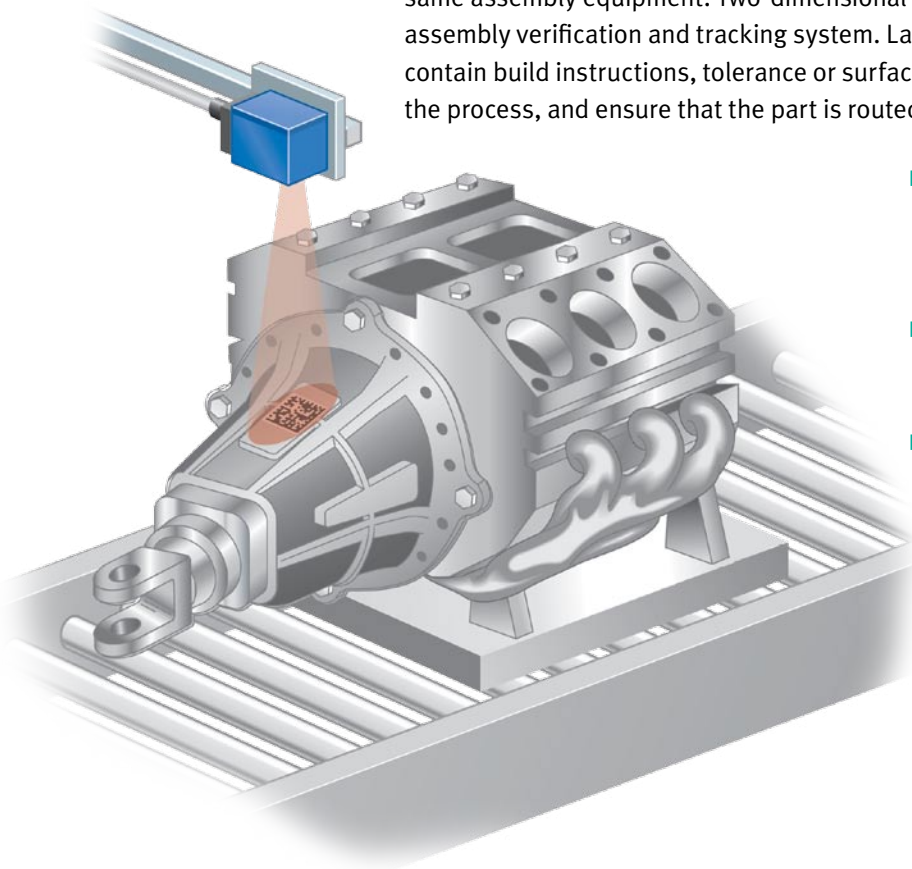

- **Verification**
  - Critical parts scanned
  - Verify correct parts used
  - Verify no parts are missed
- **Tracking**
  - Database of scanned parts
  - Traceability and audits
- **Permanent marking by DPM**



# Barcode Imaging for the Printing/Converting Industry



Barcode imaging greatly improves process speed and reduces error in mail inserting, sorting, and handling applications. High-speed inserters sequence and match mail pieces using barcodes. If a piece gets out of sequence, the barcode verification will stop the process. During sorting and handling, our high-speed imagers operate sorting equipment directly to verify that mail has been sent. When your printing business depends on speed, accuracy, and reliability, you need Pepperl+Fuchs high speed barcode imagers.

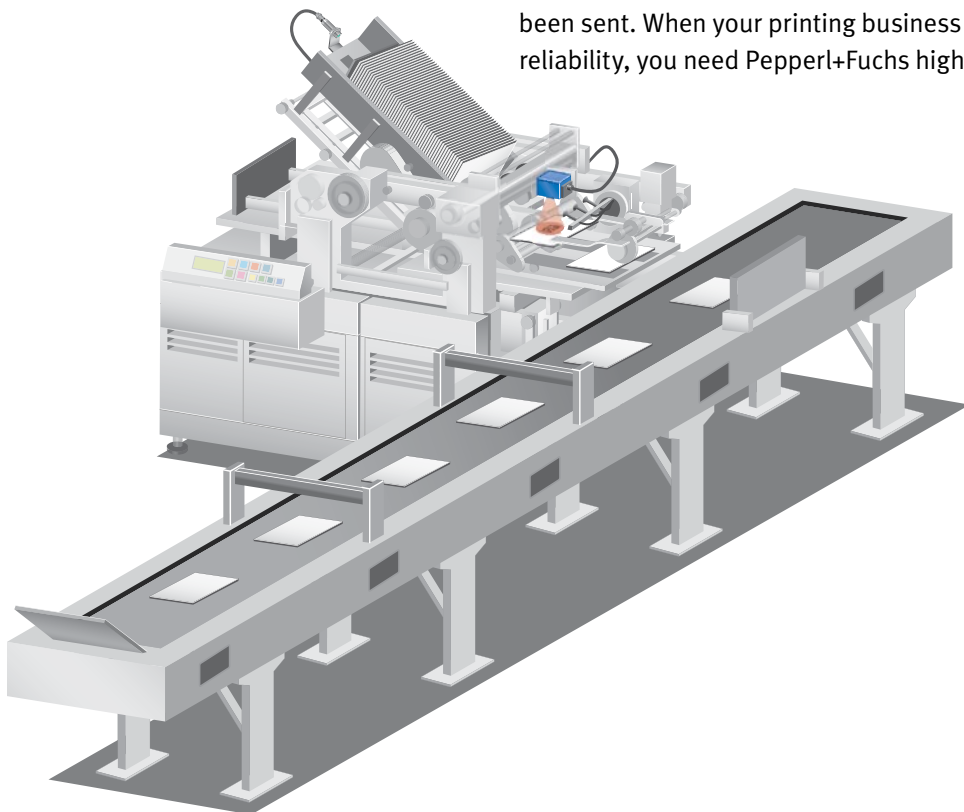

- Bulk Mail Facilities
- Mail Sorting
- Document Security

# Barcode Imaging for Packaging/Material Handling



## Packaging

Barcode imagers offer the capability to read a barcode and transmit that data or to make a go/no go decision when comparing the barcode information to a programmed reference code. Those products that do not match the reference code can be separated from the production line, ensuring 100% product identity.

- Product traceability through the supply chain
- Product authentication
- Tracking and control
- Routing and sorting
- Pharmacode and print-to-cut capability

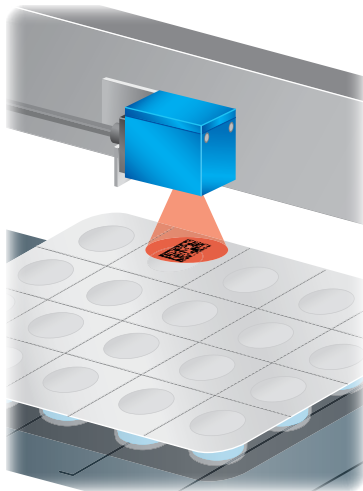

## Material Handling

Barcode imagers are used in all areas of the material handling industry. Whether you're using a wireless handheld for inventory control, reading barcodes on pharmaceutical packaging, or tracking products through the supply chain, Pepperl+Fuchs has a solution to meet your needs. Our products are built to exacting standards for reliable, repeatable, and trouble-free operation.

- Inventory control
- Traceability and auditing
- Tracking and control
- Routing and sorting

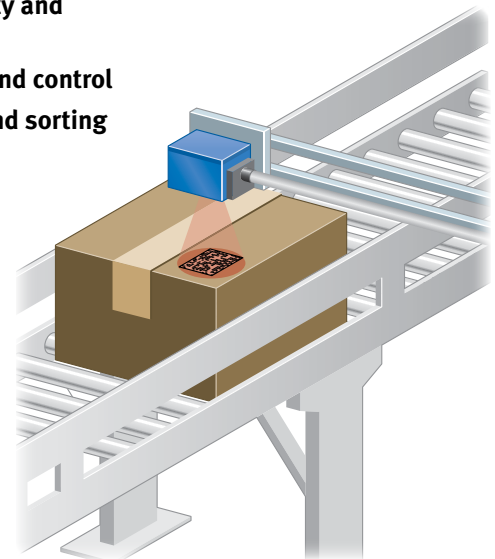

### Introduction To Data Matrix

Pepperl+Fuchs manufactures a broad range of barcode readers for a variety of applications. From collection of inventory data using wireless handhelds to high-speed readers capable of capturing rapidly moving packaging in an industrial environment, we have the right barcode imager for your application.

When it comes to barcodes, smaller is better. All Pepperl+Fuchs barcode imagers are capable of reading ECC 200 (Error Correction Code) Data Matrix symbology. ECC 200 is a very efficient two-dimensional (2-D) matrix barcode symbology that holds extensive data in a small footprint. By utilizing powerful Reed-Solomon error correction algorithms, ECC 200 allows error-free reading, even when a symbol is partially lost or destroyed.

An additional feature of Data Matrix symbology comes from its compact size. Because of their small size and large data capacity, Data Matrix symbols can be used to bring a data-file to a part or product. In this way, traceability or detailed information on a process is maintained with the component itself. It is no longer necessary to relate codes to a separately maintained database.

Our family of barcode imagers consists of handheld and fixed mount industrial units:

#### Handhelds

All units are capable of scanning 2-D barcodes (Data Matrix/ECC200, PDF417, QR, Aztec), all legacy 1-D bar codes plus RSS and Composite symbologies.

#### Fixed mount, stationary reading

All units are capable of scanning 2-D barcodes (Data Matrix/ECC200, PDF417, QR, Aztec), all legacy 1-D bar codes plus RSS and Composite symbologies.

#### Fixed mount, moving barcode

These products are compatible with Data Matrix/ECC200, Code 39, I 2 of 5 and Pharmacode symbologies.

### Applications And Markets

As additional information is stored with a part, 2-D barcodes are expected to replace many older barcode symbologies. The following example illustrates why higher data content is an important factor.

Imagine the assembly of a widget that uses an electric motor. Depending on the product specifications, several motors are available during the assembly. In the past, the process required the operator to scan the motor, enabling production control to verify that the operator assembled the product with, for instance, a 110 V motor. A part number is usually used to make this association. As the need for better product and quality tracing became apparent, many manufacturers added a second barcode with a part's serial number. Now it is possible to trace any problems to the lot or time of manufacture of the motor. This simple addition introduced several problems:

- Scanning two barcodes takes twice as long.
- Production control software must allow the operator to scan the codes in any order (part number first or serial number first). This introduces a new level of complexity and software testing.
- The size of the part may not allow placement of additional barcodes.
- Traditional barcodes do not offer data correction, resulting in more misreads as additional barcodes are placed on the product.

This scenario becomes even more complex as additional data is needed. A 2-D barcode, specifically the Data Matrix code, is the natural solution to those problems because:

- The symbol is small and offers high data density.
- It provides a fast, one scan operation.
- The sequence of the data (part number, serial number, etc.) is built into the symbol and, therefore, is always transmitted in the correct order, simplifying software development.
- Advanced error correction reduces the number of misreads and no-reads.

Transitioning from a traditional barcode-based approach to 2-D barcodes is unproblematic since our imaging systems read all common 1-D and 2-D barcodes. Users can grow into applications by first replacing old 1-D barcode readers with one of these models and then switching to the Data Matrix symbology as the application demands greater amounts of data or traceability.

### Aircraft OEMs, Customers & Suppliers

Due to industry standardization, use of 2-D barcodes is off to a great start. In the airline industry, SPEC2000 provides, airlines, airframe manufacturers, service facilities, etc. a platform from which they can provide:

- **Customer Receipt Process**  
Suppliers provide bar coding on the document/label/ tag for a shipment.
- **Repair Agency Receipt**  
Agencies process barcoded shipment labels designed for repair centers.
- **Permanent Parts Identification**  
Allows tracking of serialized parts throughout a products lifetime. These include provisioning, processing warranty claims, tracking part flight hours and landings, tracking part installation and removal time.
- **Traceability Data**  
Allows permanent parts traceability from beginning to end of a part's life.



# Barcode Imaging Systems

## Fundamentals of Barcode Imaging



### Automotive

AIAG (Automotive Industry Action Group) has been a pioneering organization in the development of many of the standard identification technologies in the automotive industry. They include barcode standards, parts ID and traceability standards, tire and wheel identification standards, and shipping label standards, to name a few. The 2-D barcodes are expected to replace many older barcode symbologies, as additional information must be

stored with a part. Items that are already tracked using Data Matrix symbology include airbags, engine blocks and engine parts, brakes and discs, mufflers, wheels, crankshafts and transmission parts.

Further, many occurrences of automobile parts theft could be eliminated with direct part marking (DPM) using Data Matrix symbology. Unlike printed labels, the symbology is permanent and cannot be easily removed from the components with DPM.

### Manufacturing

Any manufacturer that requires traceability (white-ware, computer chips, etc.) may use 2-D barcode technology. As stated earlier, migrating from traditional 1-D to 2-D barcode technology is a straightforward process. The goals of these projects may be:

- Reduce shop order build quantities
- Increase line yields
- Minimize nonvalue-added activities
- Reduce cost of nonconformance
- ISO 9001 certification process

2-D barcoding is a great solution for these situations. The component verification and tracking system provides the following:

- Verification
  - a. Critical parts scanned
  - b. Verify correct parts used
  - c. Verify no parts are missed
- Tracking
  - a. Database of scanned parts
  - b. Adds traceability capabilities



### OEM Machine Builders

The OEM market is typically driven by customer specifications. Reasons for using Data Matrix here are similar to other applications, namely, traceability and higher productivity. The following are some applications in this market:

#### Conveyor system builders/integrators

Conveyor builders and manufacturers of assembly machines will be required to provide systems compatible with 2-D & Data Matrix codes.

#### Label manufacturers

Labels are typically made of paper, plastic or metal. Any manufacturer of labels must have the ability to check them before sending them to their customers.

#### Pick and place system builders

Pick and place machines must identify the parts they are picking. The size of the Data Matrix symbols and high data integrity make this an ideal application.

#### PCB handling machines

When tracking PCB parts is required Data Matrix shines! The symbols can be very small, even rectangular. Rectangular symbols may be necessary when symbols are placed at the edge of the PCB.

The data file concept (large amounts of data being encoded into the symbology) provides the necessary information for the most complex of tractability requirements.

The built-in Reed-Solomon Error Correction provides a robust control system. This feature assures a good reading the first time and nearly every time and facilitates high-speed reading.

## Operating Principles

Unlike 1-D or stacked 2-D barcodes, data encoded in a Data Matrix symbol is not related to the absolute size or shape of elements within the matrix with respect to each other. It makes no difference if the module is round or square, as long as there is a change in contrast in the element, which can be resolved by the algorithm. This provides greater latitude in printing contrast and variation than can be accommodated in traditional 1-D symbology.

Data Matrix symbols include the following elements:

#### • Finder

The reader uses the L-shaped finder pattern to determine the orientation of the symbol.



#### • Alternating Pattern

Opposite the finder, the alternating pattern dictates the density of the data cells inside the code matrix and allows the reader to place



a “grid” over the system. Using this grid, the locations of black and white modules can be determined. This procedure makes it possible for a reader to evaluate symbols that are skewed. Perhaps more importantly, by placing the grid over the symbol the presence or absence of a black module is determined based on summing up (i.e., integrating) the amount of black. A sharp transition between a black module and a white area is not required.

- **Data Region**

The data region is enclosed by the L-shape finder patterns and the alternating pattern. It contains not only the data which has been encoded into the symbol but also includes redundant data according to the Reed Solomon algorithm to provide the forward error correction capabilities of this symbology.



- **Quiet Zone**

For the software algorithms of the reader to reliably find the symbol it must be surrounded by white space called the quiet-zone



ECC 200 symbols have an even number of rows and an even number of columns. Most of the symbols are square with sizes from 10 x 10 to 144 x 144. Depending upon the application, (to minimize the effect of printing on curved surfaces, or to print along the narrow edge of a circuit board) symbols can also be rectangular.

Data Matrix symbology occupies approximately 30% of the space of a traditional barcode. The only limitation is the resolution of the printing or imaging technique.

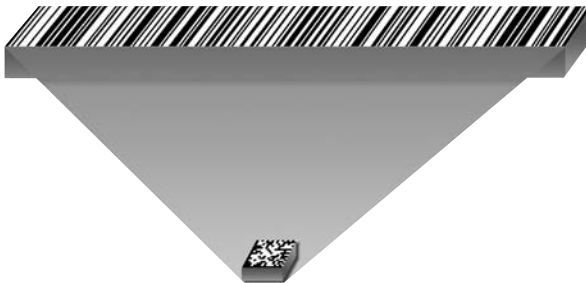

### Omnidirectional Reading

The fundamental design of the Data Matrix symbology provides omnidirectional readability. As discussed earlier, the symbology incorporates a finder pattern that consists of two solid bars oriented 90° at the boundaries of the symbol. Across from this at the other edges, is an alternating pattern.

With these two considerations, we can print a rectangular symbol axially along a cylinder (bottle, vials, etc.) and present much less optical deformation of the symbology. This greatly enhances the readability of the code, especially at high speeds.

### Forward Error Correction

Data Matrix codes use a highly developed Reed Solomon error correction algorithm. This process has been successfully used

for many years. By using mathematical redundancy, where extra data is incorporated into the symbol, read errors can be first recognized and then corrected (up to a certain number of errors). Thus, Data Matrix symbols can be still read even if a portion of the image is obscured or damaged.

### Sorting or Reading

A barcode imager can offer the capability to read a barcode and transmit that data or make a go/no go decision internally. In the latter, an internal comparison function examines the agreement of a barcode that has been read with a programmed reference code; ensuring 100 percent identity in a manufacturing process (e.g., Pharmaceutical). Those products not matching the reference code can be separated from the mainstream product. In addition, the data that has been read can be transmitted over the interface. An example of this control is a sequential serial number in the production process.

### Applications

Today, Data Matrix symbology finds its way into many diverse applications.

Due to its space-saving capabilities, it is possible to replace legacy 1-D barcodes in an area that is a fraction of the original size, while bringing additional data and integrity to the application.

On the other hand, completely new applications are now possible due to the nature of the symbology. It is possible to laser etch orpeen these symbologies into metal or plastic surfaces as printing a paper label is no longer a limitation of the technology.

In this way, the symbology becomes a permanent part of the product throughout its lifetime.

### Barcode Basics

Since the invention of barcodes, this technology has seen constant change and improvements. Between 1970-80 many important standard symbologies were developed and introduced, most are still used today. These different code symbologies were developed to address the specific needs of target industries. The following sections on 1-D and 2-D symbols list a few reasons for (and against) using one type over another.

### Common 1-D Barcode Symbols

1-D barcodes are used in every conceivable industry and application. The number of existing codes is quite large, allowing users to select the coding mechanism that fits the application. However, users must consider those advantages and disadvantages beforehand. The good news is that most of the available 1-D barcode readers are able to read most (if not all) of these codes. We are only going to mention a few codes, list reasons for using them, and possible problems. Common to all codes is the “Start” and “Stop” symbol. These symbols allow the reader to determine a unique direction, making it possible to read from “left-to-right” and “right-to-left.”

# Barcode Imaging Systems

## Fundamentals of Barcode Imaging

### 2-D “Barcodes”

The need to store more information using barcodes resulted in the introduction of 2-D solutions. Starting in the late 1980s “stacked” codes were introduced. These codes are composed of a number of 1-D codes stacked above each other. The resulting code is then placed between a common “Start” and “Stop” symbol. Later new symbologies were developed, most of which require a “camera” based reader.

### Common 2-D Symbologies

#### Codablock

Two variants (A and F (based on 128 barcode)) are used.

This code allows up to 44 individual code rows resulting in a maximum of 2725 data symbols. They are readable with “standard” line scanners. The common “Start” and “Stop” portion is seen in this example.

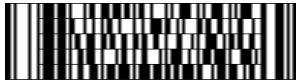

#### Maxicode

Maxicode is a public domain 2-D symbology currently employed by UPS in package sorting. The major drawback is its fixed physical size (1” by 1”) and fixed data content.

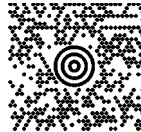

#### PDF 417

PDF 417 is a compact code with high information density. The code includes Reed-Solomon forward error correction. It was originally developed by Symbol Technologies.



#### Data Matrix

Data Matrix is a 2-D symbology that has grown significantly over the last 5 years. The strength of Data Matrix is due to several factors that give this symbology significant advantages in everyday applications:



### Scalability

Data Matrix code is fully scalable. As long as a reader can capture the image, and resolve the modules, any size is possible. The two symbols on the right contain the exact same information, One is scaled to several inches square. The smaller one is less than 3/8” on each side. Smaller symbols are possible as long as the printing process offers enough resolution and the “ink dots” remain well defined on paper. Direct laser marking can generate the smallest symbols, as it does not involve any additional transfer processes. Laser printers use a laser to transfer the image onto a printing drum. This changes the electrostatic properties of the drum, and the ink powder sticks to the drum creating a positive of the image. The powder is then transferred to the paper and heated.



Reading symbols over such a wide size range is possible since Data Matrix readers are not looking for edges (between white and black) and the width between the bars and white areas. Instead, the evaluation algorithm places a virtual grid over the recorded symbol and then looks for “dots” at the grid intersections. “Dots” are found by adding up the blackness around the grid intersections. This leads to fewer requirements on the print process and edge contrast is not critical. Consequently, many print methods can be used successfully.

This is a good time to clarify the meaning of symbol size versus symbol dimension. The size of a symbol is counted in modules and determines how much information can be stored in the symbol. The symbol dimension is its actual size in millimeters or inches. Given a certain symbol size (amount of information) the resolution of the printing process sets a lower limit for the symbol dimension.

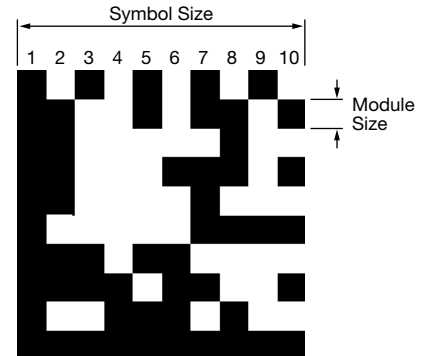

### Data Integrity & Forward Error Correction

Data Matrix ECC200 symbols are not scanned, but read via an imaging system. Usually, the recorded image is evaluated by a powerful DSP (Digital Signal Processor) or other microprocessor, and the resulting information is sent to a number of different communication interfaces (RS-232, USB, etc.).

Data Matrix Symbology employs Reed-Solomon error correction. Forward error correction means that symbols can be partially destroyed and the algorithm is able to correctly read all stored information. This is possible since the data on the symbol is stored with a certain amount of redundancy. Forward error correction is not a retry method. An image is taken once and decoded once. This error correction method is also used on CDs and DVDs.

The following example shows how humans perform just such forward error correction when reading text. Language (like Data Matrix codes) contains redundant information and the brain can “fill in the blanks” as long as not too much information is missing. An advertising campaign by a well-known hotel chain read as follows:

FR HI-SPD INT SNDS MSGS FASTR

After looking at this for a bit, you will have no problem identifying the real sentence to be:

Free high-speed internet sends messages faster

Counting the number of letters and spaces in both cases (29 and 46 respectively) we can say that the “full sentence” is about 40% redundant. The error correction algorithm used with Data Matrix symbols is very powerful and offers error correction rates that are approximately



# Handheld/ Portable Imagers

**Overview ..... 109**  
**MAH200/MAH300 ..... 110-114**

## Overview

The MAH200 and MAH300 are a family of revolutionary, new camera-based barcode imagers. Developed to be the first universal imagers, no other single device performs as many functions. With a cost far less than comparable systems and incorporating a unique dual path optical system, a 1.3 million-pixel CMOS sensor, and a 400 MHz processor, this combination has created a reading system that supports:

- High-density matrix codes and larger low-density linear codes
- Superior working range
- High-speed omnidirectional decoding
- Cordless and cabled interfaces
- Flexible configuration settings

They are smaller and lighter than comparable systems yet can withstand multiple drops onto a concrete floor. It is the only product available in *handheld*, *gun handle*, and *presentation* form factors with cabled, batch and cordless options. The cordless versions utilize the latest Bluetooth™ Class 1 interface with a 300-foot operating range. Rugged and lightweight, they will operate for more than a complete shift at the highest use rate on a single charge.

Whether you need a small, palm-held device or a traditional gun, the MAH200 and the MAH300 are specifically developed to enable users to easily choose the device that best meets their needs.

A high-capacity lithium ion battery supports portable operations. The 2.4 GHz radio system is available and compatible with a wide range of Bluetooth systems, as well as the CodeXML Modem, with a unique data and pairing encryption system for unsurpassed wireless data security. In addition, the MAH300 incorporates a battery-backed, real-time clock for time stamping critical data.

The MAH200 and MAH300 instantly read large linear, as well as high-density matrix symbols due to our unique Dynamic Optimization Technology (DOT). DOT continuously adapts the resolution, illumination, and image field for the fastest automatic symbology identification and decoding over the widest range of symbology types, sizes, recording surfaces and ambient lighting. With DOT, the MAH300 achieves matrix symbol decoding at speeds similar to linear bar code decoding, while preserving battery energy. By monitoring each user's reading patterns, DOT reduces training time and eliminates the need for manual configuration optimization through parameter settings.

The MAH300, Portable Data Terminal combines the already powerful features of the MAH200 with a graphic display and rugged keypad for local data entry and verification.

The MAH200 and MAH300 series handheld bar code readers are available in several configurations to meet your specific application requirements. Choose the most appropriate option, if your application changes in the future, you can order an accessory to meet the needs of your new requirements.

## MAH200/MAH300 Handheld/Portable Imagers

- Reads high-density matrix codes and larger low-density linear codes
- Superior working range
- Fast omnidirectional decoding
- Cordless and cabled interfaces
- Flexible configuration settings

### MAH200 Barcode Imager

The MAH 200 handheld units are the first universal bar code reader that automatically discriminates between all major 2-D matrix and linear bar code symbologies, and performs more functions than any other single device of its type. They are rugged and versatile enough for the most demanding warehouse and production applications, yet rapid and economical enough for point-of-sale applications. The MAH200 series handheld barcode imager is specifically developed to enable you to easily choose the device that best meets your needs. These units are available in two basic configurations to meet your application requirements:



#### • Cable and Batch Configurations

Using an optional USB, RS-232 or keyboard wedge cable, the MAH200 and the MAH300 interface to virtually any communication standard. All cables use rugged, automatic locking adapters that allow users to change cables, but prevent inadvertent disconnections.

Using an optional high-capacity lithium-ion battery, the MAH200 and the MAH300 can be used in a batch mode untethered to a computer or power supply. With over 6000 scan storage capacity, plus more than eight hours of standby time, these units provide ample capacity to meet the requirements of a standard production shift. Connecting the unit via an optional USB or PS/2 cable not only provides a download link, but also automatically recharges the battery. (The RS-232 cable provides interconnection to the computer, but without charging capability. Order the transformer separately.)

#### • Wireless Bluetooth Configuration

The Class 1 Bluetooth interface with a 300-foot operating range communicates seamlessly with desktop and laptop PCs, PDAs, printers cell phones, point-of-sale devices, and LAN and WLAN routers. Units offer

a large 4 MB nonvolatile memory for data and user programs and the high-capacity battery provides enough power to operate the unit over a typical shift plus ample standby time.

A high-capacity lithium ion battery supports portable operations. The 2.4 GHz radio system is available and compatible with a wide range of Bluetooth systems, as well as the CodeXML Modem, with a unique data and pairing encryption system for unsurpassed wireless data security.

### MAH300 Portable Data Terminal

The MAH300 establishes a new benchmark for portable data terminals and hand held computers by combining the industry's best imaging technology with a graphic display and rugged keyboard to create the smallest and lightest full-featured bar code reading terminal on the market.



Using the same ergonomic platform as the MAH200, the MAH300 extends mobile all-symbology bar code reading to include information display and keyboard entry.

Like the MAH200, the MAH300 is available in two versions: Cabled/Batch and Wireless.

A 2.4 GHz radio system is available and compatible with a wide range of Bluetooth systems, as well as the CodeXML Modem, with a unique data and pairing encryption system for unsurpassed wireless data security. A high-capacity lithium ion battery supports the portable operations. In addition, the MAH300 incorporates a battery backed, real-time clock that is great for time stamping critical data.

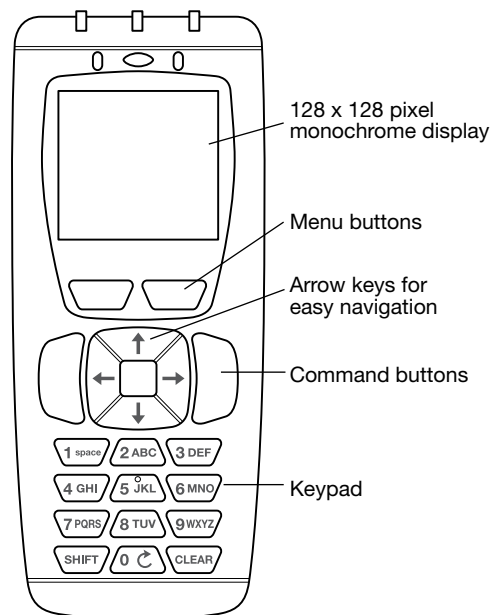



# Barcode Imaging Systems



Handheld/Portable Imagers MAH200/MAH300

MODEL	ODT-HH-MAH200	ODT-HH-MAH200-B15	ODT-HH-MAH300	ODT-HH-MAH300-B15
<b>SYMBOLOLOGY*</b>				
<b>1-D Barcodes</b>	Codabar, Code 11, 39, 93, 128, Interleaved 2 of 5, Matrix 2 of 5, Micro QR, MSI Plessey, Pharmacode, NEC 2 of 5, Postal Symbolologies (Postnet, Planet, Australian, Royal, Japan, KIX), RSS (Limited, Expanded, Truncated, RSS14, Stacked), Telepen, Trioptic, UPC/EAN/JAN			
<b>2-D Barcodes</b>	Aztec, Codablock F, Composite, Data Matrix (ECC200), GoCode, Maxicode, Micro PDF417, MSI Plessey, PDF417, Pharmacode, QR Code, RSS Stacked			
<b>READER PERFORMANCE</b>				
<b>Focal Distance</b>	100 mm to 230 mm			
<b>DOF</b>	-50 mm/240 mm			
<b>Field Size</b>	200 mm			
<b>Minimum Module Size</b>	0.15 mm			
<b>Maximum Symbol Size</b>	Square: 144 x 144 modules, rectangular: 16 x 48 modules			
<b>Decoding Speed</b>	3 symbols/sec			
<b>Max. Symbol Speed w/Trigger</b>	Stationary reads only			
<b>Max Decodable Data Capacity</b>				
<b>Operating Temperature</b>	+32°F to +104°F (0°C - 40°C)			
<b>Storage Temperature</b>	-4°F to +140°F (-20°C - 60°C)			
<b>IMAGE COLLECTION ENGINE</b>				
<b>Type</b>	Progressive scan CMOS			
<b>Chip Size</b>				
<b>Pixels</b>	1024 x 1280 (Near-field lens: 1024 x 640, Far-field lens: 1024 x 640)			
<b>Resolution/Gray Scale</b>	8-bit/256			
<b>Image Recording</b>				
<b>Processor</b>	AMD Alchemy CPU, 400 MHz			
<b>COMMUNICATION</b>				
<b>Native</b>	USB, PS/2, RS-232			
<b>HID (Keypad/Display)</b>	-		Keypad, 128 x 128 monochrome display	
<b>Factory Installed Option</b>	-	Bluetooth	-	Bluetooth
<b>Using P+F Device Server</b>	Ethernet (TCP/IP), Modbus/TCP, PROFINET, EtherNet/IP			
<b>VGA Live Image</b>	No			
<b>Image Capture And Download</b>	VGA, SXGA			
<b>MECHANICAL</b>				
<b>Interface Connection</b>	Communication interface specific			
<b>Power Connection</b>	Battery or wired	Battery	Battery or wired	Battery
<b>IP Rating</b>	IP20			
<b>Housing Material</b>	PCABS			
<b>Weight</b>	≈71 g		≈112 g	
<b>ELECTRICAL</b>				
<b>Operating Voltage</b>	5 VDC		5 VDC	
<b>Operating Current</b>	310 mA		400 mA	
<b>Inputs</b>	2 buttons (3 w/pistol grip)			
<b>Outputs</b>	Beeper, Vibrate Mode			

\*We are continuously expanding solutions. Please consult the factory for symbologies not listed.

# Barcode Imaging Systems

## Additional Information

### Decode Zones

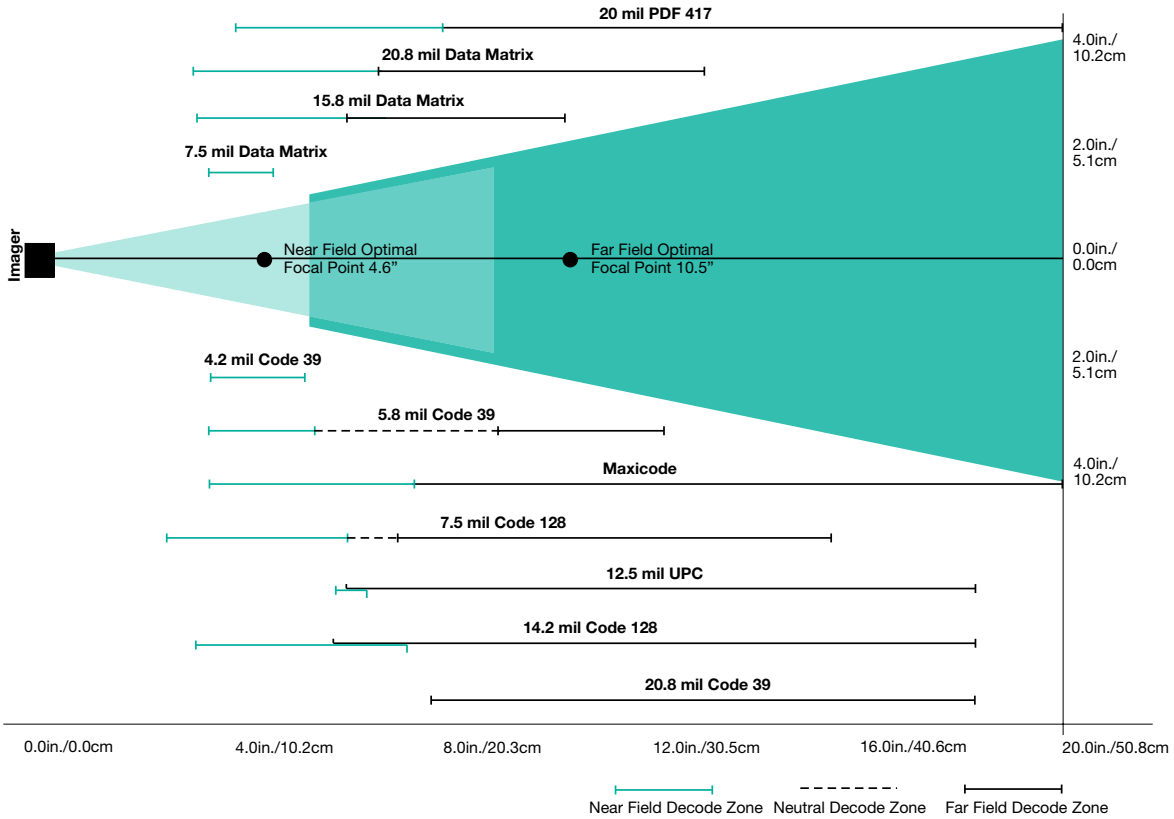

## Scanning in QuickConnect Codes

Pepperl+Fuchs makes it easy to quickly link the MAH200 or MAH300 handheld imagers to Bluetooth-enabled devices. The QuickConnect Generator on our website creates a small Data Matrix code to be placed on a Bluetooth device. When the code is scanned, the imager will connect with the Bluetooth device.

If you received your product from us, it will already have a QuickConnect code on the product label. If you did not get your product from P+F, before we can create a code that links your MAH200 or MAH300 to a Bluetooth device, we need to know the Bluetooth address (often referred to as the BD\_ADDR) of that device. You can locate the 12-character Bluetooth address on the device near the serial number. It may also be located in the Bluetooth setup section of your Pocket PC. Your name, e-mail and BD-ADDR are required to obtain a QuickConnect Code.

The website defaults to RF Two Way communication mode and 300 dpi printing. These are the best settings and should not be changed.

<http://www.am.pepperl-fuchs.com/quickconnect/code.jsp>

After scanning the QuickConnect Code you may want to make this setting permanent. To do so scan the Save Settings symbol below.



## Additional Information

### Reader ID and Firmware Version

To find out the Reader ID and firmware version, open a text editor program (i.e., Notepad, Microsoft Word...) and read the following code:



Note: For units with a Bluetooth Radio, the Reader ID is also your Bluetooth Radio PIN #.

### Reader ID and Firmware

You will get a text string with your firmware version and MAH300 ID number (see below):

Xap/IVVVVVVVVWXXXXSSSSSSSSSPXXX-XX+XX

Xap/I	Internal ID (not applicable)
VVV	Application firmware version number
WWWW	Bootloader firmware version number
XXXX	Radio firmware version number
SSSSSSSSSS	Reader's serial number (ten digits)
P	Is "A" if running firmware is the application, "B" if bootLoader
XXX-XX+XX	Internal ID (not applicable)

Example: Xap/i3000201206000010002363A06D-SD+SQ

## Dimensions (mm)

ODT-HH-MAH200

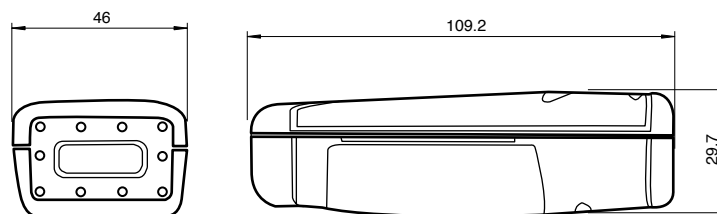

ODT-HH-MAH300

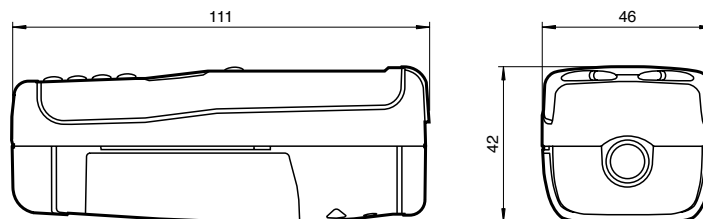

# Barcode Imaging Systems

## Accessories

### Handles and Grips

Model Number	Description
ODZ-MAH-GRIP	Clip-on pistol grip (requires battery or battery blank and cable)
ODZ-MAH-GRIP1	Ruggedized cable handle (requires cable)
ODZ-MAH-GRIP2	Ruggedized battery handle, 1950 mAh*
ODZ-MAH-GRIP3	Ruggedized battery handle, 3900 mAh*

\*We continuously improve our products, consult factory for current mAh ratings.



### Interconnect Cables

Model Number	Description
ODZ-MAH-CAB-B14	USB cable, 6 ft.
ODZ-MAH-CAB-B14-3.7M	USB cable, 12 ft.
ODZ-MAH-CAB-R2	RS-232 cable, 8 ft. (requires ODZ-MAH-5V-110V power supply)
ODZ-MAH-CAB-R6	PS/2 keyboard wedge cable, 8 ft.
ODZ-MAH-PWR-CABL	Charging cable (requires ODZ-MAH-5V-110V power supply)



### Batteries/Power Supplies

Model Number	Description
ODZ-MAH-BAT	High-capacity battery, 1950 mAh*
ODZ-MAH-BLANK	Battery blank (order interconnect cable separately)
ODZ-MAH200-CHARGER	Battery charger
ODZ-MAH-5V-110V	5 VDC power supply

\*We continuously improve our products, consult factory for current mAh ratings.



### Bluetooth Modem

Model Number	Description
ODZ-MAH-B15	Wireless Bluetooth to USB, PS/2, or RS-232 (interconnect cable not included, see above)



### Software

Model Number	Description
ODZ-MAH200-CODEROUTER	The CodeXML Router allows you to easily connect a MAH200 or MAH300 to any PDA running a Windows Mobile or CE application that accepts keystroke data (e.g., Word, Excel, Notepad).



### Mounting Brackets

Model Number	Description
ODZ-MAH200-BRACKET	Bracket/stand for ODT-HH-MAH200
ODZ-MAH300 BRACKET	Bracket/stand for ODT-HH-MAH300



See pages 131-136 for complete Barcode accessory listing.

# Fixed-Mount Imagers



**Overview ..... 115**  
**ODT-MAC333 ..... 116-119**  
**ODT-MAC340/ODT-MAC344..... 120-125**  
**Network Adapters ..... 126-130**

## Overview

Selection of our fixed readers can be simplified depending on the application. Currently, we are offering several lines of stationary mount readers. These are:

- **ODT-MAC333** – where the codes are stationary
- **ODT-MAC340 & ODT-MAC344** – for those high-speed applications where marked products must be read quickly

In situations where the barcode is not moving or moving slowly the choice is the MAC333. It is our most inexpensive fixed mount imager and has the capability to decode most all symbology. In fact, its range is so extensive, it can read over 35 different barcode standards. We update our decoders regularly, so check with our Applications Engineering staff if you don't see your symbology listed in the specifications section of this catalog.

Our line of high-speed fixed readers coupled with different firmware and optics covers an extensive array of applications. Fundamentally, there are two different series of products, the MAC340 and the MAC344. At the functional level they are identical, however, fit and form vary in the two series. While the MAC340 is a single-box unit, the MAC344 is a space-saving two-piece design, which incorporates optics and illumination into one housing and the decoding electronics in a second enclosure that can be mounted remotely where space is less critical.

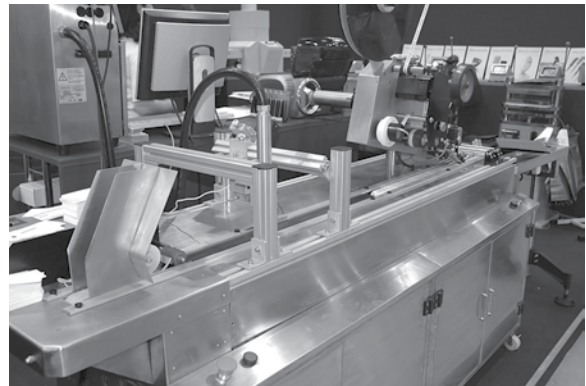

Both units are capable of reading ECC200 Data Matrix codes, Pharmacode, 39 and 1 2 of 5 codes. Both are configurable at the factory with optics to permit high-resolution imaging of extremely small 2-D codes and to facilitate larger fields of view, a lower resolution option.

On the firmware side, both series accept OCR firmware for optical character recognition. While available for all of the units, OCR makes most sense in the large field of view unit and, therefore, is the only unit actually called out in the catalog. For other configurations, please contact the factory.

## MAC333 Fixed-Mount Imagers

- Impressive operating ranges
- Small, yet extremely durable
- Reads stationary 1-D and 2-D codes
- Low cost, high resolution



The MAC333 incorporates the same internal optics and programming features as the MAH200 in a rugged aluminum industrial enclosure. This product is an ideal solution for industrial situations where barcodes are stationary and sequential product reads are made. It reads 2-D codes up to 4 readings per second and 1-D codes up to 6 readings per second. It is also a great solution for applications where all of the interface features of a handheld are not needed due to the fixed installation of the imager.

Same as the MAH200 and MAH300, the MAC333 incorporates a unique dual path optical system, a 1.3 million-pixel CMOS sensor, and a 400 MHz processor. This combination has created a reading system that supports:

- High-density matrix codes and larger low-density linear codes
- Superior working range
- High-speed omnidirectional decoding
- Fixed mounted, cabled interfaces
- Flexible configuration settings

### CMOS camera

The MAC333 uses a CMOS technology imaging system rather than a scanned laser beam, allowing cost-effective production and compact construction. The high resolution enables the acquisition of dozens of 1-D and 2-D codes (Data Matrix, PDF 417, MaxiCode, QR Code etc.).

Additionally, CMOS provides very robust omnidirectional reading capabilities. Codes can be read in a wide range of orientations or tilts and even if significantly distorted. With the built-in error correction algorithms provided in certain 2-D symbologies, the unit even reads codes that have a substantial portion of the symbol missing or obscured.

### Automatic adjustment

The MAC333 is user-friendly. Complicated parameter adjustments are not necessary. This imager automatically distinguishes between all major 2-D matrix and linear barcode symbologies and decodes them. Instructions and setup may be downloaded via the interface or programmed via scan codes.

### Rugged, compact, easy installation

The MAC333 is rugged and versatile enough for the most demanding production applications. The small size and wide adjustment range makes it ideal for nearly all mounting situations. A red laser-aiming pattern makes the installation easy and can be subsequently turned off once the installation is completed. A 15-pin D-Sub connector is used to route power and communication, as well as trigger input and outputs, to the unit. Plug it in, switch it on, and the MAC 333 is immediately ready to use!

# Barcode Imaging Systems



Fixed-Mount Imagers MAC333

<b>MODEL</b>	<b>ODT-MAC333</b>
<b>SYMBOLOLOGY*</b>	
<b>1-D Barcodes</b>	Codabar, Code 11, 39, 93, 128, Interleaved 2 of 5, Matrix 2 of 5, Micro QR, MSI Plessey, Pharmacode, NEC 2 of 5, Postal Symbolologies (Postnet, Planet, Australian, Royal, Japan, KIX), RSS (Limited, Expanded, Truncated, RSS14, Stacked), Telepen, Trioptic, UPC/EAN/JAN
<b>2-D Barcodes</b>	Aztec, Codablock F, Composite, Data Matrix (ECC200), GoCode, Maxicode, Micro PDF417, MSI Plessey, PDF417, Pharmacode, QR Code, RSS Stacked
<b>READER PERFORMANCE</b>	
<b>Focal Distance</b>	100 mm to 230 mm
<b>DOF</b>	-50 mm/240 mm
<b>Field Size</b>	200 mm
<b>Minimum Module Size</b>	0.15 mm
<b>Minimum Symbol Size</b>	2.75 mm x 2.75 mm
<b>Maximum Symbol Size</b>	Square: 144 x 144 modules, rectangular: 16 x 48 modules
<b>Decoding Speed</b>	3 symbols/sec
<b>Max. Symbol Speed w/Trigger</b>	Stationary reads only
<b>Operating Temperature</b>	+32°F to +104°F (0°C - 40°C)
<b>Storage Temperature</b>	-4°F to +140°F (-20°C - 60°C)
<b>IMAGE COLLECTION ENGINE</b>	
<b>Type</b>	Progressive Scan CMOS
<b>Chip Size</b>	1/3" (5.84 mm x 4.94 mm)
<b>Pixels</b>	1024 x 1280 (Near-field lens: 1024 x 640, Far-field lens: 1024 x 640)
<b>Resolution/ Gray Scale</b>	8-bit/256
<b>Image Recording</b>	Real-time or triggered
<b>Processor</b>	AMD Alchemy CPU, 400MHz
<b>COMMUNICATION</b>	
<b>Native</b>	RS-232 (up to 115k baud)
<b>Using P+F Device Server</b>	Ethernet (TCP/IP), Modbus/TCP
<b>VGA Live Image</b>	No
<b>Image Capture And Download</b>	VGA, SXGA
<b>MECHANICAL</b>	
<b>Interface Connection</b>	15-pin D-sub (comm & power)
<b>Power Connection</b>	15-pin D-sub (comm & power)
<b>IP Rating</b>	IP20
<b>Housing Material</b>	Aluminum
<b>Weight</b>	≈175 g
<b>ELECTRICAL</b>	
<b>Operating Voltage</b>	9 - 24 VDC +/-15%
<b>Operating Current</b>	100 mA
<b>Inputs</b>	1 trigger
<b>Outputs</b>	1 optoisolated

\*We are continuously expanding solutions. Please consult the factory for symbologies not listed.

## Wiring Diagrams

ODT-MAC333

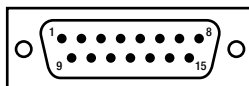

Sub-D Pinout	Signal
1	GND
2	GND
3	Trigger-GND
4	24+ V
5	24+ V
6	24+ V
7	RTS (RS-232)
8	Reserved

Sub-D Pinout	Signal
9	Output - Good
10	Output - Fail
11	Trigger Input
12	CTS (RS-232)
13	RXD (RS-232)
14	TXD (RS-232)
15	Reserved

# Barcode Imaging Systems

## Additional Information

Fixed-Mount Imagers MAC333

### Decode Zones

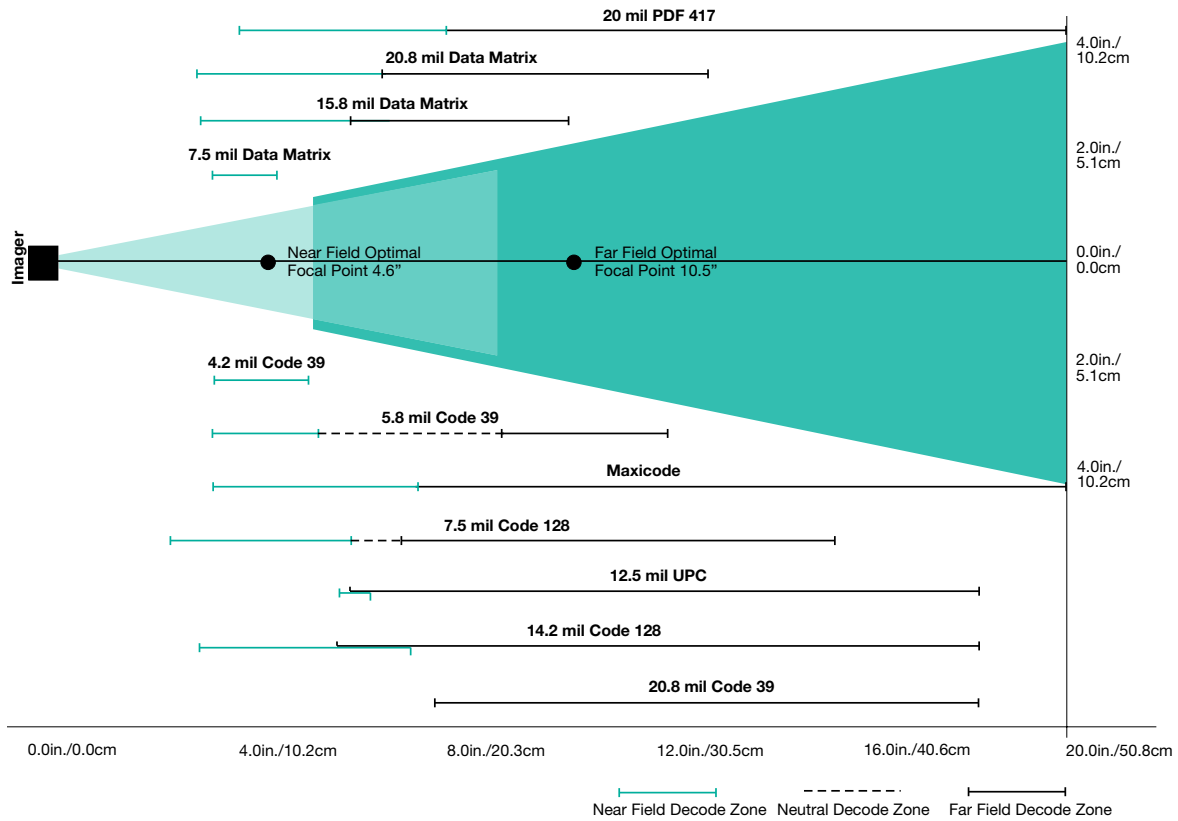

## MAC333 Serial Port Settings

The factory default serial port for the MAC333 is 57600, 8-bits, no parity, 1 stop bit. If there is any problem with communication, the following scan codes will reset the settings to facilitate communication via the serial port.

Syntax is [baudrate], [databits], [parity], [stopbits]. Factory default is 57600, 8, none, 1



M098\_01  
57600



M101\_01  
8



M103\_01  
none



M105\_01  
1

The unit is shipped from the factory in the continuous scan mode so that these codes may be read. If your unit is not in this mode and you cannot communicate with the serial interface to prompt a reading, it may be necessary to externally trigger the unit in order to gain control of the serial interface using the scan codes above.



## Dimensions (mm)

### ODT-MAC333

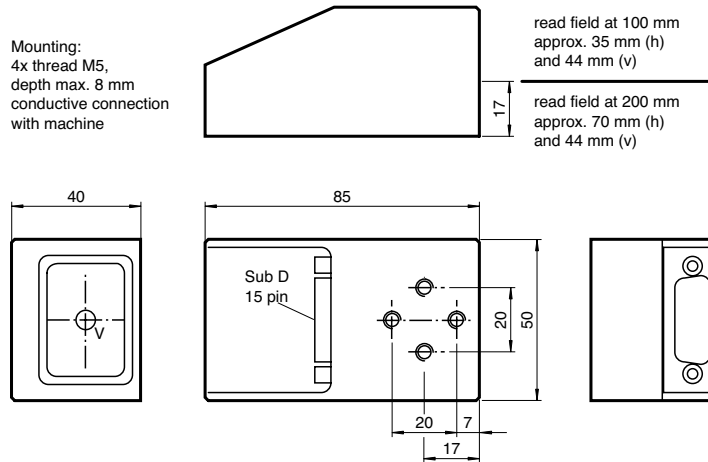

## Accessories

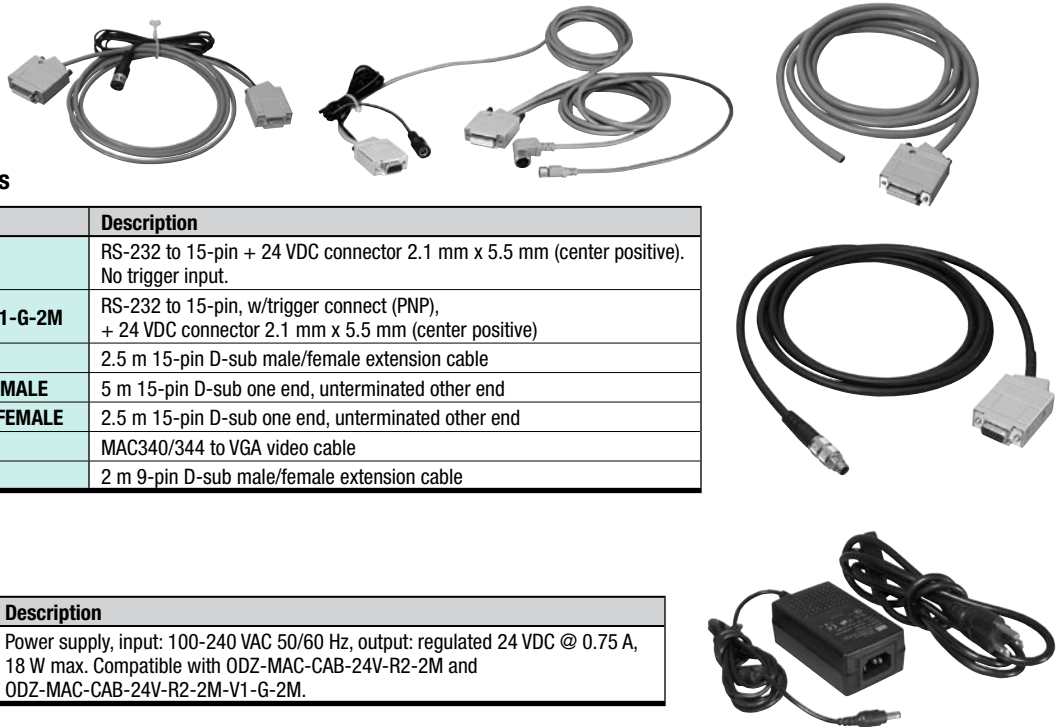

### Cables and Interconnects

Model	Description
ODZ-MAC-CAB-24V-R2-2M	RS-232 to 15-pin + 24 VDC connector 2.1 mm x 5.5 mm (center positive). No trigger input.
ODZ-MAC-CAB-24V-R2-2M-V1-G-2M	RS-232 to 15-pin, w/trigger connect (PNP), + 24 VDC connector 2.1 mm x 5.5 mm (center positive)
ODZ-MAC-CAB-15POL-2.5M	2.5 m 15-pin D-sub male/female extension cable
ODZ-MAC-CAB-15POL-5M-FEMALE	5 m 15-pin D-sub one end, unterminated other end
ODZ-MAC-CAB-15POL-2.5M-FEMALE	2.5 m 15-pin D-sub one end, unterminated other end
ODZ-MAC-CAB-VIDEO	MAC340/344 to VGA video cable
VAZ-R2-STRT	2 m 9-pin D-sub male/female extension cable

### Power Supply

Model	Description
ODZ-MAC-PWR-24V-110V	Power supply, input: 100-240 VAC 50/60 Hz, output: regulated 24 VDC @ 0.75 A, 18 W max. Compatible with ODZ-MAC-CAB-24V-R2-2M and ODZ-MAC-CAB-24V-R2-2M-V1-G-2M.

### Mounting Bracket

Model	Description
ODZ-MAC-BRACKET	Tabletop bracket, two axes

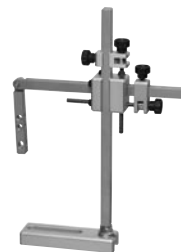

See pages 131-136 for complete Barcode accessory listing.

## MAC340/MAC344 Fixed-Mount Imagers

- Read up to 25 codes per second
- Read moving codes up to 6 m/s
- Space-saving design, a compact imaging head and separate evaluation box (MAC344)



The MAC340 and MAC344 read barcodes at very high transport speeds. The following performance data can be achieved with a Data Matrix code having a symbol size of 16 x 16 and a minimum module size of 0.35 mm:

- 25 evaluations per second
- 6 m/s transport speed of object
- Omnidirectional reading
- Progressive scanning
- Processing of 256 gray values; adaptive gray value threshold

### DSP performance

The digital signal processor (DPS) works in real time, providing a processing rate of approximately 150 million instructions per second. Decoding takes place in the imager and extensive external processing is not required. Data is presented in ASCII up to and including the maximum reading rate.

### Omnidirectional reading

Barcodes are read omnidirectionally. It is no longer necessary to read codes exclusively on the top or bottom of cylindrical objects (bottles, vials, cans, etc.). The code can be placed anywhere on the cylinder and will always be read as long as the image area is sighted. The finder pattern, a special feature in the Data Matrix code, allows the imager to determine the position and arrangement of the code.

### High ambient light immunity

The high-energy flash is precisely synchronized with the camera functions and the trigger signal. Only 27 microseconds are necessary to "freeze" the picture. The solid-state light source is not subject to deterioration. Heat generation and power consumption are reduced to a minimum.

### Flexible interface speeds data transfer

Fast production requires even faster data transmission. The imager may be programmed to send data in a variety of different protocols and with or without a custom prefix/suffix in order to meet your data requirements. It also achieves transfer rates of 115k baud under real conditions.

### Easy to adjust real-time video, no PC necessary

A VGA-monitor output is provided to connect a standard PC monitor. The image of the MAC340 can be displayed continuously and in real-time. In addition to the optical adjustment of the MAC340, the quality of the picture taken by the device can be precisely evaluated.

### Optical module rotates 90° (MAC340 only)

The mechanical adjustment of the MAC340 is very simple. The optical module, consisting of light source, optics and CCD chip can be turned 90° simply by loosening two screws. By rotating the module to the side window, the mounting height can be reduced and the cables can be installed parallel to the scanning surface.

### OMNICONTRON – Software for the user

OMNICONTRON for Windows (Windows 95 or higher) serves to alter the configuration. The program is designed to be user friendly and also offers various functions for error diagnosis. Once a set of parameters is chosen, this specific configuration may be stored in the PC or downloaded to the MAC340. Information remains in the nonvolatile memory until a different configuration is transmitted. For more detailed information, see the Fixed Mount Accessories section.

### QA production sorting

The MAC340 can transmit the acquired data via the serial interface. As an alternative, the Matchcode feature can be chosen. In this mode, the symbol is read and the value compared to a stored reference. Depending on the result, respective Good/Fail outputs are activated.

## MAC340/MAC344 Application-Specific Configurations

### MAC340-INC

#### Expanded read window barcode imager

For large imaging areas, we offer a version of the MAC340 with an increased field of view. The MAC340-INC provides an image area of 32 mm x 24 mm and the depth of focus increases to 10 mm. Other specifications remain the same, with the exception of minimum module size, which increases to 0.4 mm.

### MAC340-HD

#### High-resolution barcode imager

For small codes we offer a high-density unit. The MAC340-HD increases the optical magnification to facilitate reliable high-speed reading of very small symbologies. The minimum module size of this high-resolution reader is decreased from 0.17 mm to 0.10 mm. Commensurate with the increased magnification, the field of view is reduced to 11 mm x 8 mm and depth of focus is reduced +/- 5 mm.

### MAC340-OCR/MAC344-OCR

#### Optical Character Recognition

Like the MAC 340 and the MAC344, the MAC340-OCR and the MAC344-OCR are effective solutions for optical character recognition. While the MAC340-OCR is a

single-box unit, the MAC344-OCR is a space-saving two-piece design. Optics and illumination are attached via a 1.25 m cable to the electronic evaluation board in a separate housing. Only a 24 VDC power supply and a trigger are necessary to make each unit functional.

Any font can be memorized and stored in the internal memory. The powerful recognition software enables the imager to handle scaling of characters. This also makes difficult adjustment and calibration obsolete.

The DSP allows fast recognition of machine-marked characters and symbols. The evaluation time depends on number and size. The dimensions of the search window, the size of the stored font, as well as the number of active windows must also be taken in account.

The MAC340/344-OCR can be used in many applications. Up to 100 windows can be used with their individually assigned font and reading parameters. Flexibility is, therefore, almost unlimited.

## Wiring Diagrams

ODT-MAC340  
ODT-MAC344

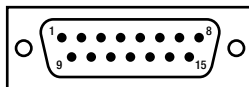

Sub-D Pinout	Signal
1	GND
2	GND
3	Trigger-GND
4	24+ V
5	24+ V
6	24+ V
7	RTS (RS-232)
8	Reserved

Sub-D Pinout	Signal
9	Output - Good
10	Output - Fail
11	Trigger Input
12	CTS (RS-232)
13	RXD (RS-232)
14	TXD (RS-232)
15	Reserved

Video Out:

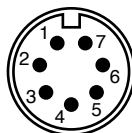

Pin Number	Signal
1	V Sync
2	GND
3	Red
4	Green
5	GND
6	Blue
7	H Sync

# Barcode Imaging Systems



## ODT-MAC340, Fixed-Mount Imager

MODEL	ODT-MAC340	ODT-MAC340-INC Increased Field of View	ODT-MAC340-HD High-resolution	ODT-MAC340-OCR Optical Character Recognition
SYMBOLGY*	Pharmacode (B&W), Data Matrix (ECC200), Code 39, I 2 of 5			OCR
<b>READER PERFORMANCE</b>				
Focal Distance	90 mm			
DOF	± 7 mm	± 10 mm	± 5 mm	± 7 mm
Field Size	20 mm x 15 mm	32 mm x 24 mm	11 mm x 8 mm	24 mm x 30 mm
Minimum Module Size	0.17 mm	0.4 mm	0.1 mm	0.17 mm
Maximum Symbol Size	48 x 48, rectangular 16 x 48			-
Min./Max. Symbol Size	3 x 3 mm/12 x 12 mm	6 x 6 mm/24 x 24 mm	2 x 2 mm/5 x 5 mm	-
Decoding Speed	25 symbols/second			10/second (includes image transfer)
Max. Symbol Speed w/Trigger	6 m/s (for 16 x 16 Data Matrix, with 0.35 mm modules)			4 m/s
Max. Decodable Data Capacity	348 num, 259 ASCII, 172 bytes			8 char, 1 line, 20 pixels
Illumination	Integrated, red or white LEDs	External, red LEDs standard		Integrated, red LEDs standard
Operating Temperature	+32°F to +122°F (0°C to +50°C), 95% RH, non-condensing to 50°C			
Storage Temperature	-4°F to +158°F (-20°C to +70°C)			
<b>VIDEO</b>				
Type	Progressive scan CCD			
Chip Size	1/3" (5.84 mm x 4.94 mm)			
Pixels	640 x 480			
Resolution/Gray Scale	8-bit/256			
Image Recording	Real-time or triggered			
Processor	DSP, 150 MHz, 1200 MIPS			
<b>COMMUNICATION</b>				
LED Display	3 LEDs, Trigger, Good Reading, Fail/No Read			
Native	RS-232 (up to 115k baud)			
Using P+F Device Server	Ethernet TCP/IP, EtherNet/IP, Modbus/TCP, PROFINET			
VGA Live Image	Yes			
Image Capture And Download	VGA			
<b>MECHANICAL</b>				
Interface Connection	15-pin D-sub (comm & power)			
Power Connection	15-pin D-sub (comm & power)			
Video Connection	Socket for VGA Monitor			
IP Rating	IP20			
Housing Material	Aluminum			
Weight	≈730 g			
Dimensions	65 mm x 84 mm x 132 mm			
<b>ELECTRICAL</b>				
Operating Voltage	24 VDC ± 15%			
Operating Current	210 mA	500 mA (max)		210 mA
Inputs	1 trigger (up to 4 factory installed options)			
Outputs	2 PNP, optoisolated			

\*We are continuously expanding solutions. Please consult the factory for symbologies not listed.

# Barcode Imaging Systems



## ODT-MAC344, Space-Saving Design, Fixed-Mount Imager

MODEL	ODT-MAC344-WHITE	ODT-MAC344-OCR Optical Character Recognition
<b>SYMBOLGY*</b>	Pharmacode (B&W), Data Matrix (ECC200), Code 39, I 2 of 5	OCR
<b>READER PERFORMANCE</b>		
Focal Distance	32 mm	32 mm
DOF	± 3 mm	± 3 mm
Field Size	29 mm x 24 mm	24 mm x 30 mm
Minimum Module Size	0.25 mm	-
Maximum Symbol Size	Square: 48 x 48; Rectangular: 16 x 48	-
Decoding Speed	25 symbols/second	10/second (includes image transfer)
Max. Symbol Speed w/Trigger	6 m/s (for 16 x 16 Data Matrix, with 0.35 mm modules)	4 m/s
Max Decodable Data Capacity	348 numerical, 259 ASCII, 172 bytes	8 char, 1 line, 20 pixels
Illumination	Integrated, red LEDs standard	
Operating Temperature	+32°F to +113°F (0°C to +45°C)	
Storage Temperature	-4°F to +158°F (-20°C to +70°C)	
<b>VIDEO</b>		
Type	Progressive scan CCD	
Chip Size	1/3" (5.84 mm x 4.94 mm)	
Pixels	640 x 480	
Resolution/Gray Scale	8-bit/256	
Image Recording	Real-time or triggered	
Processor	DSP, 150 MHz, 1200 MIPS	
<b>COMMUNICATION</b>		
Native	RS-232 (up to 115k baud)	
Using P+F Device Server	Ethernet TCP/IP, EtherNet/IP, Modbus/TCP, PROFINET	
VGA Live Image	Yes	
Image Capture And Download	VGA	
<b>MECHANICAL</b>		
Bus Connection	15-pin D-sub (comm & power)	
Power Connection	15-pin D-sub (comm & power)	
IP Rating	IP20	
Housing Material	Aluminum	
Weight	≈750 g	
Dimensions	39 mm x 49 mm x 85 mm	
<b>ELECTRICAL</b>		
Operating Voltage	24 VDC ± 15%	
Operating Current	500 mA	
Inputs	1 trigger (up to 4 optional)	
Outputs	2 PNP, optoisolated	

\*We are continuously expanding solutions. Please consult the factory for symbologies not listed.

Fixed-Mount Imagers MAC340/MAC344

# Barcode Imaging Systems

## Dimensions (mm)

Fixed-Mount Imagers MAC340/MAC344

### ODT-MAC340

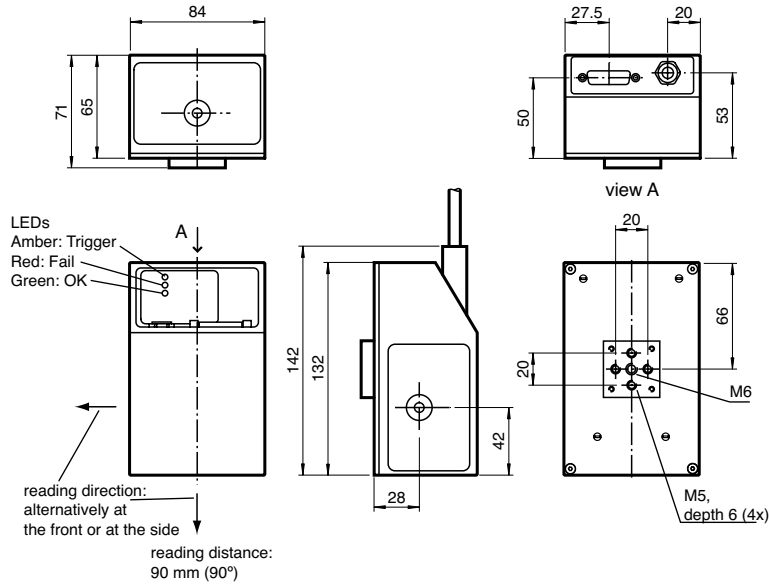

### ODT-MAC344

#### Evaluation Box

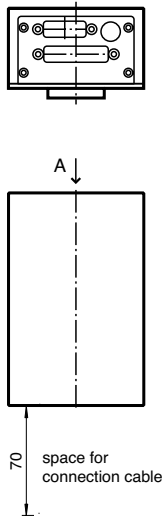

#### Read Head

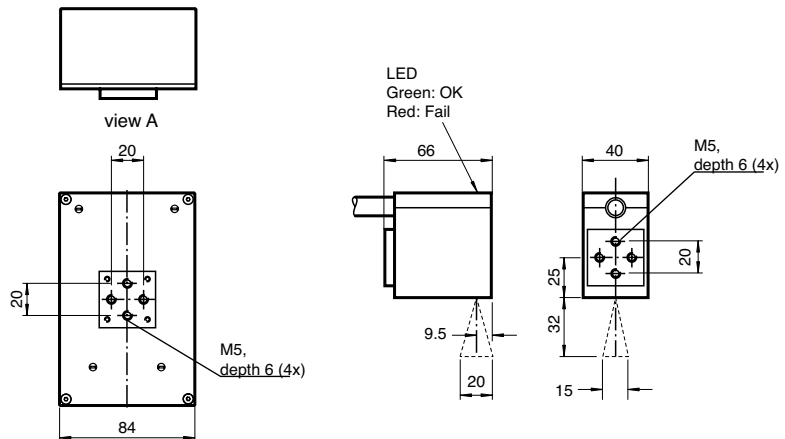

## Accessories



### Cables and Interconnects

Model	Description
ODZ-MAC-CAB-24V-R2-2M	RS-232 to 15-pin + 24 VDC connector 2.1 mm x 5.5 mm (center positive). No trigger input.
ODZ-MAC-CAB-24V-R2-2M-V1-G-2M	RS-232 to 15-pin, w/trigger connect (PNP), + 24 VDC connector 2.1 mm x 5.5 mm (center positive)
ODZ-MAC-CAB-15POL-2.5M	2.5 m 15-pin D-sub male/female extension cable
ODZ-MAC-CAB-15POL-5M-FEMALE	5 m 15-pin D-sub one end, unterminated other end
ODZ-MAC-CAB-15POL-2.5M-FEMALE	2.5 m 15-pin D-sub one end, unterminated other end
ODZ-MAC-CAB-VIDEO	MAC340/344 to VGA Video Cable
VAZ-R2-STRT	2 m 9-pin D-sub male/female extension cable



### Power Supply

Model	Description
ODZ-MAC-PWR-24V-110V	Power supply, input: 100-240 VAC 50/60 Hz, output: regulated 24 VDC @ 0.75 A, 18 W max. Compatible with ODZ-MAC-CAB-24V-R2-2M and ODZ-MAC-CAB-24V-R2-2M-V1-G-2M.

### Mounting Bracket

Model	Description
ODZ-MAC-BRACKET	Tabletop bracket, two axes

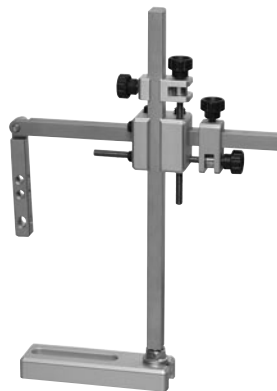

See pages 131-136 for complete Barcode accessory listing.

## Barcode Imaging Network Adapters

- EtherNet/IP
- PROFINET I/O, PROFINET CBA
- Modbus/TCP
- Ethernet TCP/IP



The RTS series facilitates the connection of our serial barcode imaging products to Ethernet networks. Depending on the unit we also offer products implementing several different industrial Ethernet protocols in addition to Ethernet TCP/IP.

### TCP/IP

The RTS series is a 1-, 4-, 8-, 16-port device server designed for network-enabling serial communications devices. When used with the supplied driver software and a host PC, the products enable placement of COM or TTY ports anywhere on an Ethernet network or across the Internet. In applications where connecting legacy serial devices to a PC without software changes is a requirement, a pair of RTS network adapters can be used to create a point-to-point serial tunnel across the network that seamlessly transfer serial data via TCP.

### ADMIN port

ADMIN port is another advantage. This unique feature is offered exclusively by Pepperl+Fuchs on the RTS 1P, 8P and 16P. A monitoring application opens this port, and information about the other open COM ports is sent at one-second intervals. This information includes whether or not the port is open, and the number of bytes transmitted and received. The system sends an alert if the port closes for any reason.

### MIRROR ports

MIRROR ports are another Pepperl+Fuchs exclusive on the RTS 1P, 8P and 16P. They enable up to three applications to receive data from the same serial port. For example, serial port 1 has default socket connections to 3001, 4001, and 5001. Only port 3001 is set to send commands to the serial device. No other applications can interfere with production-critical hardware. Data returning from the serial port is sent to all default socket connections.

### EMAIL

Another debug option is provided via email. There are over 10 different errors that can trigger an email, including device power up. This error could occur after a brownout.

### Modbus/TCP

The RTS UP-1, 4P, 8P and 16P provide Modbus/TCP over Ethernet making a seamless connection to PCs or PLCs.

### EtherNet/IP

The RTS UP-1 offers a flashable solution that configures in minutes via the web, allowing you to support major industrial Ethernet PLC networks, such as EtherNet/IP, on a single platform.

### PROFINET I/O and PROFINET CBA

The RTS UP-1 offers a flashable solution that configures in minutes via the web, allowing you to support major industrial Ethernet PLC networks, such as PROFINET, on a single platform. Whichever protocol you use, RTS UP-1 provides an RS-232/422/485 software-selectable serial connection to your PLC.



# Barcode Imaging Systems



## IDENT I System P Network Adapters

INDUSTRIAL NETWORK	Ethernet				
MODEL	RTS 1P DB9	RTS-UP-1	RTS 4P DB9	RTS 8P DB9	RTS 16P
NUMBER OF PORTS	1	1	4	8	16
LEDs	Status, Ethernet Link/Activity/Duplex		Status, Ethernet Link/Activity, Collision, 100MB Ethernet, RX/TX per port		
OPERATING VOLTAGE	5-30 VDC (power supply optional)		100-240 VAC, or 24 VDC		100-240 VAC
VOLTAGE RIPPLE	-		≤ 10% at 30 VDC		
POWER CONSUMPTION	2.1 w	2.5 w	4.8 w	6.96 w	14.3 w
REVERSE POLARITY PROTECTION	Yes				
MOUNTING	DIN rail, desktop		Desktop, rack		
NETWORK PROTOCOLS	TCP/IP	TCP/IP, EtherNet/IP, Modbus/TCP, PROFINET I/O, CBA	TCP/IP, Modbus/TCP		
BAUD RATES	10/100 Mbps				
ADDRESS	Fixed IP, DHCP				
PROTECTION (IEC)	IP20				
HUMIDITY	20% to 80% system on, 8% to 80% system off				
TEMPERATURE RANGE	<i>Working</i> -35°F to +165°F (-37°C to 74°C) <i>Storage</i> -40°F to +185°F (-40°C to +85°C)				
HOUSING MATERIAL	Stainless steel		Painted steel		
WEIGHT	8 oz		112 oz	120 oz	140 oz
APPROVALS					
SERIAL CONNECTION	DB9 male			RJ45	
POWER CONNECTION	Screw terminals		110 V USA plug, 220 V European plug		
BUS CONNECTION	RJ45		RJ45 in/ RJ45 out		RJ45

Fixed-Mount Imagers Network Adapters

## Wiring Diagrams

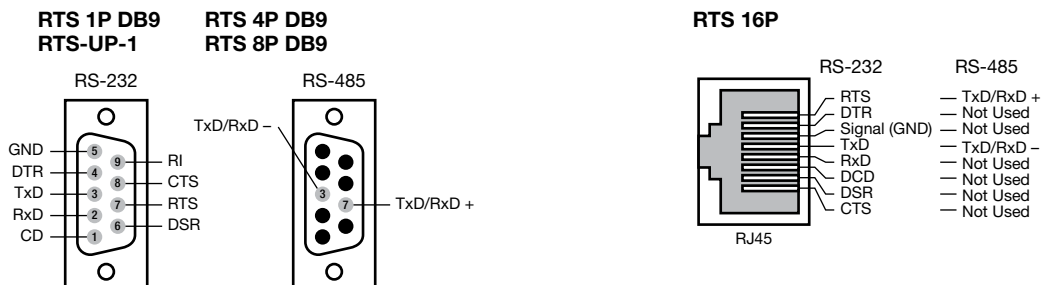

# Barcode Imaging Systems

## Dimensions (mm)

RTS 1P DB9  
RTS-UP-1

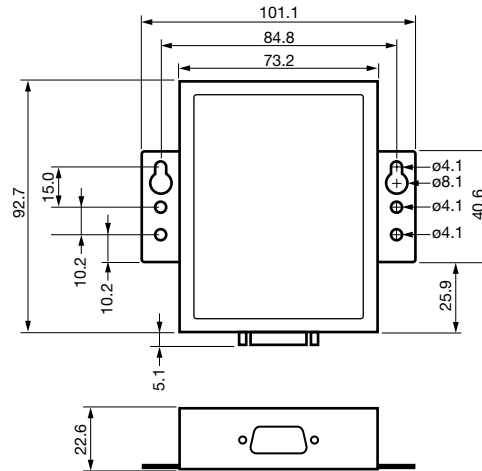

RTS 4P DB9

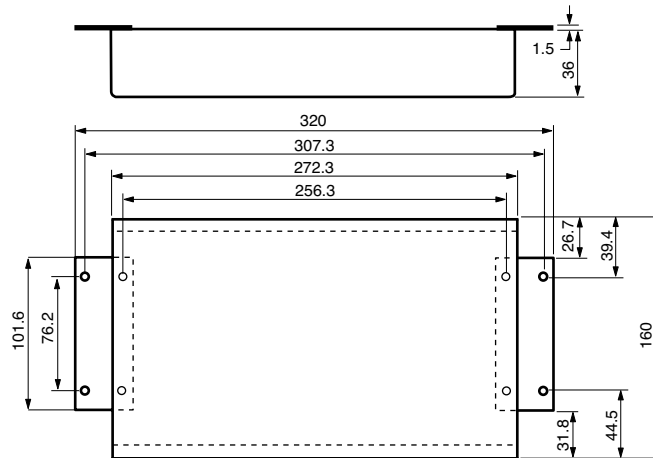

RTS 8P DB9

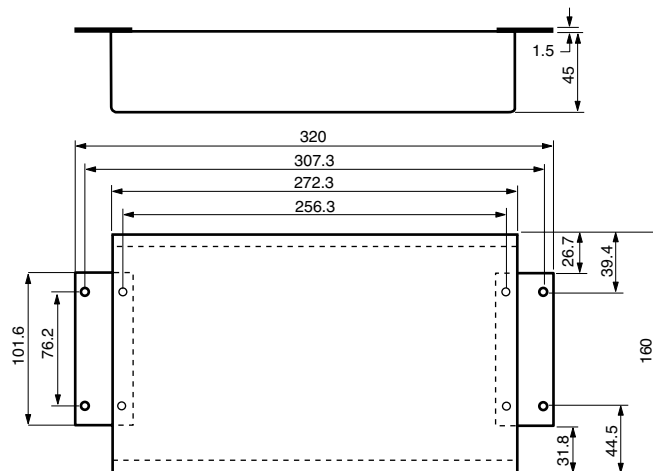

## Dimensions (mm)

RTS 16P

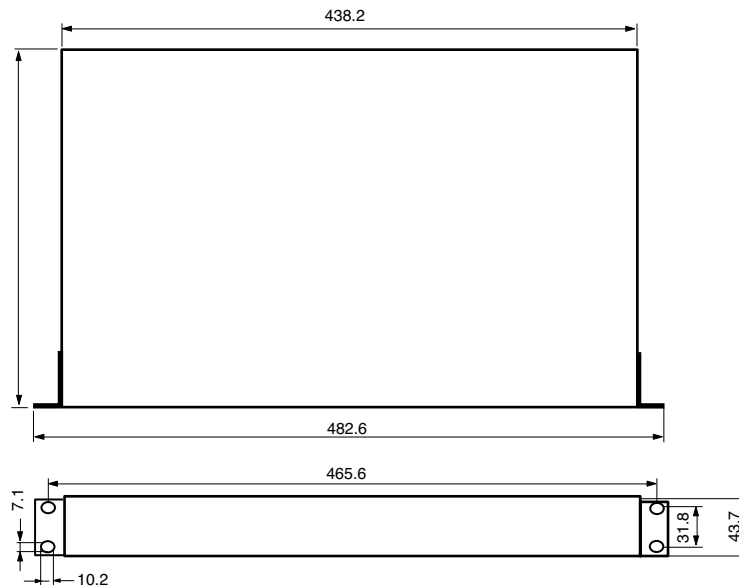

## Accessories

### Ethernet Accessories

Model	Description
V45-G-10M-V45-G	RJ45 cable, shielded 10 m



See pages 131-136 for complete Barcode accessory listing.

# Barcode Imaging Systems

---

## Notes

Fixed-Mount Imagers Network Adapters

# Barcode Imaging Accessories



**Handheld Accessories ..... 132-133**  
**Fixed Mount Accessories..... 134-135**

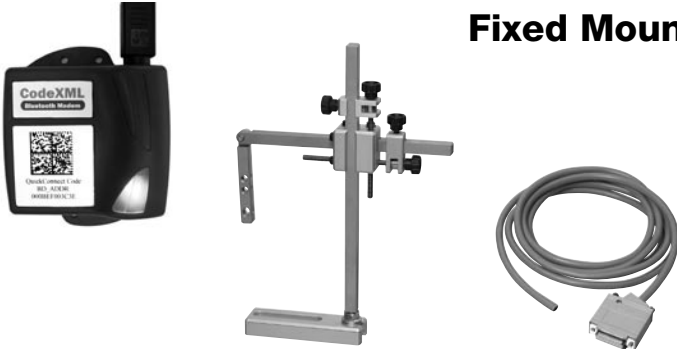

# Barcode Imaging Accessories

## Handheld Accessories

### ODZ-MAH200-GRIP Pistol Grip

For those who prefer gun-style handhelds, the ODZ-MAH200-GRIP is a clip-on pistol-grip handle. The handle is lightweight, simple to attach, durable, and performs extremely well in multiple drop tests.



ODZ-MAH200-GRIP

### ODZ-MAH-GRIP1, ODZ-MAH-GRIP2, ODZ-MAH-GRIP3 Rugged Pistol Grips

Designed for rugged operation, these grips withstand harsh conditions in high-use environments. GRIP1 is used with the USB, RS-232, or PS/2 interconnect cables (see below). GRIP2 and GRIP3 offer a new level of cordless mobility in demanding applications. GRIP 2 comes with a standard-capacity battery, while the GRIP 3 has a high-capacity battery system.

#### Features:

- Extended trigger life: three million activations
- Screw attachment option to secure reader to handle
- Optional cable attachment clip to secure cable to handle
- Elastomer overmold improves drop-shock survivability
- Accommodates optional lanyard attachment to connect to belt or hook



ODZ-MAH-GRIP1



ODZ-MAH-GRIP2  
ODZ-MAH-GRIP3

Model Number	Description
ODZ-MAH-GRIP	Clip-on pistol grip (requires battery or battery blank and cable)
ODZ-MAH-GRIP1	Ruggedized cable handle (requires cable)
ODZ-MAH-GRIP2	Ruggedized battery handle, 1950 mAh*
ODZ-MAH-GRIP3	Ruggedized battery handle, 3900 mAh*

\*We continuously improve our products, consult factory for current mAh ratings.

### Interconnect Cables

The MAH200 and MAH300 are connected with an optional USB, RS-232, PS/2 or stand alone-power cable. The USB cable is 6 feet (1.83 meters) long. The RS-232 cable is a coiled 8 foot (2.43 meters) cable and is available with an optional power supply. The PS/2 cable is a 6 foot (1.83 meters) coiled cable. The stand-alone power cable is a 6 foot (1.83 meters) straight cable.



Model Number	Description
ODZ-MAH-CAB-B14	USB cable, 6 ft.
ODZ-MAH-CAB-B14-3.7M	USB cable, 12 ft.
ODZ-MAH-CAB-R2	RS-232 cable, 8 ft. (requires ODZ-MAH-5V-110V power supply)
ODZ-MAH-CAB-R6	PS/2 keyboard wedge cable, 8 ft.
ODZ-MAH-PWR-CABL	Charging cable (requires ODZ-MAH-5V-110V power supply)

### Batteries/Power Supplies

The MAH200 and MAH300 can use a high-capacity lithium ion battery, allowing you to operate the unit for more than a complete shift at the highest use rate.

A multi-function, 2-bay battery charger, charges MAH200 units or individual batteries. It cannot charge MAH300 units (but will charge its batteries if removed from the unit). It is designed for multiple units to fit together and has a charge indicator LED for each slot (one unit and one spare battery). Approximate charge time: 4 hours.

The ODZ-MAH-5V-110V is an external power supply for the MAH200 and MAH300.



Model Number	Description
ODZ-MAH-BAT	High-capacity battery, 1950 mAh*
ODZ-MAH-BLANK	Battery blank (order interconnect cable separately)
ODZ-MAH200-CHARGER	Battery charger
ODZ-MAH-5V-110V	5 VDC power supply

\*We continuously improve our products, consult factory for current mAh ratings.

### Bluetooth Modem

The Bluetooth modem features a Bluetooth 2.4 GHz wireless transceiver enabling reliable, two-way communication and optional security between the MAH200, MAH300 and a host computer or system that supports keyboard, USB or serial input/output.

Simply plug the modem into your computer using the appropriate cable and the unit is ready. There is no need to load any drivers (including Bluetooth Manager drivers). The Bluetooth modem is a simple hardware solution for customers who wish to enjoy the benefits of cordless data collection without modifying existing applications or installing software. The radio firmware is easily upgradable.



#### Features:

- Bluetooth to keyboard, USB or serial input/output
- Seamless integration with MAH200 & MAH300
- Simple installation: simply plug-in the modem and start transmitting wireless data
- Extended range: reader to modem separation up to 100 m (300 ft)
- Mountable to working surfaces (four drilled holes in casing)

#### Specifications for ODZ-MAH-B15

ELECTRICAL DATA	
Bluetooth Class	Class I Bluetooth radio
Frequency/Emission	2.4 GHz ISM band, frequency hopping spread spectrum (FHSS GFSK)
RF Data Rate	1 Mbps
Data Throughput	115 kbps maximum
Power Source	5 VDC (from USB, PS/2 or external supply)
Bluetooth Device	V1.2; SPP (Serial Port Profile) - Slave
ENVIRONMENTAL DATA	
Operating Temperature	+32°F to +158°F (0°C to +70°C)
Range/Distance	100 m (300 ft) - line of sight
Antenna	Internal

Model Number	Description
ODZ-MAH-B15	Wireless Bluetooth to USB, PS/2, or RS-232 (interconnect cable not included, see above)

### Software

The CodeXML router allows you to easily connect a MAH200 or MAH300 to any PDA running a Windows Mobile or CE application that accepts keystroke data (e.g., Word, Excel, Notepad).



Model Number	Description
ODZ-MAH200-CODEROUTER	ODZ-MAH200-CODEROUTER software on CD

### Mounting Bracket

Reader stands enable a fixed placement of either the MAH200 or MAH300 reader. It features a 6 inch square base and is approximately 12.5 inches high.



Model Number	Description
ODZ-MAH200-BRACKET	Bracket/stand for ODT-HH-MAH200
ODZ-MAH300 BRACKET	Bracket/stand for ODT-HH-MAH300

# Barcode Imaging Accessories

## Fixed Mount Accessories

### Cables and Interconnects

ODZ-MAC-CAB-24V-R2-2M-V1-G-2M interconnect cable provides connection between P+F imager (MAC333, MAC340, MAC344) and computer via RS-232 interface. In addition, it provides connection of optional 24 VDC regulated power supply sourcing at least 600 mA and a PNP trigger input.

The ODZ-MAC-CAB-15POL-...M-FEMALE provides connection between MAC333, MAC340 and MAC344 to upstream equipment. Cable has compatible 15-pin D-sub connector on one side to unterminated wire at other end of the cable and comes in 2.5 and 5 meter lengths. See color code table at right.

The ODZ-MAC-CAB-15POL-2.5M is a male to female 15-position extension cable 2.5 m long.

The ODZ-MAC-CAB-VIDEO cable is useful in connecting a MAC340 or MAC344 to a standard analog VGA (15 pin) monitor. It allows the user to see the camera output, adjust position of the image with respect to the trigger input, and adjust the focus, contrast and exposure of the image.

The VAZ-R2-STRT is a M/F DB9 extension cable. It does not provide any crossover or null modem features.

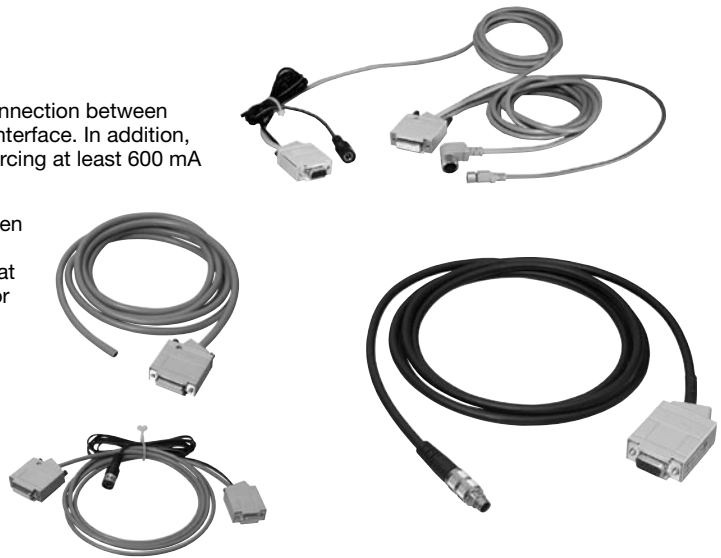

Model	Description
<b>ODZ-MAC-CAB-24V-R2-2M</b>	RS-232 to 15-pin + 24 VDC connector 2.1 mm x 5.5 mm (center positive). No trigger input.
<b>ODZ-MAC-CAB-24V-R2-2M-V1-G-2M</b>	RS-232 to 15-pin, w/trigger connect (PNP), + 24 VDC connector 2.1 mm x 5.5 mm (center positive)
<b>ODZ-MAC-CAB-15POL-2.5M</b>	2.5 m 15-pin D-sub male/female extension cable
<b>ODZ-MAC-CAB-15POL-2.5M-FEMALE</b>	2.5 m 15-pin D-sub one end, unterminated other end
<b>ODZ-MAC-CAB-15POL-5M-FEMALE</b>	5 m 15-pin D-sub one end, unterminated other end
<b>ODZ-MAC-CAB-VIDEO</b>	MAC340/344 to VGA video cable
<b>VAZ-R2-STRT</b>	2 m 9-pin D-sub male/female extension cable

### ODZ-MAC-CAB-15POL-...M-FEMALE Color Code

Sub-D Pinout	Signal	Color
1	GND	Brown
2	GND	Red
3	Trigger-GND	Pink
4	24+ V	Yellow
5	24+ V	Green
6	24+ V	Blue
7	RTS (RS-232)	Violet
8	Reserved	Grey
9	Output - Good	White
10	Output - Fail	Black
11	Trigger Input	White/Green
12	CTS (RS-232)	White/Yellow
13	RXD (RS-232)	Brown/Green
14	TXD (RS-232)	Red/Blue
15	Reserved	Grey/Pink

### ODZ-MAC-CAB-24V-R2-2M-V1-G-2M

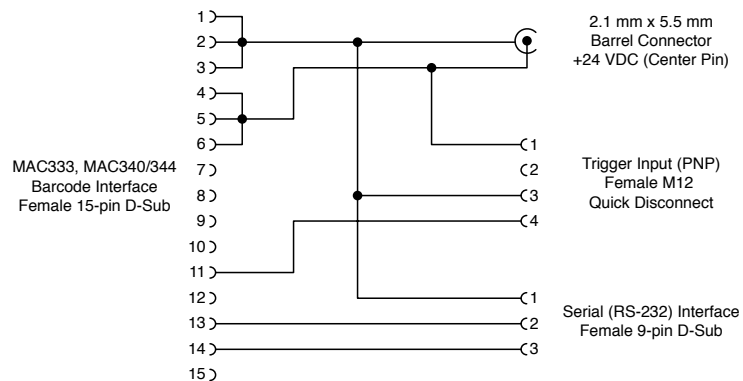



### Power Supply

For the MAC333, MAC340 and MAC344, an external power supply is available for RS-232 cable. The power supply is useful for testing, troubleshooting and initial startup, and is compatible with the ODZ-MAC-CAB-24V-R2-2M and the ODZ-MAC-CAB-24V-R2-2M-V1-G-2M cables.



Model	Description
<b>ODZ-MAC-PWR-24V-110V</b>	Power supply, input: 100-240 VAC 50/60 Hz, output: regulated 24 VDC @ 0.75 A, 18 W max.

### Mounting Bracket

Our universal mount provides a secure attachment for your MAC333, MAC340 or MAC344 (read head). For precise adjustment it has coarse and fine adjustment across its range of approximately 7" (~175 mm) and two axes of adjustment on the bracket at 90° to each other.

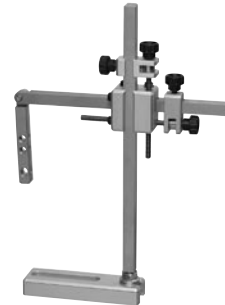

Model	Description
<b>ODZ-MAC-BRACKET</b>	Tabletop bracket, two axes

# Barcode Imaging Accessories

---

## Notes

# Appendix

<b>Conversion Tables .....</b>	<b>138-139</b>
<b>Chemical Resistivity Charts.....</b>	<b>140</b>
<b>IP Ratings .....</b>	<b>141</b>
<b>Warranty Terms and Conditions.....</b>	<b>142</b>
<b>Model Number Index.....</b>	<b>143-144</b>

# Appendix

## Conversion Tables

### Temperature Conversions

Celsius	Fahrenheit	Celsius	Fahrenheit	Celsius	Fahrenheit	Celsius	Fahrenheit
-273	-459.4	-57	-70	0.6	33	22.8	73
-268	-450	-51	-60	1.1	34	23.3	74
-262	-440	-46	-50	1.7	35	23.9	75
-257	-430	-40	-40	2.2	36	24.4	76
-251	-420	-34	-30	2.8	37	25.0	77
-246	-410	-29	-20	3.3	38	25.6	78
-240	-400	-23	-10	3.9	39	26.1	79
-234	-390	-17.8	0	4.4	40	26.7	80
-229	-380	-17.2	1	5.0	41	27.2	81
-223	-370	-16.7	2	5.6	42	27.8	82
-218	-360	-16.1	3	6.1	43	28.3	83
-212	-350	-15.6	4	6.7	44	28.9	84
-207	-340	-15.0	5	7.2	45	29.4	85
-201	-330	-14.4	6	7.8	46	30.0	86
-196	-320	-13.9	7	8.3	47	30.6	87
-190	-310	-13.3	8	8.9	48	31.1	88
-184	-300	-12.8	9	9.4	49	31.7	89
-179	-290	-12.2	10	10.0	50	32.2	90
-173	-280	-11.7	11	10.6	51	32.8	91
-169	-273	-11.1	12	11.1	52	33.3	92
-168	-270	-10.6	13	11.7	53	33.9	93
-162	-260	-10.0	14	12.2	54	34.4	94
-157	-250	- 9.4	15	12.8	55	35.0	95
-151	-240	- 8.9	16	13.3	56	35.6	96
-146	-230	- 8.3	17	13.9	57	36.1	97
-140	-220	- 7.8	18	14.4	58	36.7	98
-134	-210	- 7.2	19	15.0	59	37.2	99
-129	-200	- 6.7	20	15.6	60	37.8	100
-123	-190	- 6.1	21	16.1	61	43	110
-118	-180	- 5.6	22	16.7	62	49	120
-112	-170	- 5.0	23	17.2	63	54	130
-107	-160	- 4.4	24	17.8	64	60	140
-101	-150	- 3.9	25	18.3	65	66	150
- 96	-140	- 3.3	26	18.9	66	71	160
- 90	-130	- 2.8	27	19.4	67	77	170
- 84	-120	- 2.2	28	20.0	68	82	180
- 79	-110	- 1.7	29	20.6	69	88	190
- 73	-100	- 1.1	30	21.1	70	93	200
- 68	- 90	- 0.6	31	21.7	71	99	210
- 62	- 80	0.0	32	22.2	72	100	212

For temperatures not given in table, or to convert to other temperature scales, use the following:

$$^{\circ}\text{C} = (^{\circ}\text{F} - 32) \times 5/9$$

$$^{\circ}\text{F} = (^{\circ}\text{C} \times 9/5) + 32$$

$$^{\circ}\text{K} = ^{\circ}\text{C} + 273$$

## Conversion Tables

Millimeters to Inches	
mm	in.
25	.98425
26	1.02362
27	1.06299
28	1.10236
29	1.14173
30	1.18110
31	1.22047
32	1.25984
33	1.29921
34	1.33858
35	1.37795
36	1.41732
37	1.45669
38	1.49606
39	1.53543
40	1.57480
41	1.61417
42	1.65354
43	1.69291
44	1.73228
45	1.77165
46	1.81102
47	1.85039
48	1.88976
49	1.92913
50	1.96850
51	2.00787
52	2.04724
53	2.08661
54	2.12598
55	2.16535
56	2.20472
57	2.24409
58	2.28346
59	2.32283
60	2.36220
61	2.40157
62	2.44094
63	2.48031
64	2.51968
65	2.55905
66	2.59842
67	2.63779
68	2.67716
69	2.71653
70	2.75590
71	2.79527
72	2.83464
73	2.87401
74	2.91338
75	2.95275
76	2.99212
77	3.03149
78	3.07086
79	3.11023
80	3.14960
81	3.18897
82	3.22834
83	3.26771
84	3.30708
85	3.34645
86	3.38582
87	3.42519
88	3.46456
89	3.50393
90	3.54330
91	3.58267
92	3.62204
93	3.66141
94	3.70078
95	3.74015
96	3.77952
97	3.81889
98	3.85826
99	3.89763
100	3.93700

Inches to Millimeters	
in.	mm
1	25.4
2	50.8
3	76.2
4	101.6
5	127.0
6	152.4
7	177.8
8	203.2
9	228.6
10	254.0
11	279.4
12	304.8
13	330.2
14	355.6
15	381.0
16	406.4
17	431.8
18	457.2
19	482.6
20	508.0
21	533.4
22	558.8
23	584.2
24	609.6
25	635.0
26	660.4
27	685.8
28	711.2
29	737.6
30	762.0
31	787.4
32	812.8
33	838.2
34	863.6
35	889.0
36	914.4
37	939.8
38	965.2
39	990.6
40	1016.0
41	1041.4
42	1066.8
43	1092.2
44	1117.6
45	1143.0
46	1168.4
47	1193.8
48	1219.2
49	1244.6
50	1270.0
51	1295.4
52	1320.8
53	1346.2
54	1371.6
55	1397.0

Feet	Inches	mm
5	60	1524.0
6	72	1828.8
7	84	2133.6
8	96	2438.4
9	108	2743.2
10	120	3048.0
11	132	3352.8
12	144	3657.6
13	156	3962.4
14	168	4267.2
15	180	4572.0
16	192	4876.8
17	204	5181.6
18	216	5486.4
19	228	5791.2

Fractional Inches	Decimal Inches	Millimeters
1/64	.015625	0.397
1/32	.03125	0.794
	<b>.03937</b>	<b>1 mm</b>
3/64	.046875	1.191
1/16	.0625	1.588
5/64	.078125	1.984
	<b>.07874</b>	<b>2 mm</b>
3/32	.09375	2.381
7/64	.109375	2.778
	<b>.11811</b>	<b>3 mm</b>
1/8	.125	3.175
9/64	.140625	3.572
5/32	.15625	3.969
	<b>.15748</b>	<b>4 mm</b>
11/64	.171875	4.366
3/16	.1875	4.763
	<b>.19685</b>	<b>5 mm</b>
13/64	.203125	5.159
7/32	.21875	5.556
15/64	.234375	5.953
	<b>.23622</b>	<b>6 mm</b>
1/4	.250	6.350
17/64	.265625	6.747
	<b>.27559</b>	<b>7 mm</b>
9/32	.28125	7.144
19/64	.296875	7.540
5/16	.3125	7.938
	<b>.31496</b>	<b>8 mm</b>
21/64	.328125	8.334
11/32	.34375	8.731
	<b>.35433</b>	<b>9 mm</b>
23/64	.359375	9.128
3/8	.375	9.525
25/64	.390625	9.922
	<b>.3937</b>	<b>10 mm</b>
13/32	.40625	10.319
27/64	.421875	10.716
	<b>.43307</b>	<b>11 mm</b>
7/16	.4375	11.113
29/64	.453125	11.509
15/32	.46875	11.906
	<b>.47244</b>	<b>12 mm</b>
31/64	.484375	12.303
1/2	.500	12.700
	<b>.51181</b>	<b>13 mm</b>
33/64	.515625	13.097
17/32	.53125	13.494

Fractional Inches	Decimal Inches	Millimeters
35/64	.546875	13.891
	<b>.55118</b>	<b>14 mm</b>
9/16	.5625	14.288
37/64	.578125	14.684
	<b>.59055</b>	<b>15 mm</b>
19/32	.59375	15.081
39/64	.609375	15.478
5/8	.625	15.875
	<b>.62992</b>	<b>16 mm</b>
41/64	.640625	16.272
21/32	.65625	16.669
	<b>.66929</b>	<b>17 mm</b>
43/64	.671875	17.006
11/16	.6875	17.463
45/64	.703125	17.859
	<b>.70886</b>	<b>18 mm</b>
23/32	.71875	18.256
47/64	.734375	18.653
	<b>.74803</b>	<b>19 mm</b>
3/4	.750	19.050
49/64	.765625	19.447
25/32	.781250	19.844
	<b>.7874</b>	<b>20 mm</b>
51/64	.796875	20.241
13/16	.8125	20.638
	<b>.82677</b>	<b>21 mm</b>
53/64	.828125	21.034
27/32	.84375	21.431
55/64	.859375	21.828
	<b>.86614</b>	<b>22 mm</b>
7/8	.8750	22.225
57/64	.890625	22.622
	<b>.90551</b>	<b>23 mm</b>
29/32	.90625	23.019
59/64	.921875	23.416
15/16	.9375	23.813
	<b>.94488</b>	<b>24 mm</b>
61/64	.953125	24.209
31/32	.96875	24.606
	<b>.98425</b>	<b>25 mm</b>
63/64	.984375	25.003
1"	1.000	25.400

# Appendix

## Chemical Resistivity Charts

A= excellent

B= good

C= moderate

D= nonresistive

### METALS

This chemical resistance chart rates the effect of chemicals on metals used in the construction of Pepperl+Fuchs' level control product line. Concentration of chemicals listed are 100%, unless otherwise specified.

	302/304 SS	316 SS	Hastelloy	Titanium	Aluminum	Tantalum
Citric acid	A	A	A	A	C	-
Copper chloride	C	D	A	A	D	-
Cresols 2	A	A	-	-	B	A
Detergents	A	A	-	-	A	A
Diesel fuel	A	A	-	-	A	-
Dyes	A	A	-	-	B	-
Ethyl acetate	A	A	B	-	B	-
Ferric chloride	D	D	B	A	D	-
Ferric sulfate	A	C	A	A	D	A
Formic acid	C	B	A	C	D	-
Fuel oils	A	A	A	A	A	A
Gasoline	A	A	A	D	A	-
Grease 4	A	A	-	-	A	-
Hydraulic oil	A	A	-	-	A	-
Hydrochloric acid (20%)	-	D	B	C	D	-
Hydrofluoric acid(20%)	-	D	B	D	D	-
Hydrogen peroxide (10%)	-	C	A	C	A	-
Hydrogen sulfide (aqueous)	-	A	A	A	C	-
Isopropyl acetate	-	B	-	-	C	-
Kerosene 2	A	A	A	A	A	A
Lubricants	-	A	A	A	A	-
Magnesium sulfate	B	-	B	A	B	-
Methyl acetate	A	A	A	-	A	-
Methyl alcohol	A	A	A	B	A	-
Methylene chloride	B	B	B	B	A	-
Nitric acid (20%)	A	A	A	A	D	-
Oil (soybean)	A	A	A	A	B	A
Phosphoric acid (40%)	A	B	A	B	C	-
Potassium sulfide	B	A	-	A	-	-
Propane (liquified)	A	A	A	-	A	-
Sodium carbonate	B	A	A	A	D	-
Sodium hydroxide (20%)	B	A	B	A	D	-
Sodium sulfate	B	B	B	A	A	-
Sulfuric acid (10-75%)	D	D	B	D	D	-
Xylene	A	A	A	A	A	A

### PLASTICS

This chemical resistance chart rates the effect of chemicals on plastics used in the construction of Pepperl+Fuchs' level control product line. Concentration of chemicals listed are 100%, unless otherwise specified.

	PVC	PUR	Hypalon (CSM)	Teflon	Polyethylene	Polypropylene	Viton
Citric acid	B	A	A	A	B	B	A
Copper chloride	A	A	A	A	B	A	A
Cresols 2	D	D	D	A	D	C	A
Detergents	A	D	-	A	B	A	A
Diesel fuel	-	D	-	A	-	D	A
Dyes	B	-	-	-	-	-	A
Ethyl acetate	D	D	D	A	C	C	D
Ferric chloride	A	B	B	A	B	A	A
Ferric sulfate	A	-	A	A	-	A	A
Formic acid	D	-	-	A	B	A	B
Fuel oils	A	D	D	A	D	B	A
Gasoline	C	B	B	A	D	C	A
Grease 4	A	A	-	A	-	-	A
Hydraulic oil	A	-	B	A	-	D	A
Hydrochloric acid (20%)	A	-	A	A	A	A	A
Hydrofluoric acid(20%)	D	B	A	A	C	A	A
Hydrogen peroxide (10%)	A	-	-	A	A	-	-
Hydrogen sulfide (aqueous)	A	-	B	A	B	A	B
Isopropyl acetate	B	D	-	-	-	-	D
Kerosene 2	A	B	-	A	D	D	A
Lubricants	A	C	D	A	-	A	A
Magnesium sulfate	A	-	A	A	B	A	A
Methyl acetate	-	-	D	A	-	-	D
Methyl alcohol	A	D	A	A	A	A	D
Methylene chloride	D	D	-	A	C	B	B
Nitric acid (20%)	A	D	D	A	C	A	A
Oil (soybean)	B	A	B	A	A	A	A
Phosphoric acid (40%)	A	A	-	A	A	A	A
Potassium sulfide	A	C	B	A	A	A	A
Propane (liquified)	A	D	B	-	C	B	A
Sodium carbonate	-	A	A	A	B	A	A
Sodium hydroxide (20%)	A	C	A	A	A	A	B
Sodium sulfate	A	A	A	A	A	A	A
Sulfuric acid (10-75%)	A	-	C	A	A	A	A
Xylene	D	D	D	A	C	C	A

These charts are a general guide and do not guarantee chemical compatibility. Pepperl+Fuchs, Inc. assumes no responsibility for the use of this information.

### Definition:

The first numeral defines the amount of protection against penetration of solid objects into the housing.

The second numeral defines the amount of protection against liquids penetrating the housing.

Additional information on ratings can be found in the following chart or the 1976 IEC Publication, Classification of Degrees of Protection Provided by Enclosures.

### Example: What is IP67?

Complete protection of live parts. Protection against the penetration of dust. Additionally, it will be protected while immersed in water.

### Testing Criteria:

1. Test Class: IP67 test  
 Conditions: 1m head of water over the test piece for a duration of 30 minutes.  
 Room temperature  $\pm 5^{\circ}\text{C}$   
 Test: Insulation and operation
2. Test Class: IP68 test (Encapsulated products)  
 Conditions: 1m head of water over the test piece for 24 hours of operation under water, with cyclical activation and deactivation under nominal loading Cycle time 2 hours  
 Room temperature  $\pm 5^{\circ}\text{C}$   
 Test: Insulation and operation
3. Test Class: IP69k test  
 Conditions: Protection against ingress of water from jets at a pressure of 1450 psi and at temperatures of up to  $80^{\circ}\text{C}$ . This is the level of pressure and temperature required for thorough cleaning of meat, fish, poultry and dairy processing lines.

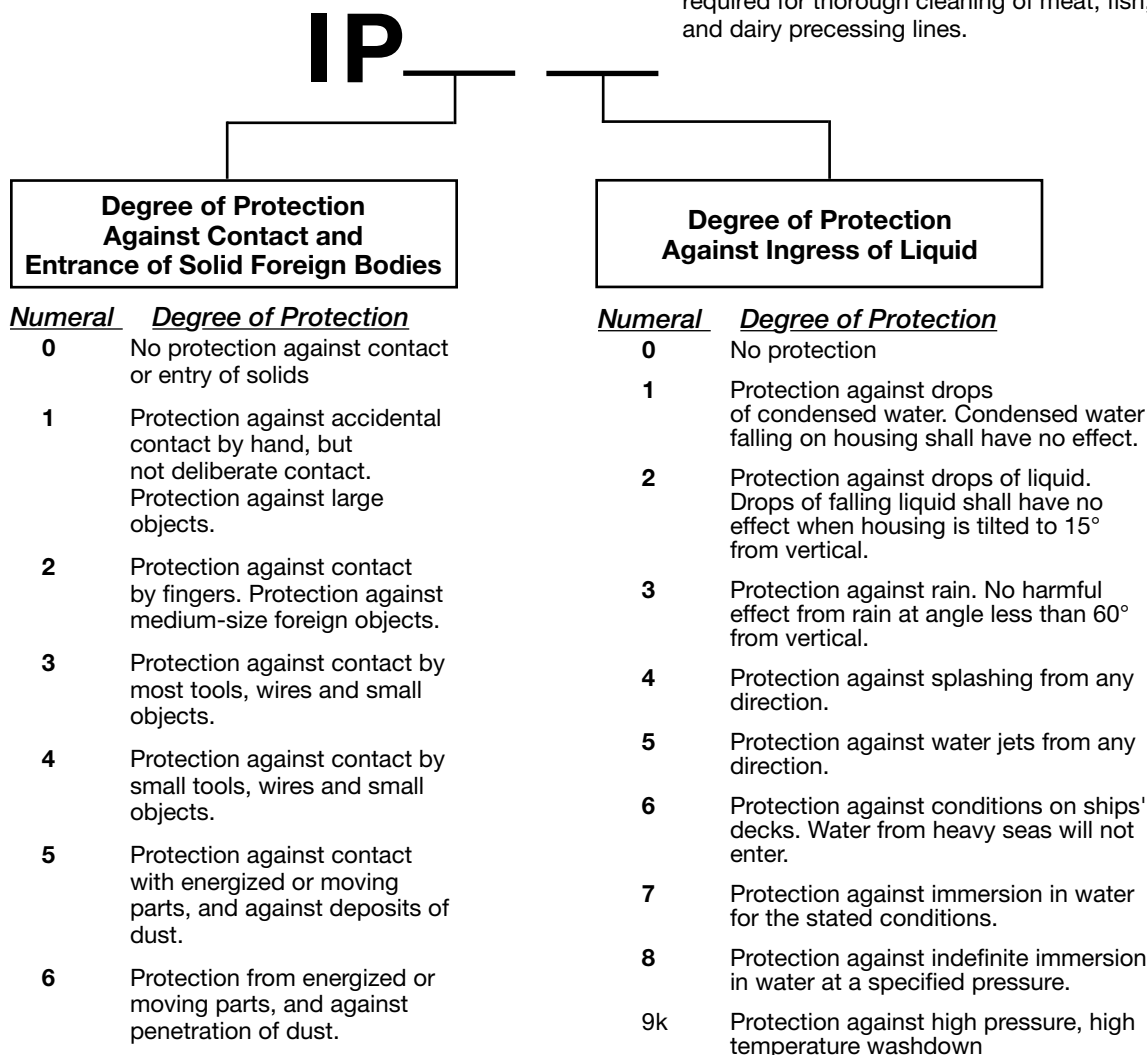

## Pepperl+Fuchs Warranty Terms and Conditions

### STANDARD 18-MONTH WARRANTY

Subject to the conditions and requirements set forth herein, P+F warrants the products covered by the respective warranties to be free from defects in material and workmanship under normal and proper usage for the respective time periods listed above from the date of shipment from P+F (or from an authorized representative or distributor of P+F). In addition, certain specific terms apply to various warranties.

THESE EXPRESS WARRANTIES ARE IN LIEU OF AND EXCLUDE ALL OTHER REPRESENTATIONS MADE — BOTH EXPRESS AND IMPLIED, INCLUDING ANY IMPLIED WARRANTIES OF MERCHANTABILITY, FITNESS FOR A PARTICULAR PURPOSE, OR THAT THE PRODUCTS ARE FREE OF ANY CLAIM OF ANY THIRD PERSON BY WAY OF INFRINGEMENT OR THE LIKE, and are also in lieu of and exclude any promise, description, affirmation of fact, sample model or representation, oral or written, which may be part of an order or made by a representative of P+F or otherwise. This WARRANTY shall not apply to any product which has been subject to misuse, negligence, or accident, or to any product which has been modified or repaired, improperly installed, altered or disassembled (except according to P+F's written instructions) or any product if the machinery, equipment, or production line to which the product is originally connected or on which the product is originally installed is abandoned, changed, substituted, moved or replaced or if the product is removed from such machinery, equipment or production line or other original application.

This WARRANTY is subject to the following conditions:

- 1) This WARRANTY is limited to the electronic and mechanical performance only, as expressly detailed in the product specifications and NOT to cosmetic performance.
- 2) This WARRANTY shall not apply to any cables attached to, or integrated with the product. However, it shall apply to cables sold separately by P+F.
- 3) This WARRANTY shall not apply to any products which are stored, or utilized, in harsh environmental or electrical conditions outside P+F's written specifications.
- 4) The WARRANTY is applicable only to products shipped from P+F subsequent to January 1, 1992.
- 5) All claims under this WARRANTY must be made in writing within thirty (30) days of the date on which the defect is (or, with reasonable diligence, should have been) discovered.

### PRODUCTS TO WHICH STANDARD 18-MONTH WARRANTY APPLIES

Ultrasonic sensors, level controls, photoelectric sensors, read-write ID systems, encoders, counters, signal conditioners and all products with electromechanical relays or circuit breakers.

### CONSIDER SAFETY AND PROTECTION PRECAUTIONS

P+F takes great care to design and build reliable and dependable products; however, some products can fail eventually. You must take precautions to design your equipment to prevent property damage and personal injury in the unlikely event of failure. As a matter of policy, P+F does NOT recommend the installation of electronic controls as the sole device FOR THE PROTECTION OF PERSONNEL in connection with power driven presses, brakes, shears and similar equipment and, therefore, the customer should build in redundancy or dual control using approved safety devices for these applications.

### DELIVERY

Pepperl+Fuchs® Inc. will deliver its products F.O.B. from its warehouse, place of manufacture or other place from which the products are actually shipped within the U.S.A.

Freight charges will be prepaid and added to invoice.



## A

AB-18.....	92
AB-30.....	92

## B

BF18.....	92
BF30.....	92
BF5-30.....	93

## D

DNV15-G-YE1M-PVC-V95-G.....	31, 69, 88
DNV95-G-0M-T-0M-V95-G-L.....	31, 69, 88
DNV95-G-BK15M-PVC-V95-G.....	31, 69, 88
DNV95-G-BK25M-PVC-V95-G.....	31, 69, 88
DNV95-G-BK50M-PVC-V95-G.....	31, 69, 88
DNV95-G-BK5M-PVC-V95-G.....	31, 69, 88
DNV95-G-TERM.....	31, 69, 88

## I

IC-KP-B12-V45.....	29
IC-KP-B6-SUBD.....	29
IC-KP-B6-V15B.....	29
IC-KP-B7-V95.....	29
IC-KP-R2-V1.....	29
ICC-12A.....	50
ICC-12A-T1.....	50
ICC-16GKA.....	50
ICC-30GKA-T1.....	51
ICC-30GKA-T3.....	51
ICC-50A.....	51
ICC-8A.....	50
ICS-30GK.....	94
ICZ-2T/TR-0.2M-PUR ABG-V15B-G.....	90
ICZ-3T-0.2M-PUR ABG-V15B-G.....	90
ICZ-3T-V15B.....	90
ICZ-TR-V15B.....	90
ICZ-V45.....	88
IDC-10-1K.....	52
IDC-12-1K.....	52
IDC-15-1K.....	52
IDC-16GK-1K.....	53
IDC-24-1K.....	53
IDC-24-1K-Y94646.....	53
IDC-30F-1K.....	54
IDC-30GK-1K.....	53
IDC-50-1K.....	54
IDC-50F-1K.....	54
IDC-58-1K.....	54
IDC-8-1K.....	52
IPC02-12.....	40
IPC02-16.....	40, 71

IPC02-20CD.....	40, 71
IPC02-20W.....	40, 71
IPC02-30W.....	41, 72
IPC02-50W.....	41, 72
IPC02-68-T7.....	41, 72
IPC02-C1.....	41, 72
IPC03-100.....	44, 75
IPC03-12.4.....	45
IPC03-16GK.....	45
IPC03-20CT.....	46, 76
IPC03-20K1.....	43, 74
IPC03-20W.....	43, 74
IPC03-24.....	45
IPC03-30GK.....	45
IPC03-30W.....	43, 74
IPC03-50P.....	44, 75
IPC03-54-T8.....	46, 76
IPC03-58.....	46, 76
IPC03-C1.....	44, 75
IPC11-12.....	42
IPC11-30.....	42, 73
IPC11-50.....	42, 73
IPC12-58-64K.....	46, 76
IPG-G4-B7-V15.....	67
IPH-18GM-V1.....	39
IPH-30GM-V1.....	39
IPH-F15-V1.....	39
IPH-F61-V1.....	39
IPH-FP-V1.....	39
IPH-L2-V1.....	39
IPT-HH20.....	79
IPT1-FP.....	61
IPZ-MH50.....	94
IQC21-30P.....	34
IQC21-50P.....	34
IQC21-58.....	34
IQC22-C1.....	35
IQC22-C4.....	35
IQC22-C5.....	35
IQH-18GM-V1.....	33
IQH-F100-V1.....	33
IQH-FP-V1.....	33
IQT-HH20.....	79
ISH-18GM-V1.....	49
ISH-F61-V1.....	49
ISH-FP-V1.....	49
IST-HH20.....	79
IVZ-16GK-EW.....	94
IVZ-30G-EW.....	94

## M

MVC-60B-64K.....	57
MVC-SH1.....	94
MVH2000-F15-V1.....	57
MVH500-F15-V1.....	57

# Model Number Index

## O

ODT-HH-MAH200.....	111
ODT-HH-MAH200-B15.....	111
ODT-HH-MAH300.....	111
ODT-HH-MAH300-B15.....	111
ODT-MAC333.....	117
ODT-MAC340.....	122
ODT-MAC340-HD.....	122
ODT-MAC340-INC.....	122
ODT-MAC340-OCR.....	122
ODT-MAC344-OCR.....	123
ODT-MAC344-WHITE.....	123
ODZ-MAC-BRACKET.....	135
ODZ-MAC-CAB-15POL-2.5M.....	134
ODZ-MAC-CAB-15POL-2.5M-FEMALE.....	134
ODZ-MAC-CAB-15POL-5M-FEMALE.....	134
ODZ-MAC-CAB-24V-R2-2M.....	134
ODZ-MAC-CAB-24V-R2-2M-V1-G-2M.....	134
ODZ-MAC-CAB-VIDEO.....	134
ODZ-MAC-PWR-24V-110V.....	135
ODZ-MAH-5V-110V.....	95, 132
ODZ-MAH-B15.....	96, 133
ODZ-MAH-BAT.....	95, 132
ODZ-MAH-BLANK.....	95, 132
ODZ-MAH-CAB-B14.....	95, 132
ODZ-MAH-CAB-B14-3.7M.....	95, 132
ODZ-MAH-CAB-R2.....	95, 132
ODZ-MAH-CAB-R6.....	95, 132
ODZ-MAH-GRIP.....	95, 132
ODZ-MAH-GRIP1.....	95, 132
ODZ-MAH-GRIP2.....	95, 132
ODZ-MAH-GRIP3.....	95, 132
ODZ-MAH-PWR-CABL.....	95, 132
ODZ-MAH200-BRACKET.....	133
ODZ-MAH200-CHARGER.....	95, 132
ODZ-MAH200-CODEROUTER.....	96, 133
ODZ-MAH300 BRACKET.....	133

## R

RAM-101U.....	93
RAM-200-1.....	93
RAM-2461-Y906430.....	93
RTS-UP-1.....	127
RTS 16P.....	67, 127
RTS 1P DB9.....	127
RTS 4P DB9.....	67, 127
RTS 8P DB9.....	67, 127

## U

U-P3-R4.....	61
U-P3-RX.....	61
U-P3V4A-R4.....	61

U-P3V4A-RX.....	61
U-P4-R4.....	61
U-P4-R4-V15.....	61
U-P4-RX.....	61
U-P6-B5.....	61
U-P6-B5-V.....	61
U-P6-B6.....	61
U-P6-B6-V15B.....	61
U-P6V4A-B6.....	61

## V

V1-G-.6M-PUR ABG-V1-W.....	84
V1-G-10M-PUR.....	84
V1-G-10M-PUR ABG-V1-W.....	84
V1-G-10M-PVC.....	84
V1-G-20M-PUR ABG-V1-W.....	84
V1-G-2M-PUR.....	84
V1-G-2M-PVC.....	84
V1-G-5M-PUR.....	84
V1-G-5M-PUR ABG-V1-W.....	84
V1-G-5M-PVC.....	84
V1-G-IVH.....	85
V1-W-IVH.....	85
V15-G-YE10M-PVC-V15-G-ABG.....	86
V15-G-YE25M-PVC-V15-G-ABG.....	86
V15-G-YE5M-PVC-V15-G-ABG.....	86
V15B-G.....	90
V15B-G-0.6M-PUR ABG-V15B-G.....	90
V15B-G-12M-PUR ABG-V15B-G.....	90
V15B-G-15M-PUR ABG-V15B-G.....	90
V15B-G-1M-PUR ABG-V15B-G.....	90
V15B-G-2M-PUR ABG-V15B-G.....	90
V15B-G-5M-PUR ABG-V15B-G.....	90
V15B-G-7M-PUR ABG-V15B-G.....	90
V15SB-G.....	90
V1S-G-0.15M-PUR-SUBD.....	87
V1S-G-IVH.....	85
V1S-W-IVH.....	85
V45-G-10M-V45-G.....	88
VAZ-2FK-B3.....	86
VAZ-FK-R-BK.....	86
VAZ-FK-S-BK.....	86
VAZ-FK-ST1.....	86
VAZ-PB-CABLE.....	90
VAZ-PB-DB9-W.....	90
VAZ-R2-NULL.....	87
VAZ-R2-STRT.....	134
VAZ-RK-8163.....	87
VAZ-T1-FK-.3M-PUR-V1-G.....	86
VAZ-T1-FK-1M-PUR-V1-G.....	86

# SPOTLIGHT on Barcode Imaging Systems

## A Family of Solutions for Your Needs

Pepperl+Fuchs manufactures a broad range of barcode readers for a variety of applications. From collection of inventory data using wireless handhelds to high-speed readers capable of capturing rapidly moving packaging in an industrial environment, we have the right barcode imager for your application.



- Fixed-mount and handheld industrial imagers
- 1-D and 2-D barcode symbology
- Integrated package, built-in illumination
- Industry standard interfaces including many industrial networks & wireless

## Applications In:

- Material handling, warehousing, and inventory control
- Printing, labeling, sorting, bulk mailing, and inserting
- Automotive and allied industries
- Pharmaceutical & medical instrumentation
- Factory automation & electronics

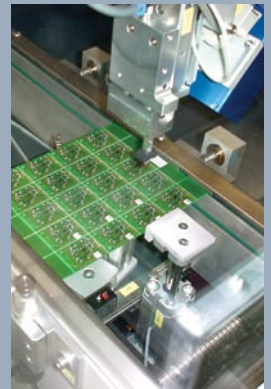

## Need Help Solving a Tough Application?

Pepperl+Fuchs wants to ensure that you receive the service and support you need when you need it, 24 hours every day. You can find CAD drawings, download product data sheets, or request free literature. Get it all on the web at [www.am.pepperl-fuchs.com](http://www.am.pepperl-fuchs.com).

## Need More? Ask an Expert.

With a click of the mouse, you can get advice from engineers who are experts in identification systems technology, who are familiar with a wide range of applications, and who can help you solve your most challenging production requirements. For reliable advice, visit [www.trustpf.com/ask](http://www.trustpf.com/ask) and ask an expert.

Visit us at [www.am.pepperl-fuchs.com](http://www.am.pepperl-fuchs.com) or call us at 330-486-0001

# FACTORY AUTOMATION – SENSING YOUR NEEDS



Pepperl+Fuchs sets the standard in quality and innovative technology for the world of automation. Our expertise, dedication, and heritage of innovation have driven us to develop the largest and most versatile line of industrial sensor technologies and interface components in the world. With our global presence, reliable service, and flexible production facilities, Pepperl+Fuchs delivers complete solutions for your automation requirements—wherever you need us.

## Contact

Pepperl+Fuchs Inc.  
1600 Enterprise Parkway  
Twinsburg, Ohio 44087 · USA  
Tel. +1 330 486-0001 · Fax +1 330 405-4710  
E-mail: [fa-info@us.pepperl-fuchs.com](mailto:fa-info@us.pepperl-fuchs.com)

## Worldwide Headquarters

Pepperl+Fuchs GmbH · Mannheim · Germany  
E-mail: [fa-info@de.pepperl-fuchs.com](mailto:fa-info@de.pepperl-fuchs.com)

## USA Headquarters

Pepperl+Fuchs Inc. · Twinsburg · USA  
E-mail: [fa-info@us.pepperl-fuchs.com](mailto:fa-info@us.pepperl-fuchs.com)

## Asia Pacific Headquarters

Pepperl+Fuchs Pte Ltd · Singapore  
Company Registration no. 199003130E  
E-mail: [fa-info@sg.pepperl-fuchs.com](mailto:fa-info@sg.pepperl-fuchs.com)

[www.am.pepperl-fuchs.com](http://www.am.pepperl-fuchs.com)

 **PEPPERL+FUCHS**  
SENSING YOUR NEEDS