

# INSTRUCTION MANUAL

**KE5A5-6H/2R-S (120 VAC)**

**KE5D2-6H/2R-S (24 VAC/VDC)**

**Safety Monitors**

**Original Instructions**



## Contents

<b>Introduction</b> .....	<b>3</b>
<b>Declaration of conformity</b> .....	<b>4</b>
<b>Information regarding EC conformity</b> .....	<b>4</b>
<b>Document purpose</b> .....	<b>4</b>
Scope.....	4
Delivery.....	5
Definitions.....	5
Symbols used.....	5
<b>General statements</b> .....	<b>5</b>
Qualified personnel.....	5
Intended use.....	6
Safety system test.....	6
<b>Product description</b> .....	<b>7</b>
Features.....	7
<b>Functions</b> .....	<b>7</b>
Power-up sequence.....	7
<b>Daily inspection</b> .....	<b>8</b>
Safety monitor (inputs).....	10
Reset faulted state.....	10
<b>Hardware</b> .....	<b>10</b>
Inputs.....	10
Indicators.....	11
Indicator status table.....	11
Guided relays.....	12
<b>Input devices</b> .....	<b>12</b>
Magnetic switches.....	12
Nominal offset distances.....	13
Device dimensions.....	13
<b>Installation</b> .....	<b>14</b>
Installation requirements.....	14
Clearance around the device.....	14
<b>General safety notes</b> .....	<b>14</b>
Installation and testing.....	14
<b>Electrical installation</b> .....	<b>15</b>
Powering the device.....	15
Wiring requirements.....	15
Wiring diagrams.....	16
Electrical connection.....	17
<b>Commissioning and startup</b> .....	<b>18</b>
Validation of the application.....	18
<b>Diagnostics</b> .....	<b>19</b>
Faults.....	19
Technical support.....	19
Troubleshooting.....	19
Fault diagnosis.....	19
Approvals.....	20
<b>Product specifications</b> .....	<b>20</b>
<b>Dimensions</b> .....	<b>23</b>

## **Introduction**

### **Congratulations!**

You have chosen a device manufactured by Pepperl+Fuchs. Pepperl+Fuchs develops, produces and distributes electronic sensors and interface modules for the market of automation technology on a worldwide scale.

Before you install this device and put it into operation, please read the instructions thoroughly. The instructions and notes contained in this operating manual will guide you step-by-step through the installation and commissioning procedures to ensure trouble-free use of this product. By doing so, you:

- Can utilize the entire range of device functions
- Reduce costs from downtime
- Increase the effectiveness and operating efficiency of your machine

Store this instruction manual somewhere safe in order to have it available for future reference. Directly after opening the packaging, please ensure that the device is intact and that the package is complete.

### **Copyright**

Copyright © 2017 by Pepperl+Fuchs, Inc.  
All rights reserved

The company Pepperl+Fuchs, Inc. claims copyright on this documentation. To modify, extend, hand over to a third party, or copy this documentation without written approval by the company, Pepperl+Fuchs, Inc. is expressly prohibited. Nor is any liability assumed for damages resulting from the use of the information contained herein. Further, this publication and features described herein are subject to change without notice.

The publisher reserves the right to alter the information and data contained in this manual without prior notice. Unless otherwise indicated, the company names as well as other names and data used in the examples are purely fictitious. The publisher may have registered patents or pending patent applications for subject matter covered in the manual. This manual does not give you license to these patents.

## Contact

If you have any questions about the device, its functions, or accessories, please contact your local Pepperl+Fuchs representative.

## Declaration of conformity

The KE5A5-6H/2RS and the KE5D2-6H/2RS safety monitors were developed and manufactured compliant with the applicable standards and guidelines.



Note



A corresponding declaration of conformity may be requested from the manufacturer.

## Information regarding EC conformity

Pepperl+Fuchs declares that the product described in this manual conforms with EC Directives by providing the following information:

Manufacturer	Pepperl+Fuchs GmbH, Lilienthalstraße 200, 68307 Mannheim, Germany, <a href="http://www.pepperl-fuchs.com">www.pepperl-fuchs.com</a>
Declaration of conformity	<a href="http://www.pepperl-fuchs.com">www.pepperl-fuchs.com</a>
Directives observed	2006/42/EC (Machinery Directive) 2014/30/EU (EMC Directive) 2014/35/EU (Low Voltage Directive)—Only for KE5A5-6H/2RS
Standards observed	EN ISO 13849-1:2015, EN 60664-1:2007, EN 61326-1:2013
Documentation officer	Pepperl+Fuchs GmbH, Lilienthalstraße 200, D-68307 Mannheim, Germany

## Document purpose

### Scope

The purpose of this document is to give the user the required information to properly apply and install the safety monitor. The product models covered under this document include the KE5D2-6H/2R-S and the KE5A5-6H/2R-S.

### Delivery

Included in the delivery:

- 1 - KE5A5-6H/2R-S or KE5D2-6H/2R-S safety monitor
- 5 - 50FY41 SIMMOD simulator modules
- 1 - Instruction manual

## Definitions

- **Input Device** – Externally mounted dual-channel switching device
- **Input** – Dual channel, redundant monitoring port
- **Qualified Personnel** – Persons trained in the use of the product, machinery, and system

## Symbols used



Warning

**This symbol warns of a danger.**

Failure to observe this warning may result in personal injury or death, property damage or destruction.



Attention

**This symbol warns of a possible fault.**

Failure to observe the instructions given in this warning may result in the device and any facilities or systems connected to it developing a fault or even failing completely.



Note

**This symbol draws your attention to important information.**

## General statements

### Qualified personnel

The door interrupt system is a safety product. However, just adding the door interrupt system to a machine or process will not meet safety standards. Functional Safety Management (FSM), considering a full lifecycle approach, must be used to guarantee functional safety. Competence is essential in the delivery of functional safety. The application must be planned by qualified personnel that know how to apply the necessary standards and regulations.

The safety monitor must be installed by qualified personnel who are properly trained in the installation and usage of the KE5D2-6H/2R-S and KE5A5-6H/2R-S products. These persons must have access to all instructions and knowledge of all required safety requirements regarding the application of such devices and machinery equipment.

Requirements:

- Manual must be read by persons using this equipment
- Device users must be trained and qualified in the use of safety-rated devices
- Users must learn and follow all the safety rules and operating principles in this manual
- Users must follow all warnings, cautions, and other safety messages in this manual
- Only original spare parts from Pepperl+Fuchs may be used for repairs

## Intended use

The safety monitor unit monitors up to six input devices. The external devices are individually wired to the safety monitor and the signals are evaluated to determine if one of the input devices is in the open state.



Note

The KE5D2-6H/2R-S and KE5A5-6H/2R-S safety monitoring system must be used in accordance with its intended purpose. The system must be installed according to regulations for safeguarding from hazardous locations or areas being entered, or as a safety relay for safety components appropriate for the described conditions. When used differently, the intended function of the system is not guaranteed. Appropriate measures should be taken such that any foreseeable misuse is prevented.

## Safety system test



Warning

**Only a qualified trained person should perform this test. Any problems detected as a result of this test must be repaired by qualified personnel before operating the equipment! DO NOT operate the equipment if problems are detected or serious injury could result!**

The purpose of this test is to verify the function of each switch and control component in the safety system. The person performing the test should be familiar with the different guards and controls on the equipment. This test should be performed daily. If the machine is not in continuous operation, test before each use. See the **Daily inspection** flow diagram, pages 8-9.

## Regular maintenance testing

It is recommended to test the safety monitor regularly to verify proper operation on a daily schedule. These should be performed and documented by qualified personnel. See test sequence, **Daily inspection**, pages 8-9.



Warning

**This safety device and associated equipment should be tested regularly by qualified personnel familiar with the principles and procedures in this manual.** If the testing indicates a problem with this device or system, the equipment is not safe to operate. Call qualified personnel immediately to locate and repair the fault.



Warning

**This safety device and associated equipment should be tested when any change or modification is done to the device and/or setup by qualified personnel familiar with the principles and procedures in this manual.** If the testing indicates a problem with this device or system, the equipment is not safe to operate. Call qualified personnel immediately to locate and repair the fault.

### Product description

#### Features

The KE5D2-6H/2R-S and KE5A5-6H/2R-S are category 3 PL d(ISO 13849-1:2015) safety monitors.

The basic features of the safety monitor include inputs for up to six individual two-channel switches for monitoring door access or guarded/monitored functions. Both channels are monitored and cross checked for proper operational switch states. The safety function monitors all switches, and they must have closed state conditions on both channels to allow the safety relay output to be energized.

- Monitored inputs (6)
- DIN rail mounting
- Dual N.O. output relay contacts
- Internal relay monitoring
- Removable screw terminals
- LED input indicators
- LED fault indicator
- LED relay status indicators
- LED relay power indicator

Together with the 50FY41 series sensors and 52FY31 series actuators, the safety monitor can be used to protect one or more points of hazardous areas.

### Functions

#### Power-up sequence

After power is applied to the safety monitor, an internal system check is performed verifying the functional logic and connected switch conditions. If any errors are detected at power-up, the safety output relays will remain in the de-energized state. Time to complete this internal verification is approximately two to three seconds.

Power-up state (safety relay energized):

- All internal function checks were verified and all input switch states are in the closed position

Power-up state safety function (safety relay de-energized):

- All internal function checks were verified, but one or more input switch states are in the open position
- One or more internal function checks fail

**Daily inspection**

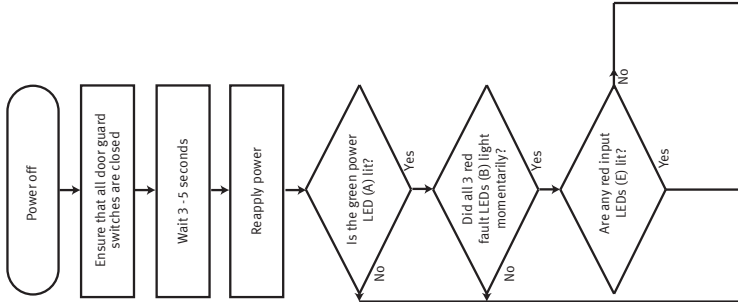

▲ Green LED  
■ Red LED

On Product	Description	Power LED	SR1 Gm LED	SR1 Red LED	SR2 Gm LED	SR2 Red LED	IN1	IN1a LED	IN1b LED	IN2	IN2a LED	IN2b LED	IN3	IN3a LED	IN3b LED	IN4	IN4a LED	IN4b LED	IN5	IN5a LED	IN5b LED	IN6	IN6a LED	IN6b LED	FAULT
	All guards closed	▲	▲																						
	Only input 1 open	▲		■				■																	■
	Only input 2 open	▲		■						■															■
	Only input 3 open	▲		■							■														■
	Only input 4 open	▲		■								■													■
	Only input 5 open	▲		■									■												■
	Only input 6 open	▲		■										■											■

Off at all times other than momentarily at power up

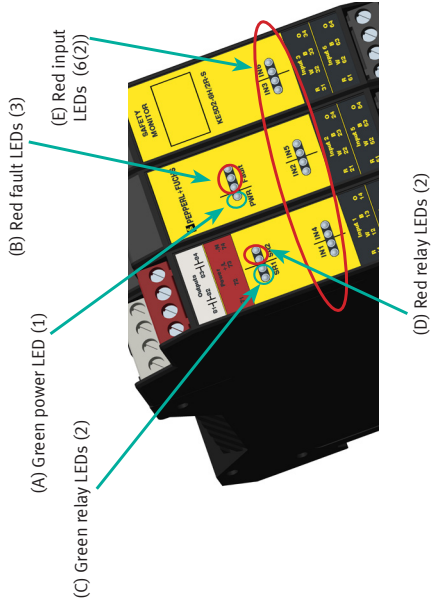



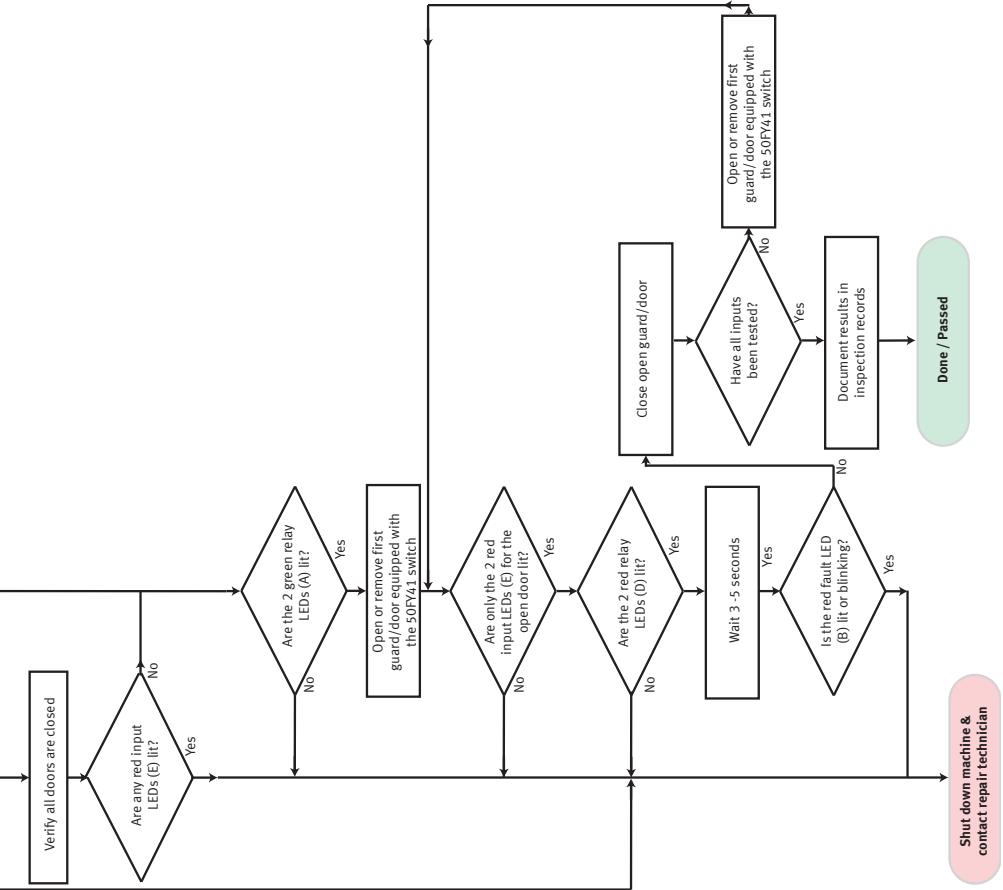

### Safety monitor (inputs)

The six device inputs allow the user to monitor up to six functional switch devices. Each device must have two channels of output, one sourcing output and one sinking output. These outputs must operate in tandem for a valid switch function to be recognized by the safety monitor. If the output channels of the switches are not functioning in a synchronized manner the safety amplifier will not accept the switch closure as a valid. The allowable timing between closure of switch channel A and channel B is approximately one second. If any given pair of switch channels does not transition to the proper state in the minimum time, then the monitor will issue a fault on that switch channel and prevent the output from closing.

### Reset faulted state

If an invalid door switch sequence is detected by the Channel A and Channel B synchronization, the safety relays will open and red fault LEDs will blink. Reset is accomplished by a monitor power down/power up sequence.

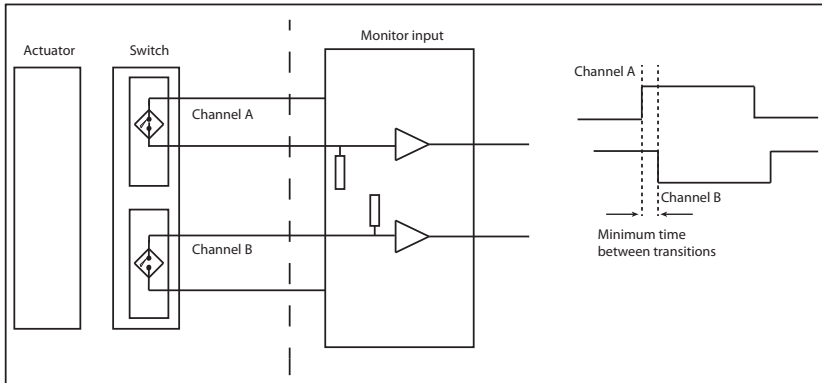

### Output relays to de-energize equipment



Attention

When an invalid input condition is recognized by the safety monitor, the output safety relay will be de-energized. This will cause the safety contact pair to open. Be sure to verify the contact power ratings when applying these relay outputs to energize/de-energize associated equipment.

## Hardware

### Inputs











- Six switch inputs compatible with dual channel devices
  - Pepperl+Fuchs' 50FY41 series magnetic sensors

### Indicators





The safety monitor has indicators on front of the device for the following functions:

- State of the connected input switches
  - ▶ Two indicators per switch input (channel A & channel B)
  - ▶ Indicator is illuminated (on) when the switch state is open
- Power On LED
  - ▶ LED is illuminated (on) when the unit power is applied
- Relay output status
  - ▶ Two indicators available, one per relay state:
    - Red indicator illuminated when de-energized
    - Green indicator illuminated when energized
- Fault Indicators
  - ▶ Fault indicator flashes under the following conditions:
    - Input switch sequence error (channel A and channel B timing)
    - ▶ Relay contact monitor fault

### Indicator status table

Condition		Switch Status		Relay 1 Status		Relay 2 Status		Red Fault LEDs	SR1/ SR2 Contact Status
		Red Channel 1 LED	Red Channel 2 LED	Red Open LED	Green Closed LED	Red Open LED	Green Closed LED		
Normal Operation	Door Sensor Open	■	■	■		■			
	Door Sensor Closed				▲		▲		
Faults	Door Sensor Fault <sup>1</sup>	■	■	■		■			
	Relay 1 Welded Contact Fault <sup>2</sup>				▲	■			
	Relay 2 Welded Contact Fault <sup>2</sup>			■			▲		
	Internal Relay Fault <sup>2</sup>			■		■			
Power Off									

1) Indicator status changes to fault 1-2 seconds after door fault is detected  
 2) Fault may require the next operational cycle to start before fault is indicated

 Green LED ON	 Red BLINKING	 OPEN
 Red LED ON	 OFF	 CLOSED

### Guided relays

The safety monitor incorporates two force-guided safety relays that are monitored for proper operation and generate a redundant output for application use.

### Input devices

#### Magnetic switches

The 50FY41 series hall effect door switches are a noncontact, magnetic actuation system consisting of a sensor and a magnetically keyed actuator. The sensor contains two hall-effect integrated circuits that are connected independently. When exposed to this magnetic actuator and properly aligned, the sensor responds with an output.

#### Approved devices



Attention

- 50FY41 series Hall effect door interrupt sensor
- 52FY31 series Keyed hall effect magnetic-actuator
- 50FY41-SIMMOD Simulator module for unused inputs

**NOTE:** These are the only approved devices that should be used.

#### Improper 50FY41 sensor alignment



Attention

Ensure the alignment of the sensor and magnetic actuator are correct for proper operation. A 10 mm (0.39 in) separation distance between sensor and actuator will cause an OFF condition, independent of axial offset distance.

#### Cable length



Attention

Sensor cable length must not exceed 25 m (80 ft).

Nominal offset distances

Sensing distance mm (in)		
Offset	Max. Actuator Distance	Off Distance
0 (zero)	2.5 (0.098)	10 (0.394)
3.5 (0.138)	1.3 (0.051)	10 (0.394)
4.0 (0.157)	0 (zero)	10 (0.394)

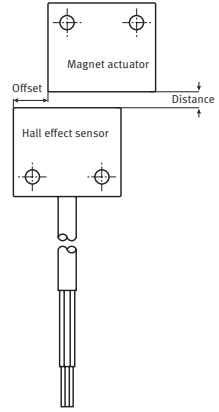

Device dimensions

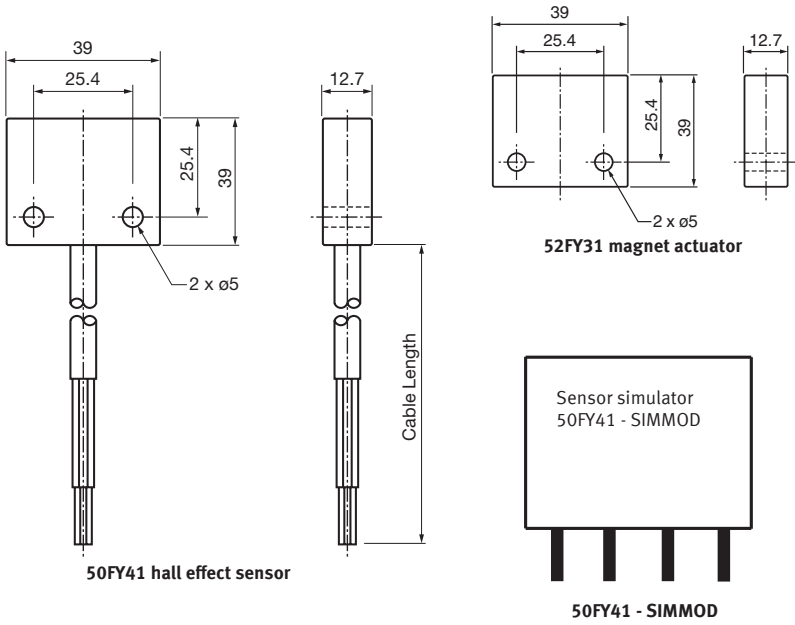

## Installation

### Installation requirements

DIN rail mounted inside an enclosure. The safety monitor is intended to be installed in a clean and dry environment. A control cabinet must be used to guarantee that the safety monitor is exposed to no worse than an IP20 environment. The unit is designed to meet the requirements for industrial environments. Suitability for other environments cannot be ensured.

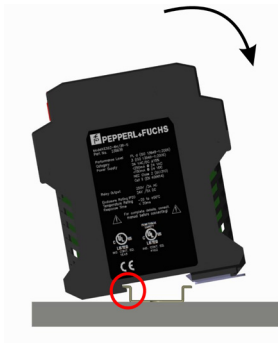

### Clearance around device

Adequate clearance should be provided around the device to allow for proper cooling and ventilation of the control unit.

## General safety notes

### Installation and testing

After installation, the safety monitor and all connected devices must be tested to ensure proper wiring and operation. All wiring should be verified before applying power to the unit. Once power is applied, each door switch should be opened to verify proper operation of the safety monitor.



Note

Periodic inspection and testing of the safety monitor is recommended. The device must be cycled and safety operation verified once per day, or between equipment usage cycles. During this time, proper operation of the safety switches and the correct response of output safety relays must be verified. Inspection records of the performed inspections must be maintained.

## Electrical installation



Warning

Switch the main machine power OFF prior to installation!  
The machine could inadvertently start during installation.  
The safety monitor fulfills the EMC requirements in accordance with 61326-3-2:2008 for safety related systems.

## Powering the device



Warning

Verify the model of the unit prior to connecting any power source.

**KE5D2-6H/2R-S** is to be powered only with **24 VAC or DC** with a supply variation of no greater than 15% (and for AC, a frequency of 45-62 Hz). The power supply must fulfill the standards for low voltage with double isolation (PELV with 24 VDC  $\pm$ 10%), for overvoltage category II according to EN 60664, or NEC Class 2 according to UL 1310.

**KE5A5-6H/2R-S** is to be powered only with **120 VAC** with a supply tolerance of no greater than 15% and a frequency of 45-65 Hz). The KE5A5 model complies with standard IEC 61010-1 Ed 3.0 2010-6, overvoltage category II.



Warning

All connected downstream devices and wiring/installation must correspond to the required category according to ISO 13849-1:2015.

## Wiring requirements

The safety monitor's terminals are color coded removable terminal blocks to provide assistance when wiring to the unit.

- RED terminal block : Input supply power
- GRAY terminal block : Relay contact outputs
- BLACK terminals : CH1 ... CH 6 50FY41 switch inputs



Warning

### Improper installation

This product is designed to conform to the technical requirements of ISO 13849-1:2015. To ensure compliance with these requirements, 50FY41 series sensors and 52FY31 series actuators **MUST** be used with the KE5D2-6H/2R-S and KE5A5-6H/2R-S safety monitors.

Consult with the local safety agency and its requirements when designing a machine control system, interface, and all control elements that affect safety. Strictly adhere to all installation instructions. **Failure to comply with these instructions could result in death or serious injury.**

Wiring diagram - KE5D2-6H/2R-S - 24 VAC/24 VDC

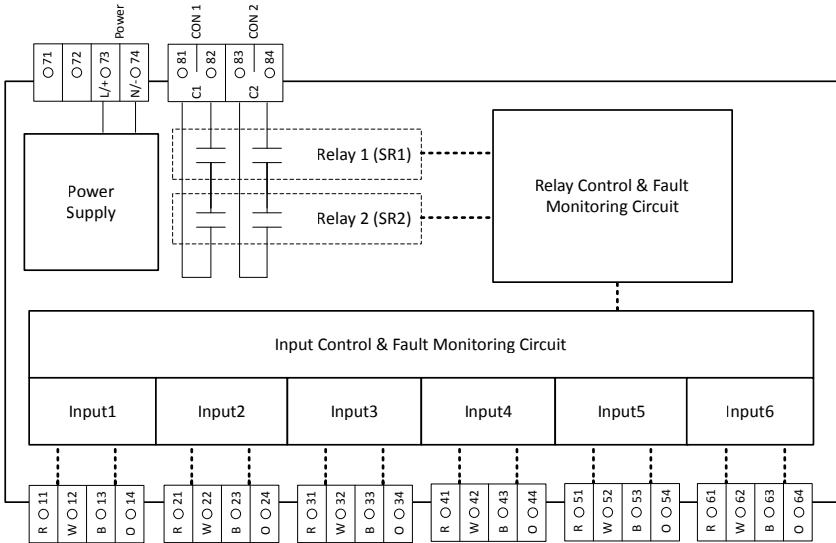

Wiring diagram - KE5A5-6H/2R-S - 120 VAC

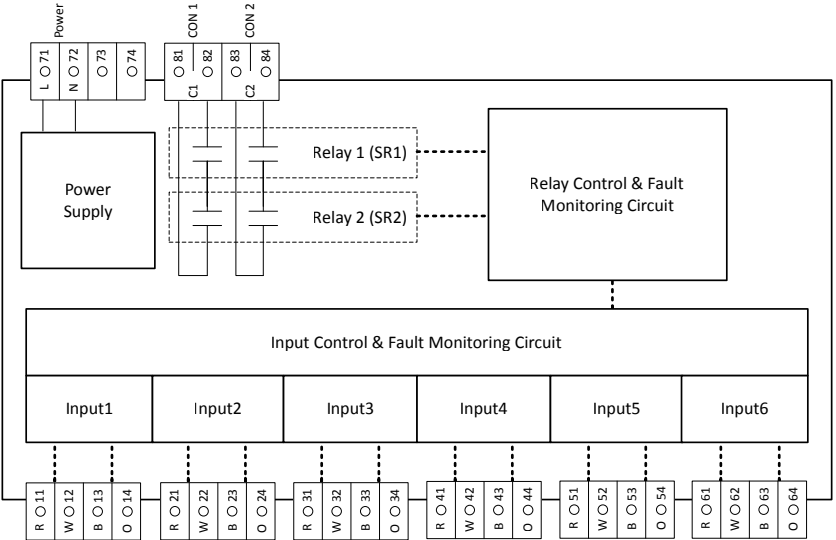



**Electrical connection**

Terminal	Monitor terminals	50FY41	Unused inputs
x1	R (positive)	RED - positive	Use sensor simulation module
x2	W (normally open, sourcing)	WHITE - output	
x3	B (negative)	BLACK - ground	
x4	O (normally open, sinking)	ORANGE - output	

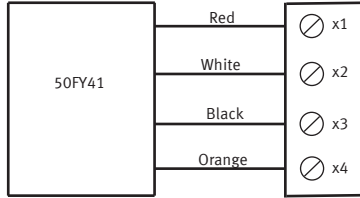

If less than six sensors are connected to the safety monitor, install a sensor simulator into the unused inputs.

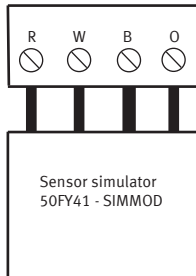

Warning

**Do not connect or remove terminal blocks with power applied.**

## Commissioning and startup



Warning

### **Do not commission without a check by qualified safety personnel!**

The safety monitor must be installed by qualified personnel who are properly trained in the installation, application, and usage of the KE5D2-6H/2R-S and KE5A5-6H/2R-S products.



Warning

### **You must ensure that no one is located in the hazardous area before commissioning!**

Check the hazardous area and secure it so that people cannot enter. For example, set up warning signs, attach blocking ropes or similar. Observe the relevant laws and local regulations.

## Validation of the application

You may commission the system only if all pretests were successful. Validation may be performed only by qualified personnel. The general acceptance comprises the following tests:

- Check whether the connection of the components used corresponds to the required Performance Level in accordance with EN ISO 13849-1:2015.
- Check that the devices connected to the safety monitor are in accordance with this user manual.
- Clearly mark all connection cables and plugs at the safety monitor.
- Perform a complete verification of the safety functions of the system in each operating mode and error simulation. Observe the response times of the system in response to tested functions.

## Diagnostics

### Faults

The safety monitor has multiple LEDs mounted on the top of the device to provide diagnostic and troubleshooting assistance. LEDs are provided for each switch input pair, indicating the status of the individual channel. Also provided are output LEDs indicating the status of each of the safety relays. In addition, fault LEDs provide indication of when an input switch error has occurred, resulting in a fault condition and opening of the safety relay. Fault conditions can be cleared only upon power down-power up, of the safety monitor.

## Technical support

### Troubleshooting

Problem	Probable cause	Remedy
Green power LED off	No supply power	Verify incoming power is present
		Verify removable screw terminal is fully installed
	Blown internal fuse	Verify Input power is within spec and then replace door switch monitor
Fault LED is flashing and single LED is lit for a sensor input while actuated or de-actuated	Misaligned sensor and actuator	Check alignment and realign as needed
	Input screw terminal loose	Fully install screw terminal
	Defective sensor	See <b>Fault diagnosis</b> (next page) to help determine problems
	Internal failure in door switch monitor	
All inputs activated (all input LEDs are off) and the relays do not activate	Defective safety monitor	Replace unit

### Fault diagnosis

If fault LED flashes and no sensor alignment problem can be found:

- Turn off power
- Unplug all input terminal blocks
- Power up unit

If fault LED begins to flash repeatedly after 2-3 seconds, the safety monitor needs to be replaced. If the fault LEDs do not begin to flash:

- Remove power, then plug in one input terminal block at a time. Apply power, waiting 2-3 seconds. Repeat sequence with all sensors until fault LED begins to flash. This will be the sensor/actuator that is generating the fault condition. Reevaluate alignment and terminal connections. If no problem is found, replace the sensor and/or actuator in question

Approvals

UL508
-------



Product specifications

Input specifications													
Nominal supply voltage KE5D2-6H/2R-S	24 VAC/VDC ± 15% <0.5A (for AC, frequency range is 48 to 62 Hz) (Power must be supplied by a Class 2 safety transformer or power supply)												
KE5A5-6H/2R-S	120 VAC ± 15% <0.25A @ 45 to 65 Hz												
Input devices	(6) dedicated noncontact hall effect door sensor (50FY41 series)												
Switch voltage input	12 VDC (2 channel, sink/source)												
Typical response time	20 ms (switch open to contact open)												
Power up time	3 s												
Output specifications													
Contact material	AgCuNi + 0.2-0.4um Au												
Continuous current	5 mA to 5 A (N.O. contact)												
Relay type	2 relay outputs, force guided connection, normally open contacts												
Inrush current (max)	30 A for 20 ms												
Maximum switching characteristics (Determined acc. to EN60947-4-1/EN60947-5-1)	<table> <tr> <td>AC-1: 250 V/3 A (100,000 cycles)</td> <td>120 V/5 A (125,000 cycles)</td> <td>24 V/5A (200,000 cycles)</td> </tr> <tr> <td>AC-15: 230 V/3 A (80,000 cycles)</td> <td>120 V/3 A (120,000 cycles)</td> <td>24 V/3 A (180,000 cycles)</td> </tr> <tr> <td>DC-1: 24 V/5 A (300,000 cycles)</td> <td></td> <td></td> </tr> <tr> <td>DC-13: 24 V/5 A /0.1 Hz (30,000 cycles)</td> <td></td> <td></td> </tr> </table>	AC-1: 250 V/3 A (100,000 cycles)	120 V/5 A (125,000 cycles)	24 V/5A (200,000 cycles)	AC-15: 230 V/3 A (80,000 cycles)	120 V/3 A (120,000 cycles)	24 V/3 A (180,000 cycles)	DC-1: 24 V/5 A (300,000 cycles)			DC-13: 24 V/5 A /0.1 Hz (30,000 cycles)		
AC-1: 250 V/3 A (100,000 cycles)	120 V/5 A (125,000 cycles)	24 V/5A (200,000 cycles)											
AC-15: 230 V/3 A (80,000 cycles)	120 V/3 A (120,000 cycles)	24 V/3 A (180,000 cycles)											
DC-1: 24 V/5 A (300,000 cycles)													
DC-13: 24 V/5 A /0.1 Hz (30,000 cycles)													

Product specifications (cont.)

Functional safety related parameters*	
Safety function	Relay output closed only when sensors activated by appropriate target
Safe state	Relay output open
Standards/regulations	ISO 13849-1 :2015/UL 508
Performance level acc. to ISO 13849-1	PL d
Structure acc. to ISO 13849-1	Category 3
MTTF <sub>d</sub> (years)	541
DC <sub>d</sub>	86 %
PFH	2.11 x 10E <sup>-7</sup>
CCF	5 %
T <sub>M</sub> (years)	20
Pollution degree	2
Over-voltage category	(OC) II
Rated insulation voltage	250 V
Protection degree	IP20, Class 1 “indoor use only”
Housing material	Polyamide (PA)
Internal hardware diagnostic fault detection	< 4 s

\*The following assumptions were made during the failure modes, effects, and diagnostic analysis (FMEDA) of the KE5D2-6H/2R-S and KE5A5-6H/2R-S:

- Failure rates are constant, wear out mechanisms are not included.
- Failure rates are based on the Siemens standard SN29500.
- Power supply failures are not included in the FMEDA, a loss of power introduces the safe state.
- It was assumed that the appearance of a safe error (e. g., output in safe state) would be repaired within 8 hours (e. g., remove sensor burnout).
- During the absence of the device for repairing, measures have to be taken to ensure the safety function (for example: substitution by an equivalent device).
- The stress levels are average for an industrial environment and can be compared to the Ground Fixed Classification of MIL-HDBK-217F. Alternatively, the assumed environment is similar to IEC 60654-1 Class C (sheltered location) with temperature limits within the manufacturer’s rating and an average temperature over a long period of time of 40 °C. Humidity levels are assumed within manufacturer’s rating. For a higher average temperature of 60 °C, the failure rates should be multiplied with an experience based factor of 2.5. A similar multiplier should be used if frequent temperature fluctuation must be assumed.

**Product specifications (cont.)**

<b>Ambient conditions</b>	
Operating temperature	-20 °C to +50 °C noncondensing
Storage temperature	-40 °C to +70 °C noncondensing
<b>Terminal block</b>	
Conductor cross section capacity	0.2 mm <sup>2</sup> to 2.0 mm <sup>2</sup> (24 to 14 AWG) Cu
Tightening torque	0.5 to 0.6 Nm (4.5 to 5.3 lb-in)
Strip length	7 mm
Connection method	Removable terminal block - screw connection
<b>General data</b>	
Dimensions	
KE5D2-6H/2R-S	99.0 mm H x 67.8 mm W x 111.0 mm D
KE5A5-6H/2R-S	99.0 mm H x 90.4 mm W x 111.0 mm D
Mechanical service life (approx.)	>1,000,000 operations
Indicators	
Power	LED green
Sensor status	LED red, one per channel / two per input
Relay status	LED green (2), red (2)
Fault status	LED red, flashing
	(See indicator status table, pg 11, for indication definitions)

Dimensions



KE5D2-6H/2R-S  
24 VAC/DC

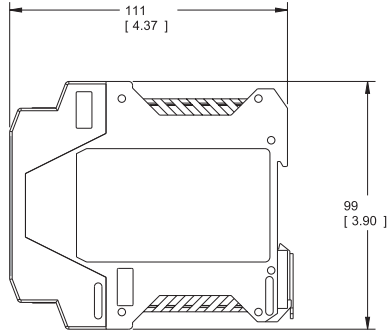
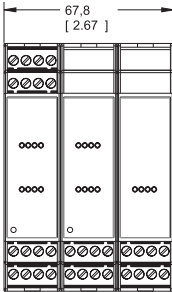

KE5A5-6H/2R-S  
120 VAC

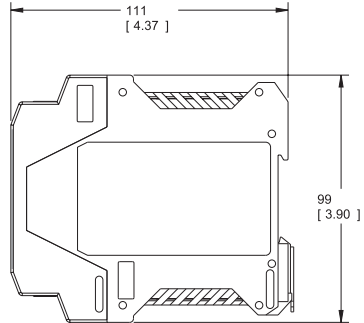
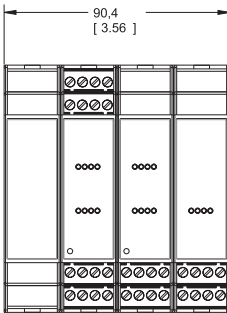

# Your automation, our passion.

## Explosion Protection

- Intrinsically Safe Barriers
- Signal Conditioners
- Fieldbus Infrastructure
- Remote I/O Systems
- HART Interface Solutions
- Wireless Solutions
- Level Measurement
- Purge and Pressurization Systems
- Industrial Monitors and HMI Solutions
- Electrical Explosion Protection Equipment
- Solutions with Explosion Protection

## Industrial Sensors

- Proximity Sensors
- Photoelectric Sensors
- Industrial Vision
- Ultrasonic Sensors
- Rotary Encoders
- Positioning Systems
- Inclination and Acceleration Sensors
- AS-Interface
- Identification Systems
- Logic Control Units
- Connectivity



### North/Central American Headquarters

Pepperl+Fuchs Inc.  
Twinsburg · Ohio · USA  
Tel. +1 330 486 0002  
E-Mail: [fa-info@us.pepperl-fuchs.com](mailto:fa-info@us.pepperl-fuchs.com)