

5500 Purge System User Manual

Bebco EPS® 5500 Series Type Z and
Ex pzc Purge and Pressurization System



With regard to the supply of products, the current issue of the following document is applicable:
The General Terms of Delivery for Products and Services of the Electrical Industry, published by the
Central Association of the Electrical Industry (Zentralverband Elektrotechnik und Elektroindustrie
(ZVEI) e.V.) in its most recent version as well as the supplementary clause: "Expanded reservation of
proprietorship".

Worldwide

Pepperl+Fuchs Group
Lilienthalstr. 200
68307 Mannheim
Germany

Phone: +49 621 776 - 0
E-mail: info@de.pepperl-fuchs.com

North American Headquarters

Pepperl+Fuchs Inc.
1600 Enterprise Parkway
Twinsburg, Ohio 44087
USA

Phone: +1 330 425-3555
E-mail: sales@us.pepperl-fuchs.com

Asia Headquarters

Pepperl+Fuchs Pte. Ltd.
P+F Building
18 Ayer Rajah Crescent
Singapore 139942

Phone: +65 6779-9091
E-mail: sales@sg.pepperl-fuchs.com
<https://www.pepperl-fuchs.com>

Table of contents

1. Introduction.....	6
1.1. Content of this Document	6
1.2. Target Group, Personnel.....	7
1.3. Symbols Used.....	8
1.4. Pertinent Laws, Standards, Directives, and Further Documentation.....	9
1.5. Declaration of Conformity.....	9
2. Product Description	10
2.1. Introduction	10
2.2. 5500 System Overview	10
2.3. Control Unit.....	10
2.3.1 Technical Data: Control Unit	11
2.3.2 Electrical Connections.....	17
2.3.3 Dimensions	18
2.3.4 Hardware Kit	21
2.3.5 Torque Requirements: Control Unit.....	21
2.3.6 Internal-Mounting the Control Unit.....	22
2.3.7 External-Mounting the Control Unit	23
2.4. EPV-5500 Vents	24
2.4.1 Technical Data: EPV-5500 Vents	24
2.4.2 Flow Rate Curves.....	26
2.4.3 Dimensions: EPV-5500 Vents	30
2.4.4 Torque Requirements: EPV-5500 Vents.....	30
2.5. Manifold Valves	30
2.5.1 Technical Data: 5500 Manifolds.....	32
2.5.2 Dimensions: 5500 Manifolds	34
2.5.3 Torque Requirements: Manifolds.....	36
3. Installation and Operation	37
3.1. Installation.....	37
3.1.1 For Gas Atmospheres	37
3.1.2 For Dust Atmospheres.....	38
3.1.3 Setting up the System	38
3.2. Operation.....	39

4. Programming	40
4.1. User Interface	40
4.1.1 LED Indication.....	40
4.1.2 Buttons.....	41
4.1.3 Adjusting the Contrast	41
4.1.4 LCD Backlight	41
4.2. Default Settings.....	42
4.3. Menu Structure	43
4.4. Purge Programs.....	44
4.4.1 Program 1.....	45
4.4.2 Program 2.....	46
4.4.3 Program 3.....	47
4.4.4 Program 4.....	48
4.4.5 Program 5.....	49
4.5. Purging Timer.....	50
4.5.1 Determining Purge Time.....	50
4.5.2 Pressure Settings	52
4.5.2.1 Minimum Enclosure Pressure “P1”	52
4.5.2.2 Alarm Pressure “P2”.....	52
4.5.2.3 Purging Pressure “P3”.....	53
4.5.2.4 Maximum Internal Pressure “P4”.....	53
4.5.3 Programming K2	55
4.6. Shutoff Delay Timer for K1	56
4.7. Number of PT100 Temperature Sensors Used.....	57
4.8. Temperature Inputs PT1 and PT2.....	58
4.9. Bypass	59
4.10. Units	60
4.11. Temp Enabled.....	60
4.12. Change Password.....	61
4.13. User Parameter Setting Sheet	62
5. Product Identification	63
5.1. Specific Conditions of Use.....	63
5.2. Applied Standards and Markings	63
5.3. Type Codes	64
5.4. Markings (Labelling)	65

6. Product Lifetime Care	67
6.1. Maintenance and Repair.....	67
6.2. Dismantling and Decommissioning.....	67
6.3. Troubleshooting.....	68

1. Introduction

1.1. Content of this Document

This document contains information required to meet the safety and protection requirements for systems with explosion protection in equipment Group II Zones 2 or 22, Class I or II, Division 2 when installing, commissioning, and using the 5500 control unit and its components. This important information will help you use the 5500 purge and pressurization system safely and correctly.

This may include information on the following:

- Product identification
- Delivery, transport, and storage
- Mounting and installation
- Maintenance and repair
- Disposal

Knowledge of the basic safety regulations and additional training and experience in the area of explosion protection are essential for the safe handling and failure-free operation of the 5500 series purge and pressurization system.

These operating instructions contain important data and information to ensure the safe use of the 5500 system in hazardous areas and to meet the requirements of Directive 2014/34/EU. This manual, particularly the safety information, must be followed by all personnel who work on the system.



WARNING!

Failure to follow these instructions may impair the safety protection and function of the equipment.



Note

For complete information on this product, see further documentation at www.pepperl-fuchs.com.

Information about individual components can be provided on request.

The documentation comprises the following parts:

- This document
- Safety instruction manual
- Datasheet

In addition, the documentation may comprise the following parts, if applicable:

- Manufacturer declaration of conformity
- EU declaration of conformity
- Control drawings
- Additional documents

1.2. Target Group, Personnel

Responsibility for planning, assembly, commissioning, operation, maintenance, and dismantling of the 5500 series lies with the plant operator. Personnel working on this system must:

- be familiar with the occupational safety and accident prevention regulations and have been briefed regarding handling of the unit.
- have the additional knowledge of explosion protection that is required for work on explosion-protected components.
- be familiar with the relevant rules and regulations for the installation, operation, and maintenance of explosion-protected systems.
- have read the safety section and warnings in this manual.

The operator and/or installer must also ensure that:

- the 2-wire RTDs for temperature sensors are suitable for the area classification, Zone 2, or Zone 22, Class I, Zone 2. Maximum length is 3m.
- the bypass switch is suitable for the area classification, Zone 2 or Zone 22, Class I, Zone 2.
- the intrinsically safe aspects of the system are installed in accordance with manufacturer's control drawing number 116-B026.
- that the 5500 system is used as a purge controller and not protected by purging and pressurization
- all electrical, mechanical, and pneumatic connections have been made in accordance with this manual and any other applicable standards and laws.

1.3. Symbols Used

This document contains symbols to identify warning messages and information messages.

Warnings

You will always find warning messages whenever hazards could result from your actions. It is essential that you observe these warning messages to ensure your personal safety and to prevent property damage.

Warning messages are shown in descending order according to the risk level, as follows:



DANGER!

This symbol warns you of an immediate and present danger.

If you do not observe this warning message, there is a risk of personal injury and even death.



WARNING!

This symbol warns you of a potential fault or hazard.

If you do not observe this warning message, there is a risk of personal injury or severe property damage.



CAUTION!

This symbol warns you of a potential fault.

Failure to observe this warning message may result in the malfunctioning or complete failure of the product or any systems and plants connected to it.

Information Symbols and Messages



Note

This symbol draws your attention to important information.



Action instructions

This symbol highlights an action. You are prompted to perform an action or sequence of actions.

1.4. Pertinent Laws, Standards, Directives, and Further Documentation

NEC, CEC, and other national and local laws, standards, or Directives that are applicable to the intended use and installation location must be observed. In relation to hazardous areas, Directive 1999/92/EC must be observed.

The corresponding datasheets, EU Declaration of Conformity, EU Type Examination Certificates, NEC/NFPA and CEC certificates, and control drawings, if applicable (see datasheet), are an integral part of this document. You can find this information at www.pepperl-fuchs.com.

Due to constant revisions, documentation is always subject to change. Please refer only to the most up-to-date version, which can be found at www.pepperl-fuchs.com.

1.5. Declaration of Conformity

All products were developed and manufactured under observance of the applicable European standards and guidelines.

i

Note

A Declaration of Conformity is included with these instructions and can be requested from the manufacturer or obtained online at www.pepperl-fuchs.com. Additional documentation can also be provided for individual components.

The product manufacturer, the Pepperl+Fuchs Group, 68307 Mannheim, has a certified quality assurance system that conforms to ISO 9001.



ISO9001

2. Product Description

2.1. Introduction

Purge and pressurization is one of the most versatile ignition protection classes. Purge and pressurization systems are based on the principle that in Zone 2/Class I Division 2 (gas), the gas mixture in the ambient atmosphere, which may ignite under certain circumstances, is removed from the housing by an initial purge process. After the purge phase, sufficiently compressed inert gas, usually air, is supplied to compensate for leaks in the housing and any installed equipment. This permanent overpressure prevents any potentially explosive atmosphere in the ambient air from entering the housing. During the purge phase, an internal pressure is achieved.

Any hot spots that may occur on individual components in the control cabinet are monitored by temperature sensors (optional) and switched off safely if necessary. This ensures that no unacceptably high surface temperatures can reach the exterior.

For applications in Zone 22/Class II Division 2 (dust), the purge process is omitted because purging would raise explosive dust into a cloud, creating a possible hazard. Instead of pre-purging, the interior of the housing is inspected for dust and cleaned manually if dust is present.

Purge and pressurization systems are particularly suitable for installed equipment that is not approved for use in hazardous areas. The equipment can then be used directly in the hazardous area.

2.2. 5500 System Overview

The 5500 series system consists of a control unit with a user interface mounted in a 316 stainless steel enclosure. The control unit works in conjunction with enclosure protection vents (EPVs) and pneumatic solenoid valves or manual valves.

The 5500 is a purge/pressurization controller and is not protected by pressurization.

2.3. Control Unit

The 5500 control unit is a control device for Type Z and Ex pzc purge systems. The unit is suitable for purge time and pressure monitoring in Class I or II, Division 2, Zone 2 or 22. It controls the volume of purge gas flowing into the protected control cabinet, and it maintains and monitors an overpressure relative to the ambient air when purging is complete.

The 5500 control unit can be ordered for internal or external mounting with different optional cable glands and conduit fittings for easy and approved wiring methods.



Control Unit Components

- 5500 control unit
- Cable glands / conduit openings available
- Mounting bolts and sealing washers for attaching control unit to an enclosure
- Hardware for the reference pressure—bulkhead fitting, sealing washer, and tubing
- Manual

2.3.1 Technical Data: Control Unit

Item	Value
Supply	
Rated voltage U_r	100 ... 240 V AC, 0.05 A, 50 ... 60 Hz 20 ... 30 V DC, 0.2 A Overvoltage category II
Power consumption	100 ... 240 V AC - 2.3 VA (without digital valve) 20 ... 30 V DC - 2.5 W (without digital valve)
Electrical Specifications	
Fuse Rating	F2: AC: 2 A slow blow, 5 x 20 mm DC: 3.15 A slow blow, 5 x 20 mm F1: AC: 0.08 A (max) slow blow, 5 x 20 mm DC: 0.5 A (max) slow blow, 5 x 20 mm Fuse must be UL Recognized under JDYX2/8

Input	
Input I	Temperature, up to 2 RTDs per unit
Connection	PT100, 2-wire-connection
Input type	temperature input
Input accuracy	2.5% of measurement value + PT100 error
Input II	1 Bypass
Connection	passive contact (switch)
Input type	mechanical contact
Output	
Output I	
Connection	K1, terminals: K1/N0, K1/N0
Output type	enclosure power, (1) SPST
Inrush current	6 A
Contact loading	6 A at 250 V AC, 30 V DC resistive load, 6 A at 30 V DC
Output II	
Connection	K2, terminals: K2 (NO, C, NC)
Output type	alarm, (1) SPDT
Inrush current	3 A
Contact loading	3 A at 250 V AC , 30 V DC resistive load, 3 A at 30 V DC
Output III	
Connection	digital valve, terminals SV
Output type	(1) SPST, powered contacts from supply 5 A V AC or V DC
Inrush current	5 A
Indicators/settings	
LED indication	Membrane Pad K1: Green–Contact K1 is energized K2: Amber–Contact K2 is energized SV/encl press.: Blue for safe pressure, Amber for valve on Bypass: Amber when bypass is active PT100 error: Red when fault in PT100 sensor
Safe pressure programmable	
Protective gas supply	instrument grade air or inert gas
Safe pressure, programmable	Gas: 0.7 mbar (0.3 in wc) Dust: 1.6 mbar (0.65 in wc)
Directive conformity	
Electromagnetic compatibility	
Directive 2014/30/EU	EN 61326-1:2013

RoHS	
Directive 2011/65/EU	EN 50581:2012
Conformity	
Degree of protection	EN 60529
Shock resistance	EN 60068-2
Ambient conditions	
Ambient temperature	-20 ... 40 °C (-4 ... 104 °F) at T6 -20 ... 60 °C (-4 ... 140 °F) at T4
Relative humidity	5 ... 95 %, non-condensing
Altitude	max. 2000 m
Vibration resistance	5 ... 100 Hz , 1 g, 12 m/s ² , all axes
Impact resistance	30 g, 11 ms, all axes
Mechanical Specifications	
Connection type	High pressure port: 1/8" NPTF Low pressure port: 1/8" NPTF
Cable gland	Cable size M12 diameter 3–6.5mm RTD/Bypass: (3) M12x1.5 M20 diameter 10–12mm K1, K2, SV: 'P_C' (3) M20x1.5
Degree of protection	Type 4X IP66 (Device is protected against dust and strong jets of water.)
Pollution degree	Device can be installed in environments up to pollution degree 2.
Material	Housing: 316 stainless steel Cable Gland: 316 stainless steel or Nickel Plated Brass Pressure Ports: 316 stainless steel Membrane Pad: Autotex F200XE O-ring: EPDM
Mass	approx. 2.7 kg (6 lb)
Dimensions	165 x 124 x 90 mm (6.5 x 4.9 x 3.5 in)
Mounting control unit (Internal/External)	Mounting holes (3x 6.4mm) Screws, nuts, and sealing washers (provided)
Data for application in connection with hazardous areas	
Certificate	DEMKO 14 ATEX 1282X

Marking	<p>⊕ II 3 (3) G Ex ic ec nC [ic Gc] [pzc Gc] IIC T4 Gc (-20 °C ≤ Ta ≤ 60 °C)</p> <p>⊕ II 3 (3) G Ex ic ec nC [ic Gc] [pzc Gc] IIC T6 Gc (-20 °C ≤ Ta ≤ 40 °C)</p> <p>⊕ II 3 (3) D Ex ic tc [ic IIIC Dc] [pzc Dc] IIIB T80 °C Dc (-20 °C ≤ Ta ≤ 60 °C) (external version)</p> <p>⊕ II 3 (3) D Ex ic tc [ic IIIC Dc] [pzc Dc] IIIB T60 °C Dc (-20 °C ≤ Ta ≤ 40 °C) (external version)</p> <p>⊕ II 3 (3) D Ex ic tc [ic Dc] [pzc Dc] IIIC T80 °C Dc (-20 °C ≤ Ta ≤ 60 °C) (internal version)</p> <p>⊕ II 3 (3) D Ex ic tc [ic Dc] [pzc Dc] IIIC T60 °C Dc (-20 °C ≤ Ta ≤ 40 °C) (internal version)</p>
Directive conformity	
Directive 2014/34/EU	EN IEC 60079-0:2018, EN 60079-11:2012, EN 60079-15:2019, EN 60079-2:2014, EN 60079-7:2015+A1:2018, EN 60079-31:2014
International approvals	
UL approval	
cULus	<p>UL File E184741</p> <p>Class I, Division 2, Groups A, B, C, D T4 (-20 °C ≤ Ta ≤ 60 °C)</p> <p>Class II, Division 2, Groups F, G, T4 (-20 °C ≤ Ta ≤ 60 °C)</p> <p>Class I, Division 2, Groups A, B, C, D T6 (-20 °C ≤ Ta ≤ 40 °C)</p> <p>Class II, Division 2, Groups F, G T6 (-20 °C ≤ Ta ≤ 40 °C)</p>
IECEx approval	<p>IECEx UL 14.0019X</p> <p>Ex ic ec nC [ic Gc] [pzc Gc] IIC T4 Gc (-20 °C ≤ Ta ≤ 60 °C)</p> <p>Ex ic ec nC [ic Gc] [pzc Gc] IIC T6 Gc (-20 °C ≤ Ta ≤ 40 °C)</p> <p>Ex ic tc [ic IIIC Dc] [pzc Dc] IIIB T80 °C Dc (-20 °C ≤ Ta ≤ 60 °C) (external version)</p> <p>Ex ic tc [ic IIIC Dc] [pzc Dc] IIIB T60 °C Dc (-20 °C ≤ Ta ≤ 40 °C) (external version)</p> <p>Ex ic tc [ic Dc] [pzc Dc] IIIC T80 °C Dc (-20 °C ≤ Ta ≤ 60 °C) (internal version)</p> <p>Ex ic tc [ic Dc] [pzc Dc] IIIC T60 °C Dc (-20 °C ≤ Ta ≤ 40 °C) (internal version)</p>

Bypass and Temperature Wiring Notes

1. The minimum wire strand in a stranded wire shall have a diameter of 0.1 mm or greater.
2. Wire shall be copper only, rated at a minimum of 80 °C.
3. Minimum wire insulation thickness shall be 0.25 mm for each conductor.
4. Terminal torque is 0.22–0.25 Nm.
5. The wire strip length is 7 mm.
6. There shall be only one wire per terminal.

Item	Value
Cable gland 'L_C'	(3) M12 x 1.5 Cable size: M12 dia 3–6.5 mm
Material	316 stainless steel or nickel-plated brass, O-ring EPDM
Conductor cross section, solid min.	0.14 mm ²
Conductor cross section, solid max.	1.5 mm ²
Conductor cross section, stranded min.	0.14 mm ²
Conductor cross section, stranded max.	1.5 mm ²
Conductor cross section, with ferrule without plastic sleeve, min.	0.25 mm ²
Conductor cross section with ferrule without plastic sleeve, max.	1.5 mm ²
Conductor cross section with ferrule, with plastic sleeve, min.	0.25 mm ²
Conductor cross section, with ferrule, with plastic sleeve, max.	0.5 mm ²
Conductor cross section, AWG/kcmil min.	28
Conductor cross section, AWG/kcmil max.	16

Control Power Connection General Wiring Notes

1. All applicable local and national wiring codes must be followed when wiring the system. See IEC 60079-14 for more information.
2. The power supply to this device shall have a separate disconnect. If placed in the hazardous area, it shall be rated for the area in which it is being installed. Placing the disconnect into the purged enclosure is not a “safe” area since power needs to be applied to the control unit before the purge cycle is complete.
3. The protective earth wire must be the same size as largest wire used to bring power into the enclosure. Terminate using a ring lug that is properly crimped at the protective earth stud in the bottom of the enclosure.

4. For earth stud torque and terminal torque values, see Section 2.3.5 Torque Requirements—Control Unit.
5. All wire shall be copper only, rated at a minimum of 80 °C.
6. The minimum wire strand in a stranded wire shall have a diameter of 0.1 mm or greater.
7. The wire strip length into the fixed terminal block is 8 mm.
8. There shall be only one wire per terminal.
9. It is recommended to leave a bit of extra wire loop in the housing.

Connector Component	Property
Cable gland 'P_C'	(3) M20 x 1.5 Cable size: M20 dia
Clamping range	single seal: 14.5 ... 16 mm double seal: 12 ... 14.5 mm triple seal: 10 ... 12 mm
Material	316 stainless steel or nickel-plated brass, O-ring EPDM
Conduit "PSH"	(3) 1/2" NPTF
Material	316 stainless steel or nickel-plated brass, O-ring EPDM
Conductor cross section, min.	0.2 mm ²
Conductor cross section, max.	6 mm ²
Conductor cross section, stranded min.	0.2 mm ²
Conductor cross section, stranded max.	4 mm ²
Conductor cross section, with ferrule without plastic sleeve, min.	0.25 mm ²
Conductor cross section with ferrule without plastic sleeve, max.	2.5 mm ²
Conductor cross section with ferrule, with plastic sleeve, min.	0.25 mm ²
Conductor cross section, with ferrule, with plastic sleeve, max.	4 mm ²
Conductor cross section, AWG/kcmil min.	24
Conductor cross section, AWG/kcmil max.	10

2.3.2 Electrical Connections

External Mount

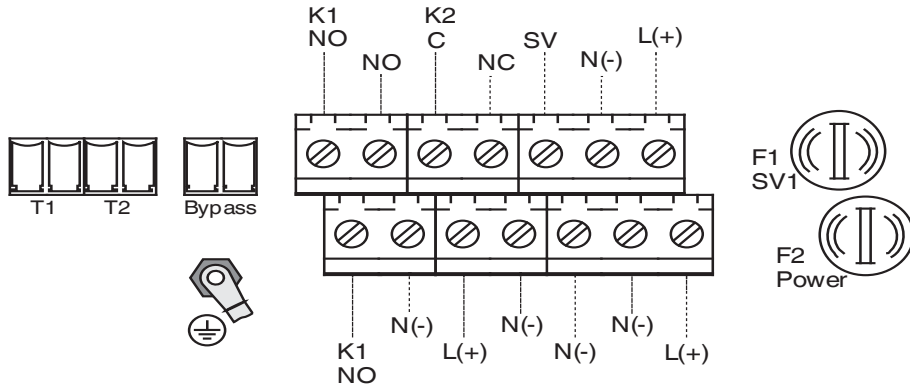

Internal Mount

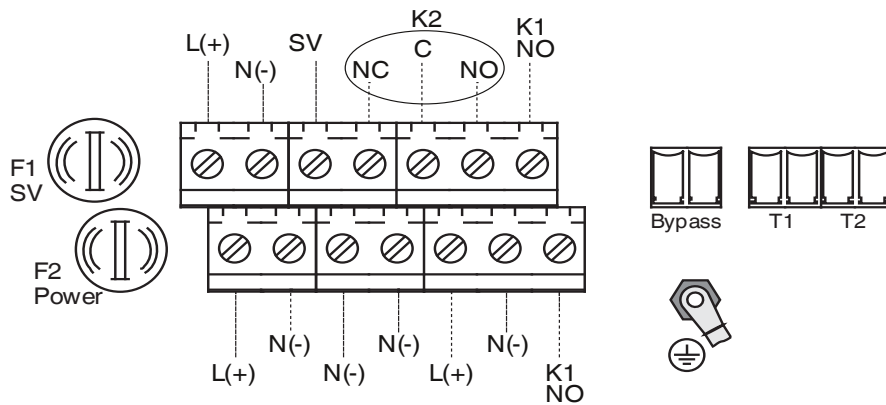

Terminal Block

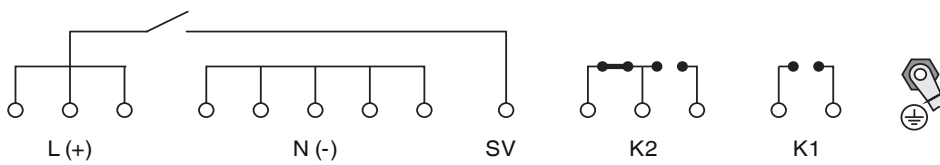

2.3.3 Dimensions

Dimensions: External Mounting

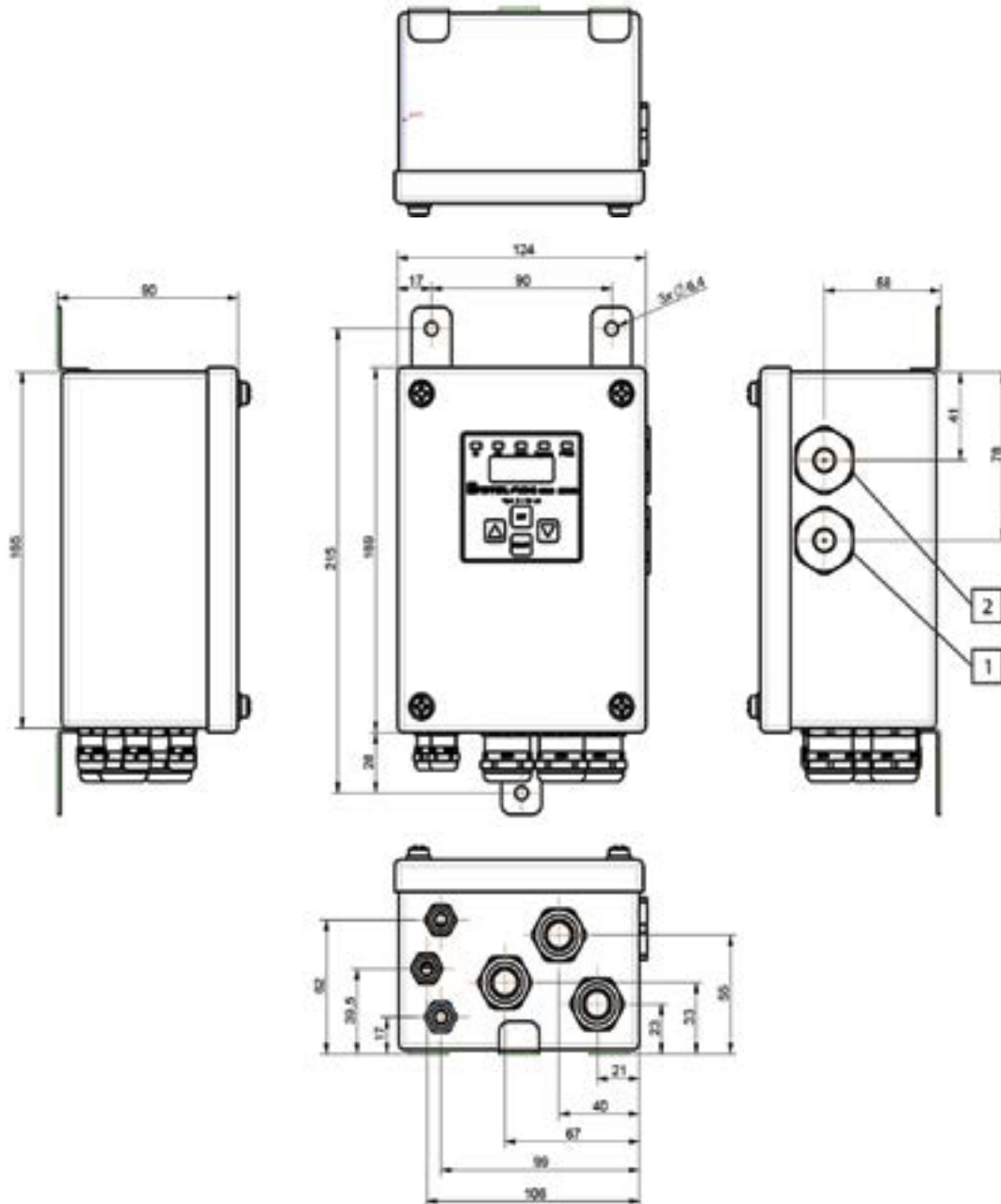

1. **Low pressure port (-):** The atmospheric reference. This port shall always be connected such that the air pressure present on this port is the atmospheric pressure surrounding the enclosure being protected by pressurization. For monitoring the enclosure pressure.
2. **High pressure port (+):** For monitoring the enclosure pressure. This port must always connect the control unit to the monitored enclosure protected by pressurization.

For the external-mount 5500 control unit, the display can be rotated 90 degrees. No screws are required. To rotate, remove the cover and pop out the display. Position the display as desired and push it back into the pin on the control unit. Do not rotate more than +/- 90 degrees. When rotating the display, be careful not to collapse the tubing by bending in extreme angles.

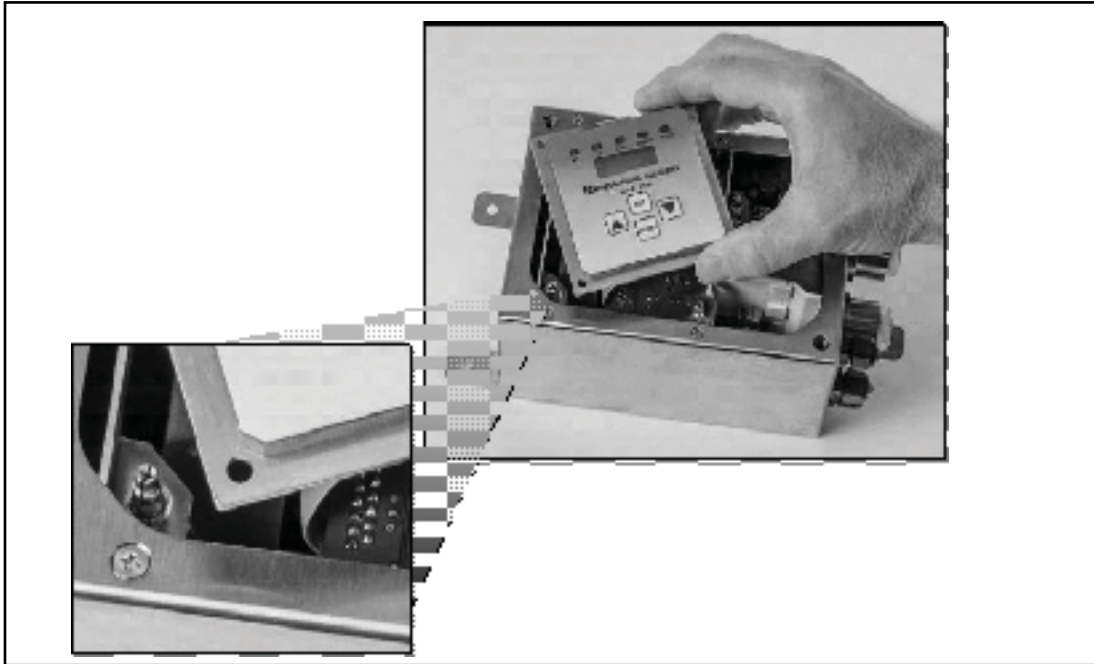

Dimensions: Internal Mounting

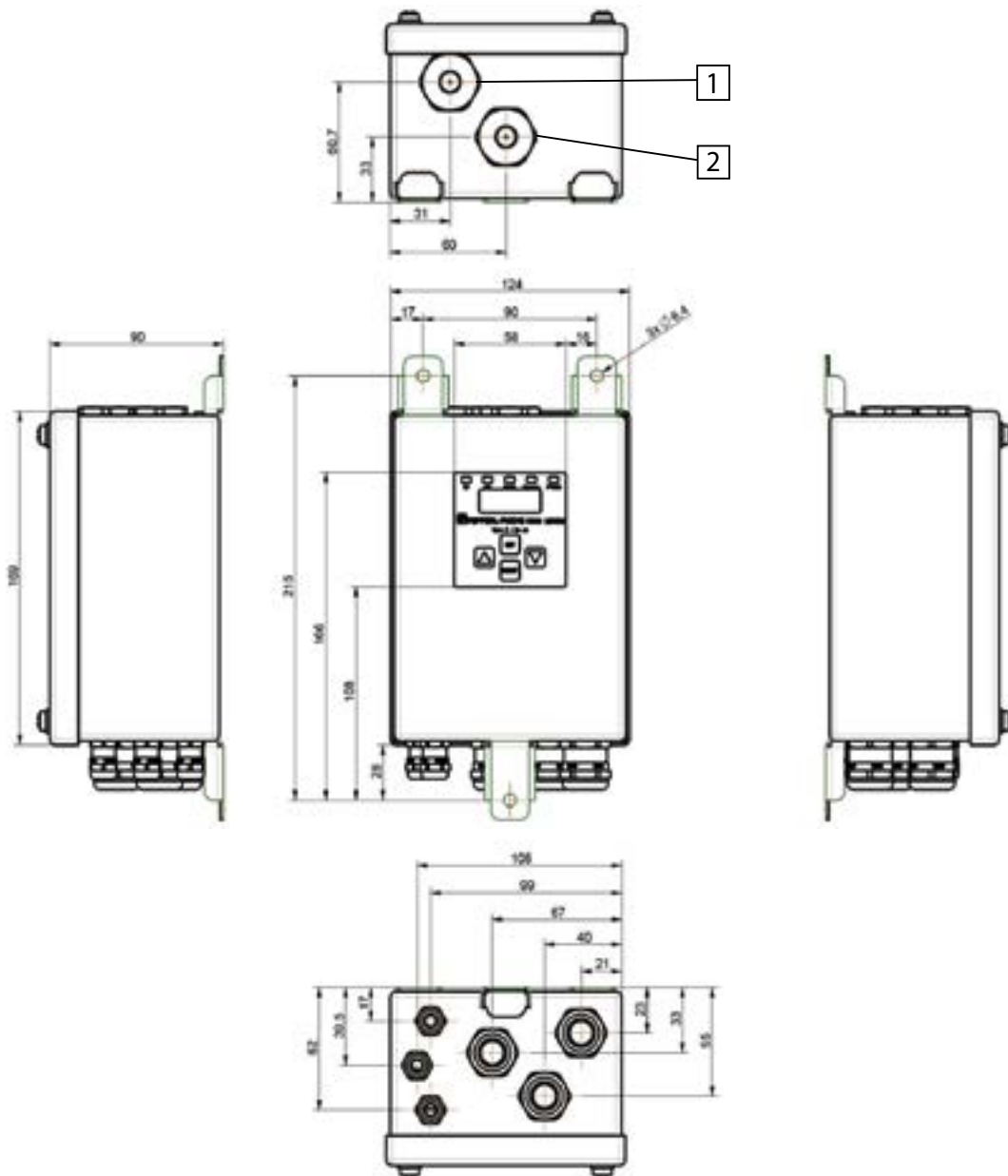

1. **Low pressure port (-):** The atmospheric reference. This port shall always be connected such that the air pressure present on this port is the atmospheric pressure surrounding the enclosure being protected by pressurization.
2. **High pressure port (+):** For monitoring the enclosure pressure. This port must always connect the control unit to the monitored enclosure protected by pressurization.

2.3.4 Hardware Kit

The hardware mounting kit is included. It contains the following:

- Mounting hardware: screws, nuts, and sealing washers



Hole size: 6.4 mm

- Pressure kit: bulkhead fitting, O-ring and tubing inserts, straight connector, sintered element for bulkhead fitting



Panel hole size 29/34 inch (11.5 mm)

2.3.5 Torque Requirements: Control Unit

Hardware	Torque
I.S. and power terminal	0.5–0.6 Nm
Bypass and temperature terminal	0.22–0.25 Nm
Earth ground	7.5 Nm
Main lid	7.5 Nm
Mounting (CU)	7.5 Nm
CG M12	7.5 Nm
CG M20	6 Nm (M20 thread) Cap nut: Single: 18 Nm Double: 22 Nm Triple: 24 Nm
Bulkhead fitting nut	0.5 turn past finger tight*
Compression fitting tube end	1 1/4 turns past finger tight*

* When finger tightening, take care not to overtighten!

2.3.6 Internal-Mounting the Control Unit

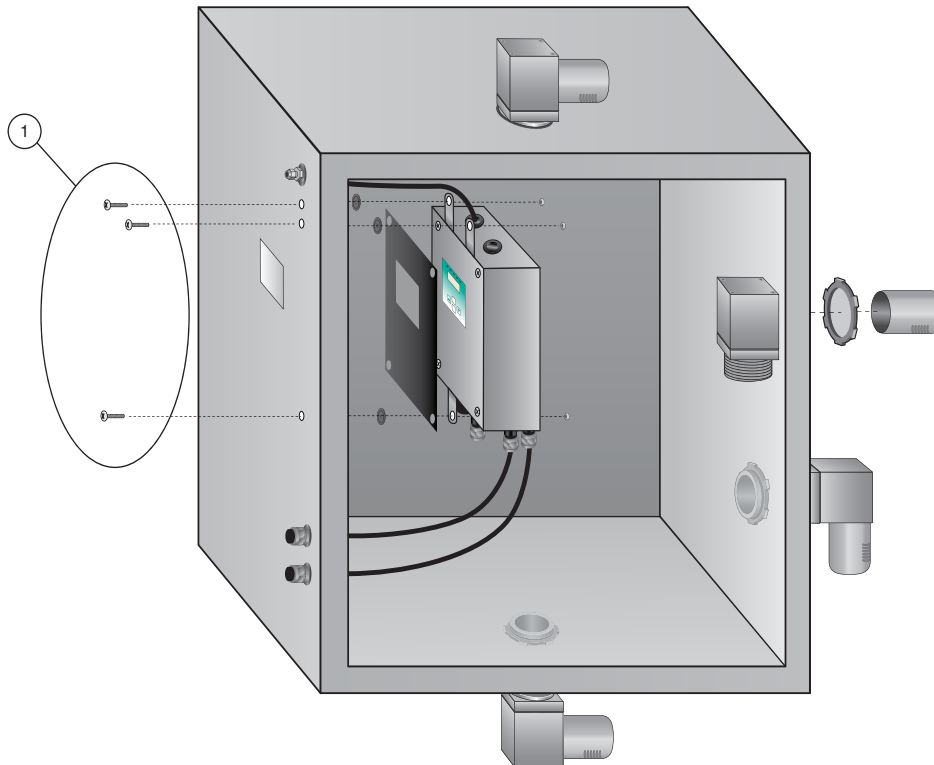

i

Note

1. RTDs are not included.
2. Pressure reference kit is included. Required to measure ambient pressure outside for the differential pressure sensor within the 5500 control unit. Tubing kit connected to port labeled “Atmospheric Pressure”.
3. Keypad must be mounted in a vertical orientation.

2.3.7 External-Mounting the Control Unit

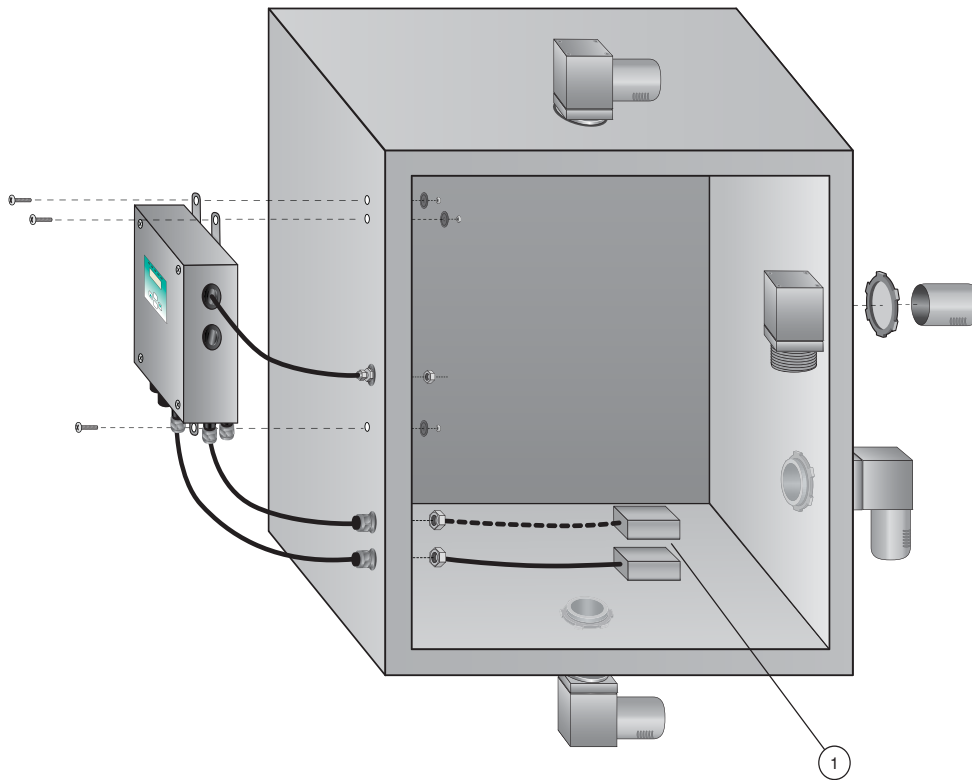

i

Note

1. RTDs are not included.
2. Pressure reference kit is included. Required to measure ambient pressure outside for the differential pressure sensor within the 5500 control unit. Tubing kit connected to port labeled "Enclosure Pressure".
3. Keypad must be mounted in a vertical orientation.

2.4. EPV-5500 Vents

EPV-5500 vents work with the 5500 control unit and manifold to provide a functional, certifiable purge and pressurization system for enclosures. As required by all pressurized enclosure systems, the EPV-5500 vent functions as a pressure relief device and allows the purge gas to exit the enclosure, yet provides a seal when the enclosure is pressurized and operating. The vent also has a spark arrestor, which is required for hazardous areas.



EPV-5500 Components

- EPV-5500 vent with spark arrestor
- Sealing washer and nut for internal or external mounting
- Hex key for removing, attaching, and rotating the vent cap

2.4.1 Technical Data: EPV-5500 Vents

Item	Value
Pneumatic parameters	
Protective gas supply	Compressed air or inert gas, 40 µm filter, free from oil
Maximum pressure	Depends on the integrity of the enclosure (strength)
Purge flow rate	See graphs
Flow rate for leakage compensation	EPV-....-01: approx. 21 scfh (593 l/hr) at 0.63 mbar (0.25 in wc) approx. 58 scfh (1640 l/hr) at 1.9 mbar (0.75 in wc) EPV-....-02: approx. 14 scfh (395 l/hr) at 0.63 mbar (0.25 in wc) approx. 34 scfh (961 l/hr) at 1.9 mbar (0.75 in wc) EPV-....-03: approx. 9.2 scfh (260 l/hr) at 0.63 mbar (0.25 in wc) approx. 22 scfh (622 l/hr) at 1.9 mbar (0.75 in wc)
Breaking pressure	EPV-....-01: 2.0 mbar (0.8 in wc) EPV-....-02: 3.5 mbar (1.4 in wc) EPV-....-03: 3.8 mbar (1.5 in wc)

Ambient conditions	
Ambient temperature	-40 ... 70 °C (-4 ... 140 °F)
Relative humidity	5 ... 95 %, non-condensing
Vibration resistance	5 ... 100 Hz , 1 g, 12 m/s ² , all axes
Impact resistance	30 g, 11 ms, all axes
Mechanical specifications	
Degree of protection	EPV-....-01/02: mounting only Type 4X / IP66 EPV-....-03: Type 4X / IP66
Material	
Housing	EPV-5500-AA...: 6061T6 anodized aluminum (body and cap) EPV-5500-SS...: 6061T6 anodized aluminum (body), 316L stainless steel (cap)
Spark arrestor	316L stainless steel
Installation	<ul style="list-style-type: none"> any orientation to enclosure not gravity dependent
Mass	EPV-....-01/02/03: approx. 1 kg (2.2 lb)
Dimensions	See dimensions in Section 2.3.4.
Mounting	Mounting hole 1 ½" NPT knockout (50.8 mm) Hole-sealing washer and nut (provided)

2.4.2 Flow Rate Curves

The enclosure pressure vs. flow rate curves below represent the EPV-5500....-01, 02, and 03 vents. This corresponds to the enclosure pressure and is independent of the valve used, provided the valve can deliver the flow rate that is required.

The curves below represent completely sealed enclosure, which may not be representative of the customer's enclosure. More flow may be required to reach the enclosure pressure in the enclosure due to leakages from gaskets, seals, windows, etc.

The EPV-5500-...-01 is best suited for large enclosures because it has a higher flow rate and lower back pressure within the enclosure than the other versions. This can reduce the purging time while keeping the enclosure pressure low, which is important for a large enclosure. However, this vent leaks more pressure through its flow control mechanism.

The EPV-5500-...-02 provides a better seal at the vent than the EPV-5500-...-01. The flow rate for purging is less for the same enclosure pressure of the '-01' version.

The EPV-5500-...-03 provides the best seal for pressurization and should be selected for a smaller enclosure, bottled air, or inert gas sources, and for increased conservation of the protective gas source. The flow rate is less than the '-01' and '-02' versions but provides very low leakage.

There is no restriction on the enclosure size for each vent, but leakage rate, flow rate, and enclosure pressure should be considered when applying these vents and the purge time 166 min.

EPV-5500-...-01 Flow Rate Curve

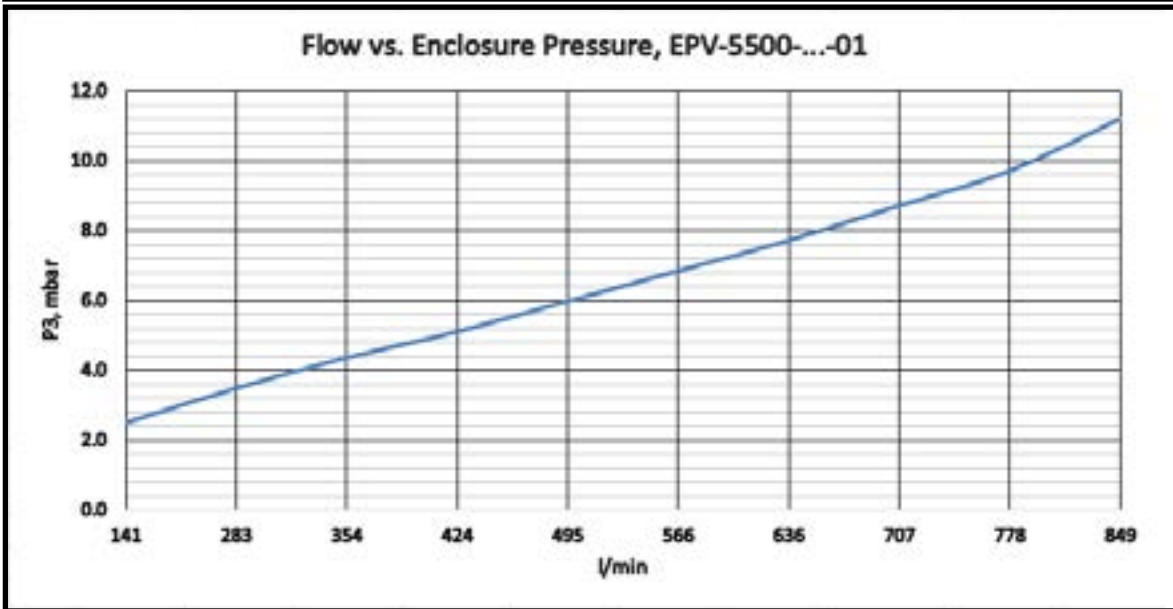
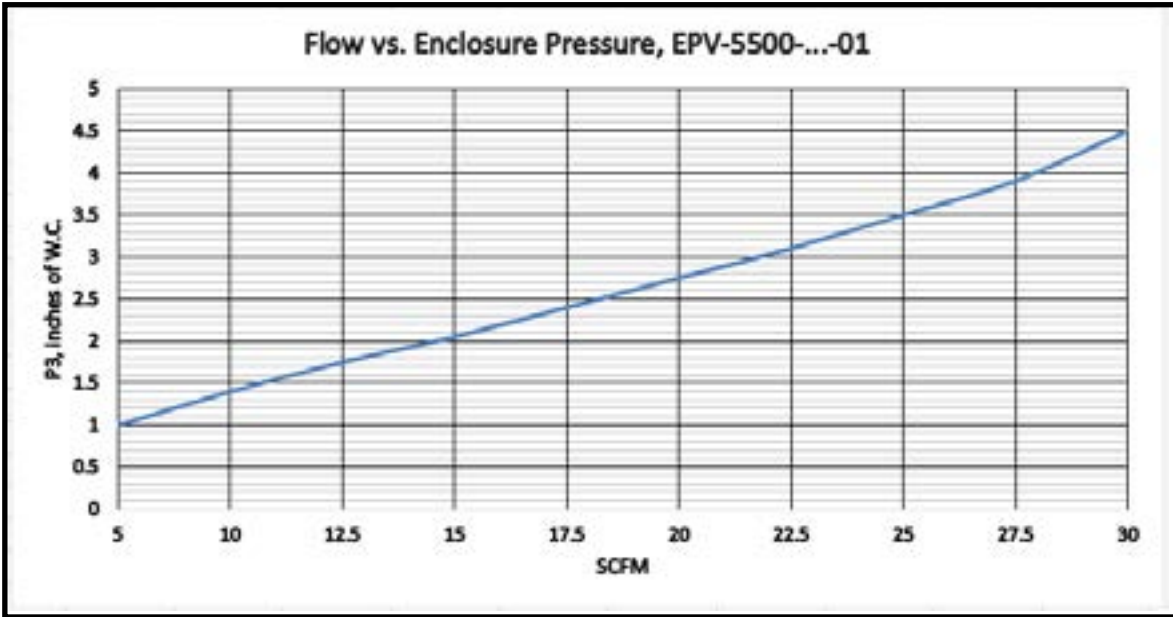

Inches WC	SCFM	mbar	l/min
1	5	2.5	141
1.4	10	3.5	283
1.75	12.5	4.4	354
2.05	15	5.1	424
2.4	17.5	6.0	495
2.75	20	6.8	566
3.1	22.5	7.7	636
3.5	25	8.7	707
3.9	27.5	9.7	778
4.5	30	11.2	849

DOCT-B3R8 • 01/2024

EPV-5500-...-02 Flow Rate Curve

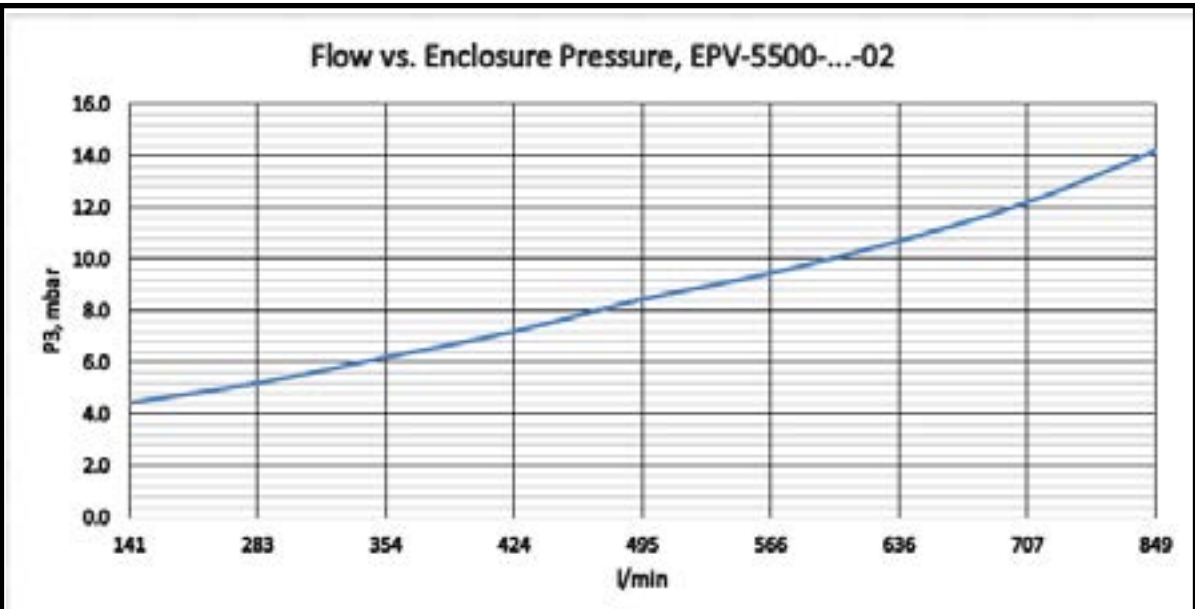
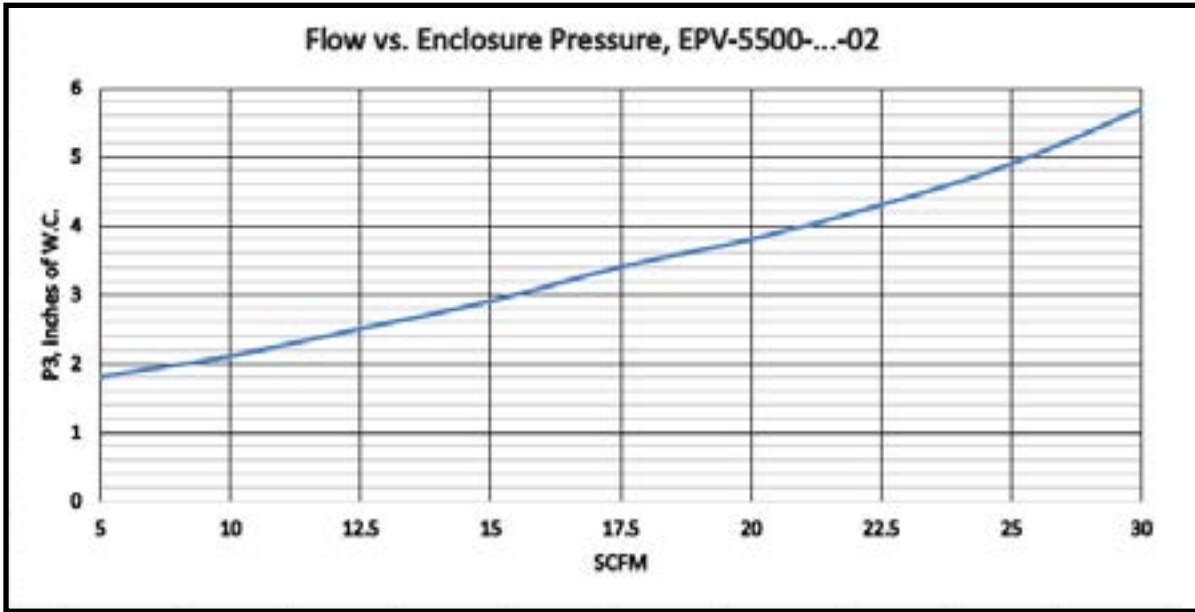

Inches WC	SCFM	mbar	l/min
1.8	5	4.5	141
2.1	10	5.2	283
2.5	12.5	6.2	354
2.9	15	7.2	424
3.4	17.5	8.5	495
3.8	20	9.5	566
4.3	22.5	10.7	636
4.9	25	12.2	707
5.7	30	14.2	849

EPV-5500-...-03 Flow Rate Curve

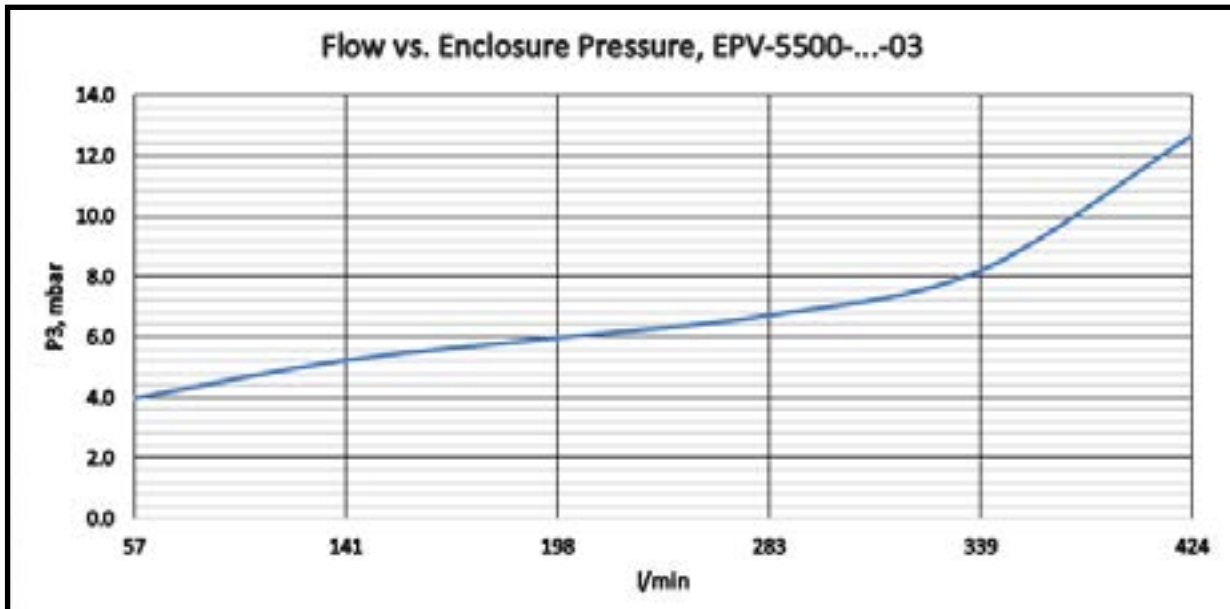
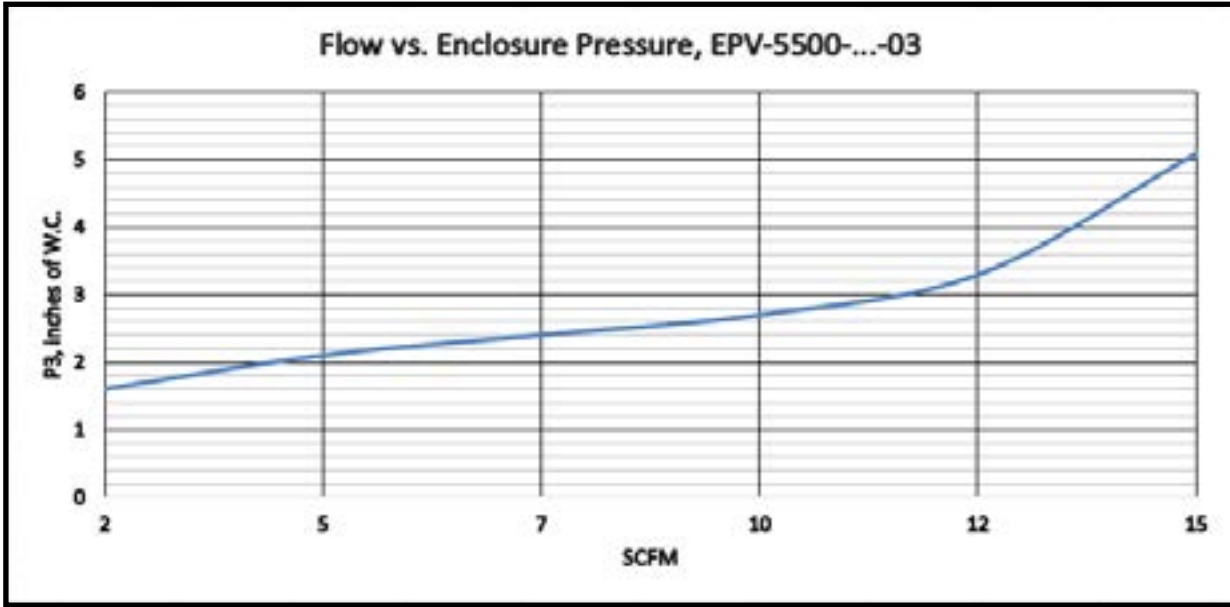

Inches WC	SCFM	mbar	l/min
1.6	2	4.0	57
2.1	5	5.2	141
2.4	7	6.0	198
2.7	10	6.7	283
3.3	12	8.2	339
5.1	15	12.7	424
7.5	20	18.7	566

DOCT-B3R8 • 01/2024

2.4.3 Dimensions: EPV-5500 Vents

EPV-5500-...-01/02/03

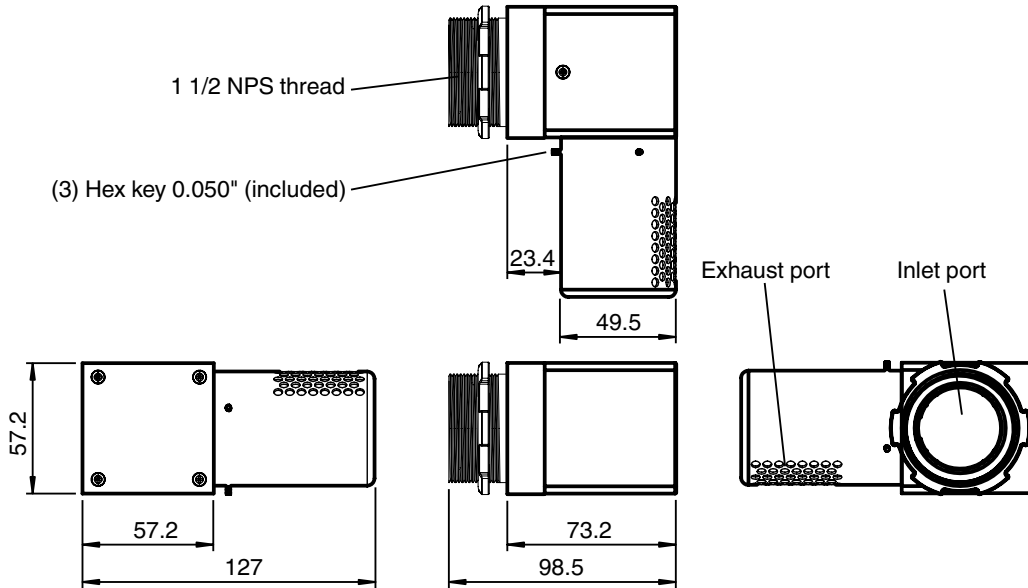

2.4.4 Torque Requirements: EPV-5500 Vents

Hardware	Torque
Sealing washer and nut	0.25–1 turns past finger tight.*
Set screws	Secure vent cap evenly by threading in set screws.

* When finger tightening, take care not to overtighten!

2.5. Manifold Valves

5500-MAN... manifold valves include a solenoid valve for purging and a needle valve for pressurization in one manifold design. When the valve is energized, the solenoid valve is open and allows a high flow rate of protective gas into the enclosure. The amount of flow is controlled by the regulated pressure supply of the protective gas to the manifold. When the valve is de-energized, the flow is through the internal needle valve and is adjustable with the included hex key (for CDUL valve) or slot-head screwdriver (EX01 and CD01 valves). The solenoid valve is used for purging and leakage compensation, with signals from the 5500 control unit that will have these set points defined by the user.

Mounting hardware includes 3/8 inch tube compression fittings mounted on the manifold for input and output flow, 3/8 inch tube compression bulkhead fitting for getting flow into the enclosure, and sealing washers that are certified by UL with bolts to mount the manifold to the enclosure.

Also included is 1 meter of 3/8 inch poly tubing with 3/8 inch poly tube stiffener inserts that allow users to connect plastic tubing to compression fittings without collapsing the tubing. Stainless steel tubing can be used with existing fittings.

For NEC, ATEX, and IECEx applications, see the type code for the correct model. The 5500 valve system works with the 5500 control unit as well as EPV-5500 vents. The 5500 control system is certified by UL for Class/Division installation. Users can also use their own pneumatic system or the 5500-MAN-MV-01 manual manifold. These valves are not part of the evaluation of the certification of the 5500 control unit and EPV-5500... vent.

The 5500 control unit comes with a fuse that is sufficiently sized for the MAN-5500 manifold valve. If the user utilizes a different solenoid, they must pay special attention to the fuse size requirements of that solenoid and change the fuse F1 accordingly. The fuse must be 5x20mm, UL Recognized under JDYX2/8, and may be rated for no higher than 0.08 A for AC and 0.5 A for DC.

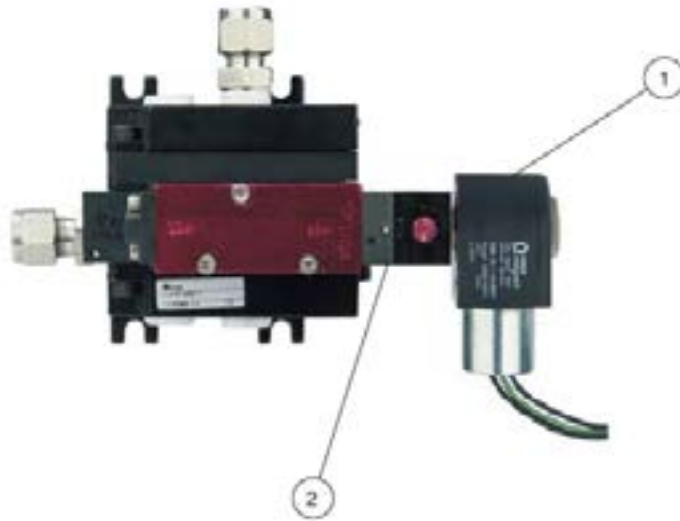

1. Solenoid coil for purging
2. 1/8 inch hex key adjustment for pressurization (included)



Tubing kit (included)



Mounting hardware (included)

5500 manifolds include the solenoid and manual needle valve, as well as the following:

- 3/8 inch compression ferrule fittings for inlet and outlet protective gas source
- 3/8 inch compression ferrule bulkhead fitting that attaches to enclosure—for protective gas to inside enclosure
- 3/8 inch poly tubing (2 m length)
- Inserts for poly tubing to ferrule fitting connection. If stainless steel tubing is used, inserts are not required.
- Hex key for pressurization valve included with 5500-MAN-CDUL version
- Mounting hardware: screws, nuts, and sealing washers



Note

When ordering, note the supply voltage of the 5500 control unit. Order the manifold valves accordingly. Voltages are 24 V DC, 120 V AC, and 220 V AC. 5500 MAN-CDUL manifold valves are only available with 60 Hz operation.

2.5.1 Technical Data: 5500 Manifolds

Property	Value
General specifications	
Operation mode	Compressed air or inert gas, 40 µm filter, free from oil
Series	5500
Hazardous environment	gas or dust
Supply	
Rated power equipment	5500-MAN-CDUL
24 V DC	5.6 W
120 V AC	7.2 VA, 60 Hz
230 V AC	7.2 VA, 60 Hz
Rated power equipment	5500-MAN-CD01
24 V DC	4.6 W
120 V AC	6.8 VA, 60 Hz
230 V AC	6.8 VA, 60 HZ
Rated power equipment	5500-MAN-EX01
24 V DC	2.6 W
120 V AC	3.1 VA, 50 ... 60 Hz
230 V AC	3.0 VA, 50 ... 60 Hz
Voltage tolerance	± 10 %

Fuse rating on 5500 control unit	
DC voltage	500 mA
AC voltage	80 mA
Pneumatic parameters	5500-MAN-CDUL (only 60 Hz for AC version)
Protective gas supply	40 µm filtered air or inert gas
Pressure requirement	25 psi (1.7 bar) to 115 psi (8.0 bar)
Purge flow rate (solenoid valves)	Cv (flow coefficient) = 1.4
Pressurization flow (needle valve)	Cv (flow coefficient) = 0.24
Pneumatic parameters	5500-MAN-CD01
Protective gas supply	40 µm filtered air or inert gas
Pressure requirement	20 psi (1.4 bar) to 120 psi (8.2 bar)
Purge flow rate (solenoid valves)	Cv (flow coefficient) = 1.4
Pressurization flow (needle valve)	Cv (flow coefficient) = 0.24
Pneumatic parameters	5500-MAN-EX01
Protective gas supply	40 µm filtered air or inert gas
Pressure requirement	20 psi (1.4 bar) to 120 psi (8.2 bar)
Purge flow rate (solenoid valves)	Cv (flow coefficient) = 1.4
Pressurization flow (needle valve)	Cv (flow coefficient) = 0.24
Mechanical specifications	
Degree of protection (connector)	Type 7 and 9
Mass	1.25 kg (2.8 lb)
Dimensions	See dimension drawings
Mounting manifold	5500-MAN-CDUL/5500-MAN-EX01/5500-MAN-CD01
Mounting hole	6.75 mm (17/64")
Mounting hardware	Sealing screws, nut, and washer provided
Material	
Housing	Anodized aluminum
3/8 inch compressions fittings	AISI 316L (1.4404) stainless steel
Pressure ports	3/8" NPT
Bulkhead fitting	AISI 316L (1.4404) stainless steel
Mounting bolts	1/4-20, 316 stainless steel
Sealing washers	
Pneumatic connection type	Pneumatic
Input port	3/8 inch tube compression fitting
Output port	3/8 inch tube compression fitting

Electrical connection	
5500-MAN-CD	1/2 inch NPT thread connection with 24 inch (0.61 m)
5500-MAN-EX01	3 m cable



WARNING!

During installation, ensure that no foreign bodies lie inside or can enter the valve. The digital valve must be rated for mounting in a hazardous area.

2.5.2 Dimensions: 5500 Manifolds

5500-MAN-CDUL

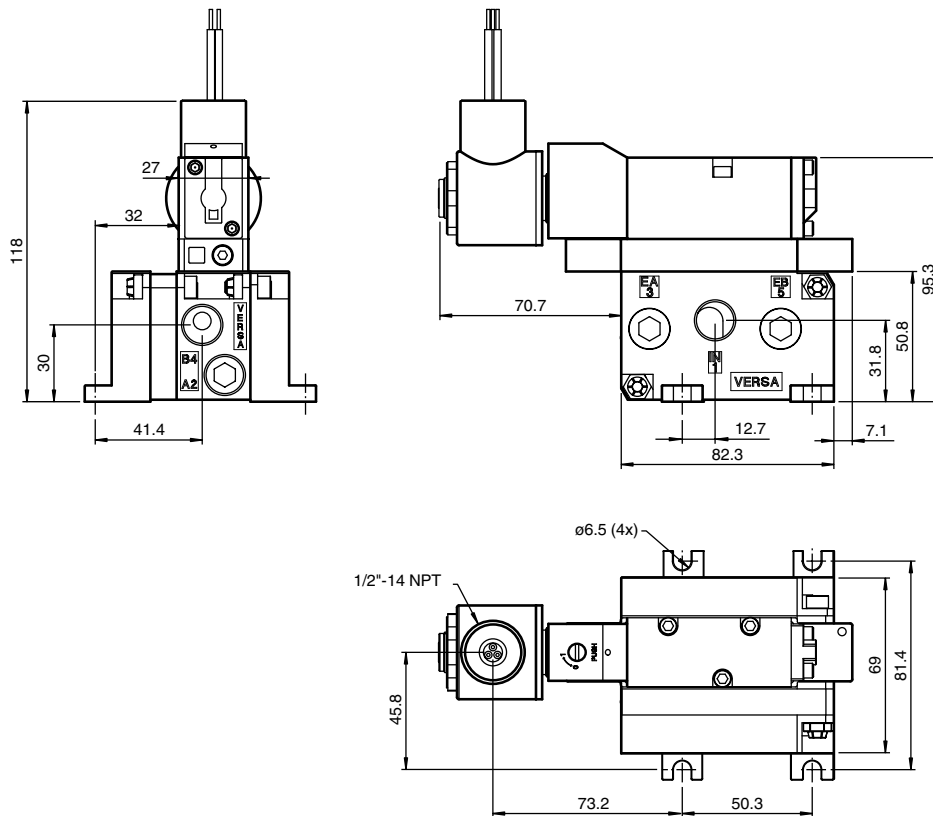

Bulkhead Fitting

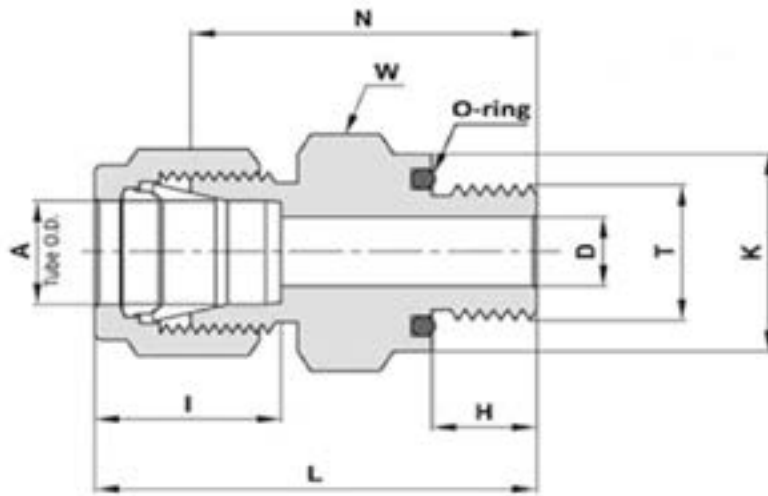

Ordering information	768LO_3/8 x 9/16-18
A (Tube OD)	9.52 mm (3/8 in)
T (Straight thread UNF)	9/16-18 in
D	7.11 mm (0.28 in)
K	23.62 mm (0.93 in)
W (Hex flat)	15/16 in
N	35.05 mm (1.38 in)
H	11.93 mm (0.47 in)
L	40.89 mm (1.67 in)
I	16.8 mm (0.66 in)

5500-MAN-EX01

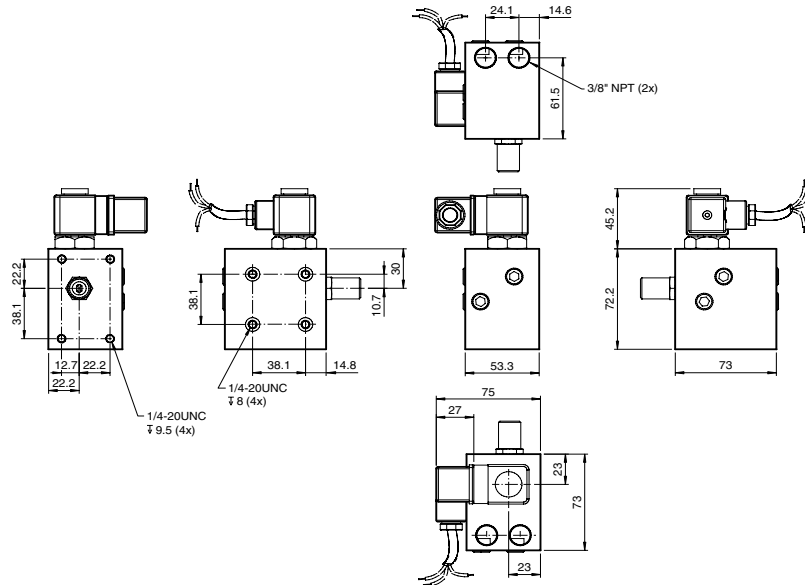

5500-MAN-CD01

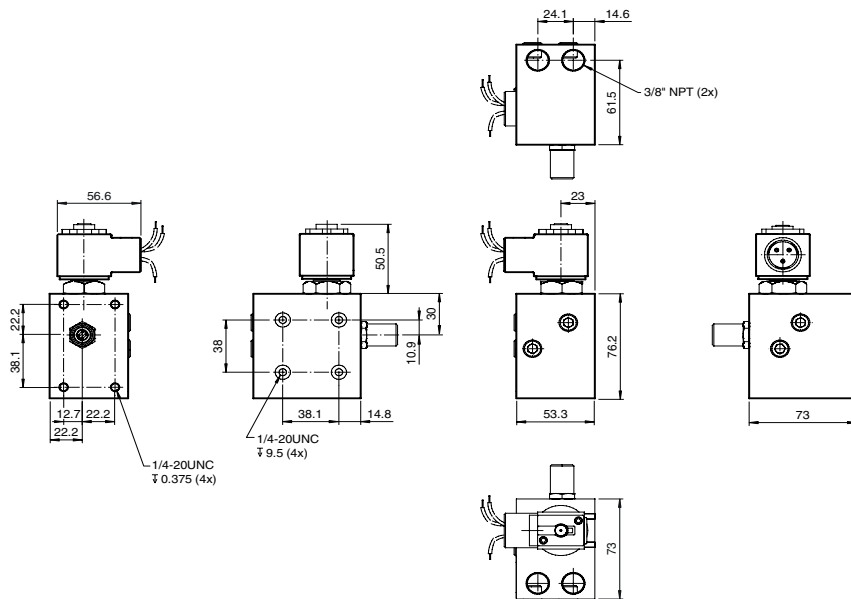

2.5.3 Torque Requirements: Manifolds

Hardware	Torque
Screws, nuts, and sealing washers	8.5 Nm (75.2 in-lb)
Bulkhead fitting nut	40 Nm (350 in-lb)
Compression fitting tube end	1¼ past finger tight
Knurled nut (solenoid)	1.2 Nm (max)
Plastic cable gland (solenoid)	Hand tight
Mounting screw (solenoid)	Secure solenoid with screw. Do not over tighten.

3. Installation and Operation

The 5500 series control unit, vent, and manifold can be universally mounted to the customer enclosure. The control unit can be mounted within the enclosure or outside the enclosure. A rotating display allows mounting at the left, right, top, or bottom of the enclosure. The EPV-5500 vent can be externally or internally mounted with just the cap showing for exhaust or pressure.

The 5500 system is designed to allow an enclosure that is located in Zone 2 or 22, Class I or II, Division 2 hazardous locations to operate safely by first making it safe internally. This is done either by purging out the hazardous gas or manually cleaning out the dust hazard and then pressurizing the enclosure so that the internal pressure prevents the hazardous atmosphere from entering. The 5500 control unit has a differential pressure sensor within the unit that is pneumatically connected to the protective enclosure to provide pressure for evaluation of the enclosure pressure and the flow through the enclosure during purging. If pressure is lost, then power might remain on. An indication by an alarm or display has to notify the operator of the condition. If the pressurized enclosure has been opened or a positive pressure has not been maintained, then purging for hazardous gas or cleaning the enclosure out for dust atmospheres is required. The flow measurement is evaluated by using the pressure in the enclosure and the known measured flow in the graphs through one of the vents selected.

3.1. Installation

3.1.1 For Gas Atmospheres

If the protective enclosure has been opened or has been subjected to the hazardous atmosphere, purging is required to flush out the hazardous gas that may be inside the protective enclosure. A protective gas is introduced into the enclosure so that the pressure builds up and is exhausted through the enclosure. The measurement of flow is achieved by the 5500 control unit pressure sensor measuring enclosure pressure and using that pressure for the flow tables of the vent selected and enclosure size. Each vent has an enclosure pressure vs. flow table for enclosure size that can be used to determine flow rate. This flow rate is used to determine the purge time required to make the protective enclosure safe.

i

Note

The flow rate curves generated for each vent are measured on a completely sealed enclosure with no leakage from the enclosure. In real applications, there will be some leakage from the enclosure, which will depend on the integrity of the seals and door windows, etc. As the enclosure pressure increases, the leakage may also increase. Always plan on more flow from the protective gas to achieve enclosure pressure because of the leakage.

After purging, the flow into the enclosure can be reduced so that just a small flow is used for leakage compensation for pressurization of the enclosure.

3.1.2 For Dust Atmospheres

If the protective enclosure has been opened or has been subjected to the hazardous atmosphere, the enclosure must be manually cleaned of all combustible dust, closed, and pressurized before supplying power to the enclosure. For dust atmospheres, a higher pressure is required for pressurization and is reflected in the pressure range within the 5500 programming setup.

3.1.3 Setting up the System

Instructions

1. Ensure that the system meets all electrical, mechanical, and pneumatic connections before operation. Refer to this manual and standards for explanation of requirements.
2. Apply power to the 5500 Series system.
3. Program the 5500 Series system using the user interface display on the front of the 5500 control unit. See Chapter 4 for programming instructions.



Note

This step is for initial setup of the 5500 system. This procedure can be skipped if the 5500 control unit has been programmed for the application in which it will be used.

4. Make sure the control valve is closed before applying pressure to the system.
5. Use a regulated pressure source to the valve. Set the regulated pressure to 30 psig (2 bar) or lower. Do not exceed the maximum pressure for the valve and tubing used in the setup.
6. The pressure should be below 0.1 in wc (0.25 mbar). Slowly open the needle valve on the control valve system so that the pressure is above P1. If one of the 5500-MAN... manifolds is being used, the solenoid valve will energize for purging above P1.
7. Check the EPV vent to make sure air is coming out of it. If not, check for any obstructions or improper installation.
8. The system is ready to operate.

3.2. Operation

Operating the System

1. Follow the preceding instructions for setting up the system.
2. For Flush Programs 1 through 4 (hazardous gas environments), purging is required.
 - a. Seal the pressurized enclosure.
 - b. Set enclosure pressure to a value above P1.
 - c. When using the 5500-MAN... manifold, the manifold valve is connected to the SV output. When the enclosure pressure is greater than P1, SV energizes the solenoid valve for purging. For manual or other valves, initiate the purging valve.
 - d. Adjust the regulated pressure so that enclosure pressure is above P3 (purging starts).
 - e. For the 5500-MAN manifold, after purging, the needle valve can be re-adjusted to the user's desire, but it must be above the P1 value.
3. For Flush Program 5 (hazardous dust environment), purging is not required.
 - a. The inside of the enclosure must be cleaned of all combustible dust.
 - b. The enclosure is sealed.
 - c. Adjust the enclosure pressure above P1. The minimum for P1 is 0.65 in wc (1.6 mbar) for hazardous dust environments.
4. If enclosure pressure is above P1, power to the enclosure will be energized.
5. If enclosure pressure drops below P1, power must be disconnected. If power is to remain on, an alarm must be initiated and located near an operator.
6. To energize the pressurized enclosure again, repeat the above sequence.



DANGER!

All 5500 pressurization systems require EPV-5500... vents for pressure relief.

4. Programming

4.1. User Interface

To program the control unit, use the membrane pad on the front of the unit.

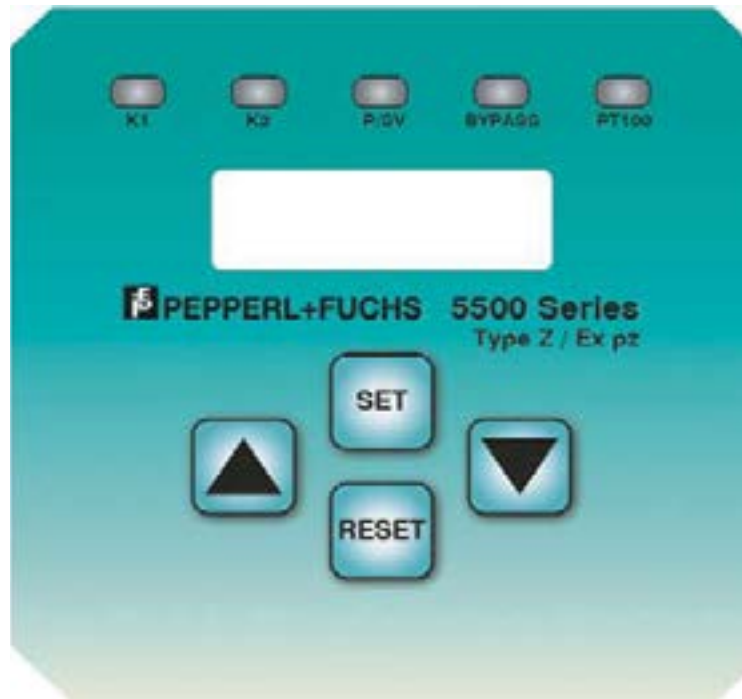





Program settings are saved on non-volatile memory in the CPU. Settings are unaffected by power down and reset function. Default values are stored and can be restored.

4.1.1 LED Indication

	LED Color	Description
K1	Green	Contact K1 is energized
K2	Amber	Contact K2 is energized
P/SV	Blue/amber	Blue: safe pressure Amber: valve on
BYPASS	Amber	Bypass is ON
PT100	Red	PT100 is in fault mode

4.1.2 Buttons

Button	Description
	To advance up
	To advance down
	The set button has three functions: <ol style="list-style-type: none"> 1. Hold for 5 seconds to enter the purge settings 2. Press to advance into the purge setting parameters you have selected 3. Press to enter the purge setting you have selected
	The reset button has two functions: <ol style="list-style-type: none"> 1. When in the purge settings mode, the RESET exits out of the parameter menu 2. When in operation mode, when pressed for 5 seconds, will act like a power interrupt. Any settings programmed will not be lost. The action of the reset happens when the reset button is pressed a second time after the menu shows 'RESET ?' This is NOT a restore to default settings.

4.1.3 Adjusting the Contrast

To adjust the contrast, proceed as follows:

- Hold the UP and DOWN buttons for 3 seconds at the same time. The menu will show the contrast level.
- Adjust the contrast by using the UP and DOWN buttons: The UP button increases the contrast; the DOWN button decreases the contrast.

4.1.4 LCD Backlight

The LCD backlight is always on. It cannot be turned off or adjusted.

4.2. Default Settings

Display	Description	Default Values
PASSWORD / SET	Enter password to access purge settings	0000
PURGE / PROGRAM	Up to 5 programs to select	3
PURGE / TIME	Time required for purging	00:30
ENCLOSUR / PRESS P1	Enclosure pressure P1	Gas: 0.75 mbar (0.3 inch) Dust: 1.75 mbar (0.7 inch)
ENCLOSUR / PRESS P2	Enclosure pressure P2	2.0 mbar (0.8 inch)
ENCLOSUR / PRESS P3	Enclosure pressure P3	7.5 mbar (3.0 inch)
ENCLOSUR / PRESS P4	Enclosure pressure P4	15 mbar (6.0 inch)
LEAKAGE / HYST	Compensates for leakages	1.25 mbar (0.5 inch H ₂ O)
PROGRAM / K2	Various parameters to activate K2 contacts	K1
SHUT-OFF / DELAY	Delay in turning K1 off when P<P1	0 sec
NUMBER / OF PT100	Number of PT100s used	0
TEMP PT1 / SV	SV turns on above PT1	35 °C
TEMP PT2 / SV	SV turns on above PT2	35 °C
TEMP PT1 / K2	K2 turns on above PT1	45 °C
TEMP PT2 / K2	K2 turns on above PT2	45 °C
TEMP PT 1 / K1	K1 turns off above PT1	50 °C
TEMP PT 2 / K1	K1 turns off above PT2	50 °C
BYPASS / N Y E	N for no Y for yes E for external bypass	N
UNITS / M I	M for metric units I for imperial units	I
TEMP / ENABLED	Temperature monitoring on or off	N
CHANGE / PASSWORD	Change existing password	

Restoring Default Settings

To restore default settings, proceed as follows:

- Hold the UP and DOWN buttons at the same time while powering up the control unit.
- Once power to the control unit is on, the default settings will be restored.

The password does not reset to default.

If temperature sensor(s) are connected to the unit, an error will occur for the PT100 because the function is disabled as a default.

4.3. Menu Structure

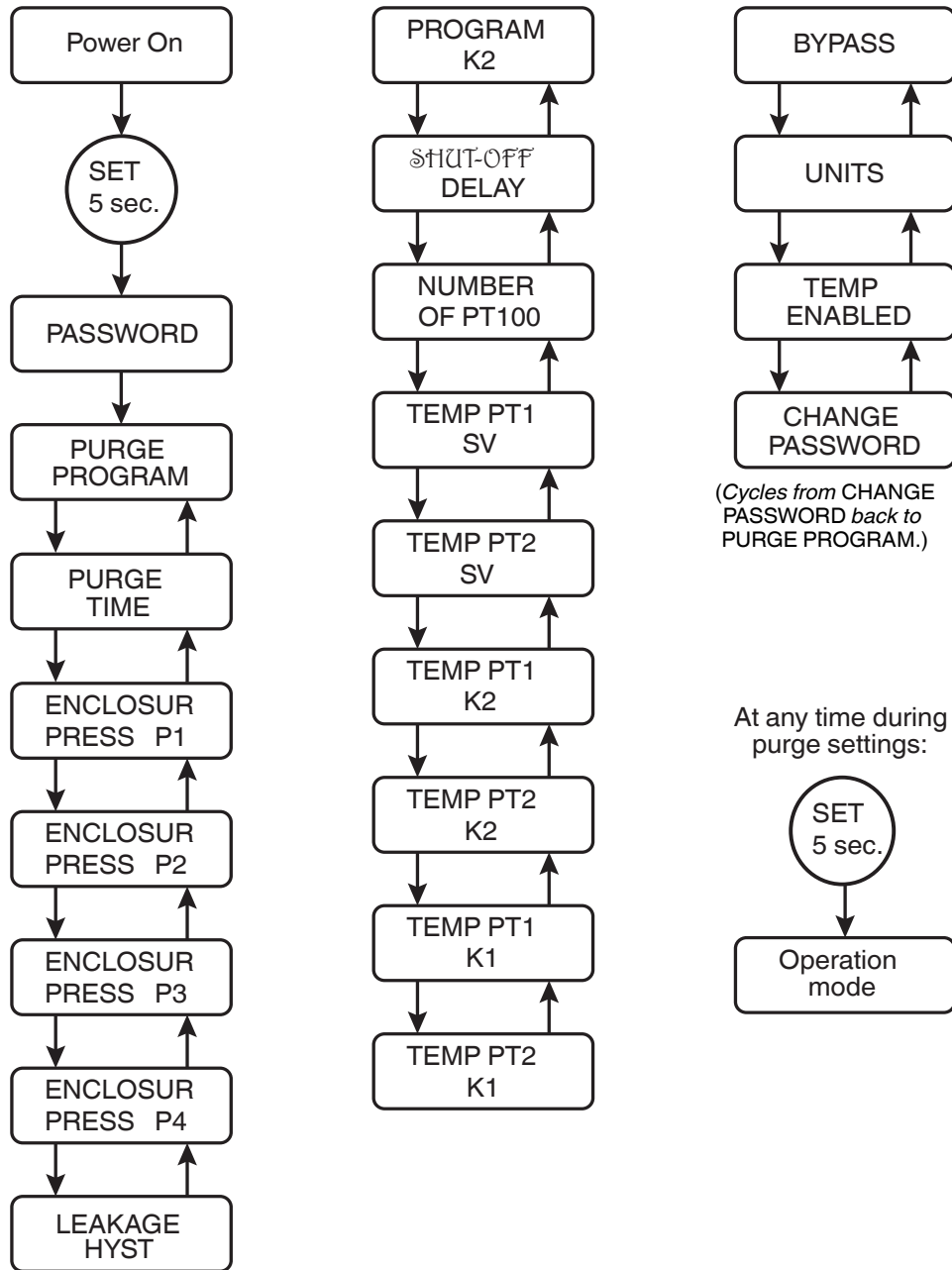

4.4. Purge Programs

There are 5 program selections for system operation. Programs 1 through 4 are for hazardous gas environments and require purging. The fifth program is for hazardous dust environments that require cleaning the enclosure, then pressurizing.

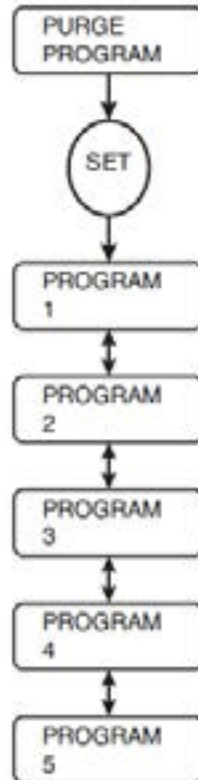

4.4.1 Program 1

Program 1 is used in hazardous gas atmospheres.

Sequence of Events for Program 1

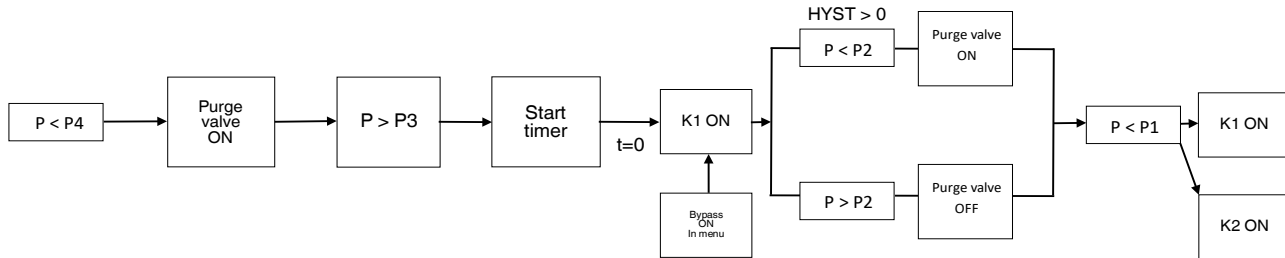

Pre-Purge

- The purge valve (SV) is immediately energized regardless of enclosure pressure.
- If enclosure pressure goes above P4 during purging, SV will shut off but will energize when below P4. Oscillation of SV may be noticed.
- Setting the pressurization valve on the manifold must be done after purging, or the power to SV will have to be interrupted to set this pressure. The solenoid valve on the manifold is immediately energized before this pressure can be set.
- The purge timer begins counting down when the enclosure pressure is greater than P3. Enclosure pressure must remain greater than P3 to purge successfully. If the pressure drops below P3 at any time, or for any length of time, the purge timer is reset and will not begin counting down until pressure is greater than P3

Operation Mode

- After the purge timer counts down, the SV shuts off and K1 is energized.
- If enclosure pressure drops below P2, the SV is energized and will stay energized for the value of HYST (% , leakage compensation). If HYST is set to 0, leakage compensation is turned off.
- If enclosure pressure drops below P1, K1 remains on and an alarm shall be implemented. K2 can be set to P- or Alarm to indicate below safe or operating pressure.
- If enclosure pressure goes above P4, K1 remains. If K2 is set up as Alarm, K2 will energize.



WARNING!

If K1 is used to energize power to the enclosure, K1 will remain energized if pressure is below P1 during system operation. An alarm is required and must be located such that an operator will be notified of the alarm.

4.4.2 Program 2

Program 2 is used in hazardous gas atmospheres.

Sequence of Events for Program 2

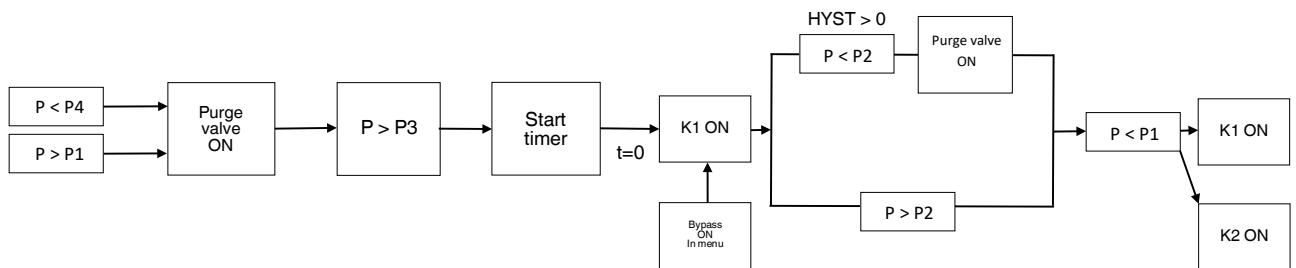

Pre-Purge

- The purge valve (SV) is energized when enclosure pressure is greater than P1.
- If enclosure pressure goes above P4 during purging, the SV shuts off but will energize when below P4. Oscillation of SV may be noticed.
- Setting the pressurization valve on the manifold has to be done after purging, or the power to SV will have to be interrupted to set this pressure. The solenoid valve is energized once enclosure pressure is above P1. Adjusting the pressurization valve before the solenoid valve is energized will allow the enclosure pressure to be above P1 when purging is completed. Fine adjustment of P1 can be achieved after purging when the solenoid valve is off.
- The purge timer begins counting down when enclosure pressure is greater than P3 and must remain greater than P3 to purge successfully. If the pressure drops below P3 at any time, or for any length of time during purging, the purge timer is reset and will not begin counting down until pressure is greater than P3.

Operation Mode

- After the purge timer counts down, the SV shuts off and K1 is energized.
- If enclosure pressure drops below P2, the SV is energized and will stay energized for the value of HYST (% , leakage compensation). If HYST is set to 0, leakage compensation is turned off.
- If enclosure pressure drops below P1, K1 remains on and an alarm shall be implemented. K2 can be set to P- or Alarm to indicate below safe or operating pressure.
- If enclosure pressure goes above P4, K1 remains. If K2 is set up as Alarm, K2 will energize.



WARNING!

If enclosure pressure is below P1 when K1 is used to provide power to the enclosure during operation, K1 will remain energized. An alarm is required and must be located such that an operator will be notified of the alarm.

4.4.3 Program 3

Program 3 is used in hazardous gas atmospheres.

Sequence of Events for Program 3

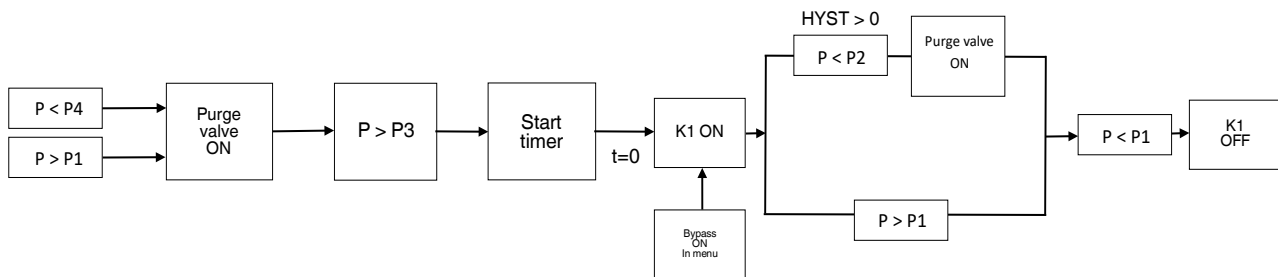

Pre-Purge

- The purge valve (SV) is energized when enclosure pressure is greater than P1.
- If enclosure pressure goes above P4 during purging, the SV will shut off but will energize when below P4. Oscillation of SV may be noticed.
- Setting the pressurization valve on the manifold must be done after purging, or the power to SV will have to be interrupted to set this pressure. The solenoid valve is energized once enclosure pressure is above P1. Adjusting the pressurization valve before the solenoid valve is energized allows the enclosure pressure to be above P1 when purging is completed. Fine adjustment of P1 can be achieved after purging, when the solenoid valve is off.
- The purge timer begins counting down when enclosure pressure is greater than P3, and it has to remain greater than P3 to purge successfully. If the pressure drops below P3 at any time, or for any length of time during purging, the purge timer is reset and will not begin counting down until pressure is greater than P3.

Operation Mode

- After the purge timer counts down, the SV shuts off and K1 is energized.
- If enclosure pressure drops below P2, the SV is energized and will stay energized for the value of HYST (% , leakage compensation). If HYST is set to 0, leakage compensation is turned off.
- If enclosure pressure drops below P1, K1 turns off immediately or after the Shutdown delay timer times out. K1 remains off until the enclosure goes through a successful purging.
- If enclosure pressure goes above P4, K1 remains. If K2 is set up as Alarm, K2 will energize.

4.4.4 Program 4

Program 4 is used in hazardous gas atmospheres.

Sequence of Events for Program 4

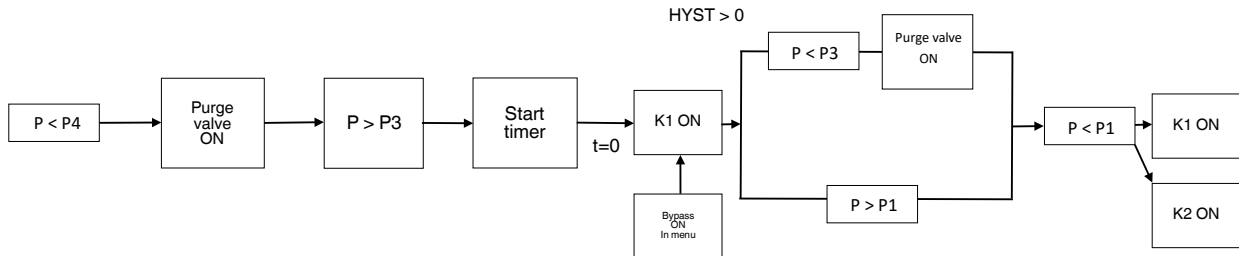

Pre-Purge

- The purge valve (SV) is immediately energized regardless of enclosure pressure.
- If enclosure pressure goes above $P4$ during purging, the SV shuts off but will energize when below $P4$. Oscillation of SV may be noticed.
- Setting the pressurization valve on the manifold has to be done after purging, or power to SV will have to be interrupted to set this pressure. The solenoid valve on the manifold is immediately energized before this pressure can be set.
- The purge timer begins counting down when enclosure pressure is greater than $P3$, and it has to remain greater than $P3$ to purge successfully. If the pressure drops below $P3$ at any time, or for any length of time during purging, the purge timer is reset and will not begin counting down until pressure is greater than $P3$.



WARNING!

If enclosure pressure is below $P1$ when K1 is used to provide power to the enclosure during operation, K1 will remain energized. An alarm is required and must be located such that an operator will be notified of the alarm.

Operation Mode

- After the purge timer counts down, the SV shuts off and K1 is energized.
- If enclosure pressure drops below $P3$, the SV is energized and will stay energized for the value of HYST (% , leakage compensation). If HYST is set to 0, leakage compensation is turned off. However, Program 4 is usually used when a continuous purging through the enclosure is required during operation mode.
- If enclosure pressure drops below $P1$, K1 remains on and an alarm will sound. K2 can be set to P- or Alarm to indicate below safe or operating pressure.
- If enclosure pressure goes above $P4$, K1 remains. If K2 is set up as Alarm, K2 will energize.

4.4.5 Program 5

Program 5 is used in combustible dust atmospheres.

Sequence of Events for Program 5

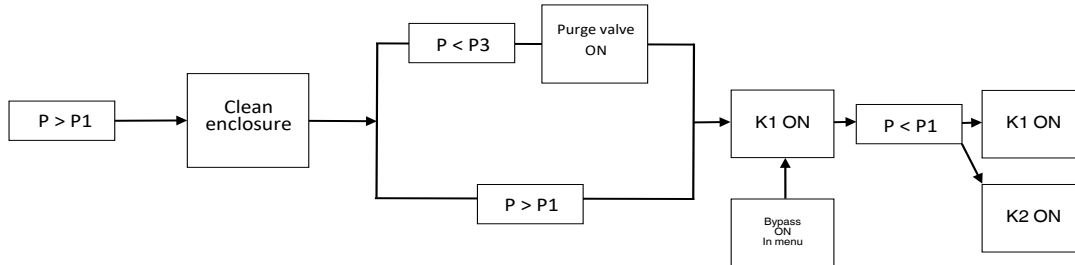

Pre-Purge

- The purge valve (SV) does not come on during this operation. In a dust atmosphere, purging is not required. Instead, the enclosure must be cleaned of all combustible dust and then pressurized.
- The menu screen will show “CLEAN ENCLOSURE.” The enclosure should be cleaned and then pressurized before pressing the SET button.
- The enclosure pressure has to be above P1 (minimum 0.65 in wc / 1.6 mbar for dust atmospheres) for the SET button to work.

Operation Mode

- After cleaning out and pressurizing the enclosure, the menu shows “CLEAN ENCLOSURE.” To see the enclosure pressure, press the Down or Up button. Pressing the SET button will energize K1.
- If enclosure pressure drops below P2, the SV is energized and will stay energized for the value of HYST (% , leakage compensation). If HYST is set to 0, leakage compensation is turned off. Compensation for leakages is allowed in a dust atmosphere because the enclosure is safe at this point.
- If enclosure pressure drops below P1, K1 remains on and an alarm will sound. K2 can be set to P- or Alarm to indicate below safe or operating pressure.
- If enclosure pressure goes above P4, K1 remains. If K2 is set up as Alarm, K2 will energize.



WARNING!

If enclosure pressure is below P1 when K1 is used to provide power to the enclosure during operation, K1 will remain energized. An alarm is required and must be located such that an operator will be notified of the alarm.

Program	1		2		3		4		5	
Purging	K1	SV	K1	SV	K1	SV	K1	SV	K1	SV
P<P1	off	on	off	off	off	off	off	on	off	off
P1<P<P2	off	on	off	on	off	on	off	on	off	off
P2<P<P3	off	on	off	on	off	on	off	on	off	off
P3<P<P4	off	on	off	on	off	on	off	on	off	off
P>P4	off	off	off	off	off	off	off	off	off	off
										Clean activates above P1
After purging										
P<P1	on	on	on	on	off	off	on	off	on	off
P1<P<P2	on	on	on	on	on	on	on	on	on	on
P2<P<P3	on	off	on	off	on	off	on	on	on	off
P3<P<P4	on	off	on	off	on	off	on	off	on	off
P>P4	on	off	on	off	on	off	on	off	on	off



Note

Shutoff delay timer and bypass affect the status of K1 and SV. See the explanation for each to determine effects on K1 and SV.

4.5. Purging Timer

4.5.1 Determining Purge Time

Programming the Purging Timer (MIN:SEC)

1. Calculate the purging time.
2. Enter the purging time using the UP and DOWN buttons and SET.
3. To change the purging time by 1-second increments, press the UP or DOWN button.
4. To make purging time faster, hold down the button continuously. Purging time will advance faster, as the button is held down for longer times (in 5 seconds, 1 min, 5 min increments).

Maximum purge time is 166:39.

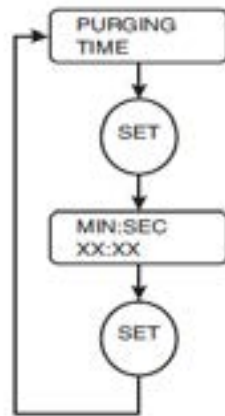

To make sure the enclosure is safe from the hazardous atmosphere, the inside of the enclosure has to be free of the hazardous atmosphere and pressurized before the equipment inside can be powered.

The first step in this process is to get rid of the hazardous atmosphere within the enclosure.

For a dust atmosphere, the inside of the enclosure must be cleaned out and then pressurized. The dust must be cleaned out manually or with a vacuum that is rated for the area. Alternatively, it must be cleaned out in a non-hazardous area.

For gas atmospheres, the enclosure is purged by introducing a flow of protective gas (compressed air, or Inert gas) through the enclosure to make it safe. Depending on the standards that are being used to evaluate the effectiveness of the purging operation, the volume of protective gas through the enclosure determines the amount of time for purging. The exchange of protective gas is related to the volume of the enclosure, the number of exchanges, and the flow rate through the enclosure.

Below is an equation for determining the purging time:

$$\text{(number of volume exchange) x (volume of the enclosure) / flow rate = purging time}$$

The 5500 control unit has a purge timer and is user-selectable through the menu.

The purge timer is activated when the enclosure pressure goes above P3. The pressure must always be above P3 for the timer to continue until it counts down to 000:00. If the enclosure pressure drops below P3 for any amount of time, then the timer is reset to its starting value and will not start counting down until pressure is above P3.

The flow rate for P3 value can be found on the graphs for vent flow in Section 2.4.2. The flow rate for P3 depends on the EPV-5500 vent that is being used.

The more the enclosure leaks pressure, the higher the flow rate into the enclosure required to achieve the P3 threshold.

The number of volume exchange depends on

- the item being purged and
- the standard it is being evaluated to.

Number of exchanges	Class/Division (NFPA 496)	Zone (60079-2)
4	X	n/a
5	n/a	X
10 (motors)	X	X

EXAMPLE	Class/Division (NFPA 496)	Zone (60079-2)
P3=	2.6 inches water	6.5 mbar
Vent=	EPV-5500-...-02 table for P3: EPV-5500-...-02, see Section 2.4.2.	
Enclosure volume=	10 ft ³	282 liters
Flow rate from P3 (see table)	11.3 scfm	320 liters/min
NEC (Class/Division)	4 volume exchange	4 volume exchange
Zone (ATEX, IECEx)	5 volume exchange	5 volume exchange
NFPA:	$4 \times 10 \text{ ft}^3 / 11.3 \text{ scfm} = 3.6 \text{ min}$	$4 \times 282 \text{ liters} / 320 \text{ l/min} = 3.6 \text{ min}$
Zone:	$5 \times 10 \text{ ft}^3 / 11.3 \text{ scfm} = 4.5 \text{ min}$	$5 \times 282 \text{ liters} / 320 \text{ l/min} = 4.5 \text{ min}$
Motors:	$10 \times 10 \text{ ft}^3 / 11.3 \text{ scfm} = 8.9 \text{ min}$	$10 \times 282 \text{ liters} / 320 \text{ l/min} = 8.9 \text{ min}$

4.5.2 Pressure Settings

4.5.2.1 Minimum Enclosure Pressure “P1”

In accordance with the applicable standards and tolerances on the 5500 pressure sensor, the minimum operating pressures are as follows:

- Gas environments: 0.7 mbar (0.25 in wc)
- Dust environments: 1.6 mbar (0.65 in wc)

When enclosure pressure drops below P1 during operation mode, the power has to be interrupted. If not, an alarm has to be generated to address the problem.

4.5.2.2 Alarm Pressure “P2”

If enclosure pressure drops below P2 during operation mode, the solenoid valve will energize until pressure goes above P2+HYST. Therefore, leakage compensation has to be implemented.

If leakage compensation is not used, the P2 can sound an alarm to indicate that pressure is dropping.

P2 can be adjusted to above P1 and below P3 values.

4.5.2.3 Purging Pressure “P3”

The purging timer starts when enclosure pressure is above P3. If the enclosure pressure is above P3, purging will start and finish uninterrupted. If the enclosure pressure is below P3, the purging timer will not start. If the enclosure pressure drops below P3 during purging, the purging timer will immediately reset to its beginning time and will not start timing down until enclosure pressure is above P3. P3 can be adjusted to above P2 and below P4 values.

4.5.2.4 Maximum Internal Pressure “P4”

If enclosure pressure is above P4, the display will read ‘MAX’ to indicate that maximum pressure has been achieved. Regardless of the action of the solenoid valve (purging, leakage compensation), the solenoid valve will de-energize and will not come on until enclosure pressure goes below P4. This action may cause the solenoid valve to oscillate on and off. If this happens, it should be noted as a maximum pressure problem.

If K1 was on before P4 was reached, it will remain on after enclosure pressure is above P4. P4 is adjusted above P3. Maximum setting is 25 mbar (9.99 in wc).

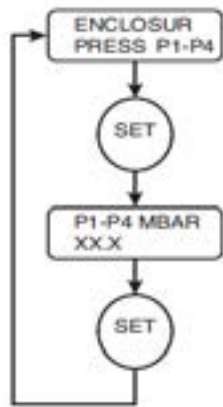

Set values for P1, P2, P3, and P4 using this procedure.

Leakage Compensation Hysteresis “HYST”

In operation mode, there may be excess leakage of pressure from the enclosure due to a faulty seal or gasket. There could also be enclosure pressure loss due to a drop in regulated line pressure. The leakage compensation option allows the SV to turn on to compensate for these unintentional leakages. Depending on the purge program being used, the SV will energize when below P* and will de-energize when is above P* + hysteresis.

P* = P2 when using Program 1, 2, 3, or 5. P* = P3 when using Program 4.



Note

If leakage compensation is not required, set HYST to '0'.

Values for hysteresis HYST

Inches WC	mbar
0	0
0.2	0.5
0.4	1.0
0.6	1.5
0.8	2.0
1.0	2.5
1.2	3.0
1.4	3.5
1.6	4.0
1.8	4.5
2.0	5.0

Example

Units are in mbar, hysteresis = 1.5, then SV is on at P2 and turns off at P2 + 1.5

They HYST unit of measurement is the units being used.

If HYST = 1.5, then this is 1.5 mbar.

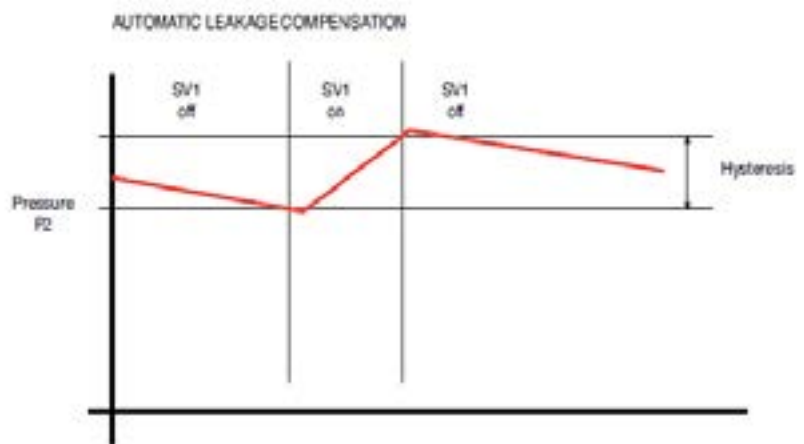
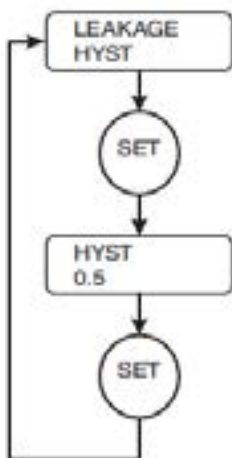

4.5.3 Programming K2

The K2 contact output can be programmed for various settings that are chosen by the user.

For Type Z and Ex pz systems, power to the pressurized enclosure may remain on if pressure goes below the minimum allowed pressure, but an audible and/or visual alarm must be generated to notify the operator of a problem.

K2 can be used to generate the signal for the alarm when properly configured. Alarm function based on any pressure point (P1 to P4 is not available when K2 is mapped to K1, purging or bypass. Additionally, the K2/ALARM LED indication is not an alarm indication when K2 is mapped to these functions.

When K2 is mapped to a function that is not an alarm for loss of safe pressure, the power to the enclosure must be automatically removed, or an external method of alarming is required.

User-Selectable Settings for K2

Setting	Function
K1	Switches simultaneously with K1 ¹
P1+	Switches on when pressure exceeds P1
P1-	Switches on when pressure falls below P1
P2+	Switches on when pressure exceeds P2
P2-	Switches on when pressure falls below P2
P3+	Switches on when pressure exceeds P3
P3-	Switches on when pressure falls below P3
P4+	Switches on when pressure exceeds P4
P4-	Switches on when pressure falls below P4
FT (purging time)	Switches on when purge timer starts and shuts off at the end of purging
Temp AL	Switches on K2, if there is a temp alarm
BYPASS	Switches on when they bypass function is activated
ALARMS	Comes on when P1-, P4, Bypass, Temp AL

1. *This mode is intended for use when the system is controlling a line-to-line power source into the protected enclosure and both power lines need to be switched.

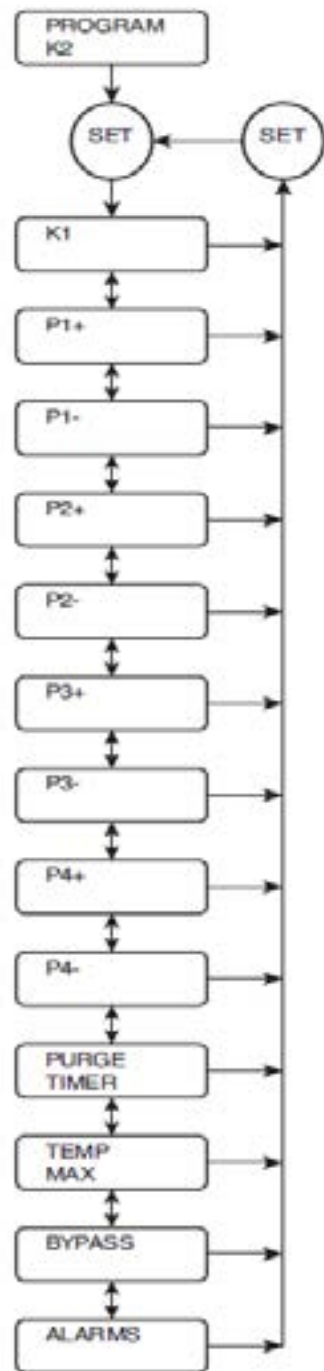

4.6. Shutoff Delay Timer for K1

The shutoff delay timer is used in the operation mode and allows K1 to remain on for the duration of this setting when enclosure pressure drops below the minimum setting of P1. If the pressure goes above P1 during the countdown, the timer is reset. If the pressure remains below P1 for the duration of the countdown, K1 will shut off.

The shutoff delay timer is effective only for Program 3, in which K1 de-energizes when enclosure pressure is below P1. The other programs allow power to the enclosure to remain on when pressure is below P1, with an alarm generated to the operator.

The default value is 0 seconds. The range is 0 to 300 seconds.

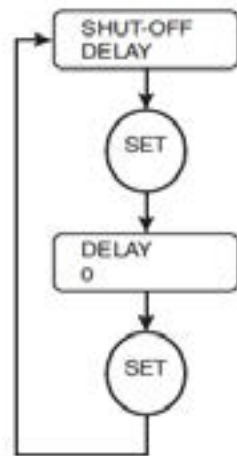

4.7. Number of PT100 Temperature Sensors Used

The 5500 control unit allows up to two 2-wire PT100s to be connected to the unit for monitoring and controlling temperatures in the pressurized enclosure.

Each sensor can be located up to 3 m from the control unit input. Using two PT100s allows various placements within the enclosure to capture the variation of heat in locations where electronic devices are located.

In order for the temperature inputs to work, Number of PT100s and Temperature enabled must be activated. An incorrect number of PT100s selected will give a error on the PT100 input, the PT100 LED will light up, and TEMP AL will be activated if selected for K2.

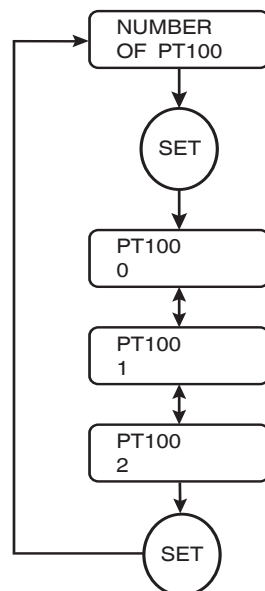

4.8. Temperature Inputs PT1 and PT2

To Activate this Function

1. Enter the number of PT100s into the menu with the correct number of sensors connected to the input.
2. Select ENABLED in the TEMP ENABLED selection menu.
3. All values are entered in degrees Celcius. (Fahrenheit is not available.)

TEMP PT1 SV, TEMP PT2 SV

When the temperature on the PT100(s) is greater than the user set value, the SV contact is energized. The manifold will be energized and the purge flow will begin to flush out the cabinet to allow for cooling. The SV contact remains energized until temperature falls to 3 °C below this set temperature.

TEMP PT1 K2, TEMP PT2 K2

If the temperature within the enclosure continues to increase because the SV valve is not efficient enough to cool, this second trip point can be used to activate K2 when K2 is programmed for TEMP AL (temperature alarm). This can be used to control a secondary cooling device or as a warning. K2 (TEMP ALARM) contact remains energized until temperature falls to 3 °C below this set temperature.

TEMP PT1 K1, TEMP PT2 K1

If the temperature rises above this set point. K1 will de-energize and the LCD will display OVER TMP, indicating over temperature. A RESET must be done to get the system to operate again. The RESET will work only when the temperature goes below the user-set temperature value. Depending on the program used, the RESET will cause the system to re-purge or CLEAN out the enclosure.



Note

If TEMP ENABLE is off, the number of PT100s is '0', and a PT100 is connected to one of both of the inputs, the PT100 LED will turn on. This is to indicate that there is something not correct with the temperature setup of this system. The system will still operate, but the LED will remain illuminated until the issue is corrected.

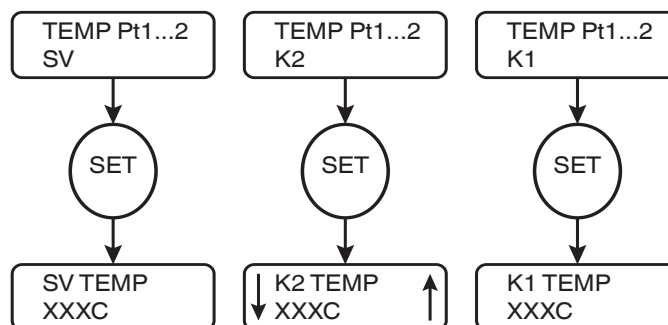

AUTOMATIC TEMPERATURE CONTROL

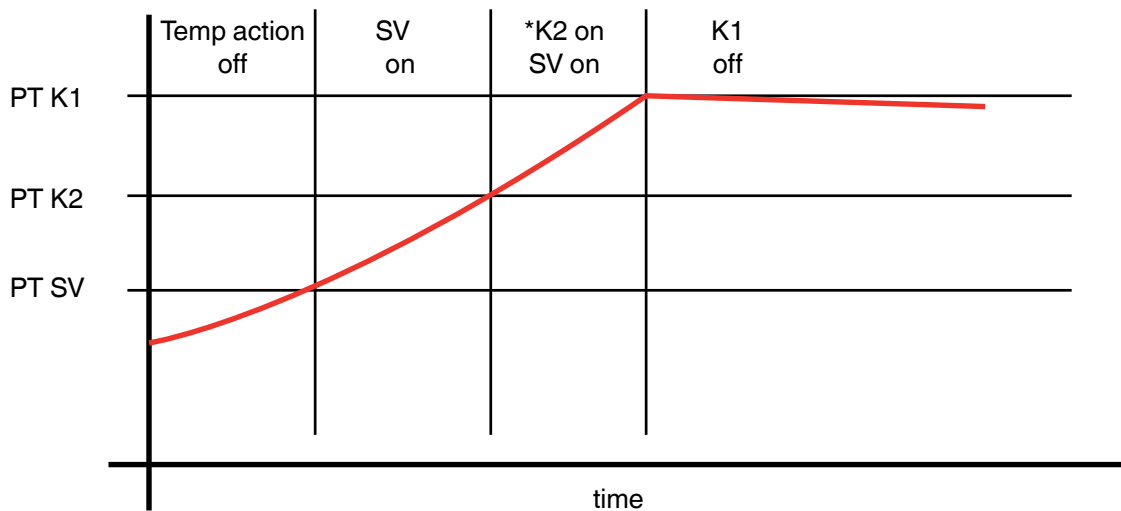

* Note: K2 is mapped to Any Alarm or Temp Max. For above action to take place.

4.9. Bypass

The Bypass mode allows power to the enclosure to be energized when the enclosure pressure is below the minimum pressure P1. This can be useful in commissioning the enclosure or working on the enclosure when it is open.

The Bypass option has three modes of operation to choose from.

Mode		Description
N	No	Bypass is not enabled.
Y	Yes	Bypass is implemented using the purge settings menu. By selecting 'Y', the system will go into bypass and will turn on K1. In the 'Y' mode, K1 will be energized before the system goes through a successful purge. This mode can be useful in commissioning the enclosure during start up. This mode is on when it is selected and the menu stays in the purge settings mode. If the user exits from the purge settings mode, then the 'Y' is automatically changed to 'N' and K1 will de-energize. Bypass LED is on while bypass is active.
E	External	The bypass is implemented using the HW input on the control unit and is only operational when the enclosure is safe and pressure is above P1. The 'E' mode will not energize K1 if the enclosure is not safe. Bypass LED is on.



DANGER!

Bypass should only be implemented when the area surrounding the pressurized enclosure is known to be non-hazardous.

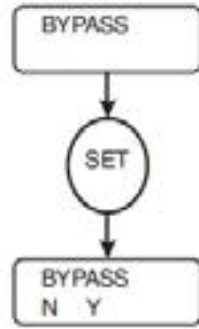

4.10. Units

The units can be changed from 'M' metric to 'I' imperial. This affects the pressure readings. "M" reads in mbar, and "I" reads in inches of water column. The temperature settings are always in Celsius.

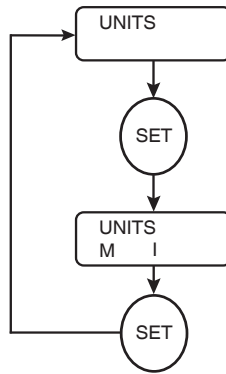

4.11. Temp Enabled

TEMP ENABLED allows for temperature alarm/control when ON. TEMP ENABLED and NUMBER OF PT100 has to be selected for temperature alarm/control to be effective. If one is selected and another is not, a PT100 LED fault LED will be on

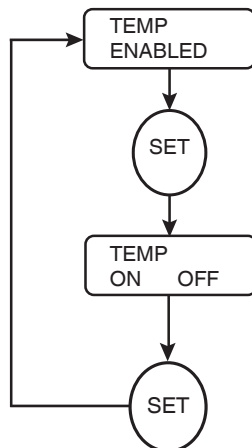

4.12. Change Password

To change the existing password, use the UP and DOWN buttons for each digit.

Enter 4 digits.

To cancel without saving a new password, press RESET. The existing password will still be valid.



Note

There is no confirmation of key strokes when changing the password. Note what the new password is when changing it.

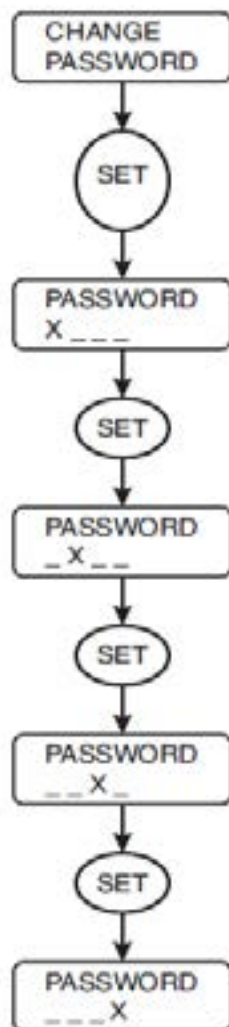

4.13. User Parameter Setting Sheet

Display	Description	User Settings
PASSWORD / SET	Password	
PURGE / PROGRAM	Program 1-5	
PURGE / TIME	Time required for purging	
ENCLOSUR / PRESS P1	Shutdown pressure P1	
ENCLOSUR / PRESS P2	Alarm/signal pressure P2	
ENCLOSUR / PRESS P3	Purge pressure P3	
ENCLOSUR / PRESS P4	Maximum pressure P4	
LEAKAGE / HYST	Leakage comp and hysteresis compensation	
PROGRAM / K2	User-configured K2 program	
SHUT-OFF / DELAY	Shutoff delay timer for K1	
NUMBER / OF PT	Number of PT100s being used	
TEMP PT1 / SV	SV turns on above PT1	
TEMP PT2 / SV	SV turns on above PT2	
TEMP PT1 / K2	K2 turns on above PT1	
TEMP PT2 / K2	K2 turns on above PT2	
TEMP PT1 / K1	K1 turns on above PT1	
TEMP PT2 / K1	K2 turns on above PT2	
BYPASS / N Y E	Bypass	
UNITS / M I	M for metric units I for imperial units	
TEMP / ENABLED	Temperature monitoring: ON / OFF	

5. Product Identification

5.1. Specific Conditions of Use

- The main control unit and the EPV vent are the only parts that have been evaluated for the certifications of the system.
- For dust environments, the non-metallic membrane touchpad and display may pose an electrostatic discharge hazard. Use only water damp cloth and allow to air dry for cleaning device. Do not use or install in high charge areas. See IEC 60079-32-1 for further information.
- When mounting the 5500 purge control unit, the unit shall not have the membrane keypad exposed to direct UV light sources and direct sunlight. Example methods of protection include, but are not limited to, indoor applications away from UV sources and outdoor locations under shading. As part of regular inspections, if damage to or deterioration of the membrane keypad is detected, the unit is to be taken out of service for repair or replacement.
- When the 5500 purge system is mounted to an enclosure, the complete installation shall be evaluated to the appropriate standards and regulations applicable for the final installation location.
- The purge control unit has a temperature class (T6 or T4) that is dependent on ambient temperature. This temperature shall be considered when mounted to, or inside of, an enclosure.
- All un-used entry points to the 5500 control unit shall be closed with a properly certified ATEX device suitable for the area of installation with the necessary ingress protection.
- The bypass function shall only be enabled during setup or maintenance and only when the area is known to be non-hazardous.
- The device shall be installed in an area of not more than pollution degree 2 as defined in EN 60664-1.
- The device must be installed in accordance with the manufacturer's installation drawing number 116-B026.

5.2. Applied Standards and Markings



Note

See the certificates and/or the Declaration of Conformity for details on specific editions of the standards listed below.

IECEx and ATEX:

EN / IEC 60079-0
 EN / IEC 60079-2
 EN / IEC 60079-7
 EN / IEC 60079-11
 EN / IEC 60079-15
 EN / IEC 60079-31

Purge control for use in hazardous (classified) areas, in accordance with

NFPA 496
 UL/CSA 121201
 CSA C22.2 No. 213
 UL/CSA 61010-1

5.3. Type Codes

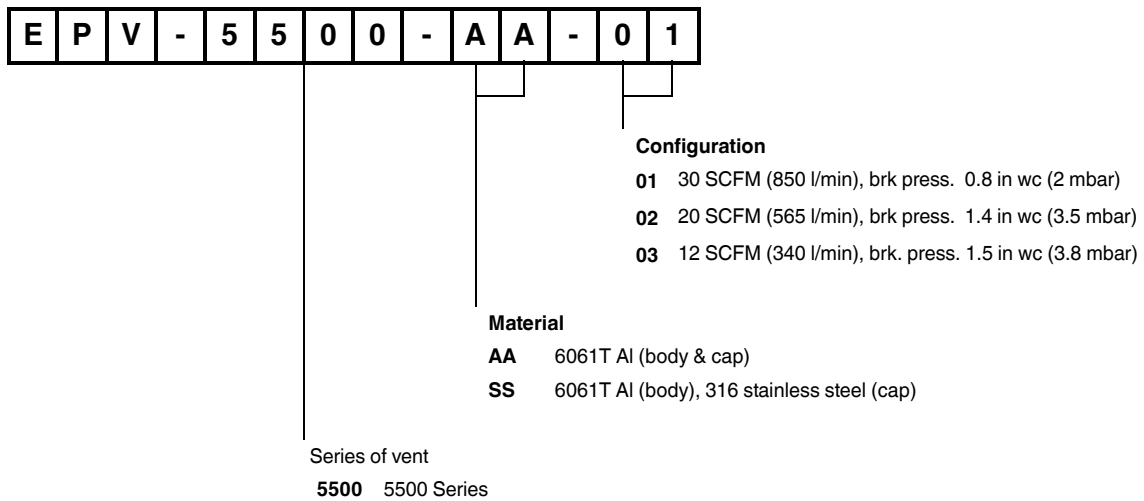
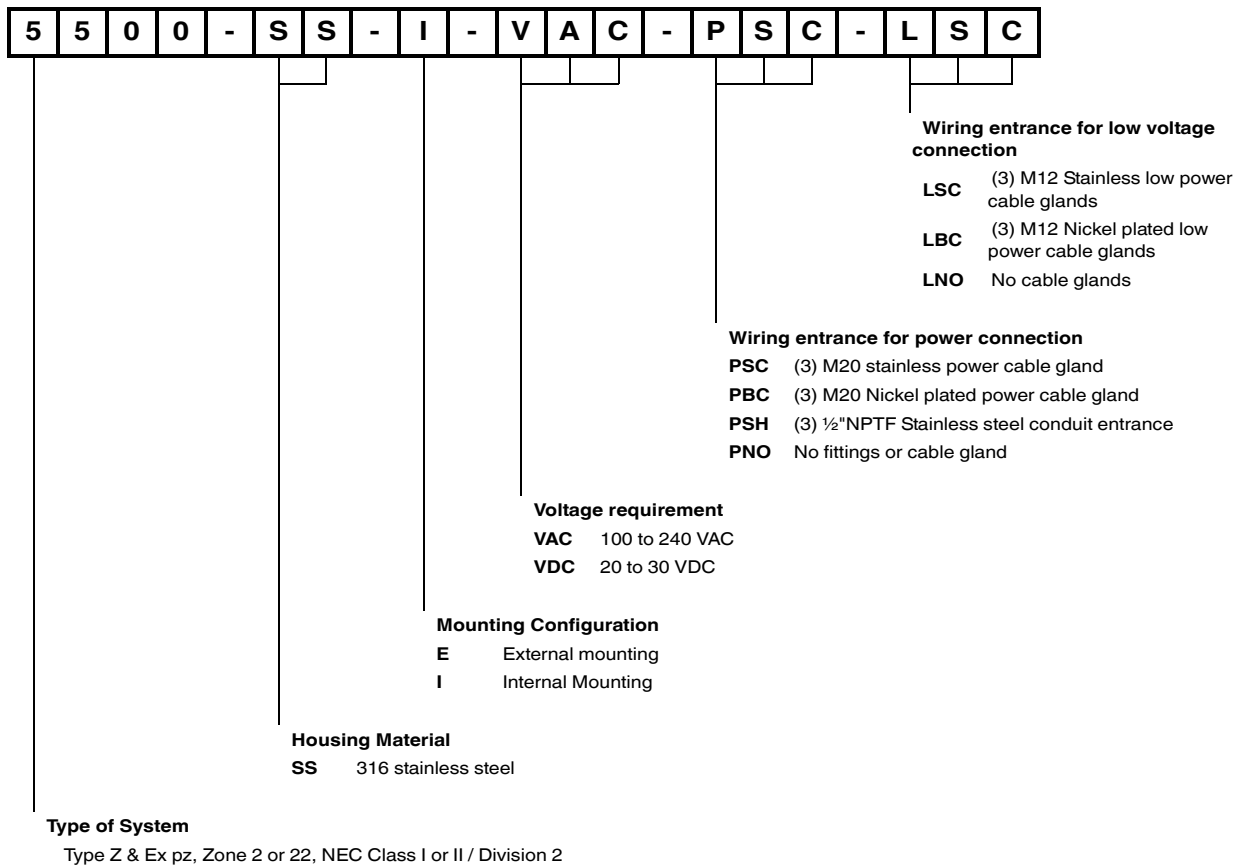

5 5 0 0 - M A N - E X 0 1 - 2 4 V D C

Voltage Requirement

24VDC
120VAC
230VAC

Type of Approval

EX01 ATEX and IECEx certification
CD01 FM and CSA certification
CDUL UL and CSA certification (different body design),
only 60 Hz for AC models

Valve Type

MAN Manifold (includes purging and pressurization valves)

Type of System

Type Z & Ex pz, Zone 2 & 22, NEC Class I & II / Division 2

5.4. Markings (Labelling)

Control Unit, Internal Mount (AC)

PEPPERL+FUCHS
68307 Mannheim, Germany / www.pepperl-fuchs.com

Model 5500-SS-I-VAC-xxx-xxx
Type Z / Ex pzcz PN: 51xxxx

 **Type 4X IP66**  **4 000 00x**
UL file E184741 **xxxxxxx**

4S11

Class I, Division 2, Groups A, B, C, D T4 (-20°C ≤ Ta ≤ 60°C)
Class I, Division 2, Groups A, B, C, D T6 (-20°C ≤ Ta ≤ 40°C)
Class II, Division 2, Groups F, G T4 (-20°C ≤ Ta ≤ 60°C)
Class II, Division 2, Groups F, G T6 (-20°C ≤ Ta ≤ 40°C)

II 3G DEMKO 14ATEX1282X
II 3D IECEX UL 14.0019 X

Ex ic ec nC [ic Gc] [pzc Gc] IIC T4 Gc (-20°C ≤ Ta ≤ 60°C)
Ex ic ec nC [ic Gc] [pzc Gc] IIC T6 Gc (-20°C ≤ Ta ≤ 40°C)
Ex ic tc [ic Dc] [pzc Dc] IIIB T80°C Dc (-20°C ≤ Ta ≤ 60°C)
Ex ic tc [ic Dc] [pzc Dc] IIIC T60°C Dc (-20°C ≤ Ta ≤ 40°C)

TÜV 15.0793 X  

PURGE CONTROL FOR USE IN HAZARDOUS LOCATIONS IN ACCORDANCE WITH THE NATIONAL FIRE PROTECTION ASSOCIATION STANDARD FOR PURGED AND PRESSURIZED ENCLOSURES FOR ELECTRICAL EQUIPMENT NFPA 496-2013.

Power Requirement, CAT II:
100 to 240V_~ / 0.05A / 50-60 Hz 
F1 = 0.08A F2 = 2.0 A
K1: 6A@250V_~ resistive load, 6A@30V 
K2: 3A@250V_~ resistive load, 3A@30V 

WARNING - EXPLOSION HAZARD - DO NOT DISCONNECT WHILE CIRCUIT IS LIVE UNLESS AREA IS KNOWN TO BE NON-HAZARDOUS
WARNING - EXPLOSION HAZARD - SUBSTITUTION OF COMPONENTS MAY IMPAIR SUITABILITY FOR CLASS I, DIVISION 2
WARNING - POTENTIAL ELECTROSTATIC CHARGING HAZARD - SEE INSTRUCTIONS

AVERTISSEMENT - RISQUE D'EXPLOSION NE PAS DEBRANCHER TANT QUE LE CIRCUIT EST SOUS TENSION A MOINS QU'IL NE S'AGISSE D'UN EMPLACEMENT NON DANGEREUX
AVERTISSEMENT - RISQUE D'EXPLOSION - LA SUBSTITUTION DE COMPOSANTS PEUT RENDRE CE MATERIEL INACCEPTABLE POUR LES EMPLACEMENTS DE CLASSE I, DIVISION 2
AVERTISSEMENT - POTENTIEL ELECTROSTATIQUE CHARGE DANGER VOIR LES INSTRUCTIONS

See 116-B026 for Installation information including non-incendive connections.
MADE IN USA -20°C ≤ Ta ≤ 60°C BEBCO EPS®

Control Unit, External Mount (AC)

PEPPERL+FUCHS
68307 Mannheim, Germany / www.pepperl-fuchs.com

Model 5500-SS-E-VAC-xxx-xxx
Type Z / Ex pzcz PN: 51xxxx

 **Type 4X IP66**  **4 000 00x**
UL file E184741 **xxxxxxx**

4S11

Class I, Division 2, Groups A, B, C, D T4 (-20°C ≤ Ta ≤ 60°C)
Class I, Division 2, Groups A, B, C, D T6 (-20°C ≤ Ta ≤ 40°C)
Class II, Division 2, Groups F, G T4 (-20°C ≤ Ta ≤ 60°C)
Class II, Division 2, Groups F, G T6 (-20°C ≤ Ta ≤ 40°C)



II 3G DEMKO 14ATEX1282X
II 3D IECEX UL 14.0019 X

Ex ic ec nC [ic Gc] [pzc Gc] IIC T4 Gc (-20°C ≤ Ta ≤ 60°C)
Ex ic ec nC [ic Gc] [pzc Gc] IIC T6 Gc (-20°C ≤ Ta ≤ 40°C)
Ex ic tc [ic IIC Dc] [pzc Dc] IIIB T80°C Dc (-20°C ≤ Ta ≤ 60°C)
Ex ic tc [ic IIC Dc] [pzc Dc] IIIB T60°C Dc (-20°C ≤ Ta ≤ 40°C)

TÜV 15.0793 X  

PURGE CONTROL FOR USE IN HAZARDOUS LOCATIONS IN ACCORDANCE WITH THE NATIONAL FIRE PROTECTION ASSOCIATION STANDARD FOR PURGED AND PRESSURIZED ENCLOSURES FOR ELECTRICAL EQUIPMENT NFPA 496-2013.

Power Requirement, CAT II:
100 to 240V_~ / 0.05A / 50-60 Hz 
F1 = 0.08A F2 = 2.0 A
K1: 6A@250V_~ resistive load, 6A@30V 
K2: 3A@250V_~ resistive load, 3A@30V 

WARNING - EXPLOSION HAZARD - DO NOT DISCONNECT WHILE CIRCUIT IS LIVE UNLESS AREA IS KNOWN TO BE NON-HAZARDOUS
WARNING - EXPLOSION HAZARD - SUBSTITUTION OF COMPONENTS MAY IMPAIR SUITABILITY FOR CLASS I, DIVISION 2
WARNING - POTENTIAL ELECTROSTATIC CHARGING HAZARD - SEE INSTRUCTIONS

AVERTISSEMENT - RISQUE D'EXPLOSION NE PAS DEBRANCHER TANT QUE LE CIRCUIT EST SOUS TENSION A MOINS QU'IL NE S'AGISSE D'UN EMPLACEMENT NON DANGEREUX
AVERTISSEMENT - RISQUE D'EXPLOSION - LA SUBSTITUTION DE COMPOSANTS PEUT RENDRE CE MATERIEL INACCEPTABLE POUR LES EMPLACEMENTS DE CLASSE I, DIVISION 2
AVERTISSEMENT - POTENTIEL ELECTROSTATIQUE CHARGE DANGER VOIR LES INSTRUCTIONS

See 116-B026 for Installation information including non-incendive connections.
MADE IN USA -20°C ≤ Ta ≤ 60°C BEBCO EPS®

DOCTB3V4 • 01/2024

Control Unit, Internal Mount (DC)

PEPPERL+FUCHS
68307 Mannheim, Germany / www.pepperl-fuchs.com

Model 5500-SS-I-VDC-xxx-xxx
Type Z / Ex pzc PN: 51xxxx

 **Type 4X IP66**  **4 000 00x**
UL file E184741 xxxxxxxx
4S11

Class I, Division 2, Groups A, B, C, D T4 (-20°C ≤ Ta ≤ 60°C)
Class I, Division 2, Groups A, B, C, D T6 (-20°C ≤ Ta ≤ 40°C)
Class II, Division 2, Groups F, G T4 (-20°C ≤ Ta ≤ 60°C)
Class II, Division 2, Groups F, G T6 (-20°C ≤ Ta ≤ 40°C)

II 3G DEMKO 14ATEX1282X
II 3D IECEX UL 14.0019 X

Ex ic ec nC [ic Gc] [pzc Gc] IIC T4 Gc (-20°C ≤ Ta ≤ 60°C)
Ex ic ec nC [ic Gc] [pzc Gc] IIC T6 Gc (-20°C ≤ Ta ≤ 40°C)
Ex ic tc [ic Dc] [pzc Dc] IIIC T80°C Dc (-20°C ≤ Ta ≤ 60°C)
Ex ic tc [ic Dc] [pzc Dc] IIIC T60°C Dc (-20°C ≤ Ta ≤ 40°C)

TÜV 15.0793 X  

**PURGE CONTROL FOR USE IN HAZARDOUS LOCATIONS
IN ACCORDANCE WITH THE NATIONAL FIRE PROTECTION
ASSOCIATION STANDARD FOR PURGED AND PRESSURIZED
ENCLOSURES FOR ELECTRICAL EQUIPMENT NFPA 496-2013.**

Power Requirement, CAT II:
20 to 30V  / 0.2A
F1 = 0.50A F2 = 3.15 A 
K1: 6A@250V  resistive load, 6A@30V 
K2: 3A@250V  resistive load, 3A@30V 

WARNING - EXPLOSION HAZARD - DO NOT DISCONNECT WHILE CIRCUIT IS LIVE
UNLESS AREA IS KNOWN TO BE NON-HAZARDOUS
WARNING - EXPLOSION HAZARD - SUBSTITUTION OF COMPONENTS MAY IMPAIR
SUITABILITY FOR CLASS I, DIVISION 2
WARNING - POTENTIAL ELECTROSTATIC CHARGING HAZARD - SEE
INSTRUCTIONS
AVERTISSEMENT - RISQUE D'EXPLOSION NE PAS DEBRANCHER TANT QUE LE
CIRCUIT EST SOUS TENSION A MOINS QU'IL NE S'AGISSE D'UN EMPLACEMENT
NON DANGEREUX
AVERTISSEMENT - RISQUE D'EXPLOSION - LA SUBSTITUTION DE COMPOSANTS
PEUT RENDRE CE MATERIEL INACCEPTABLE POUR LES EMPLACEMENTS DE
CLASSE I, DIVISION 2
AVERTISSEMENT - POTENTIEL ELECTROSTATIQUE CHARGE DANGER
VOIR LES INSTRUCTIONS

See 116-B026 for Installation information including non-incendive connections.
MADE IN USA -20°C ≤ Ta ≤ 60°C BEBCO EPS®

Control Unit, External Mount (DC)

PEPPERL+FUCHS
68307 Mannheim, Germany / www.pepperl-fuchs.com

Model 5500-SS-E-VDC-xxx-xxx
Type Z / Ex pzc PN: 51xxxx



 **Type 4X IP66**  **4 000 00x**
UL file E184741 xxxxxxxx
4S11

Class I, Division 2, Groups A, B, C, D T4 (-20°C ≤ Ta ≤ 60°C)
Class I, Division 2, Groups A, B, C, D T6 (-20°C ≤ Ta ≤ 40°C)
Class II, Division 2, Groups F, G T4 (-20°C ≤ Ta ≤ 60°C)
Class II, Division 2, Groups F, G T6 (-20°C ≤ Ta ≤ 40°C)



II 3G DEMKO 14ATEX1282X
II 3D IECEX UL 14.0019 X

Ex ic ec nC [ic Gc] [pzc Gc] IIC T4 Gc (-20°C ≤ Ta ≤ 60°C)
Ex ic ec nC [ic Gc] [pzc Gc] IIC T6 Gc (-20°C ≤ Ta ≤ 40°C)
Ex ic tc [ic IIC Dc] [pzc Dc] IIIB T80°C Dc (-20°C ≤ Ta ≤ 60°C)
Ex ic tc [ic IIC Dc] [pzc Dc] IIIB T60°C Dc (-20°C ≤ Ta ≤ 40°C)

TÜV 15.0793 X  

**PURGE CONTROL FOR USE IN HAZARDOUS LOCATIONS
IN ACCORDANCE WITH THE NATIONAL FIRE PROTECTION
ASSOCIATION STANDARD FOR PURGED AND PRESSURIZED
ENCLOSURES FOR ELECTRICAL EQUIPMENT NFPA 496-2013.**

Power Requirement, CAT II:
20 to 30V  / 0.2 A
F1 = 0.50A F2 = 3.15 A 
K1: 6A@250V  resistive load, 6A@30V 
K2: 3A@250V  resistive load, 3A@30V 



WARNING - EXPLOSION HAZARD - DO NOT DISCONNECT WHILE CIRCUIT IS LIVE
UNLESS AREA IS KNOWN TO BE NON-HAZARDOUS
WARNING - EXPLOSION HAZARD - SUBSTITUTION OF COMPONENTS MAY IMPAIR
SUITABILITY FOR CLASS I, DIVISION 2
WARNING - POTENTIAL ELECTROSTATIC CHARGING HAZARD - SEE
INSTRUCTIONS
AVERTISSEMENT - RISQUE D'EXPLOSION NE PAS DEBRANCHER TANT QUE LE
CIRCUIT EST SOUS TENSION A MOINS QU'IL NE S'AGISSE D'UN EMPLACEMENT
NON DANGEREUX
AVERTISSEMENT - RISQUE D'EXPLOSION - LA SUBSTITUTION DE COMPOSANTS
PEUT RENDRE CE MATERIEL INACCEPTABLE POUR LES EMPLACEMENTS DE
CLASSE I, DIVISION 2
AVERTISSEMENT - POTENTIEL ELECTROSTATIQUE CHARGE DANGER
VOIR LES INSTRUCTIONS

See 116-B026 for Installation information including non-incendive connections.
MADE IN USA -20°C ≤ Ta ≤ 60°C BEBCO EPS®

EPV-5500 Vent

PEPPERL+FUCHS
68307 Mannheim, Germany / www.pepperl-fuchs.com

Model EPV-5500-AA-03
Type Z / Ex pz PN: 515664

  
CLASSIFIED
cULus E184741
4S11

Part of DEMKO 14ATEX1282X
Part of IECEX UL 14.0019X
Part of TÜV 15.0793 X

**This device is part of UL Classified
apparatus Type 5500 Purge System**

MADE IN USA -40°C ≤ Ta ≤ 70°C BEBCO EPS®

6. Product Lifetime Care

6.1. Maintenance and Repair

The only special maintenance required on the 5500 system is cleaning of the pneumatic filters on the overall installation, when used, and periodic function checks. This includes pressure readings within the specifications contained in this manual. When checking pressure measurements of the 5500 control unit, use calibrated equipment to determine the measurements, or contact a Pepperl+Fuchs representative or the factory to send the device back for function verification.



WARNING!

No portions of the 5500 system are user-servicable.



WARNING!

When operating the 5500 system in conjunction with a hazardous area, do not modify the system. If there is a defect, the product may need to be replaced. Repairs can only be performed by a Pepperl+Fuchs specialist who is trained and authorized to repair the defect.



WARNING!

When servicing, installing, and commissioning, the area must be free of all combustible material and/or hazardous explosive gas. Only the terminal compartment of the control unit is accessible to users. Under no circumstances shall the control unit or vent be dismantled or removed from the supplied enclosure, unless instructed in this manual.

Contact Pepperl+Fuchs customer service for an RMA (Return Merchandise Authorization).

6.2. Dismantling and Decommissioning

Abide by all local and any other code requirements for disposing of electronic equipment.

When disposing of any component of the 5500 system, VOID must be marked across all certification labels.

6.3. Troubleshooting

Problem	Possible Cause	Solution
Purge cycle does not start	No air to system	Check air supply, make sure minimum pressure is available
	Enclosure pressure not high enough	Check vent and enclosure seals; check compensation valve setting
	Control unit in dust mode	Program 5 was used instead of one of the Programs 1-4. Select proper program.
Memory error	Memory corruption	Power down and power back up. If a memory error exists, the unit is defective.

Your automation, our passion.

Explosion Protection

- Intrinsic Safety Barriers
- Signal Conditioners
- FieldConnex® Fieldbus
- Remote I/O Systems
- Electrical Ex Equipment
- Purge and Pressurization
- Industrial HMI
- Mobile Computing and Communications
- HART Interface Solutions
- Surge Protection
- Wireless Solutions
- Level Measurement

Industrial Sensors

- Proximity Sensors
- Photoelectric Sensors
- Industrial Vision
- Ultrasonic Sensors
- Rotary Encoders
- Positioning Systems
- Inclination and Acceleration Sensors
- Fieldbus Modules
- AS-Interface
- Identification Systems
- Displays and Signal Processing
- Connectivity

Pepperl+Fuchs Quality
Download our latest policy here:

www.pepperl-fuchs.com/quality

