

7500 Purge System User Manual

Bebco EPS® 7500 Series Type Z and
Ex pzc Purge and Pressurization System



Your automation, our passion.

 **PEPPERL+FUCHS**

With regard to the supply of products, the current issue of the following document is applicable:
The General Terms of Delivery for Products and Services of the Electrical Industry, published by the
Central Association of the Electrical Industry (Zentralverband Elektrotechnik und Elektroindustrie
(ZVEI) e.V.) in its most recent version as well as the supplementary clause: “Expanded reservation of
proprietorship”.

Worldwide

Pepperl+Fuchs Group
Lilienthalstr. 200
68307 Mannheim
Germany

Phone: +49 621 776 - 0
E-mail: info@de.pepperl-fuchs.com

North American Headquarters

Pepperl+Fuchs Inc.
1600 Enterprise Parkway
Twinsburg, Ohio 44087
USA

Phone: +1 330 425-3555
E-mail: sales@us.pepperl-fuchs.com

Asia Headquarters

Pepperl+Fuchs Pte. Ltd.
P+F Building
18 Ayer Rajah Crescent
Singapore 139942

Phone: +65 6779-9091
E-mail: sales@sg.pepperl-fuchs.com
<https://www.pepperl-fuchs.com>

Table of contents

1. Introduction.....	6
1.1. Content of this Document	6
1.2. Target Group, Personnel.....	7
1.3. Symbols Used.....	7
1.4. Pertinent Laws, Standards, Directives, and Further Documentation.....	9
1.5. Declaration of Conformity.....	9
2. Product Description	10
2.1. Introduction.....	10
2.2. 7500 System Overview	10
2.3. Control Unit.....	10
2.3.1 Technical Data: Control Unit	11
2.3.2 Terminal Connection Data	14
2.3.3 Wiring Requirements and Electrical Connections.....	14
2.3.4 Dimensions: Control Units	16
2.3.5 Panel Cut-Out Dimensions	16
2.3.6 Pressure Kit.....	17
2.3.7 Torque Requirements: Control Unit.....	17
2.3.8 Dimensions: 7500-MTD-* Mount Systems	18
2.3.9 External/Panel Mounting Illustration	22
2.4. EPV-7500 Vents	23
2.4.1 Technical Data: EPV-7500 Vents	23
2.4.2 Flow Rate Curves	25
2.4.3 Dimensions: EPV-7500 Vents	28
2.4.4 Torque Requirements: EPV-7500 Vents.....	28
2.5. 7500-MAN-MV-01 Manual Manifold.....	29
2.5.1 Technical Data: 7500-MAN-MV-01	29
2.5.2 Dimensions: 7500-MAN-MV-01.....	30
2.5.3 Torque Requirements: 7500-MAN-MV-01	30
2.6. Automatic Manifolds	31
2.6.2 Components: 5500 Manifolds.....	32
2.6.1 Technical Data: 5500 Manifolds (Automatic)	33
2.6.3 Dimensions: 5500 Manifolds	36

2.6.4 Torque Requirements: 5500 Manifolds 37

2.6.5 Technical Data: 7500 Manifolds (Automatic) 38

2.6.6 Components: 7500 Manifolds..... 39

2.6.8 Dimensions: 7500 Manifolds 39

2.6.7 Torque Requirements: 7500 Manifolds 39

3. Installation and Operation 40

3.1. For Gas Atmospheres 40

3.2. For Dust Atmospheres 41

3.3. For Gas and Dust Atmospheres 41

3.4. Setting up the System 41

3.5. Operating the System 42

4. Programming 43

4.1. Touchscreen Display 43

4.1.1 Contrast and Back Light 43

4.1.2 LED Indication 44

4.2. Default Settings..... 44

4.3. Menu Structure 45

4.4. Purge Programming Setting 46

4.4.1 Program 1..... 47

4.4.2 Program 2..... 48

4.4.3 Program 3..... 49

4.4.4 Program 4..... 50

4.4.5 Program 5..... 51

4.5. Purging Timer..... 53

4.5.1 Determining Purge Time..... 53

4.5.2 Pressure Settings 54

4.5.2.1 Minimum Enclosure Pressure “P1” 55

4.5.2.2 Alarm Pressure “P2”..... 55

4.5.2.3 Purging Pressure “P3”..... 55

4.5.2.4 Maximum Internal Pressure “P4” 55

4.5.3 Programming K2 57

4.6. Shutdown Timer for K1..... 59

4.7. Bypass.....	59
4.8. Units.....	60
4.9. Change Password.....	61
4.10. User Parameter Setting Sheet	62
5. Product Identification	63
5.1. Specific Conditions of Use	63
5.2. Applied Standards	63
5.3. Type Codes	64
5.4. Markings (Labelling)	66
6. Product Lifetime Care	68
6.1. Maintenance and Repair	68

1. Introduction

1.1. Content of this Document

This document contains information required to meet the safety and protection requirements for systems with explosion protection in equipment Group II Zones 2 or 22, Class I or II, Division 2 when installing, commissioning, and using the 7500 control unit and its components. This important information will help you use the 7500 purge and pressurization system safely and correctly.

This may include information on the following:

- Product identification
- Delivery, transport, and storage
- Mounting and installation
- Maintenance and repair
- Disposal

Knowledge of the basic safety regulations and additional training and experience in the area of explosion protection are essential for the safe handling and failure-free operation of the 7500 series purge and pressurization system.

These operating instructions contain important data and information to ensure the safe use of the 7500 system in hazardous areas and to meet the requirements of Directive 2014/34/EU. This manual, particularly the safety information, must be followed by all personnel who work on the system.



WARNING!

Failure to follow these instructions may impair the safety protection and function of the equipment.



Note

For complete information on this product, see further documentation at www.pepperl-fuchs.com.

Information about individual components can be provided on request.

The documentation comprises the following parts:

- This document
- Safety instruction manual
- Datasheet

In addition, the documentation may comprise the following parts, if applicable:

- Manufacturer declaration of conformity
- EU declaration of conformity
- Additional documents

1.2. Target Group, Personnel

Responsibility for planning, assembly, commissioning, operation, maintenance, and dismounting of the 7500 series lies with the plant operator. Personnel working on this system must:

- be familiar with the occupational safety and accident prevention regulations and have been briefed regarding handling of the unit.
- have the additional knowledge of explosion protection that is required for work on explosion-protected components.
- be familiar with the relevant rules and regulations for the installation, operation, and maintenance of explosion-protected systems.
- have read the safety section and warnings in this manual.

The operator and/or installer must also ensure that:

- the system is installed in accordance with the Specific Conditions of Use
- that the 7500 system is used as a purge controller and not protected by purging and pressurization
- all electrical, mechanical, and pneumatic connections have been made in accordance with this manual and any other applicable standards and laws.

1.3. Symbols Used

This document contains symbols to identify warning messages and information messages.

Warnings

You will always find warning messages whenever hazards could result from your actions. It is essential that you observe these warning messages to ensure your personal safety and to prevent property damage.

Warning messages are shown in descending order according to the risk level, as follows:



DANGER!

This symbol warns you of an immediate and present danger.

If you do not observe this warning message, there is a risk of personal injury and even death.



WARNING!

This symbol warns you of a potential fault or hazard.

If you do not observe this warning message, there is a risk of personal injury or severe property damage.



CAUTION!

This symbol warns you of a potential fault.

Failure to observe this warning message may result in the malfunctioning or complete failure of the product or any systems and plants connected to it.

Information Messages



Note

This symbol draws your attention to important information.



Action instructions

This symbol highlights an action. You are prompted to perform an action or sequence of actions.

1.4. Pertinent Laws, Standards, Directives, and Further Documentation

NEC, CEC, and other national and local laws, standards, or Directives that are applicable to the intended use and installation location must be observed. In relation to hazardous areas, Directive 1999/92/EC must be observed.

The corresponding datasheets, EU Declaration of Conformity, EU Type Examination Certificates, NEC/NFPA and CEC certificates, and control drawings, if applicable (see datasheet), are an integral part of this document. You can find this information at www.pepperl-fuchs.com.

Due to constant revisions, documentation is always subject to change. Please refer only to the most up-to-date version, which can be found at www.pepperl-fuchs.com.

1.5. Declaration of Conformity

All products were developed and manufactured under observance of the applicable European standards and guidelines.



Note

A Declaration of Conformity is included with these instructions and can be requested from the manufacturer or obtained online at www.pepperl-fuchs.com. Additional documentation can also be provided for individual components.

The product manufacturer, the Pepperl+Fuchs Group, 68307 Mannheim, has a certified quality assurance system that conforms to ISO 9001.



ISO9001

2. Product Description

2.1. Introduction

Purge and pressurization is one of the most versatile ignition protection classes. Purge and pressurization systems are based on the principle that in Zone 2/Class I Division 2 (gas), the gas mixture in the ambient atmosphere, which may ignite under certain circumstances, is removed from the housing by an initial purge process. After the purge phase, sufficiently compressed inert gas, usually air, is supplied to compensate for leaks in the housing and any installed equipment. This permanent overpressure prevents any potentially explosive atmosphere in the ambient air from entering the housing. During the purge phase, an internal pressure is achieved.

Any hot spots that may occur on individual components in the control cabinet are monitored by temperature sensors (optional).

For applications in Zone 22/Class II Division 2 (dust), the purge process is omitted because purging would raise explosive dust into a cloud, creating a possible hazard. Instead of pre-purging, the interior of the housing is inspected for dust and cleaned manually if dust is present.

Purge and pressurization systems are particularly suitable for installed equipment that is not approved for use in hazardous areas. The equipment can then be used directly in the hazardous area.

2.2. 7500 System Overview

The 7500 series system consists of a control unit, an enclosure protection vent, and manual or automatic manifold. The control unit has a touch screen display that is menu driven and will easily guide the user in selecting pre-programmed and user-selected variables. The 7500 can be used with a digital valve/manifold system like the 7500-MAN-... or 5500-MAN-... unit to make a fully automatic system. The enclosure pressure and leakage can be monitored and, in the event of a loss in enclosure pressure, the solenoid valve can engage to restore the defined pressure settings and/or alarm for the pressure drop. An easy-to-see display also has 4 LEDs for system condition indication from a distance.

2.3. Control Unit

The 7500 control unit is a control device for Type Z & Ex pz purge systems and is suitable for purge time and pressure monitoring in Class I or II, Division 2, Zone 2 or 22. It controls the volume of purge gas flowing into the explosion-protected control cabinet, and it maintains and monitors an overpressure relative to the ambient air when purging is complete.

The 7500 control unit can be ordered as a stand-alone unit for panel mounting to your enclosure or mounted to a panel with the 7500-MAN-MV-01 valve in a configuration.

Control Unit Components

- 7500 Control Unit
- Mounting bracket, gasket, and screws for enclosure mounting
- Manual



WARNING!

The conduit hub extension, 7500-HUB-01, can only be mounted once to the 7500 control unit. If removed, it cannot be reinstalled. A new conduit unit must be purchased.

2.3.1 Technical Data: Control Unit

Property	Value
General specifications	
Equipment architecture	max enclosure size 12.7 m ³ (450 ft ³)
Operation mode	Fully automatic
Series	7500
Hazardous environment	gas or dust
Supply	
Rated voltage, U _r	20...30 V DC at 0.1 A 90 ... 250 V AC, 50...60 Hz at 0.04 A without solenoid valve. Supply voltage can be line-to-line or line-to-neutral, single phase Overvoltage category II
Power consumption	max. 2.7 W / 7.3 VA without valve
Accuracy	timers: ± 5%
Electrical specifications	
Connection	Screw terminals--see manual for specifications on wire size and torque values

Output	
Output I	
Connection	K1 terminals, 1 x NO
Output type	enclosure power contacts
Contact loading	5 A at 250 V AC, 5 A at 30 V DC, relays must be externally fused Inrush current: 50 A
Output II	
Connection	K2 terminals, 1 x NO
Output type	alarm and control contacts
Contact loading	5 A at 250 V AC, 5 A at 30 V DC, relays must be externally fused Inrush current: 50 A
Output III	
Connection	SV, terminals, L1 powered contact
Output type	Solenoid manifold, contact
Inrush current	5 A
Contact loading	0.5 A at 250 V AC, 0.5 A at 30 V DC, relays must be externally fused
Indicators/settings	
LED indicator	K1: Green—Contact K1 is energized (enclosure contacts) K2: Amber—Contact K2 is energized (alarm/control contacts) P/SV: Blue—Safe pressure P1 (minimum enclosure pressure) P/SV: Amber—Solenoid manifold is energized (purging pressure compensation)
Pneumatic parameters	
Protective gas supply	compressed air or inert gas, 40 µm filter, free from oil
Pressure requirement	supply pressure: 20...120 psig (1.4...8.2 bar)
Enclosure pressure	0...10 in wc (0...25 mbar)
Directive conformity	
Electromagnetic conformity	
Directive 2014/30/EU	EN 61326-1, FCC CFR 47, part 15, subpart B:2017, Class A ICES-003, Issue 6:2016, Class A ITE
RoHS	
Directive 2011/65/EU (RoHS)	EN IEC 63000:2018
Conformity	
Ambient conditions	
Ambient temperature	-40 ... 70 °C (-40 ... 158 °F) at T4 / T80 °C -40 ... 65 °C (-40 ... 149 °F) at T5 / T75 °C -40 ... 50 °C (-40 ... 122 °F) at T6 / T60 °C
Storage temperature	-40 ... 80 °C (-40 ... 176 °F)
Altitude	max. 2000 m

Relative humidity	5 ... 90%, non-condensing
Vibration resistance	5 ... 100 Hz, 1 g, 12 m/s ² , all axes
Impact resistance	30 g, 11 ms, all axes
Mechanical specifications	
Connection type	Electrical: 2 x 1/2 inch NPT (open from factory) 1 x M12 opening (plugged from factory) Pneumatic: High-pressure port (+): 1/8 in NPT Low-pressure port (-): 1/8 in NPT
Degree of protection	Type 4X IP66 (Device is protected against dust and strong jets of water.) No ratings for mounting to enclosure for 7500-MTD-BX...
Pollution degree	Device can be installed in environments up to pollution degree 4.
Material	lens: Makrolon® GP-V polycarbonate screws: AISI 316 (1.4401), 304, or 18-8 stainless steel housing: A380, A356, or 6061-T6 aluminum mounting gasket: Bisco® HT-800 medium cellular silicone mounting tabs: SAE 304 stainless steel M12 plug: 6061-T6 aluminum
Mass	710 g (1 lb 10 oz)
Dimensions	150 x 100 x 50 mm (5.9 x 4 x 2 in)
Data for application in connection with hazardous areas	
Certificate	
Marking	II 3 G Ex ec mc nC [pzc Gc] IIC T6...T4 Gc II 3 D Ex tc mc [pzc Dc] IIIC T60 °C ... T80 °C Dc
Directive conformity	
Directive 2014/34/EU	IEC/EN 60079-0:2018, IEC/EN 60079-2:2014, IEC/EN 60079-7:2015+A1:2018, IEC/EN 60079-15:2019, IEC/EN 60079-18:2015+A1:2017, IEC/EN 60079-31:2014 Supplements: EN 61010-1:2010
UK SI 2016 No. 1107 (EX)	EN IEC 60079-0:2018, EN 60079-2:2014, EN IEC 60079-7:2015+A1:2018, EN IEC 60079-15:2019, EN 60079-18:2015+A1:2017, EN 60079-31:2014
International Approvals	
UL approval	
cULus	Class I, Division 2, Groups A, B, C, D T4 (-40 °C ≤ Ta ≤ 70 °C) Class I, Division 2, Groups A, B, C, D T5 (-40 °C ≤ Ta ≤ 65 °C) Class I, Division 2, Groups A, B, C, D, T6 (-40 °C ≤ Ta ≤ 50 °C) Class II, Division 2, Groups F, G T4 (-40 °C ≤ Ta ≤ 70 °C) Class II, Division 2, Groups F, G T5 (-40 °C ≤ Ta ≤ 65 °C) Class II, Division 2, Groups F, G T6 (-40 °C ≤ Ta ≤ 50 °C)
IECEx approval	Ex ec mc nC [pzc Gc] IIC T6...T4 Gc Ex mc tc [pzc Dc] IIIC T60 °C ... T80 °C Dc

CCC approval	Ex ec mc nC [pzc Gc] IIC T6...T4 Gc Ex mc tc [pzc Dc] IIIC T60 °C...T80 °C Dc Certificate No.: 2020322304002487
General Information	
Supplementary information	Type Examination Certificate, Declaration of Conformity, and instructions have to be observed where applicable. For information see www.pepperl-fuchs.com .

2.3.2 Terminal Connection Data

Connector cross section solid min.	0.2 mm ²
Connector cross section solid max.	6 mm ²
Connector cross section flexible min.	0.2 mm ²
Connector cross section flexible max.	4 mm ²
Connector cross section flexible, with ferrule without plastic sleeve min.	0.25 mm ²
Connector cross section flexible, with ferrule without plastic sleeve max.	4 mm ²
Connector cross section flexible, with ferrule with plastic sleeve min.	0.25 mm ²
Connector cross section flexible, with ferrule with plastic sleeve max.	4 mm ²
Connector cross section AWG min.	24
Connector cross section AWG max	10

2.3.3 Wiring Requirements and Electrical Connections

Wiring Requirements

1. All applicable local and national wiring codes must be followed when wiring the system. See IEC 60079-14 for more information.
2. The power supply to this device shall have a separate disconnect. If placed in the hazardous area, it shall be rated for the area in which it is being installed. Placing the disconnect into the purged enclosure is not a “safe” area, since power needs to be applied to the control unit before the purge cycle is complete.
3. The protective earth wire must be the same size as largest wire used to bring power into the enclosure. Terminate using a ring lug that is properly crimped at the protective earth stud in the bottom of the enclosure. The protective earth terminal torque is 1.36 Nm (12 in-lb).
4. External protective earth ground wire must have minimum cross-sectional area of 4mm. Terminate using properly crimped wire termination at grounding stud on side of housing. Terminal torque: 1.36 Nm (12 in-lb)
5. All wire shall be copper only, rated at a minimum of 80 °C.
6. The wire strip length into the fixed terminal block is 8 mm.
7. For terminal torque requirements, see Section 2.3.7 Torque Requirements: Control Unit.
8. There shall be only one wire per terminal.
9. It is recommended to leave a bit of extra wire loop in the housing.

Electrical Connections

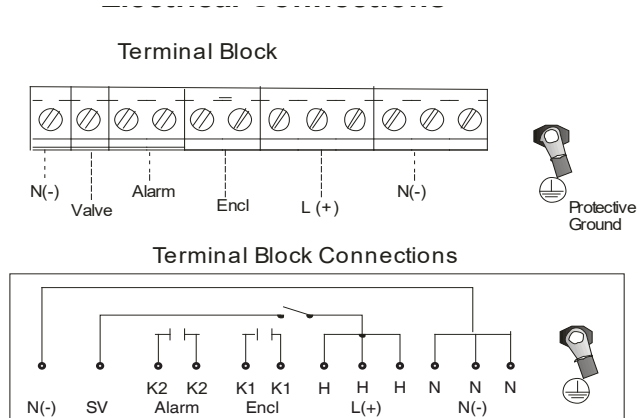

WARNING!

When connecting line-to-line power and K1 and K2 and used to switch the power, the alarm function is not available. For more information, see Section 4.5.3 Programming K2.



WARNING!

When powering the system line-to-line, both lines are present if K3 is used. In this event, both sides of the relay contacts must be fused.



CAUTION!

Use ferrules with all stranded wire types.

2.3.4 Dimensions: Control Units

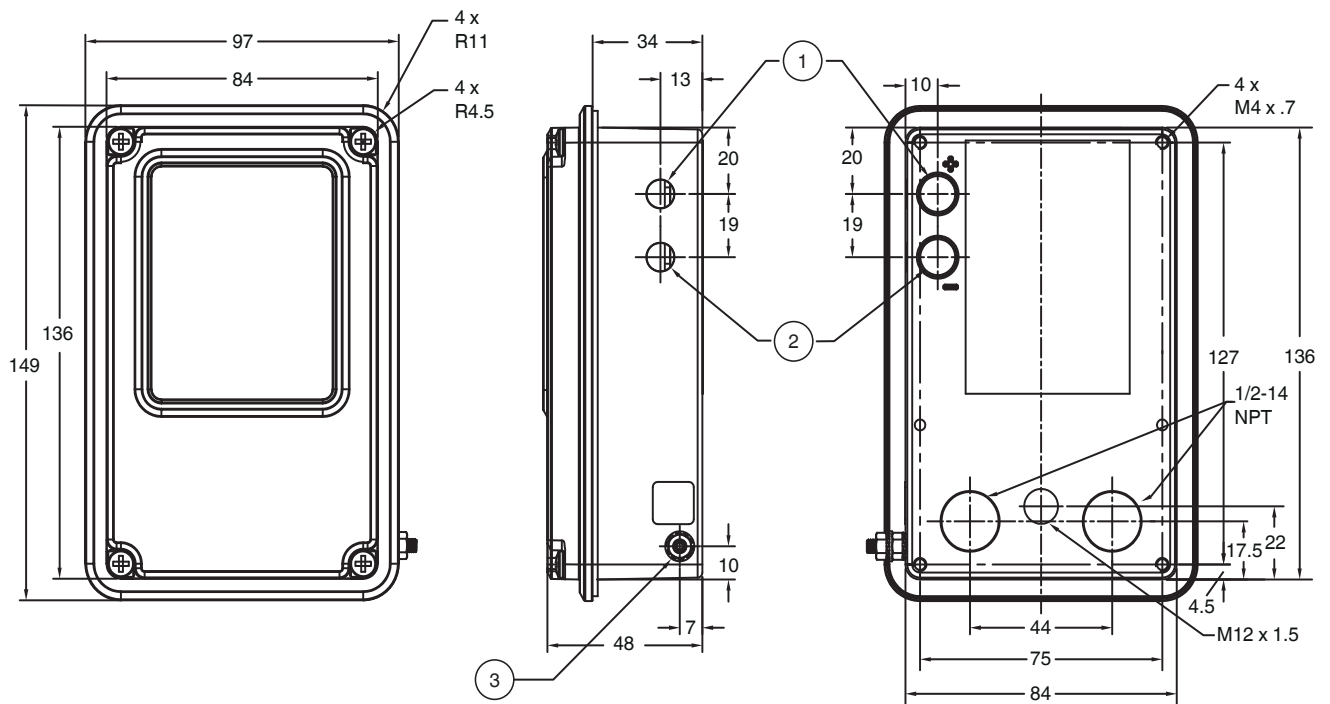

*Dimensions shown in millimeters.

1. High-pressure port (+) 1/8-27 NPT
2. Low-pressure port (-) 1/8-27 NPT
3. Protective earth stud, torque 1.35 Nm (12 in-lb)

2.3.5 Panel Cut-Out Dimensions

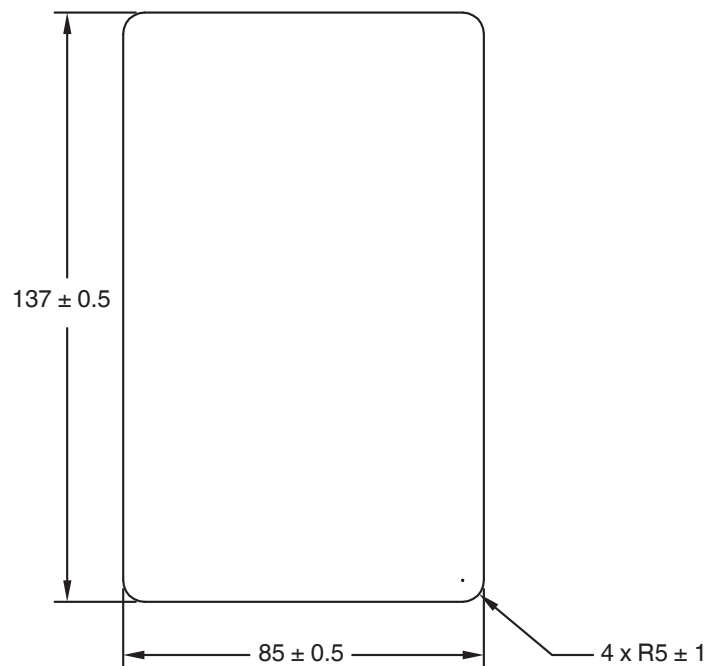

*Dimensions shown in millimeters.

2.3.6 Pressure Kit

- The included pressure kit contains the following components:
- Bulkhead fitting
- O-ring
- Tubing
- Tubing inserts
- Straight connector
- Sintered element for bulkhead fitting
- Panel hole size: 14.7 mm (37/64 inch)



2.3.7 Torque Requirements: Control Unit

Hardware	Torque
Main lid	1.35 Nm (12 in-lb)
M4 screws for mounting bracket	1.35 Nm (12 in-lb)
Screws for mounting HUB	1.35 Nm (12 in-lb)
M12 plug	1.70 Nm (15 in-lb)
Panel mount bracket hardware	Tighten evenly to a uniform gasket thickness of 1.3 mm to 1.7 mm
Set screws to mount control unit in panel	Tighten until control unit is touching metal-to-metal around all edges
Wire terminal	0.5–0.6 Nm
Earth ground (Internal/External)	1.36 Nm (12 in-lb)
Bulkhead fitting nut	0.5 turns past finger tight (Do not overtighten!)
Compression fitting tube end	1-1/4 turns past finger tight

2.3.8 Dimensions: 7500-MTD-* Mount Systems

7500-MTD-BXRW-01 Rectangular External Mount with Control Unit and Manifold

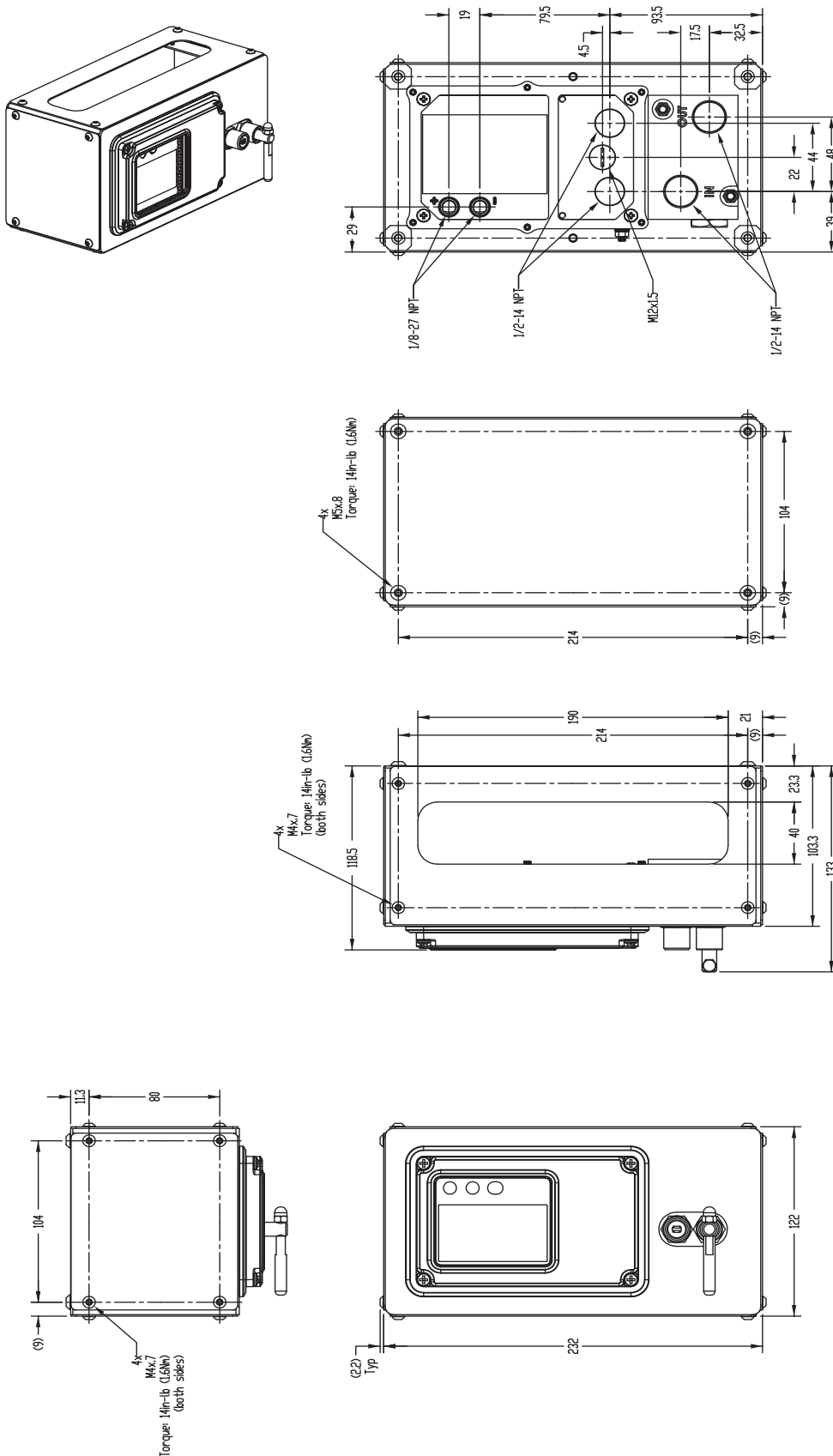

*Dimensions shown in millimeters.

7500-MTD-BMRW-01 Rectangular Panel Mount with Control Unit and Manifold

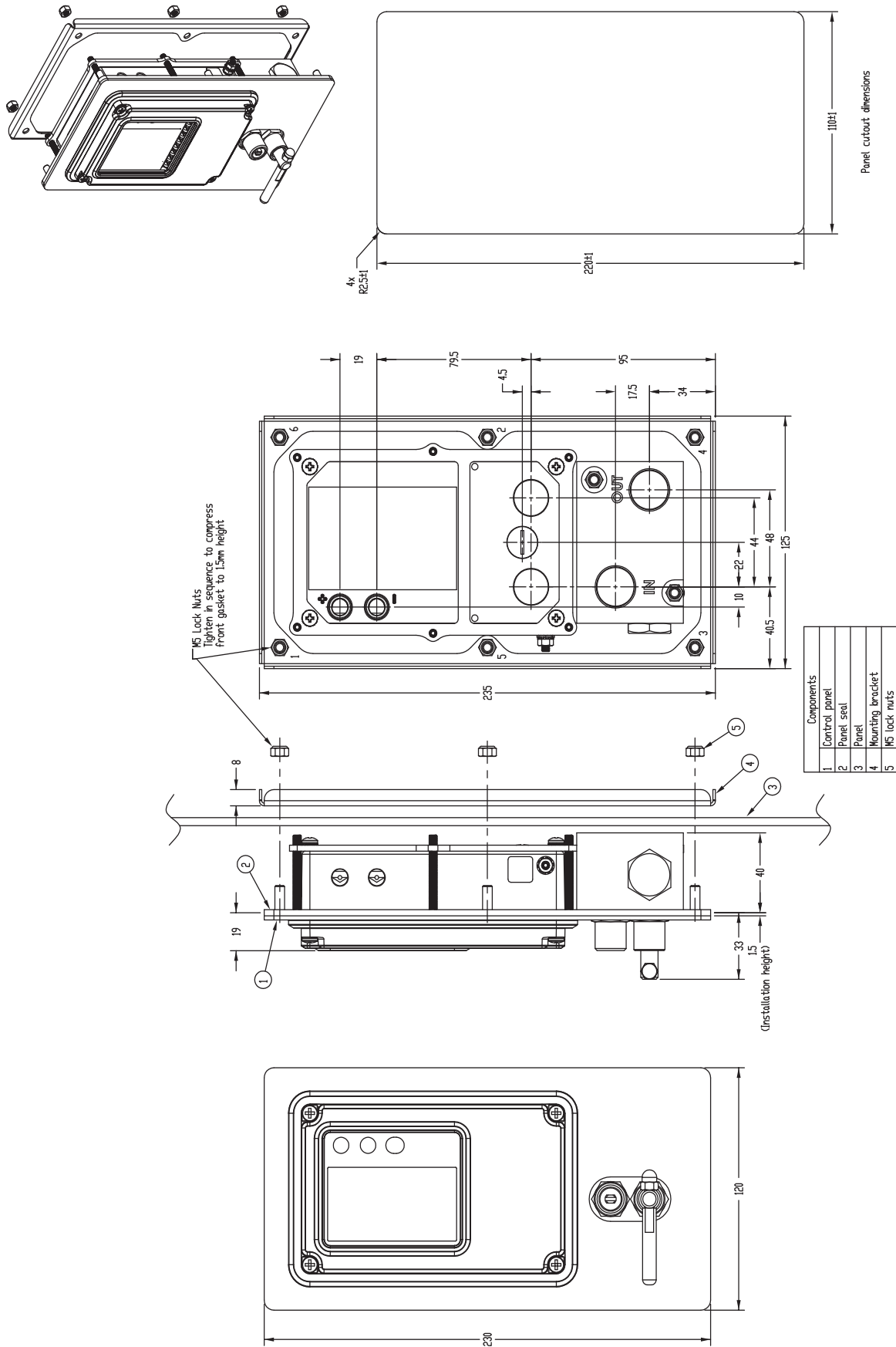

*Dimensions shown in millimeters.

7500-MTD-BXSW-01 Square External Mount with Control Unit and Manifold

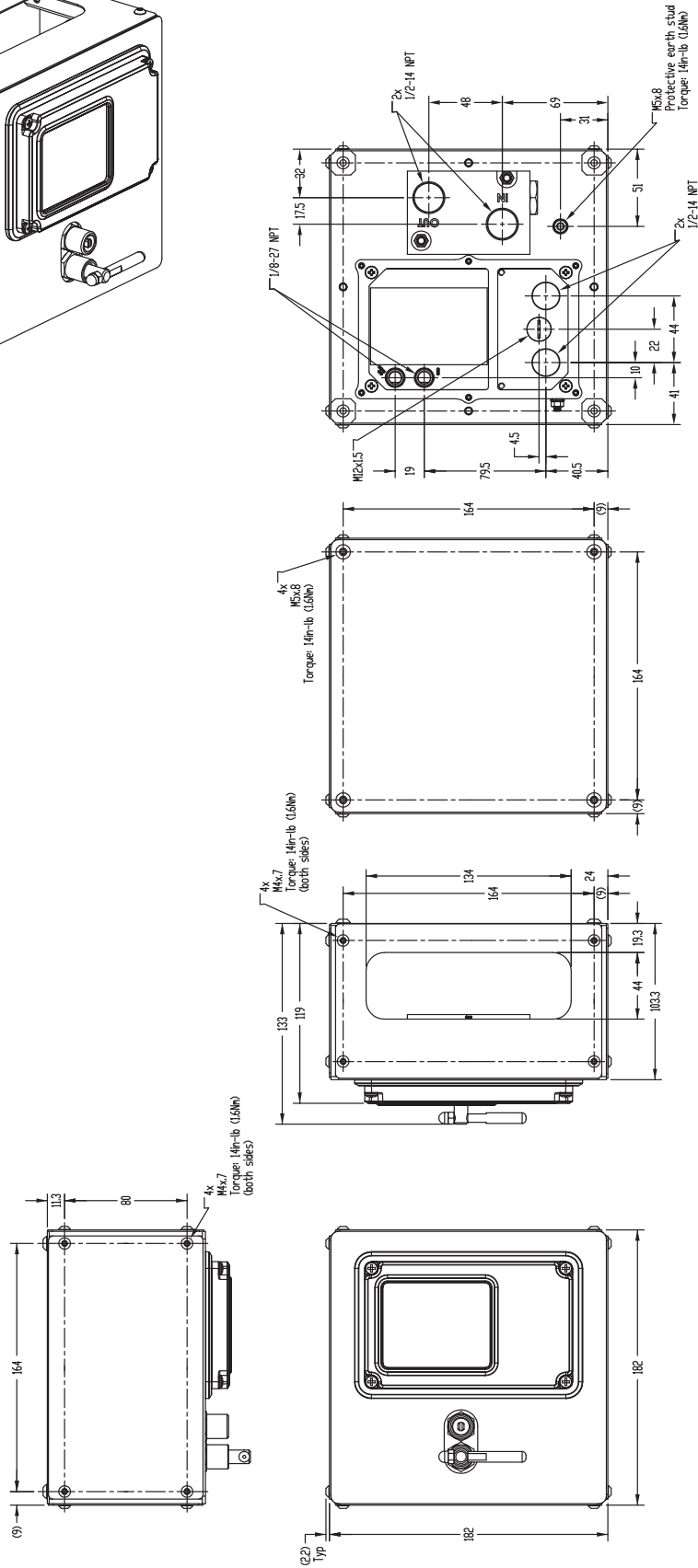
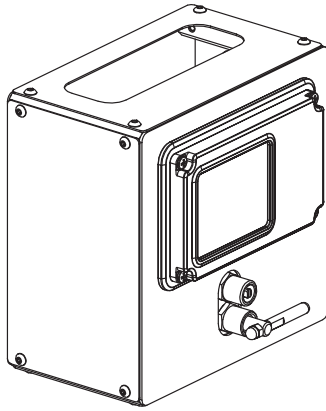

*Dimensions shown in millimeters.

7500-MTD-PMSW-01 Square Panel Mount with Control Unit and Manifold

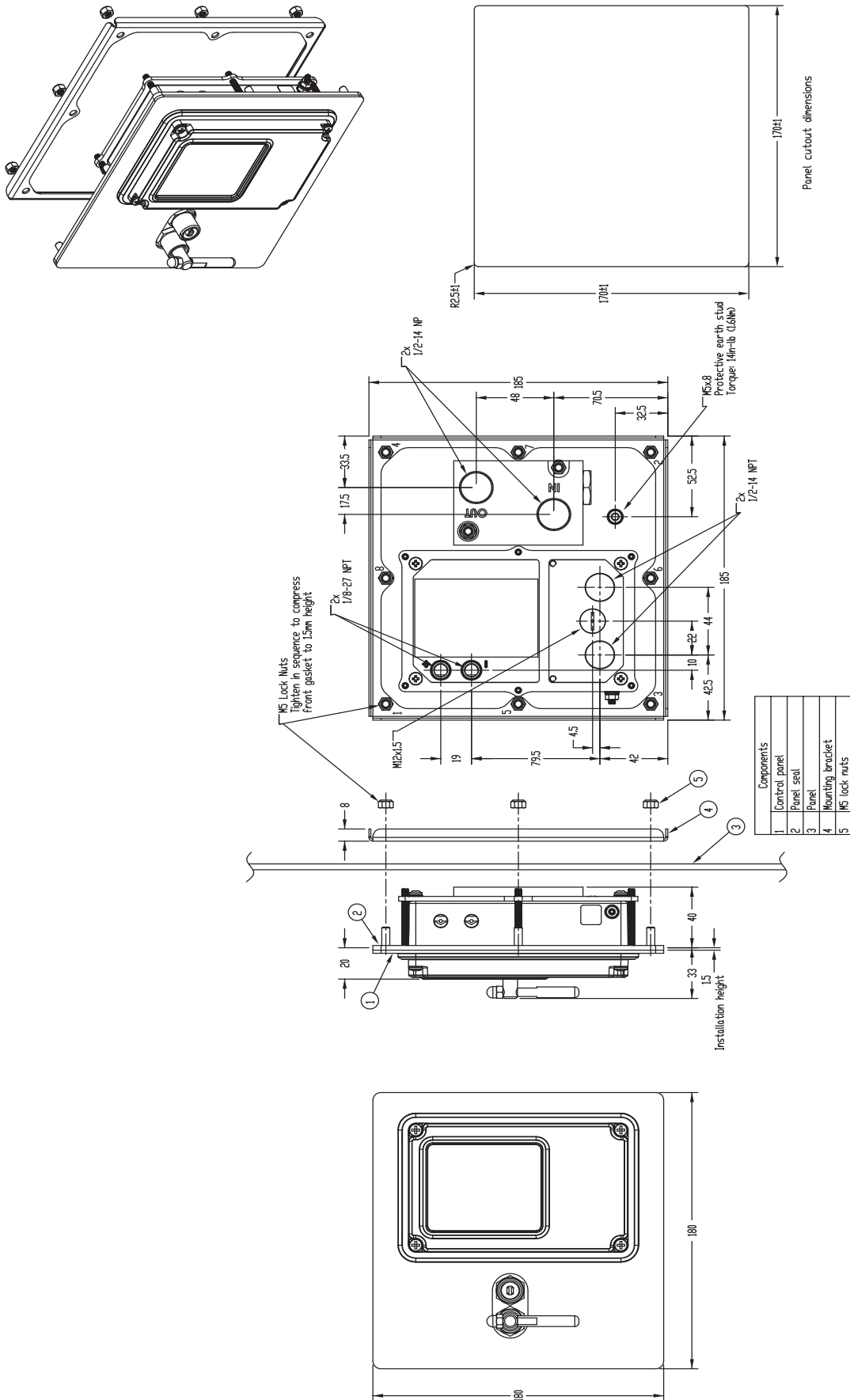

*Dimensions shown in millimeters.

2.3.9 External/Panel Mounting Illustration

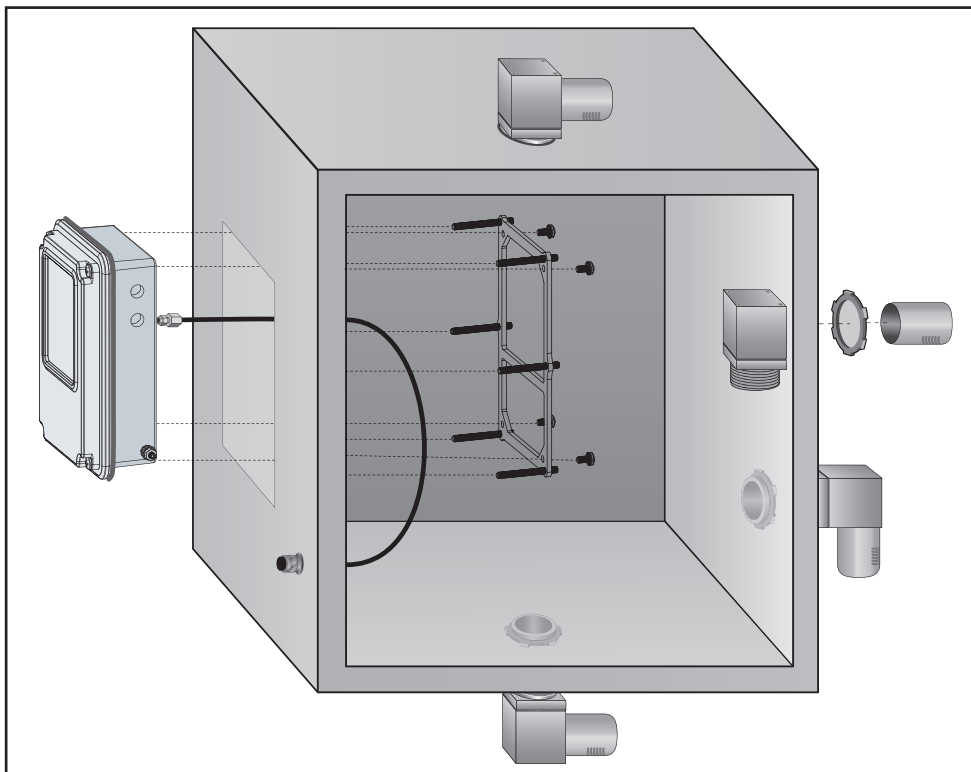
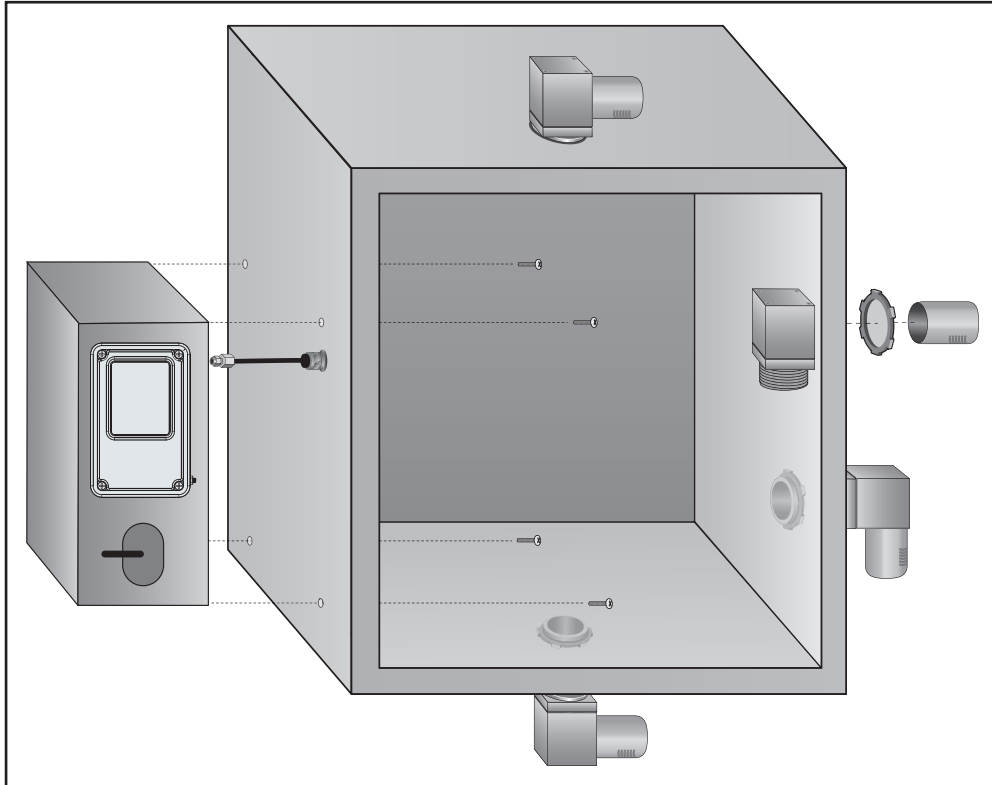

High-pressure port (+): For monitoring the enclosure pressure. This port must always connect the control unit to the monitored enclosure protected by pressurization

Low-pressure port (-): The atmospheric reference. This port shall always be connected such that the air pressure present on this port is the atmospheric pressure surrounding the enclosure being protected by pressurization.

2.4. EPV-7500 Vents

EPV-7500 vents work with the 7500 control unit and manifold to provide a functional, certifiable purge and pressurization system for enclosures. As required by all pressurized enclosure systems, the EPV-7500 vent functions as a pressure relief device and allows the purge gas to exit the enclosure, while still providing a seal when the enclosure is pressurized and operating. The vent also has a spark arrestor, which is required for hazardous areas.



EPV-7500-...-01/02/03



EPV-7500-AA-04

EPV-7500 Components

- EPV-7500 vent with spark arrestor
- Sealing washer and nut for internal or external mounting
- Hex key for removing, attaching, and rotating the vent cap

2.4.1 Technical Data: EPV-7500 Vents

Property	Value
General specifications	
Equipment architecture	max. enclosure size 12.7 m ³ (450 ft ³)
Operation mode	Fully automatic
Series	7500
Hazardous environment	gas or dust
Pneumatic parameters	
Protective gas supply	compressed air or inert gas, 40 µm filter, free from oil
Maximum pressure	depends on the integrity of the enclosure (strength)
Purge flow rate	See tables on pages 26–27.

Flow rate for leakage compensation	<p>EPV-7500-...-01: approx. 25 scfh (707 l/hr) at 0.25 in wc (0.63 mbar) approx. 65 scfh (1838 l/hr) at 0.75 in wc (1.9 mbar)</p> <p>EPV-7500-...-02: approx. 20 scfh (565 l/hr) at 0.25 in wc (0.63 mbar) approx. 48 scfh (1357 l/hr) at 0.75 in wc (1.9 mbar)</p> <p>EPV-7500-...-03 and EPV-7500-AA-04: approx. 15 scfh (424 l/hr) at 0.25 in wc (0.63 mbar) approx. 25 scfh (707 l/hr) at 0.75 in wc (1.9 mbar)</p>
Breaking pressure	<p>EPV-7500-...-01: 0.8 in wc (2.0 mbar) EPV-7500-...-02: 1.4 in wc (3.5 mbar) EPV-7500-...-03: 1.5 in wc (3.8 mbar) EPV-7500-...-04: 1.4 in wc (3.5 mbar)</p>
Directive conformity	
Electromagnetic compatibility	
Directive 2014/30/EU	EN 61326-1, FCC CFR 47, part 15, subpart B: 2017, Class A ICES-003, Issue 6:2016, Class A ITE
RoHS	
Directive 2011/65/EU (RoHS)	EN 63000:2018
Conformity	
Degree of Protection	Directive conformity: see Declaration of Conformity
Ambient conditions	
Ambient temperature	-40 ... 70 °C (-40 ... 158 °F)
Storage temperature	-40 ... 80 °C (-40 ... 176 °F)
Relative humidity	5...90 %, non-condensing
Vibration resistance	5...100 Hz, 1 g, 12 m/s ² , all axes
Impact resistance	30 g, 11 ms, all axes
Mechanical specifications	
Degree of protection	<p>EPV-7500-...-01/02: mounting only Type 4X EPV-7500-...-03: mounting and unit Type 4X</p>
Material	
Housing	<p>EPV-7500-AA... body and cap: 6061-T6 aluminum EPV-7500-SS... body: 6061-T6 aluminum cap: AISI 316L (1.4404) stainless steel</p>
Spark arrestor	304 Stainless steel
Installation	<ul style="list-style-type: none"> - any orientation to enclosure - not gravity dependent - internal and external mounting possible

Mass	approx. 1000 g (2.2 lb)
Dimensions	See dimensions in Section 2.4.3 Dimensions: EPV-7500 Vents
Mounting	EPV-7500-...-01/02/03: 1½ in NPMS thread; mounting hole 50.8 mm (2 in) sealing washer and nut (provided) EPV-7500-...-04: M36 thread; mounting hole 37 mm (1.46 in) with sealing washer and nut (provided)
Data for application in connection with hazardous areas	
Certificate	
Marking	ATEX: part of 18ATEX2025X
International approvals	
cULus	Part of the cULus classified 7500 purge system
IECEX approval	Part of IECEX UL 18.0022X

2.4.2 Flow Rate Curves

The enclosure pressure vs. flow rate curves below represent the EPV-7500...-01, 02, 03, and 04 vents. This corresponds to the enclosure pressure and is independent of the valve used, provided the valve can deliver the flow rate that is required.

The vent flow tables represent the flow rate and enclosure pressure for each vent with a safety margin attached to the values. Enclosure pressure may be less than the tables below for actual measured value. The values below do not take into account leakage from the enclosure; they represent a perfectly sealed enclosure. In most applications, the enclosure will have leakage, which will require higher flow rate into the enclosure to achieve the correct reading. This extra flow will depend on the leakage throughout the enclosure.

There is no restriction of enclosure size for each vent, but leakage rate, flow rate, enclosure pressure, and the 7500 maximum purge time of 254:59 (min:sec) should be considered when applying these vents.

The EPV-7500-...-01 is usually used on large enclosures because it has a higher flow rate and lower back pressure within the enclosure than the other versions. This can reduce the purging time while keeping the enclosure pressure low, which is important for a large enclosure. However, this vent leaks more pressure through its flow control mechanism.

The EPV-7500-...-02 provides a better seal at the vent than the EPV-7500-...-01. The flow rate for purging is less for the same enclosure pressure of the '-01' version.

The EPV-7500-...03 features a flow rate that is less than both the '-01' and '-02' versions, and provides very low leakage, which is recommended for very small enclosures.

EPV-7500-...-01 Vent Flow vs. Enclosure Pressure

ft ³ /min	Inches of water
5	1.28
7	1.44
10	1.64
12	1.80
15	2.10
17	2.30
20	2.53
25	2.95
30	3.50
35	4.15

l/min	mbar
141	3.19
198	3.59
283	4.09
339	4.48
424	5.23
481	5.73
566	6.30
707	7.35
849	8.71
991	10.33

EPV-7500-...-02 Vent Flow vs. Enclosure Pressure

ft ³ /min	Inches of water
5	2.15
7	2.35
10	2.65
12	2.85
15	3.15
17	3.35
20	3.65
25	4.25
30	4.75
35	5.25

l/min	mbar
141	5.36
198	5.85
283	6.60
339	7.10
424	7.84
481	8.34
566	9.09
707	10.58
849	11.82
991	13.07

EPV-7500-...-03 Vent Flow vs. Enclosure Pressure

ft ³ /min	Inches of water
4	2.00
6	2.20
8	2.40
10	2.70
12	3.50
14	4.65
16	6.10

l/min	mbar
113	4.98
169	5.48
226	5.98
283	6.72
339	8.71
396	11.58
453	15.18

EPV-7500-...-04 Vent Flow vs. Enclosure Pressure

ft ³ /min	Inches of water
3	2.50
4	2.70
5	3.10
6	3.40
7	3.80
8	4.20
9	4.60
10	5.00
11	5.50
12	6.10
13	6.80
14	7.70

l/min	mbar
84	6.23
113	6.85
141	7.72
169	8.47
198	9.46
226	10.46
254	11.45
283	12.45
311	13.69
339	15.18
368	16.93
396	19.17

2.4.3 Dimensions: EPV-7500 Vents

EPV-7500-...-01/02 (flapper style)

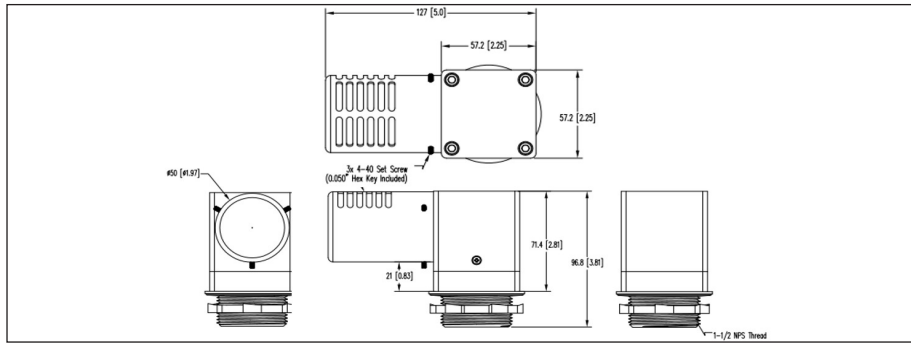

EPV-7500-...-03 (plunger style)

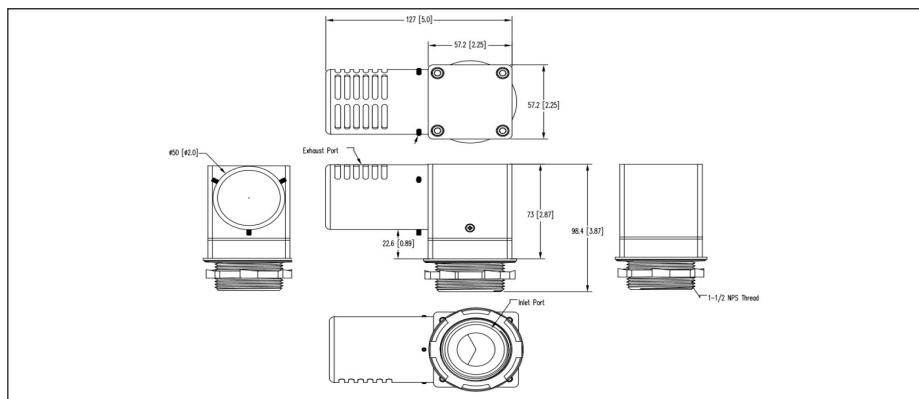

EPV-7500-...-04

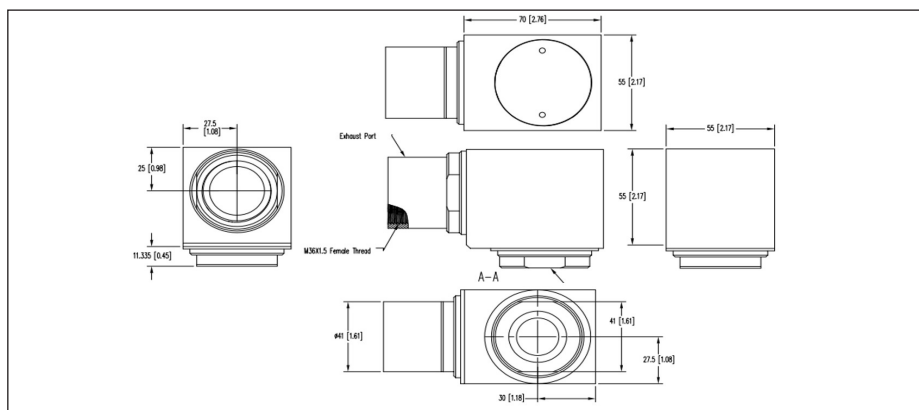

2.4.4 Torque Requirements: EPV-7500 Vents

Hardware	Torque
Sealing washer and nut	0.25–1 turns past finger tight (Do not overtighten!)
Set screws	Secure vent cap by evenly threading in set screws. (Do not overtighten!)

2.5. 7500-MAN-MV-01 Manual Manifold

The 7500-MAN-MV-01 combines in one device a ball valve for purging and a needle valve for pressurizing an enclosure. The ball valve has a handle for easy actuation. To provide security and prevent tampering, the needle valve requires a slot-head screwdriver to set the enclosure pressure.



Note

The 7500-MAN-MV-01 manifold can be used with 7500 series or 5500 series purge and pressurization systems.

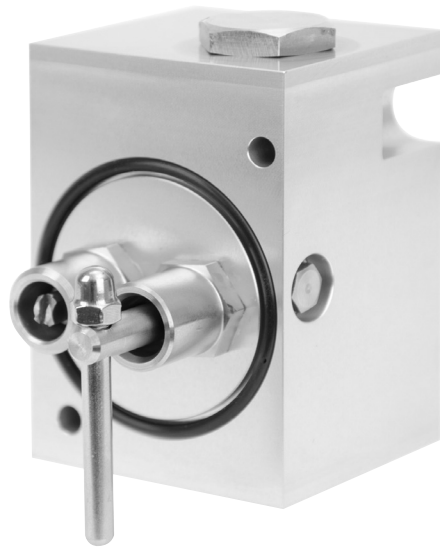

2.5.1 Technical Data: 7500-MAN-MV-01

Property	Value
General specifications	
Equipment architecture	max. enclosure size 450 ft ³ (12.7m ³)
Series	7500
Hazardous environment	gas or dust
Pneumatic parameters	
Protective gas supply	compressed air or inert gas, 40 µm filter, free from oil
Pressure requirement	10...120 psig (0.7...8.2 bar)
Purge flow rate	Pressurization valve: Cv (flow coefficient) = 0.4 Purging valve: Cv (flow coefficient) = 1.4
Connections	inlet/outlet: 1/2 inch NPTF

Ambient Conditions	
Ambient temperature	-40 ... 70 °C (-40 ... 158 °F)
Storage temperature	-40 ... 80 °C (-40 ... 176 °F)
Mechanical Specifications	
Degree of protection	Type 4X
Material	Gasket material: Bisco® HT-800 medium cellular
Mass	Approx. 1.8 kg (4 lb)
Dimensions	See dimensions in Section 2.5.2: Dimensions 7500-MAN-MV-01

2.5.2 Dimensions: 7500-MAN-MV-01

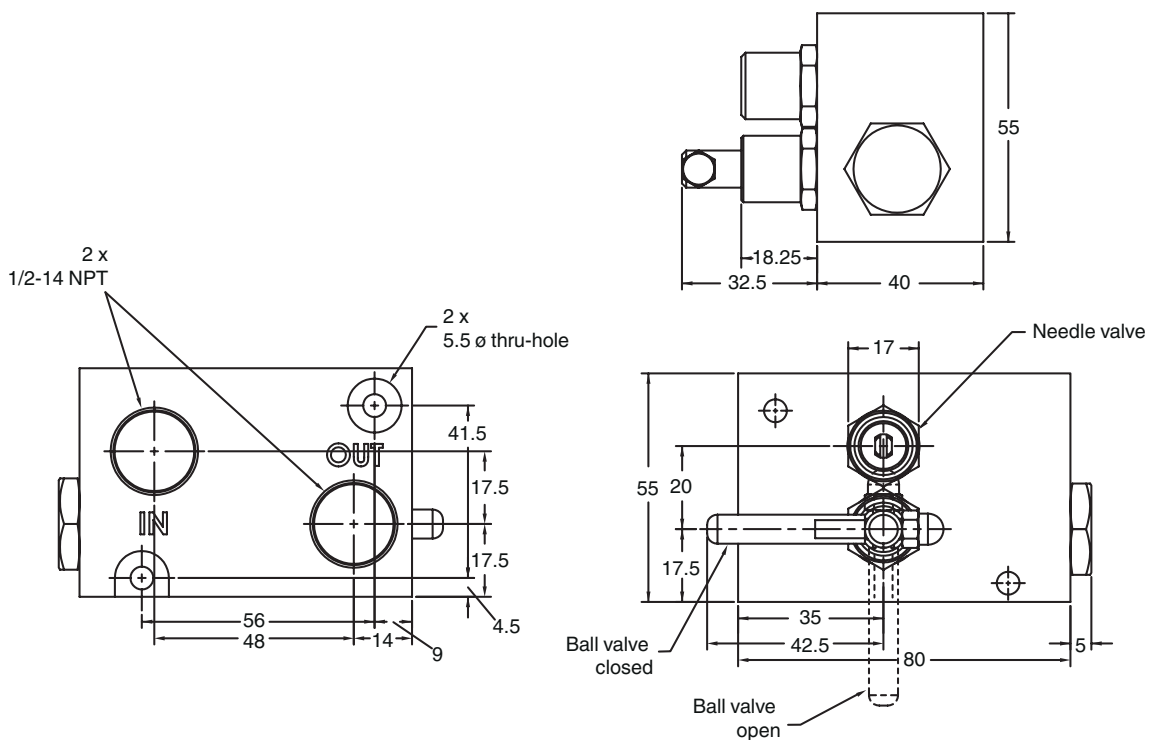

2.5.3 Torque Requirements: 7500-MAN-MV-01

Hardware	Torque
Manifold mounting hardware	Tighten hardware until gasket is compressed 0.64 to 0.96 mm. Use washers provided.

2.6. Automatic Manifolds

Pepperl+Fuchs 5500 or 7500 series automatic manifolds can be used with the 7500 system. The 7500 system is certified with the control unit and the EPV-7500 vents and does not include the manifolds. The 5500 and 7500 manifolds have their own certifications.



Note

Different manifolds are available for different certification requirements. The voltage when selecting a manifold must be specified.

5500-MAN* and 7500-MAN* manifold valves include a solenoid valve for purging and a needle valve for pressurization in one manifold design. When the valve is energized, the solenoid valve is open and allows a high flow rate of protective gas into the enclosure. The amount of flow is controlled by the regulated pressure supply of the protective gas to the manifold. When the valve is de-energized, the flow is through the internal needle valve. The needle valve is adjustable on the 5500-MAN* with the included hex key (for CDUL version of the valve) or slot-head screwdriver (EX01 and CD01 versions of the valves). The needle valve on the 7500-MAN* is adjusted with a slot-head screwdriver.

The solenoid valve is used for purging and leakage compensation, with signals from the 7500 control unit that will have these set points set up by the user.

For the 5500-MAN*, the mounting hardware includes 3/8 inch tube compression fittings mounted on the manifold for input and output flow, 3/8 inch tube compression bulkhead fitting for getting flow into the enclosure, and sealing washers that are certified by UL with bolts to mount the manifold to the enclosure. Also included is 1 meter of 3/8 inch poly tubing with 3/8 inch poly tube stiffener inserts that allow users to connect plastic tubing to compression fittings without collapsing the tubing. Stainless steel tubing can be used with existing fittings. For NEC, ATEX, and IECEx applications, see the type code for the correct model.

For the 7500-MAN*, mounting hardware includes two options (3 mm and 4.5 mm) for jet attachments that can be threaded into the manifold for output flow. The 7500-MAN* carries ATEX/IECEx and CCC certifications.

The 5500 or 7500 manifolds can be used with either the 5500 or the 7500 control unit.

If the user implements a 5500-MAN with the 7500 control unit, they must pay special attention to the fuse size requirements of that solenoid and include an in-line fuse appropriately rated for the hazardous area. Refer to manufacturer's Specific Conditions of Use in certificate IECEx PTB 04.0002X. Users can also use their own pneumatic system, or the 7500-MAN-MV-01 manual manifold.

2.6.2 Components: 5500 Manifolds

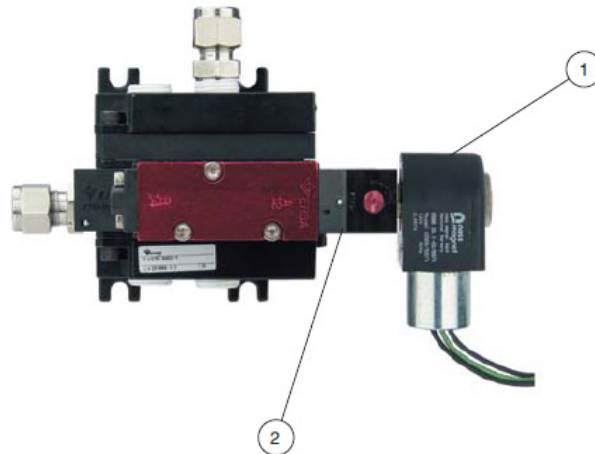

- | | |
|---|---|
| 1 | Solenoid coil for purging |
| 2 | 1/8 inch hex key adjustment for pressurization (included) |



Tubing kit included

Mounting hardware included

5500 manifolds include the solenoid and manual needle valve

- 3/8 inch compression ferrule fittings for inlet and outlet protective gas source
- 3/8 inch compression ferrule bulkhead fitting that attaches to enclosure—for protective gas to inside enclosure
- 3/8 inch poly tubing, length: 2 m
- Inserts for poly tubing to ferrule fitting connection. If stainless steel tubing is used, inserts are not required.
- Hex key for pressurization valve included with 5500-MAN-CDUL version
- Mounting hardware: screws, nuts, and sealing washers





Note

When ordering, note the supply voltage of the 7500 control unit. Order the manifold valves accordingly. Voltages are 24 V DC, 120 V AC, and 220 V AC. 5500 MAN-CDUL manifold valves are only available with 60 Hz operation.

2.6.1 Technical Data: 5500 Manifolds

Property	Value
General specifications	
Operation mode	For automatic purging
Series	5500 and 7500
Hazardous environment	gas or dust
Supply	
Rated power equipment	5500-MAN-CDUL
24 V DC	5.6 W
120 V DC	7.2 VA, 60 Hz
230 V DC	7.2 VA, 60 Hz
Rated power equipment	5500-MAN-CD01
24 V DC	4.6 W
120 V DC	6.8 VA, 60 Hz
230 V DC	6.8 VA 60 Hz
Rated power equipment	5500-MAN-EX01
24 V DC	2.6 W
120 V DC	3.1 VA, 50...60 Hz
230 V DC	3.0 VA, 50...60 Hz
Voltage tolerance	± 10%
Fuse rating	
DC voltage	500 mA
AC voltage	80 mA
Pneumatic Parameters	
5500-MAN-CDUL (only 60 Hz for AC version)	
Protective gas supply	40 µm filtered air or inert gas
Pressure requirement	20 psi (1.4 bar) to 120 psi (8.2 bar)
Purge flow rate (solenoid valves)	Cv (flow coefficient) = 1.4
Pressurization flow (needle valve)	Cv (flow coefficient) = 0.24
Pneumatic Parameters	
5500-MAN-CD01	
Protective gas supply	40 µm filtered air or inert gas
Pressure requirement	20 psi (1.4 bar) to 120 psi (8.2 bar)
Purge flow rate (solenoid valves)	Cv (flow coefficient) = 1.4
Pressurization flow (needle valve)	Cv (flow coefficient) = 0.24
Pneumatic Parameters	
5500-MAN-EX01	
Protective gas supply	40 µm filtered air or inert gas
Pressure requirement	25 psi (1.7 bar) to 115 psi (8.0 bar)

Purge flow rate (solenoid valves)	Cv (flow coefficient) = 1.4
Pressurization flow (needle valve)	Cv (flow coefficient) = 0.24
Mechanical Specifications	
Degree of protection (connector)	Type 7 and 9
Mass	1250 g (2.8 lb)
Dimensions	See dimension drawings.
Mounting Manifold	5500-MAN-CDUL / 5500-MAN-EX01 / 5500-MAN-CD01
Mounting hole	17/64" (6.75 mm) Screws, nuts, and sealing washers
Material	
Housing	Anodized aluminum
3/8 inch compression fittings	AISI 316L (1.4404) stainless steel
Pressure ports	3/8 inch NPTF
Bulkhead fitting	AISI 316L (1.4404) stainless steel
Mounting bolts	1/4-20, 316 stainless steel
Sealing washers	
Pneumatic connection type	Pneumatic
Input port	3/8 inch tube compression fitting
Output port	3/8 inch tube compression fitting
Electrical Connection	
5500-MAN-CD	1/2" NPTF thread connection with 24 inch (0.61 m) flying leads
5500-MAN-EX01	3 m cable
Hazardous Location Approvals	
5500-MAN-CDUL	
UL approval	Class I Division 2, Group A–D Class II Division 2, Group F+G
CSA approval	Class I Division 2, Group A–D Class II Division 2, Group F+G
Temperature Class	T3C
Hazardous Location Approvals	
5500-MAN-CD01	
FM approval	Explosionproof: Class I Division 1, Group A–D, T4 DIP: Class II Division 1, Groups F+G, T4 Nonincendive: Class I Division 2, Groups A–D, T4 Suitable for Class II Division 2, Groups F+G, T4
CSA approval	Class I Division 1, Groups A–D; Class II, Groups E, F, G Class I Division 2, Groups A–D
Hazardous Location Approvals	
5500-MAN-EX01	
EU-type examination certificate (marking)	 II 2 G Ex mb IIC T5 Gb  II 2 D Ex mb tb IIIC T95 °C Db IP65 Protection by encapsulation

IECEX approval

II 2 G Ex mb IIC T5 Gb
II 2 D Ex mb tb IIIC T95 °C Db IP65
Protection by encapsulation



WARNING!

Incoming power must be fused. If power is line-to-line, both must be fused.
See Section 2.3.3: Wiring Requirements and Electrical Connections for more information.

2.6.3 Dimensions: 5500 Manifolds

5500-MAN-CDUL

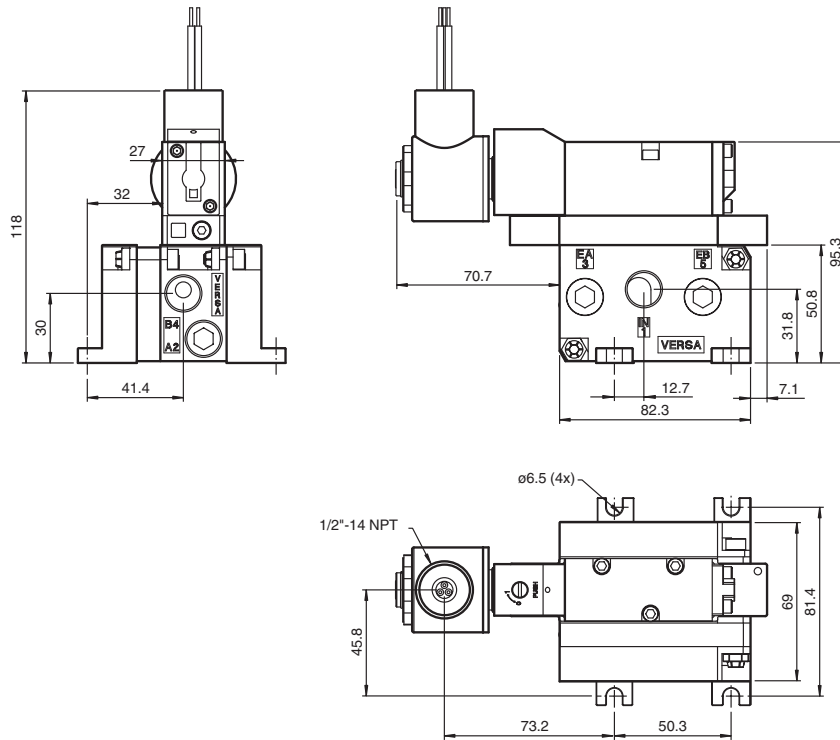

*Dimensions shown in millimeters.

5500-MAN-EX01

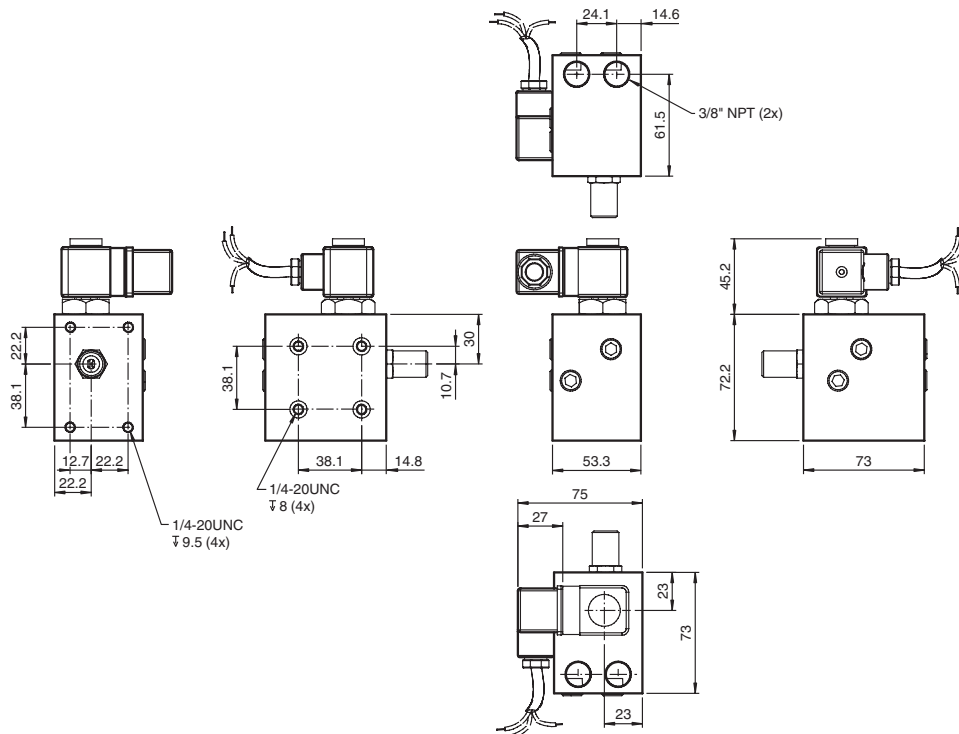

*Dimensions shown in millimeters.

5500-MAN-CD01

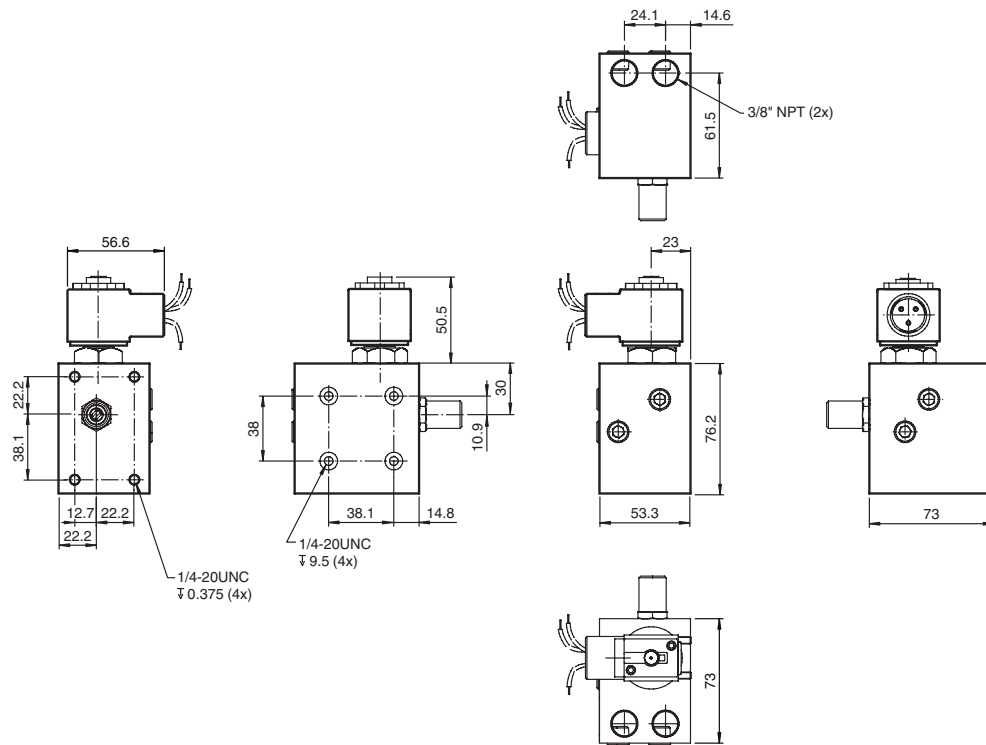





*Dimensions shown in millimeters.

2.6.4 Torque Requirements: 5500 Manifolds

Hardware	Torque
Screws, nuts, and sealing washer	8.5 Nm (75.2 in-lbs)
Bulkhead fitting nut	40 Nm (350 in-lbs)
Compression fitting tube end	1 1/4 turns past finger tight
Knurled nut (solenoid)	1.2 N-m (10.6 in-lbs)
Plastic cable gland (solenoid)	Hand tight
Mounting screws (solenoid)	Secure solenoid with screw. Do not over tighten!

2.6.5 Technical Data: 7500 Manifolds

Property	Value
General specifications	
Operation mode	For automatic purging
Series	7500
Hazardous environment	gas or dust
Supply	
Rated voltage	230 VAC ± 10% 115 VAC ± 10% 24 VDC ± 10%
Power consumption	230 VAC @ 1.8 W 115 VAC @ 9 W 24 VDC @ 9 W
Pneumatic parameters	
Protective gas supply	instrument grade air or inert gas
Pressure requirement	T6 version: 0.2 bar (2.9 psi) to 4.0 bar (58 psi) T4 version: 0.2 bar (2.9 psi) to 16 bar (232 psi)
Purge flow rate	Kv value water 3.8 m ³ /h
Connections	G1/2 (13 mm)
Ambient conditions	
Ambient temperature	
Temperature class T4/130° C	-40 °C ... +55 °C (-40 °F ... 131 °F)
Temperature class T6/180° C	-40 °C ... +50 °C (-40 °F ... 122 °F)
Storage temperature	-40 °C ... +80 °C (-40 °F ... 176 °F)
Mechanical specifications	
Connection type	Inlet/outlet size: G1/2 (13 mm) Jet size: 3.0 mm and 4.5 mm (included)
Degree of protection	IP65
Material	Body: brass Valve (internal): brass, stainless steel, and plastic Seal: NBR
Hazardous location approvals	
EU-type examination certificate (marking)	 II 2 G Ex mb IIC T4/T6 Gb  II 2 D Ex mb tb IIIC T130 °C/T6 Db Protection by encapsulation
IECEx approval	 Ex mb IIC T4/T6 Gb  Ex mb IIIC T130 °C/T80 °C Db

2.6.6 Components: 7500 Manifolds

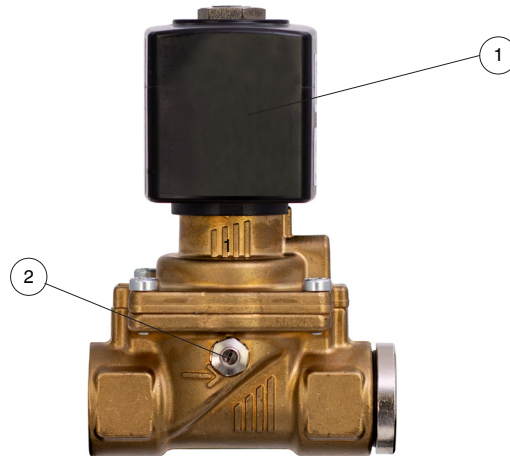

1	Solenoid coil for purging
2	Slot-head screwdriver adjustment for pressurization (included)

2.6.8 Dimensions: 7500 Manifolds

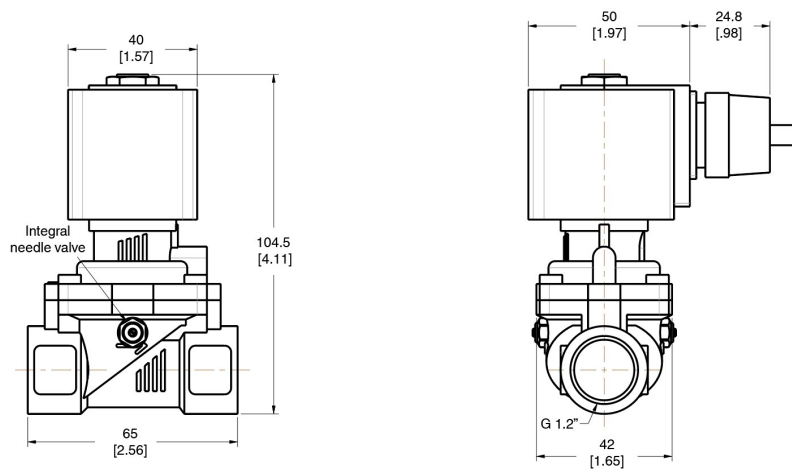

2.6.7 Torque Requirements: 7500 Manifolds

Hardware	Torque
Plastic cable gland (solenoid)	Hand tight
Fitting (G 1/2 BSPP)	40 Nm (350 in-lbs)

3. Installation and Operation

The 7500 series control unit, vent, and manifold can be universally mounted to the customer enclosure. The 7500-01-AA-STD-UNV-PNO is panel-mounted to the enclosure. An included bracket provides a Type 4X / IPX66 mounting. The 7500-MTD-PM... includes the 7500-01... control unit and 7500-MAN-MV-01 mounted onto a flat panel that is then panel-mounted to the enclosure with the included bracket and gasket for a Type 4X / IPX66 mounting. The 7500-MTD-BX... includes the 7500-01.. control unit and 7500-MAN-MV-01 mounted onto an enclosure that can then mount externally to the main enclosure. The EPV-7500 vent can be externally or internally mounted with just the cap showing for exhausting the pressure.

The 7500 system is designed to allow the enclosure to be located in Zone 2 or 22, Class I or II, Division 2 hazardous locations to operate safely by first making them safe internally. This is done either by purging out the hazardous gas or by manually cleaning out the dust hazard and then pressurizing the enclosure so that the internal pressure prevents the hazardous atmosphere from entering. The 7500 control unit has a differential pressure sensor within the unit that is pneumatically connected to the protective enclosure to provide pressure for evaluation of the enclosure pressure and the flow through the enclosure during purging. If pressure is lost, then power can remain on. An indication by an alarm or display has to notify the operator of the condition. If the pressurized enclosure has been opened or a positive pressure has not been maintained, then purging for hazardous gas or cleaning the enclosure out for dust atmospheres is required. The flow measurement is evaluated by using the pressure in the enclosure and the known measured flow in the tables through one of the vents selected.

3.1. For Gas Atmospheres

If the protective enclosure has been opened or has been subjected to the hazardous atmosphere, purging is required to flush out the hazardous gas that may be inside the protective enclosure. A protective gas is introduced into the enclosure so that the pressure builds up and is exhausted through the enclosure. The measurement of flow is achieved by the 7500 control unit pressure sensor measuring enclosure pressure and using that pressure for the flow tables of the vent selected and enclosure size. Each vent has an enclosure pressure vs. flow table for enclosure size that can be used to determine flow rate. This flow rate is used to determine the purge time required to make the protective enclosure safe.



Note

The flow rate tables generated for each vent are measured on a completely sealed enclosure with no leakage from the enclosure. In real applications, there will be some leakage from the enclosure, which will depend on the integrity of the seals and door windows, etc. As the enclosure pressure increases, the leakage may also increase. Always plan on more flow from the protective gas to achieve enclosure pressure because of the leakage.

After purging, the flow into the enclosure can be reduced so that just a small flow is used for leakage compensation for pressurization of the enclosure.

3.2. For Dust Atmospheres

If the protective enclosure has been opened or has been subjected to the hazardous atmosphere, the enclosure must be manually cleaned of all combustible dust, closed, and pressurized before supplying power to the enclosure. For dust atmospheres, a higher pressure is required for pressurization and is reflected in the pressure range within the 7500 programming setup.

3.3. For Gas and Dust Atmospheres



DANGER!

EN and IEC 60079-2 standards do not provide these requirements. Special consideration is needed, and a proper certification body or authority having jurisdiction must be consulted.

3.4. Setting up the System

1. Ensure that the system meets all electrical, mechanical, and pneumatic connections before operation. Refer to this manual and standards for explanation of requirements.
2. Apply power to the 7500 series system.
3. Program the 7500 system using the user-interface display on the front of the 7500 control unit. See Chapter 4 for instructions.



Note

This step is for initial setup of the 7500 system.

4. Make sure control valve is closed before applying pressure to the system.
5. Connect a regulated pressure source to the valve. Set the regulated pressure to 30 psig (2 bar) or lower. Do not exceed the maximum pressure for the valve and tubing that is being used.
6. Slowly open the needle valve on the control valve system so that the pressure is above P1. If one of the automatic manifolds, 5500-MAN or 7500-MAN, is being used, the solenoid valve will energize either before P1 or after. This depends on the purge program being used. See Section 4.4.
7. Check the EPV vent to make sure air is flowing from it. If not, check for any obstructions or improper installation.
8. The system is ready to operate.

3.5. Operating the System

1. Set up the system according to the preceding instructions.
2. For Flush Programs 1 through 4 (hazardous gas environments), purging is required.
 - a. Seal the pressurized enclosure.
 - b. Set enclosure pressure to a value above P1.
 - c. When using the 5500-MAN... manifold, the manifold valve is connected to the SV1 output. When the enclosure pressure is greater than P1, SV1 energizes the solenoid valve for purging. When using the 7500-MAN... or other manual valves, initiate the purging valve.
 - d. Adjust the regulated pressure so that enclosure pressure is above P3 (purging starts).
 - e. For the 5500-MAN manifold, after purging, the needle valve can be re-adjusted to the user's preference, but it must be above the P1 value.
3. For Flush Program 5 (hazardous dust environment), purging is not required.
 - a. The inside of the enclosure must be cleaned of all combustible dust.
 - b. The enclosure is sealed.
 - c. Adjust the enclosure pressure above P1.
4. If enclosure pressure is above P1, power to the enclosure will be energized.
5. If enclosure pressure drops below P1, power must be disconnected. If power is to remain on, an alarm must be initiated and located near an operator.
6. To energize the pressurized enclosure again, repeat the above sequence.



DANGER!

All 7500 pressurization systems require EPV-7500...vents for pressure relief.



DANGER!

When accessing the user-interface display, the area must be free of hazardous gas and/or combustible dust. The lid to the 7500 housing must be attached and properly tightened for operation in a hazardous area.



DANGER!

Explosion hazard—do not open when an explosive atmosphere is present. Substitution of components may impair suitability for use in hazardous (classified) areas.



AVERTISSEMENT!

Risque d'explosion—ne pas ouvrir lorsqu'une atmosphère explosive est présent. La substitution de composants peut rendre ce matériel inacceptable pour les de utilisation dans des Zones (Classifiées) dangereuses.



Note

At ambient temperatures below -20 °C, the display of the 7500 control unit may not be visible. However, the unit and LED indicators will still function properly.

4. Programming

4.1. Touchscreen Display

Use the touchscreen on the front of the 7500 control unit to program the system:

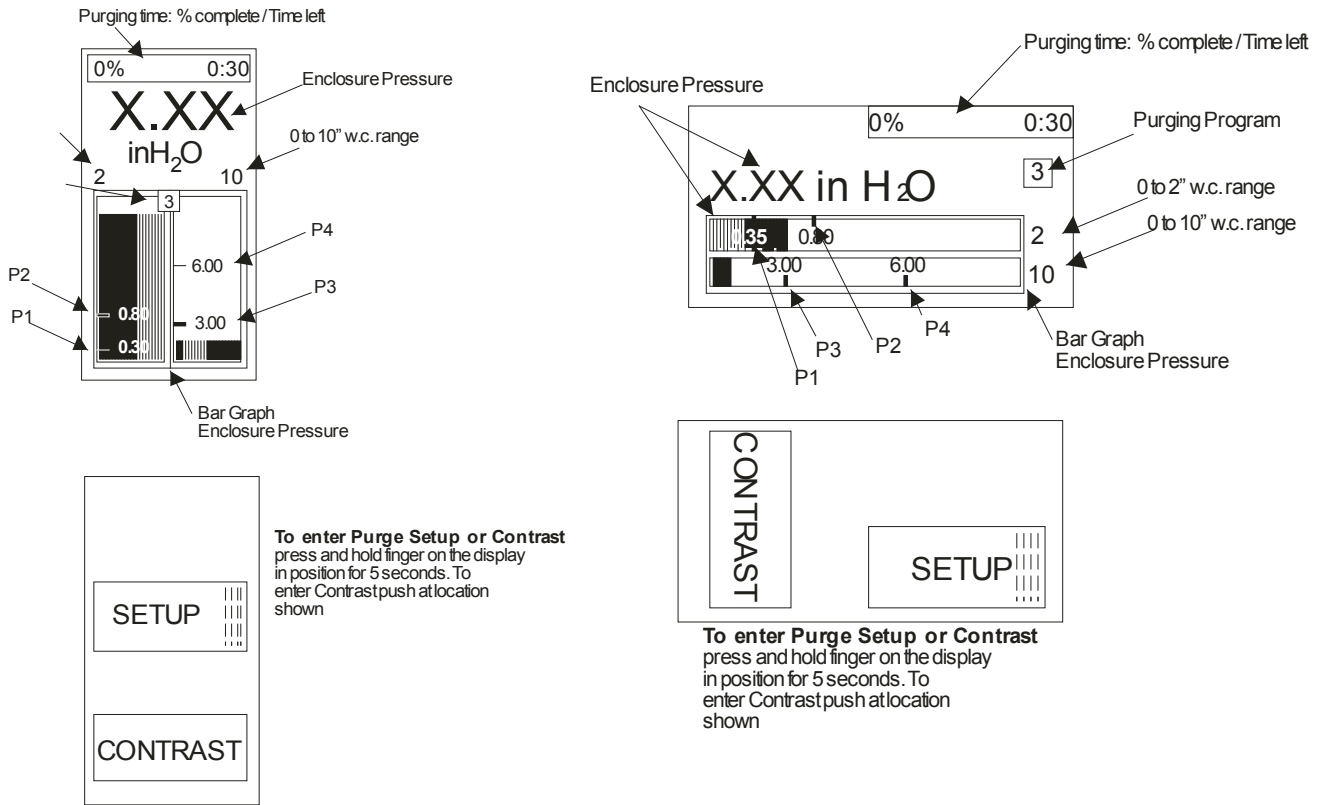

4.1.1 Contrast and Back Light

Adjusting the Contrast

To adjust the contrast, push on the display in the area marked "contrast". The up and down arrows adjust the contrast level: UP increases and DOWN decreases.

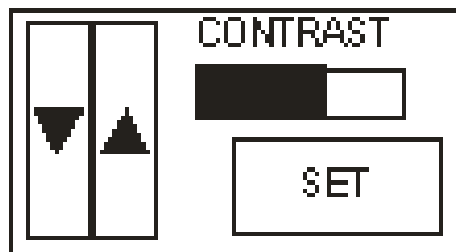

LCD Backlight

The LCD backlight is always on. It cannot be turned off or adjusted.

Program settings are saved on non-volatile memory in the CPU. Settings are unaffected by power down and reset function. Default values are stored and can be restored.



Note

To save settings and exit setup mode, hold the set button to return to normal mode. Changes to settings take effect immediately. Entering the incorrect password will exit setup mode.



WARNING!

Do not change program setting in hazardous areas.

4.1.2 LED Indication

	LED Color	Description
K1	Green	Contact K1 is energized
K2	Amber	Contact K2 is energized
P/SV	Blue/amber	Blue: safe pressure Amber: valve on

4.2. Default Settings

Display	Description	Default Values
PASSWORD / SET	Enter password to access purge settings	0000
PURGE / PROGRAM	Up to 5 programs to select	3
PURGE / TIME	Time required for purging	00:30
For model 7500-01-*		
ENCLOSUR / PRESS P1	Enclosure pressure P1	
	P1 for gas	0.12 inch w.c. (0.30 mbar)
	P1 for dust	0.52 inch w.c. (1.29 mbar)
ENCLOSUR / PRESS P2	Enclosure pressure P2	0.8 inch w.c. (1.99 mbar)
ENCLOSUR / PRESS P3	Enclosure pressure P3	2.5 inch w.c. (6.22 mbar)
ENCLOSUR / PRESS P4	Enclosure pressure P4	4.5 inch w.c. (11.2 mbar)
For model 7500-03-*		
ENCLOSUR / PRESS P1	Enclosure pressure P1	
	P1 for gas	0.23 inch w.c. (0.57 mbar)
	P1 for dust	0.63 inch w.c. (1.57 mbar)
ENCLOSUR / PRESS P2	Enclosure pressure P2	0.8 inch w.c. (1.99 mbar)
ENCLOSUR / PRESS P3	Enclosure pressure P3	2.5 inch w.c. (6.22 mbar)
ENCLOSUR / PRESS P4	Enclosure pressure P4	4.5 inch w.c. (11.2 mbar)
LEAKAGE / HYST	Compensates for leakages	0.2 inch w.c. (0.5 mbar)

PROGRAM / K2	Various parameters to activate K2 contacts	K1 ¹
SHUT-OFF / DELAY	Delay in turning K1 off when P<P1	0 sec
UNITS / M I	M for metric units I for imperial units	I
CHANGE / PASSWORD	Change existing password	
RESTORE DEFAULTS	Factory restore	
DISPLAY ROTATION	Landscape or portrait	Portrait

1. *K1 is not an alarm output. See Section 4.5.3: Programming K2 for programming details on what controls K2.

4.3. Menu Structure

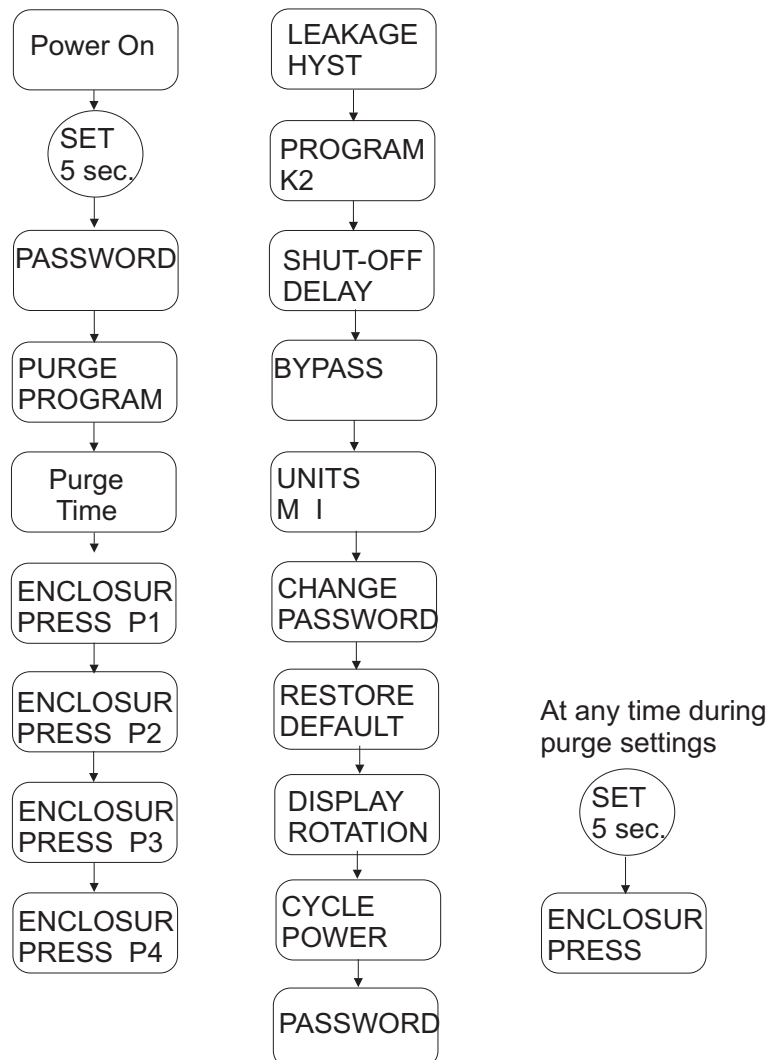

4.4. Purge Programming Setting

There are 5 program selections for system operation. Programs 1 through 4 are for hazardous gas environments and require purging. The fifth program is for hazardous dust environments that require cleaning the enclosure, then pressurizing.

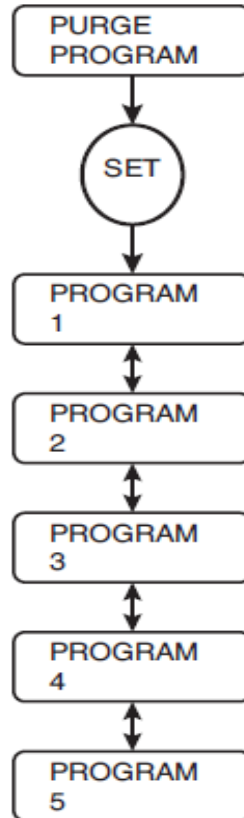

4.4.1 Program 1

Program 1 is used in hazardous gas atmospheres.

Sequence of Events for Program 1

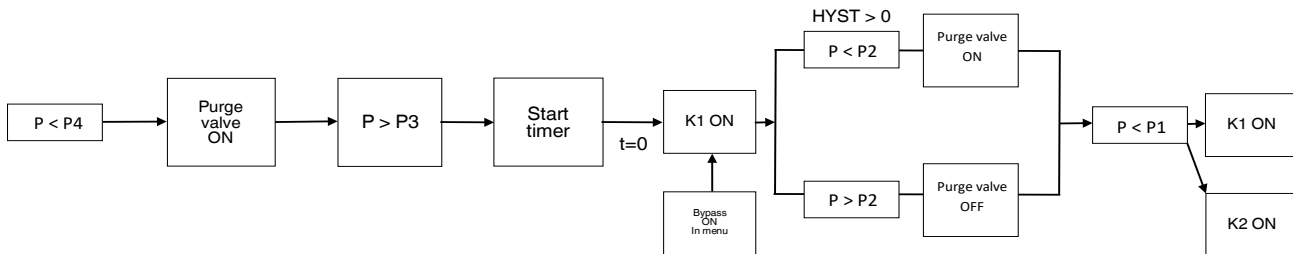

Pre-Purge

- The purge valve (SV) is immediately energized regardless of enclosure pressure.
- If enclosure pressure goes above P4 during purging, SV will shut off but will energize when below P4. Oscillation of SV may be noticed.
- Setting the pressurization valve on the manifold must be done after purging, or the power to SV will have to be interrupted to set this pressure. The solenoid valve on the manifold is immediately energized before this pressure can be set.
- The purge timer begins counting down when the enclosure pressure is greater than P3. Enclosure pressure must remain greater than P3 to purge successfully. If the pressure drops below P3 at any time, or for any length of time, the purge timer is reset and will not begin counting down until pressure is greater than P3.

Operation Mode

- After the purge timer counts down, the SV shuts off and K1 is energized.
- If enclosure pressure drops below P2, the SV is energized and will stay energized for the value of HYST (% , leakage compensation). If HYST is set to 0, leakage compensation is turned off.
- If enclosure pressure drops below P1, K1 remains on and an alarm shall be implemented. K2 can be set to P- or Alarm to indicate below safe or operating pressure.
- If enclosure pressure goes above P4, K1 remains. If K2 is set up as Alarm, K2 will energize.



WARNING!

If K1 is used to energize power to the enclosure, K1 will remain energized if pressure is below P1 during system operation. An alarm is required and must be located such that an operator will be notified of the alarm.

4.4.2 Program 2

Program 2 is used in hazardous gas atmospheres.

Sequence of Events for Program 2

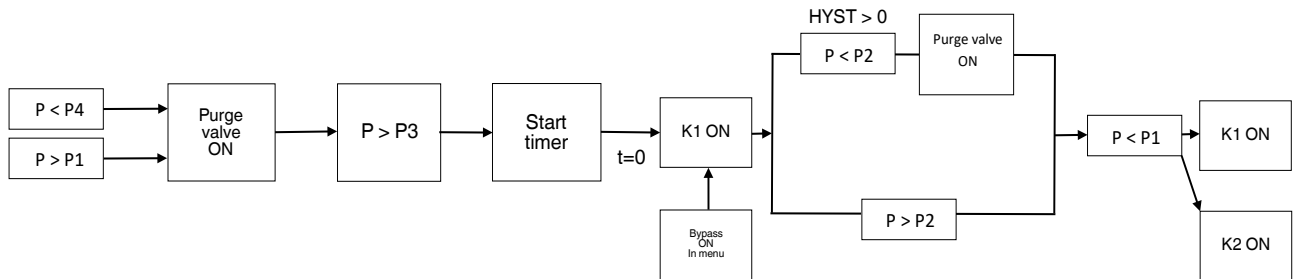

Pre-Purge

- The purge valve (SV) is energized when enclosure pressure is greater than P1.
- If enclosure pressure goes above P4 during purging, the SV shuts off but will energize when below P4. Oscillation of SV may be noticed.
- Setting the pressurization valve on the manifold has to be done after purging, or the power to SV will have to be interrupted to set this pressure. The solenoid valve is energized once enclosure pressure is above P1. Adjusting the pressurization valve before the solenoid valve is energized will allow the enclosure pressure to be above P1 when purging is completed. Fine adjustment of P1 can be achieved after purging when the solenoid valve is off.
- The purge timer begins counting down when enclosure pressure is greater than P3 and must remain greater than P3 to purge successfully. If the pressure drops below P3 at any time, or for any length of time during purging, the purge timer is reset and will not begin counting down until pressure is greater than P3.

Operation Mode

- After the purge timer counts down, the SV shuts off and K1 is energized.
- If enclosure pressure drops below P2, the SV is energized and will stay energized for the value of HYST (% , leakage compensation). If HYST is set to 0, leakage compensation is turned off.
- If enclosure pressure drops below P1, K1 remains on and an alarm shall be implemented. K2 can be set to P- or Alarm to indicate below safe or operating pressure.
- If enclosure pressure goes above P4, K1 remains. If K2 is set up as Alarm, K2 will energize.



WARNING!

If enclosure pressure is below P1 when K1 is used to provide power to the enclosure during operation, K1 will remain energized. An alarm is required and must be located such that an operator will be notified of the alarm.

4.4.3 Program 3

Program 3 is used in hazardous gas atmospheres.

Sequence of Events for Program 3

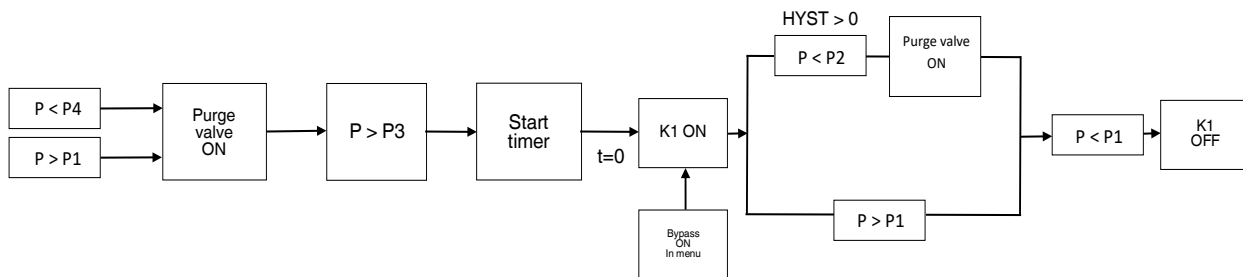

Pre-Purge

- The purge valve (SV) is energized when enclosure pressure is greater than P1.
- If enclosure pressure goes above P4 during purging, the SV will shut off but will energize when below P4. Oscillation of SV may be noticed.
- Setting the pressurization valve on the manifold must be done after purging, or the power to SV will have to be interrupted to set this pressure. The solenoid valve is energized once enclosure pressure is above P1. Adjusting the pressurization valve before the solenoid valve is energized allows the enclosure pressure to be above P1 when purging is completed. Fine adjustment of P1 can be achieved after purging, when the solenoid valve is off.

Operation Mode

- After the purge timer counts down, the SV shuts off and K1 is energized.
- If enclosure pressure drops below P2, the SV is energized and will stay energized for the value of HYST (% , leakage compensation). If HYST is set to 0, leakage compensation is turned off.
- If enclosure pressure drops below P1, K1 turns off immediately or after the Shutdown delay timer times out. K1 remains off until the enclosure goes through a successful purging.
- If enclosure pressure goes above P4, K1 remains. If K2 is set up as Alarm, K2 will energize.

4.4.4 Program 4

Program 4 is used in hazardous gas atmospheres.

Sequence of Events for Program 4

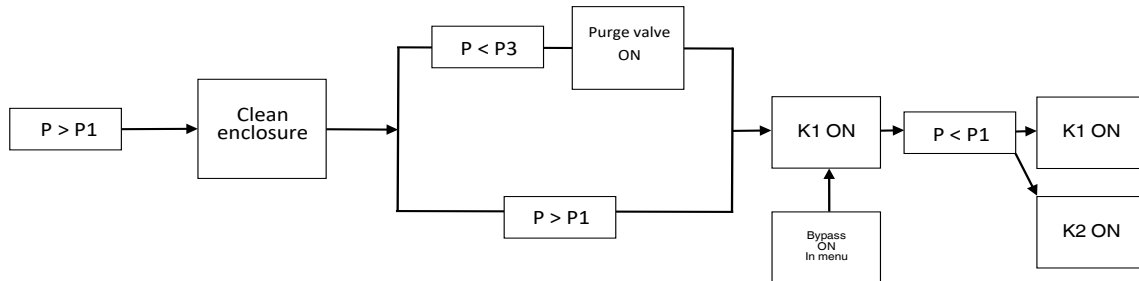

Pre-Purge

- The purge valve (SV) is immediately energized regardless of enclosure pressure.
- If enclosure pressure goes above $P4$ during purging, the SV shuts off but will energize when below $P4$. Oscillation of SV may be noticed.
- Setting the pressurization valve on the manifold has to be done after purging, or power to SV will have to be interrupted to set this pressure. The solenoid valve on the manifold is immediately energized before this pressure can be set.
- The purge timer begins counting down when enclosure pressure is greater than $P3$, and it has to remain greater than $P3$ to purge successfully. If the pressure drops below $P3$ at any time, or for any length of time during purging, the purge timer is reset and will not begin counting down until pressure is greater than $P3$.



WARNING!

If enclosure pressure is below $P1$ when $K1$ is used to provide power to the enclosure during operation, $K1$ will remain energized. An alarm is required and must be located such that an operator will be notified of the alarm.

Operation Mode

- After the purge timer counts down, the SV shuts off and $K1$ is energized.
- If enclosure pressure drops below $P3$, the SV is energized and will stay energized for the value of HYST (% leakage compensation). If HYST is set to 0, leakage compensation is turned off. However, Program 4 is usually used when a continuous purging through the enclosure is required during operation mode.
- If enclosure pressure drops below $P1$, $K1$ remains on and an alarm will sound. $K2$ can be set to P- or Alarm to indicate below safe or operating pressure.
- If enclosure pressure goes above $P4$, $K1$ remains. If $K2$ is set up as Alarm, $K2$ will energize.

4.4.5 Program 5

Program 5 is used in combustible dust atmospheres.

Sequence of Events for Program 5

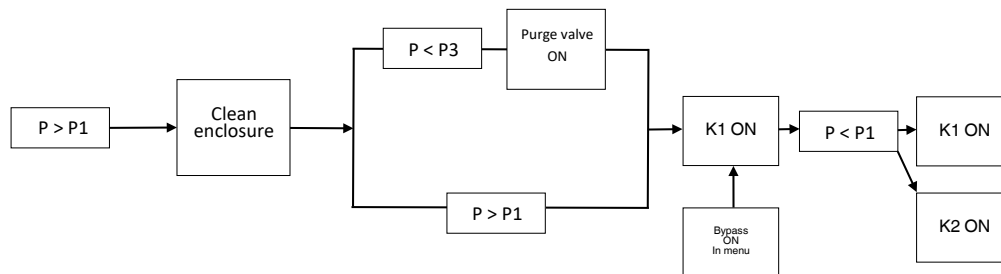

Pre-Purge

- The purge valve (SV) does not come on during this operation. In a dust atmosphere, purging is not required. Instead, the enclosure must be cleaned of all combustible dust and then pressurized.
- The menu screen will show “CLEAN ENCLOSURE.” The enclosure should be cleaned and then pressurized before pressing the SET button.
- The enclosure pressure has to be above P1 for the SET button to work.

Operation Mode

- After cleaning out and pressurizing the enclosure, the menu shows “CLEAN ENCLOSURE.” To see the enclosure pressure, press the Down or Up button. Pressing the SET button will energize K1.
- If enclosure pressure drops below P2, the SV is energized and will stay energized for the value of HYST (% , leakage compensation). If HYST is set to 0, leakage compensation is turned off. Compensation for leakages is allowed in a dust atmosphere because the enclosure is safe at this point.
- If enclosure pressure drops below P1, K1 remains on and an alarm will sound. K2 can be set to P- or Alarm to indicate below safe or operating pressure.
- If enclosure pressure goes above P4, K1 remains. If K2 is set up as Alarm, K2 will energize.



WARNING!

If enclosure pressure is below P1 when K1 is used to provide power to the enclosure during operation, K1 will remain energized. An alarm is required and must be located such that an operator will be notified of the alarm.

Program	1		2		3		4		5	
Purging	K1	SV	K1	SV	K1	SV	K1	SV	K1	SV
P<P1	off	on	off	off	off	off	off	on	off	off
P1<P<P2	off	on	off	on	off	on	off	on	off	off
P2<P<P3	off	on	off	on	off	on	off	on	off	off
P3<P<P4	off	on	off	on	off	on	off	on	off	off
P>P4	off	off	off	off	off	off	off	off	off	off
										Clean activates above P1
After purging										
P<P1	on	on	on	on	off	off	on	off	on	off
P1<P<P2	on	on	on	on	on	on	on	on	on	on
P2<P<P3	on	off	on	off	on	off	on	on	on	off
P3<P<P4	on	off	on	off	on	off	on	off	on	off
P>P4	on	off	on	off	on	off	on	off	on	off



Note

Shutdown timer and bypass affect the status of K1 and SV.

See the explanation for each to determine effects on K1 and SV.

4.5. Purging Timer

4.5.1 Determining Purge Time

Programming the Purging Timer (MIN:SEC)

1. Calculate the purging time using the formulas and examples in Chapter 4.
2. Enter the purging time using the UP and DOWN buttons and SET.
3. To change the purging time by 1-second increments, press the UP or DOWN button.
4. To make purging time faster, hold down the button continuously. Purging time will advance faster, as the button is held down for longer times (in 5 seconds, 1 min, 5 min increments).

Maximum purge time is 254:59.

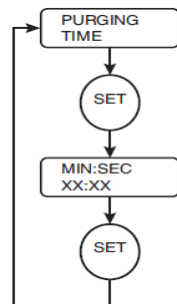

To make sure the enclosure is safe from the hazardous atmosphere, the inside of the enclosure has to be free of the hazardous atmosphere and pressurized before the equipment inside can be powered.

The first step in this process is to get rid of the hazardous atmosphere within the enclosure.

For a dust atmosphere, the inside of the enclosure must be cleaned out and then pressurized. Because most vents on a pressurized enclosure have a spark arrestor, purging is not the method used. The dust must be cleaned out manually or with a vacuum that is rated for the area. Alternatively, it must be cleaned out in a non-hazardous area.

For gas atmospheres, the enclosure is purged by introducing a flow of protective gas (compressed air, or Inert gas) through the enclosure to make it safe. Depending on the standards that are being used to evaluate the effectiveness of the purging operation, the volume of protective gas through the enclosure determines the amount of time for purging. The exchange of protective gas is related to the volume of the enclosure, the number of exchanges, and the flow rate through the enclosure.

Below is an equation for determining the purging time:

$$(\text{number of volume exchange}) \times (\text{volume of the enclosure}) / \text{flow rate} = \text{purging time}$$

The number of volume exchange depends on

- the item being purged and
- the standard it is being evaluated to.

Number of exchanges	Class/Division (NFPA 496)	Zone (60079-2)
4	X	n/a
5	n/a	X
10 (motors)	X	X

EXAMPLE

P3=	2.6 inches water	6.5 mbar
Vent=	EPV-7500-...-02 table for P3: EPV-7500-...-02, see Section 2.4.2	
Enclosure volume=	10 ft ³	282 liters
Flow rate from P3= (see table)	11.3 scfm	320 liters/min
NFPA (Class/Division)	4 volume exchange	4 volume exchange
Zone (ATEX, IECEx)	5 volume exchange	5 volume exchange
NFPA:	$4 \times 10 \text{ ft}^3 / 11.3 \text{ scfm} = 3.6 \text{ min}$	$4 \times 282 \text{ liters} / 320 \text{ l/min} = 3.6 \text{ min}$
Zone:	$5 \times 10 \text{ ft}^3 / 11.3 \text{ scfm} = 4.5 \text{ min}$	$5 \times 282 \text{ liters} / 320 \text{ l/min} = 4.5 \text{ min}$
Motors:	$10 \times 10 \text{ ft}^3 / 11.3 \text{ scfm} = 8.9 \text{ min}$	$10 \times 282 \text{ liters} / 320 \text{ l/min} = 8.9 \text{ min}$

The 7500 control unit has a purge timer and is user-selectable through the menu.

The purge timer is activated when the enclosure pressure goes above P3. The pressure must always be above P3 for the timer to continue until it counts down to 000:00. If the enclosure pressure drops below P3 for any amount of time, then the timer is reset to its starting value and will not start counting down until pressure is above P3.

The flow rate for P3 value can be found on the graphs for vent flow in Section 2.4.2. The flow rate for P3 depends on the EPV-7500 vent that is being used.

The more the enclosure leaks pressure, the higher the flow rate into the enclosure required to achieve the P3 threshold.

4.5.2 Pressure Settings

4.5.2.1 Minimum Enclosure Pressure “P1”

When enclosure pressure drops below P1 during operation mode, either the K1 enclosure contact must be interrupted or the K2 alarm contact must be activated.

4.5.2.2 Alarm Pressure “P2”

If enclosure pressure drops below P2 during operation mode, the solenoid valve will energize until pressure goes above $P2+HYST$, if leakage compensation has been implemented by setting a HYST value.

If leakage compensation is not used, K2 can be programmed to energize when pressure drops below the P2 set point.

P2 can be adjusted to above P1 and below P3 values.

4.5.2.3 Purging Pressure “P3”

The purging timer starts when enclosure pressure is above P3. If the enclosure pressure is above P3, purging will start and finish uninterrupted. If the enclosure pressure is below P3, the purging timer will not start. If the enclosure pressure drops below P3 during purging, the purging timer will immediately reset to its beginning time and will not start timing down until enclosure pressure is above P3. P3 can be adjusted to above P2 and below P4 values.

4.5.2.4 Maximum Internal Pressure “P4”

If enclosure pressure is above P4, the display will read ‘MAX’ to indicate that maximum pressure has been achieved. Regardless of the action of the solenoid valve (purging, leakage compensation), the solenoid valve will de-energize and will not come on until enclosure pressure goes below P4. This action may cause the solenoid valve to oscillate on and off. If this happens, it should be noted as a maximum pressure problem.

If K1 was on before P4 was reached, it will remain on after enclosure pressure is above P4. P4 is adjusted above P3. Maximum setting is 9.99 in wc (24.86 mbar).

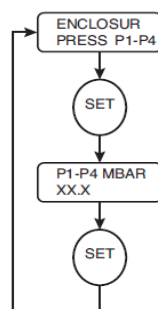

Leakage Compensation Hysteresis “HYST”

In operation mode, there may be excess leakage of pressure from the enclosure due to a faulty seal or gasket. There could also be enclosure pressure loss due to a drop in regulated line pressure. The leakage compensation option allows the SV to turn on to compensate for these unintentional leakages. Depending on the purge program being used, the SV will energize when below P^* and will de-energize when above $P^* + \text{HYST}$.



Note

$P^* = P2$ for Programs 1,2,3, and 5.

$P^* = P3$ for Program 4.



Note

If leakage compensation is not required, set HYST to '0'.

Values for Hysteresis (HYST)

Inches W. C.	mbar
0	0
0.2	0.5
0.4	1.0
0.6	1.5
0.8	2.0
1.0	2.5
1.2	3.0
1.4	3.5
1.6	4.0
1.8	4.5
2.0	5.0

Example

Units are in mbar, hysteresis = 1.5, then SV is on at $P2$ and turns off at $P2 + 1.5$

The HYST unit of measurement is the units being used.

If HYST = 1.5, then this is 1.5 mbar.

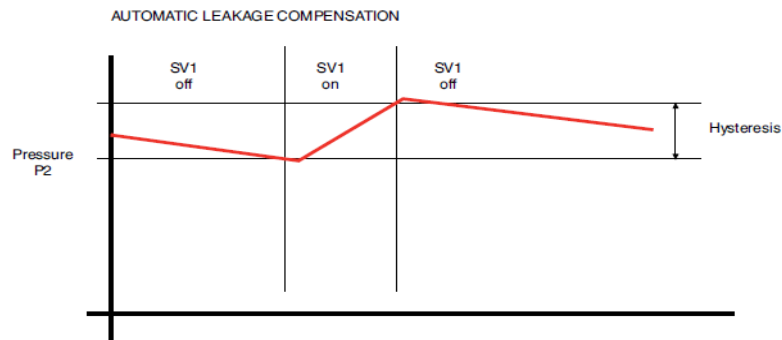
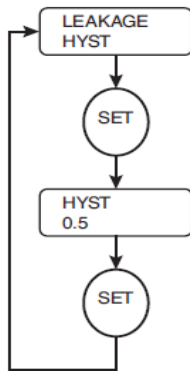

4.5.3 Programming K2

The K2 contact output can be programmed for various settings that are chosen by the user.

For Type Z and Ex pz systems, power to the pressurized enclosure can remain on if pressure goes below the minimum allowed pressure, but an audible and/or visual alarm must be generated to notify the operator of a problem.

K2 can be used to generate the signal for the alarm when properly configured. Alarm function based on any pressure point (P1 to P4 is not available when K2 is mapped to K1, purging or bypass). Additionally, the K2/ALARM LED indication is not an alarm indication when K2 is mapped to these functions.

When K2 is mapped to a function that is not an alarm for loss of safe pressure, the power to the enclosure must be automatically removed, or an external method of alarming is required.

User-Selectable Settings for K2

Setting	Function
K1	Switches simultaneously with K1 ¹
P1+	Switches on when pressure exceeds P1
P1-	Switches on when pressure falls below P1
P2+	Switches on when pressure exceeds P2
P2-	Switches on when pressure falls below P2
P3+	Switches on when pressure exceeds P3
P3-	Switches on when pressure falls below P3
P4+	Switches on when pressure exceeds P4
P4-	Switches on when pressure falls below P4
Purging	Switching on when purge timer starts and shuts off at the end of purging
Bypass	Switches on when the bypass function is activated
All Alarms	Comes on when P1-, P4, Bypass

¹ This mode is intended for use when the system is controlling a line-to-line power source into the protected enclosure and both power lines need to be switched.

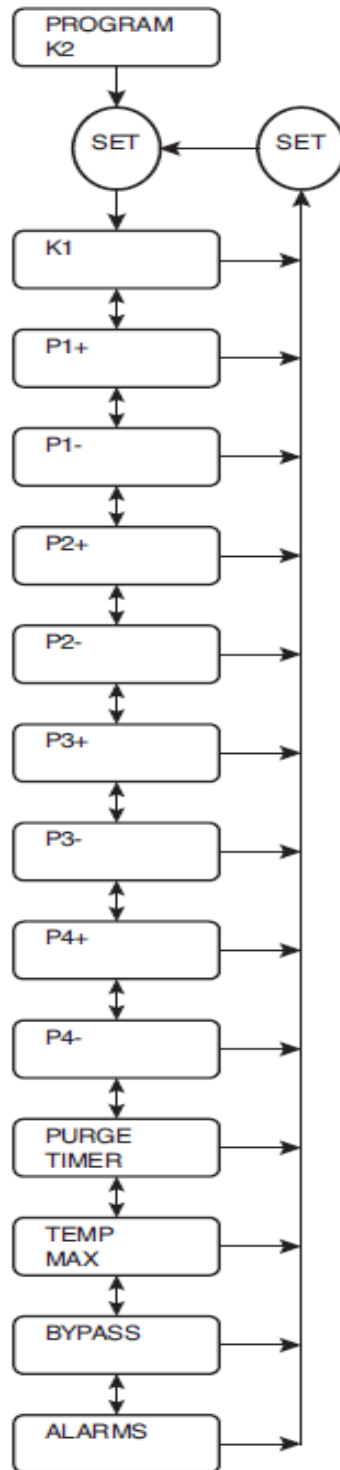

4.6. Shutdown Timer for K1

The shutdown timer is used in the operation mode and allows K1 to remain on for the duration of this setting when enclosure pressure drops below the minimum setting of P1. If the pressure goes above P1 during the countdown, the timer is reset. If the pressure remains below P1 for the duration of the countdown, K1 will shut off.

The shutdown timer is effective only for Program 3, in which K1 de-energizes when enclosure pressure is below P1. The other programs allow power to the enclosure to remain on when pressure is below P1, with an alarm generated to the operator.

The default value is 0 seconds. The range is 0 to 300 seconds.

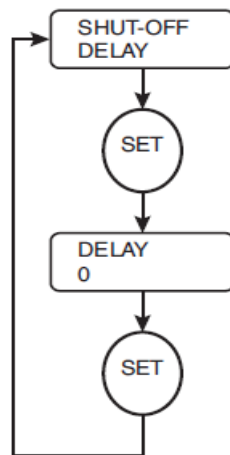

4.7. Bypass

The Bypass mode allows power to the enclosure to be energized when the enclosure pressure is below the minimum pressure P1. This can be useful in commissioning the enclosure or working on the enclosure when it is open.

The Bypass option has two modes of operation to choose from.

Mode		Description
N	No	Bypass is not enabled.
Y	Yes	Bypass is implemented using the purge settings menu. By selecting 'Y', the system will go into bypass and will turn on K1. In the 'Y' mode, K1 will be energized before the system goes through a successful purge. This mode can be useful in commissioning the enclosure during start up. This mode is on when it is selected and the menu stays in the purge settings mode. If the user exits from the purge settings mode, then the 'Y' is automatically changed to 'N' and K1 will de-energize. Bypass LED is on while bypass is active.

**DANGER!**

Bypass should only be implemented when the area surrounding the pressurized enclosure is known to be non-hazardous.

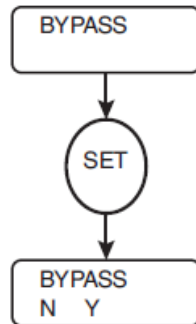

4.8. Units

The units can be changed from 'M' metric to 'I' imperial. This affects the pressure readings. "M" reads in mbar, and "I" reads in inches of water column.

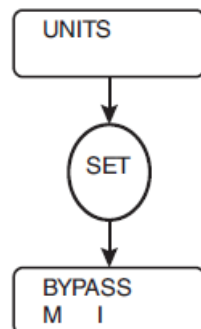

4.9. Change Password

To change the existing password, use the UP and DOWN buttons for each digit.

Enter 4 digits.

To cancel without saving a new password, press RESET. The existing password will still be valid.



Note

There is no confirmation of key strokes when changing the password. Note what the new password is when changing it.

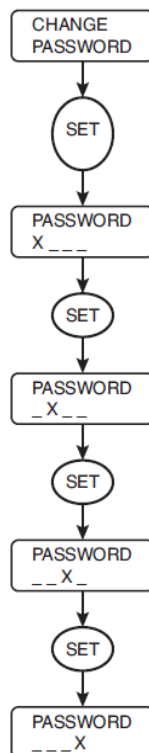

4.10. User Parameter Setting Sheet

Display	Description	User Settings
PASSWORD / SET	Password	
PURGE / PROGRAM	Program 1-5	
PURGE / TIME	Time required for purging	
ENCLOSUR / PRESS P1	Shutdown pressure P1	
ENCLOSUR / PRESS P2	Alarm/signal pressure P2	
ENCLOSUR / PRESS P3	Purge pressure P3	
ENCLOSUR / PRESS P4	Maximum pressure P4	
LEAKAGE / HYST	Leakage compensation and hysteresis	
PROGRAM / K2	User-configured K2 program	
SHUT-OFF / DELAY	Shutdown timer for K1	
BYPASS / N / Y	Bypass	
UNITS / M I	M for metric units I for imperial units	
CHANGE PASSWORD	Change password	
RESTORE DEFAULTS	Factory restore	
DISPLAY ROTATION	Landscape or portrait	
CYCLE POWER	Cycle power	

5. Product Identification

5.1. Specific Conditions of Use

- The main control unit and optional accessories are the only parts that have been evaluated for the certifications of the system.
- For dust environments, the lens of the Control Unit may pose an electrostatic discharge hazard. Use only a water-damp cloth and allow to air dry for cleaning device. Do not use or install in high charge areas. See IEC 60079-32-1 for further information.
- When the Control Unit and Vent are mounted to equipment intended to be protected by concept of protection 'p', the complete installation and assembly of parts shall be evaluated to the appropriate standards and regulations applicable for the final installation location.
- The Control Unit has a temperature class (T6 / 60 °C, T5 / T75 °C or T4 / T80 °C) that is dependent on ambient temperature. This temperature shall be considered when mounted to, or inside of, an enclosure.
- All un-used entry points to the Control Unit shall be closed with a properly certified ATEX device suitable for the area of installation with the necessary ingress protection.
- The bypass function shall be enabled only when the area is known to be non-hazardous.
- In a hazardous dust environment, regularly remove dust from the unit to prevent excessive temperature rise. See certificate for full information.
- For accessory solenoid valve 0515 and 1215 Series, a maximum permissible ripple of 20% is valid for all magnets of direct-current design.
- For all accessory solenoid valves, refer to the solenoid coil's label for ambient temperature rating, which may differ from the control unit's ratings.

5.2. Applied Standards



Note

See the certificates and/or the Declaration of Conformity for details on specific editions of the standards listed below.

IECEX and ATEX:

IEC/EN 60079-0

IEC/EN 60079-2

IEC/EN 60079-7

IEC/EN 60079-15

IEC/EN 60079-18

IEC/EN 60079-31

Purge control for use in hazardous (classified) areas, in accordance with

NFPA 496

ANSI/UL 60079-2

CAN/CSA C22.2 No. 60079-2

5.3. Type Codes

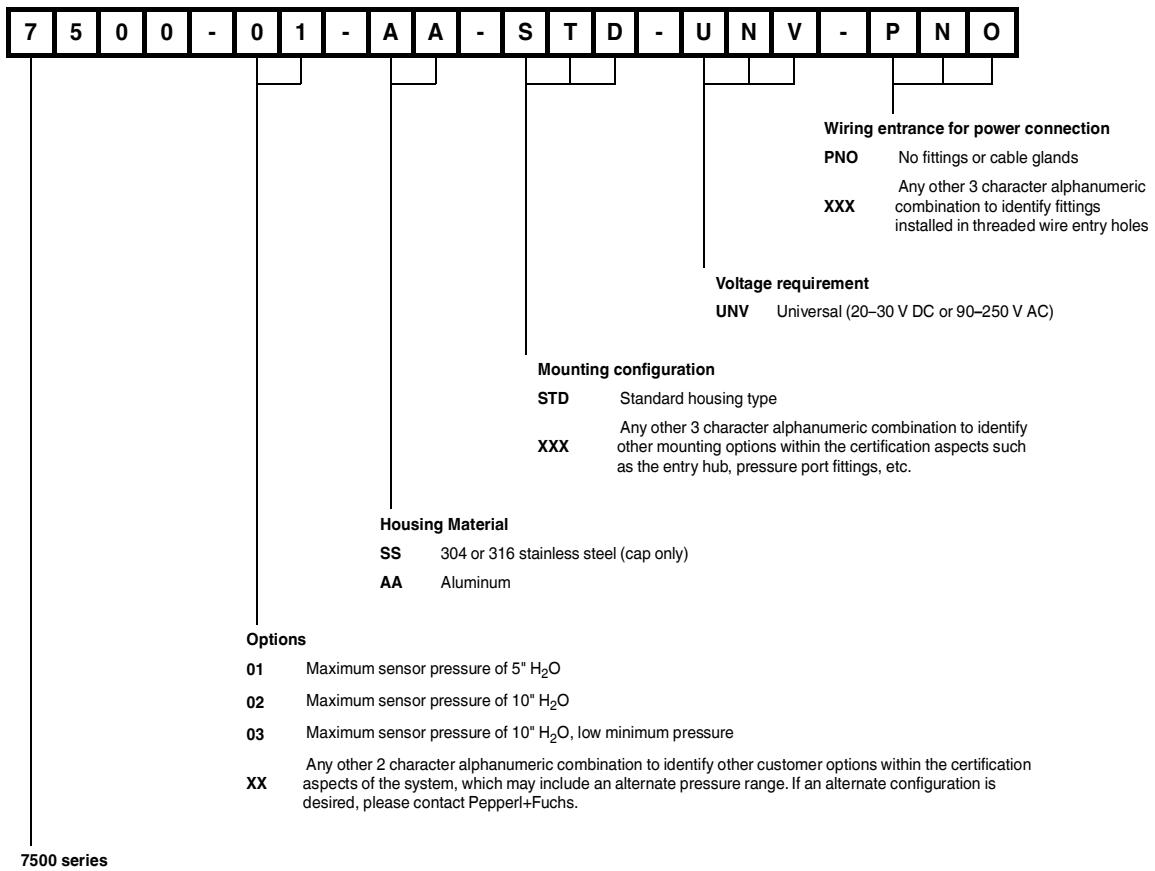

7500-MTD-* Panel/External Mount System

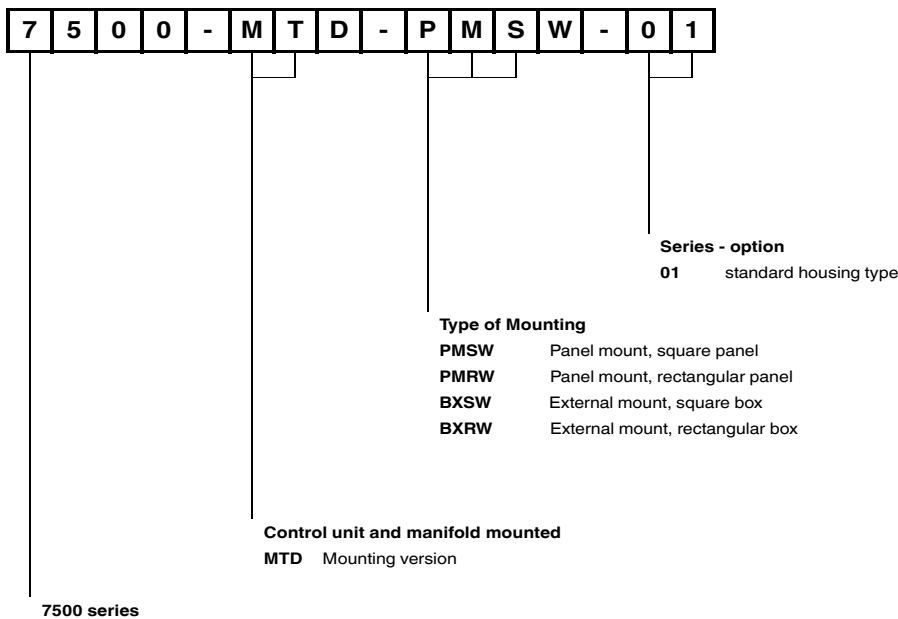

EPV-7500 Vents

E P V - 7 5 0 0 - A A - 0 1

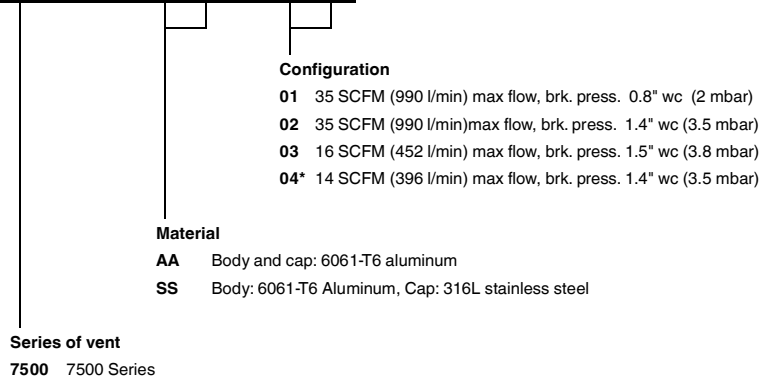

* The only possible combination with these options is "EPV-7500-AA-04"

7500-MAN-MV-01 Manifold

7 5 0 0 - M A N - M V - 0 1

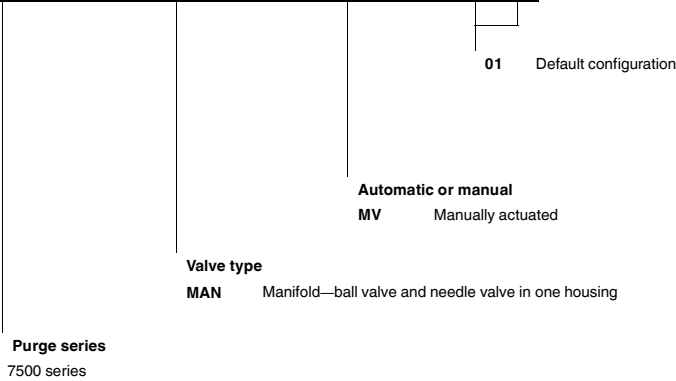

5500 Series Manifold

5 5 0 0 - M A N - E X 0 1 - 2 4 V D C

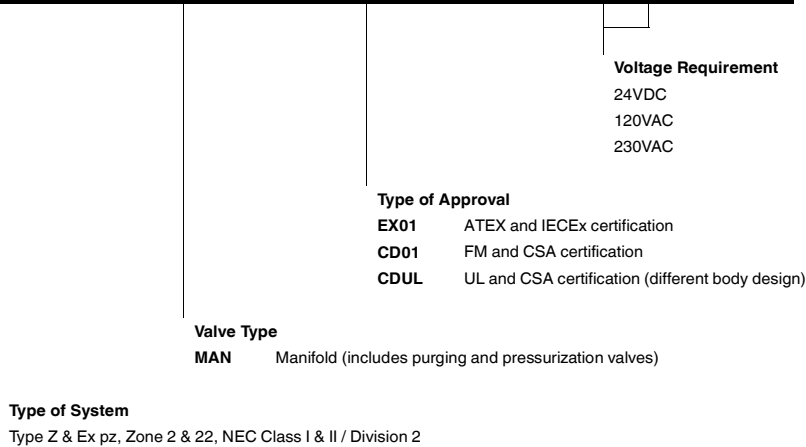

7500-MAN Automatic Manifolds

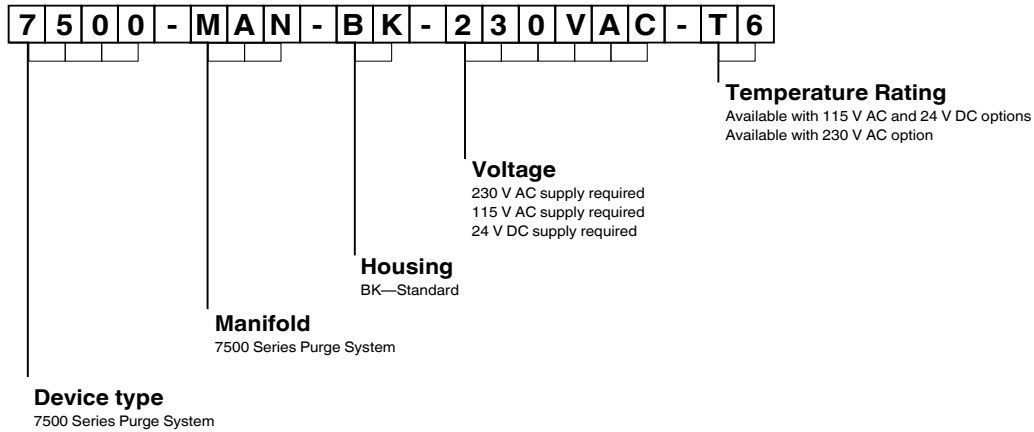

5.4. Markings (Labelling)

Control Unit

PEPPERL+FUCHS
68307 Mannheim, Germany / www.pepperl-fuchs.com

Model: 7500-01-AA-STD-UNV-PNO

Type Z / Ex pzc

 CLASSIFIED
 C UL US
 4S11

CL I/II, Div 2, Grp A-D, F-G T6...T4
 AEx ec nC [pzc Gc] IIC T6...T4 Gc
 AEx tc [pzc Dc] IIIC T60°C...T80°C Dc
 Ex ec nC [pzc Gc] IIC T6...T4 Gc
 Ex tc [pzc Dc] IIIC T60°C...T80°C Dc
 UL E184741

 CE

DEMKO 18 ATEX 2025X
 II 3 G Ex ec mc nC [pzc Gc] IIC T6...T4 Gc
 II 3 D Ex mc tc [pzc Dc] IIIC T60°C...T80°C Dc

 Ex

IECEX UL 18.0022X
 Ex ec mc nC [pzc Gc] IIC T6...T4 Gc
 Ex mc tc [pzc Dc] IIIC T60°C...T80°C Dc

 UK
 CA

Type 4X / IP66 -40°C ≤ Ta ≤ 70°C

Supply: 20-30V⁼⁼ / 0.1A, 90 to 250V[~] / 0.04A, 50-60 Hz

PURGE CONTROL FOR USE IN HAZARDOUS LOCATIONS IN ACCORDANCE WITH THE NATIONAL FIRE PROTECTION ASSOCIATION STANDARD FOR PURGED AND PRESSURIZED ENCLOSURES FOR ELECTRICAL EQUIPMENT NFPA 496:2017.

 WARNING - DO NOT OPEN WHEN AN EXPLOSION ATMOSPHERE IS PRESENT
 WARNING - POTENTIAL ELECTROSTATIC CHARGING HAZARD - SEE INSTRUCTIONS
 AVERTISSEMENT - NE PAS OUVRIR EN PRÉSENCE D'UNE ATMOSPHÈRE EXPLOSIVE
 AVERTISSEMENT-POTENTIEL ELECTROSTATIQUE CHARGE DANGEROUS LES INSTRUCTIONS

 See manual for additional ratings, warnings, and information.



ASSEMBLED IN USA 09
BEBCO EPS,

Control Unit and Manual Manifold, 7500-MTD-...

PEPPERL+FUCHS
68307 Mannheim, Germany / www.pepperl-fuchs.com

Model: 7500-MTD-BXRW-01
Type Z / Ex pzc

 **UL file E184741**
-40°C ≤ Ta ≤ 70°C

  II 3G II 3D 

Part of UL/DEMKO 18ATEX2025X
Part of IECEx UL 18.0022X



This device is part of UL classified
Type 7500 Purge System

ASSEMBLED IN USA 09 BEBCO EPS®

PEPPERL+FUCHS
68307 Mannheim, Germany / www.pepperl-fuchs.com

Model: 7500-MTD-PMSW-01
Type Z / Ex pzc

 **UL file E184741**
Type 4X
-40°C ≤ Ta ≤ 70°C

  II 3G II 3D 

Part of UL/DEMKO 18ATEX2025X
Part of IECEx UL 18.0022X

This device is part of UL classified
Type 7500 Purge System



ASSEMBLED IN USA 09 BEBCO EPS®

EPV-7500 Vent

PEPPERL+FUCHS
68307 Mannheim, Germany / www.pepperl-fuchs.com

Model EPV-7500-AA-01
Type Z / Ex[pzc]

 **UL E184741**
-40°C ≤ Ta ≤ 70°C

  II 3G II 3D 

Part of DEMKO 18ATEX2025X
Part of IECEx UL 18.0022X



This device is part of UL Classified
Type 7500 Purge System

ASSEMBLED IN USA 09 BEBCO EPS®

PEPPERL+FUCHS
68307 Mannheim, Germany / www.pepperl-fuchs.com

Model EPV-7500-AA-03
Type Z / Ex[pzc]

 **UL E184741**
Type 4X
-40°C ≤ Ta ≤ 70°C

  II 3G II 3D 

Part of DEMKO 18ATEX2025X
Part of IECEx UL 18.0022X

This device is part of UL Classified
Type 7500 Purge System

ASSEMBLED IN USA 09 BEBCO EPS®

6. Product Lifetime Care

6.1. Maintenance and Repair

Do not remove the window from the 7500-01-... control unit. If the window is damaged or removed, the control unit cannot be repaired. A new unit is required.

Do not remove the accessory conduit hub extension, 7500-HUB-AA-01, from the 7500-01-... control unit. If the conduit hub is damaged or removed, the conduit hub cannot be reinstalled. A new conduit hub is required. The conduit hub is an accessory and is not included with the 7500-01-... control unit.

The only special maintenance required on the 7500 system is cleaning of the pneumatic filters on the overall installation, when used, and periodic function checks. This includes pressure readings within the specifications contained in this manual. When checking pressure measurements of the 7500 control unit, use calibrated equipment to determine the measurements, or contact a Pepperl+Fuchs representative or the factory to send the device back for function verification.



WARNING!

No portions of the 7500 system are user-serviceable.



WARNING!

When operating the 7500 system in conjunction with a hazardous area, do not modify the system. If there is a defect, the product may need to be replaced. Repairs can only be performed by a Pepperl+Fuchs specialist who is trained and authorized to repair the defect.



WARNING!

When servicing, installing, and commissioning, the area must be free of all combustible material and/or hazardous explosive gas. Only the terminal compartment of the control unit is accessible to users. Under no circumstances shall the control unit or vent be dismantled or removed from the supplied enclosure, unless instructed in this manual.

Contact Pepperl+Fuchs customer service for an RMA (Return Merchandise Authorization).

6.2. Dismantling and Decommissioning

Abide by all local and any other code requirements for disposing of electronic equipment.

When disposing of any component of the 7500 system, "VOID" must be marked across all certification labels.

6.3. Troubleshooting

Problem	Possible Cause	Solution
Purge cycle does not start	No air to system	Check air supply; make sure minimum pressure is available
	Minimum enclosure pressure not high enough	Check vent and enclosure seals; check compensation valve setting
	Control unit in dust mode	Program 5 was used instead of one of the Programs 1-4. Select proper program.

Your automation, our passion.

Explosion Protection

- Intrinsic Safety Barriers
- Signal Conditioners
- FieldConnex® Fieldbus
- Remote I/O Systems
- Electrical Ex Equipment
- Purge and Pressurization
- Industrial HMI
- Mobile Computing and Communications
- HART Interface Solutions
- Surge Protection
- Wireless Solutions
- Level Measurement

Industrial Sensors

- Proximity Sensors
- Photoelectric Sensors
- Industrial Vision
- Ultrasonic Sensors
- Rotary Encoders
- Positioning Systems
- Inclination and Acceleration Sensors
- Fieldbus Modules
- AS-Interface
- Identification Systems
- Displays and Signal Processing
- Connectivity

Pepperl+Fuchs Quality

Download our latest policy here:

www.pepperl-fuchs.com/quality

