

# 6100 Purge System User Manual

Bebco EPS® 6100 Series

Ex pxb Purge and Pressurization System



Your automation, our passion.

 **PEPPERL+FUCHS**

---

With regard to the supply of products, the current issue of the following document is applicable:  
The General Terms of Delivery for Products and Services of the Electrical Industry, published by the  
Central Association of the Electrical Industry (Zentralverband Elektrotechnik und Elektroindustrie  
(ZVEI) e.V.) in its most recent version as well as the supplementary clause: "Expanded reservation of  
proprietorship".

### **Worldwide**

Pepperl+Fuchs Group  
Lilienthalstr. 200  
68307 Mannheim  
Germany

Phone: +49 621 776 - 0  
E-mail: [info@de.pepperl-fuchs.com](mailto:info@de.pepperl-fuchs.com)

### **North American Headquarters**

Pepperl+Fuchs Inc.  
1600 Enterprise Parkway  
Twinsburg, Ohio 44087  
USA

Phone: +1 330 425-3555  
E-mail: [sales@us.pepperl-fuchs.com](mailto:sales@us.pepperl-fuchs.com)

### **Asia Headquarters**

Pepperl+Fuchs Pte. Ltd.  
P+F Building  
18 Ayer Rajah Crescent  
Singapore 139942

Phone: +65 6779-9091  
E-mail: [sales@sg.pepperl-fuchs.com](mailto:sales@sg.pepperl-fuchs.com)  
<https://www.pepperl-fuchs.com>

# Table of contents

<b>1. Introduction.....</b>	<b>5</b>
1.1. Content of this Document .....	5
1.2. Target Group, Personnel.....	6
1.3. Symbols Used.....	7
1.4. Pertinent Laws, Standards, Directives, and Further Documentation.....	8
1.5. Declaration of Conformity.....	8
<b>2. Product Description .....</b>	<b>9</b>
2.1. Introduction.....	9
2.2. 6100 System Overview .....	9
2.2.1 6100-MP-EX-* Control Unit (with regulator).....	11
2.2.2 6100-MP-EX-* Control Unit (no regulator) .....	12
2.3. Control Unit.....	13
2.3.1 Technical Data.....	13
2.3.2 Dimensions: 6100-MP-EX-* .....	16
2.3.3 Mounting: 6100-MP-EX-* .....	17
2.3.4 Dimensions: Remote-Mount UIC.....	17
2.3.5 Mounting: Remote-Mount UIC.....	18
2.4. 6100-MP-LPP-* Pressure Sensor .....	18
2.4.1 Technical Data.....	18
2.4.2 Dimensions .....	20
2.4.3 Mounting .....	20
2.5. EPV-6100-MP-XX Vent.....	21
2.5.1 Technical Data.....	21
2.5.2 Dimensions .....	22
2.5.3 Cutout dimensions .....	23
2.5.4 Mounting the EPV .....	23
2.6. 6000-TEMP-01 Temperature Hub.....	24
2.6.1 Technical Data.....	24
2.7. 6000-TSEN-01 Temperature sensor .....	25
2.7.1 Technical Data.....	25
<b>3. Installation and Operation.....</b>	<b>26</b>
3.1. Electrical Installation .....	26

3.1.1	General wiring notes .....	26
3.1.2	Wiring parameters .....	26
3.1.3	Power and intrinsically safe wiring .....	27
3.2.	Pneumatic requirements .....	28
3.2.1	Protective gas supply .....	28
3.2.2	Pneumatic Connections .....	29
3.2.3	Pressurization Adjustments .....	29
3.2.4	Purging Adjustment .....	29
3.3.	Operation .....	30
3.3.1	Turning on Power to the Enclosure .....	30
3.3.2	Turning off Power to the Enclosure .....	31
3.3.3	6100 Series System Components .....	32
3.3.4	Requirements for Purging/Pressurizaion .....	33
3.3.5	Setup Procedures .....	37
3.3.6	Operation in Gas-Hazardous Locations .....	39
<b>4.</b>	<b>Programming .....</b>	<b>40</b>
4.1.	User Interface .....	40
4.1.1	Programming Menu.....	41
4.1.2	Purge Settings.....	42
4.1.3	Units.....	42
4.1.4	Inputs .....	42
4.1.5	Outputs .....	45
4.1.6	Password.....	46
4.1.7	Language .....	46
4.1.8	Bypass Control.....	46
4.1.9	Restore Defaults.....	46
4.1.10	Stats.....	46
4.1.11	Statistics.....	47
4.1.12	Alarm.....	50
4.1.13	Fault .....	51
4.1.14	Clear Statistics .....	51
4.1.15	Clear Fault.....	51
4.2.	Programming Worksheet.....	52
<b>5.</b>	<b>Product Identification .....</b>	<b>58</b>

---

5.1. Specific Conditions of Use .....	58
5.2. Applied Standards and Markings .....	59
5.3. Type Codes .....	59
5.4. Labels and Markings .....	61
<b>6. Product Lifetime Care .....</b>	<b>62</b>
6.1. Maintenance and Repair .....	62
6.2. Troubleshooting Alarms and Fault Conditions .....	63
6.3. Dismantling and Decommissioning .....	64

# 1. Introduction

## 1.1. Content of this Document

Knowledge of the basic safety regulations and additional training and experience in the area of explosion protection are essential for the safe handling and failure-free operation of the 6100 series purge and pressurization system. These operating instructions contain important data and information to ensure the safe use of the 6100 system in hazardous areas and to meet the requirements of Directive 2014/34/EU. This manual, particularly the safety information, must be followed by all personnel who work on the system.

This document contains information that you need to use your product throughout the applicable stages of the product life cycle. These can include the following:

- Product identification
- Delivery, transport, and storage
- Mounting and installation
- Commissioning and operation
- Maintenance and repair
- Troubleshooting
- Dismounting and disposal



### WARNING!

---

Failure to follow these instructions may impair the safety protection and function of the equipment.

---



### Note

---

For complete information on this product, see further documentation at [www.pepperl-fuchs.com](http://www.pepperl-fuchs.com).

Information about individual components can be provided on request.

---

The documentation comprises the following parts:

- This document
- Safety instruction manual
- Datasheet

In addition, the documentation may comprise the following parts, if applicable:

- Manufacturer declaration of conformity
- EU declaration of conformity
- Certificates
- Additional documents

## 1.2. Target Group, Personnel

Responsibility for planning, assembly, commissioning, operation, maintenance, and dismantling lies with the plant operator. In accordance with but not limited to IEC/EN 60079-14, only appropriately trained and qualified personnel may carry out mounting, installation, commissioning, operation, maintenance, and dismantling of the product. National laws and regulations must be observed and take precedence over any aspects of IEC/EN 60079-14. The personnel must have read and understood the instruction manual and any further documentation.

The operator and/or installer undertake to ensure that only specialist, trained personnel work on the 6100 series purge and pressurization system and that they:

- are familiar with the occupational safety and accident prevention regulations and have been briefed regarding handling of the unit.
- have the additional knowledge of explosion protection that is required for work on explosion-protected components.
- are familiar with the relevant rules and regulations for the installation, operation, and maintenance of explosion-protected systems.
- have read the safety section and warnings in this manual.

## 1.3. Symbols Used

This document contains symbols to identify warning messages and information messages.

### Warnings

You will always find warning messages whenever hazards could result from your actions. It is essential that you observe these warning messages to ensure your personal safety and to prevent property damage.

Warning messages are shown in descending order according to the risk level, as follows:



#### **DANGER!**

---

This symbol warns you of an immediate and present danger.

If you do not observe this warning message, there is a risk of personal injury and even death.

---



#### **WARNING!**

---

This symbol warns you of a potential fault or hazard.

If you do not observe this warning message, there is a risk of personal injury or severe property damage.

---



#### **CAUTION!**

---

This symbol warns you of a potential fault.

Failure to observe this warning message may result in the malfunctioning or complete failure of the product or any systems and plants connected to it.

---

### Information Symbols and Messages



#### **Note**

---

This symbol draws your attention to important information.

---



#### **Action instructions**

---

This symbol highlights an action. You are prompted to perform an action or sequence of actions.



## 1.4. Pertinent Laws, Standards, Directives, and Further Documentation

NEC, CEC, and other national and local laws, standards, or Directives that are applicable to the intended use and installation location must be observed. In relation to hazardous areas, Directive 1999/92/EC must be observed.

The corresponding datasheets, EU Declaration of Conformity, EU Type Examination Certificates, NEC/NFPA and CEC certificates, and control drawings, if applicable (see datasheet), are an integral part of this document. You can find this information at [www.pepperl-fuchs.com](http://www.pepperl-fuchs.com).

Due to constant revisions, documentation is always subject to change. Please refer only to the most up-to-date version, which can be found at [www.pepperl-fuchs.com](http://www.pepperl-fuchs.com).

## 1.5. Declaration of Conformity

All products were developed and manufactured under observance of the applicable European standards and guidelines.

**i**

### Note

A Declaration of Conformity is included with these instructions and can be requested from the manufacturer or obtained online at [www.pepperl-fuchs.com](http://www.pepperl-fuchs.com). Additional documentation can also be provided for individual components.

The product manufacturer, the Pepperl+Fuchs Group, 68307 Mannheim, has a certified quality assurance system that conforms to ISO 9001.



ISO9001

## 2. Product Description

### 2.1. Introduction

The pressurized enclosure is one of the most multifunctional applicable types of protection. It is based on a purge operation that removes potential ignitable gas mixtures of the local environment from the enclosure. After the purge, the overpressure will be maintained by adding as much pressurized air as necessary to compensate for the leaks of the enclosure or components. This constant state of overpressure protects against the diffusion of potentially explosive atmospheres.

During normal operation (motor running) the vent plunger will be closed and the internal pressure will be lower than the breaking pressure of the vent used. At the start of the purge phase, the internal pressure of the enclosure will increase above the breaking pressure of the vent. After the plunger opens during the purge phase, the internal pressure drops, depending on the vent's flow requirements. See Purge Pressure and Flow Rate Table.

Hot spots at single components inside the enclosure are monitored by temperature sensors (optional) and if required turned off. This reduces the risk that no unacceptable surface temperature will occur. For this reason, the pressurized enclosure is especially suited for the use of non-Ex certified equipment in Ex areas.

Enclosure has to be prepared specially for the use of Ex p:

- All walls have to be additionally armed
- The doors have to be specially constructed
- Tested for mechanical stability
- Tested for overpressure resistance



#### **DANGER!**

---

When using an inert gas like nitrogen, an asphyxiation hazard can exist.

---

### 2.2. 6100 System Overview

The purpose of the Pepperl+Fuchs Bebcos EPS 6100 series Ex pxb, Zone 1 motor purge and pressurization system is to allow general purpose or non-rated electrical equipment located in a general purpose enclosure to operate in Zone 1 locations. Other purposes of the 6100 series system include heat, moisture, and dust contamination prevention.

The 6100 series system operates by controlling and monitoring compressed instrument air or inert gas through the protected enclosure/motor so as to remove and prevent the accumulation of flammable gas. The system consists of the following parts:

- The 6100-MP-EX-\* control unit houses the controller and the pneumatics for purging/pressurization and monitors these actions.
- The 6100-MP-LPP-01 pressure sensor is usually mounted at the lowest pressure section of the motor and feeds back the pressure to the controller. This pressure will determine if the enclosure is operating at a safe pressure and will indicate the enclosure/motor pressure through the controller's user-interface controller (UIC).
- The EPV-6100-MP-\* enclosure protection vent purges and maintains pressure within the enclosure/motor. There is a pressure switch that detects orifice pressure/flow back to the controller, which indicates if the correct flow is measured for purging. There are several vent options for different flow rates.
- The optional 6000-TEMP-01 temperature hub and 6000-TSEN-01 temperature sensor are used to monitor temperatures within the enclosure/motor. This signal runs back to the controller and can be used to start the purging valve for cooling or take action through various means.

The controller's UIC allows programming of up to 3 switch inputs, temperature modules, enclosure power contacts, 2 auxiliary outputs, and various user-configured functions. Through the user-interface menus, configuration of the system for purge time, flow rates, monitoring and shut-off pressures, and enclosure size are easily programmed for a fully automated system. Additional features allow inputs for system bypass, enclosure power on/off, temperature monitoring for activation of the purging valve for cooling or auxiliary relay for separated cooling or alarm, delay power shutdown, and more. The auxiliary outputs can be configured to activate on input switch status, or any alarm states of pressure, flow, and temperature.

The 6100 system uses many components of the Pepperl+Fuchs Bebcos EPS 6000 series purge and pressurization system and can provide a complete system for purging and pressurizing motors for hazardous location operation.



## Note

One operations copy of this manual must be studied and retained by the system operator in addition to one permanent file copy. Users' agents are responsible for transferring this manual to the user/operator prior to startup.

## 2.2.1 6100-MP-EX-\* Control Unit (with regulator)

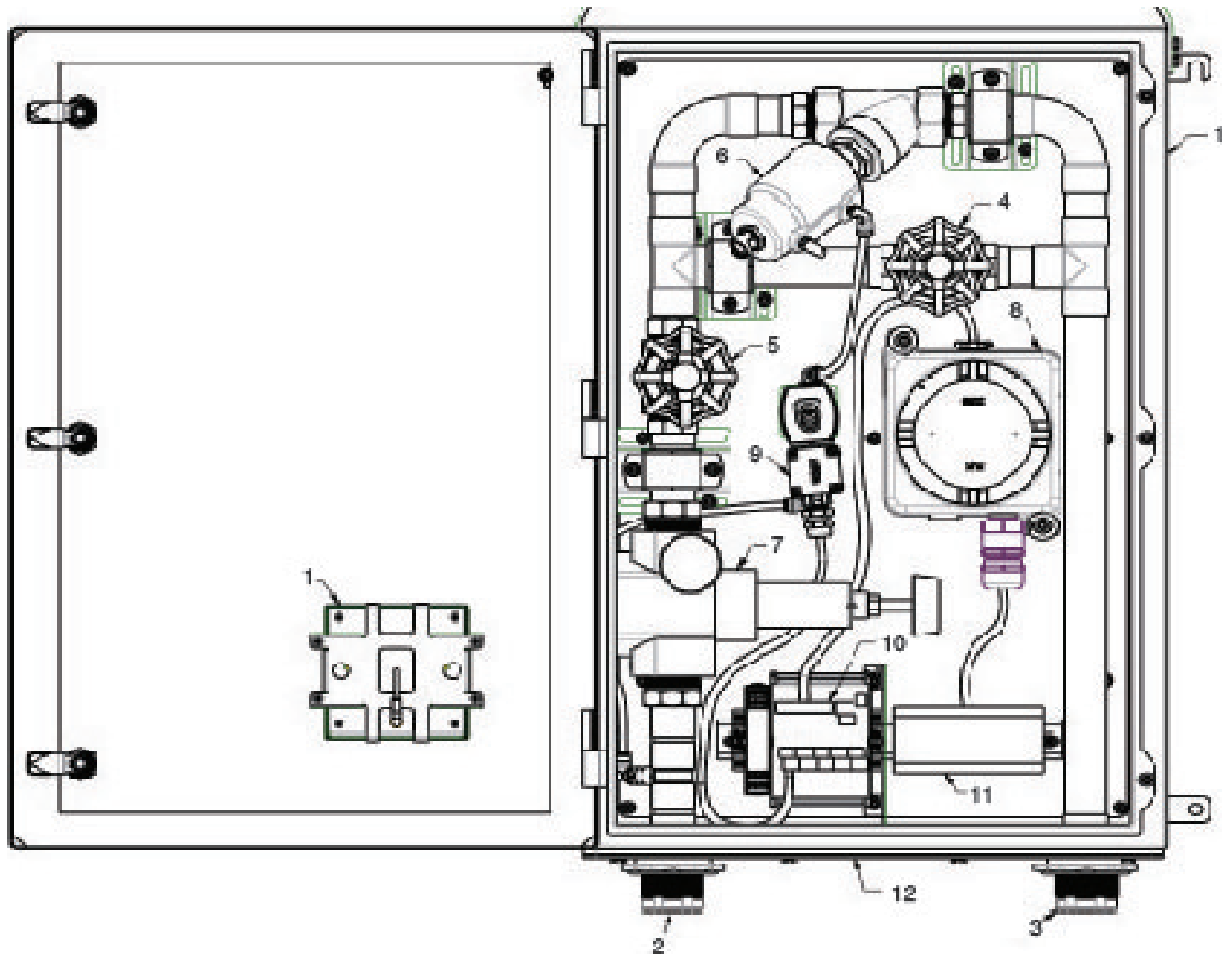

### Control Unit (With Regulator)

- 1 User-Interface Controller (UIC)\*
- 2 Inlet for purge gas supply—1¼" FNPT
- 3 Outlet for purge gas supply into enclosure—1¼" FNPT
- 4 Manual gate valve for pressurization
- 5 Manual gate valve for regulation
- 6 Angle seat valve
- 7 Regulator for purge gas supply
- 8 Enclosure Protection Control Unit (EPCU)
- 9 Intrinsically safe pilot valve for actuation of purging valve
- 10 Intrinsically safe termination board
- 11 Power terminals
- 12 Gland plate for cable glands
- 13 6100-MP-EX-\* control unit

**\*User-Interface Controller (UIC):** For models designated 6100-MP-EX-XX-02-XXX, the UIC is mounted remotely, not as shown in this diagram. In that situation, the opening in the cabinet door is covered with a square panel.

## 2.2.2 6100-MP-EX-\* Control Unit (no regulator)

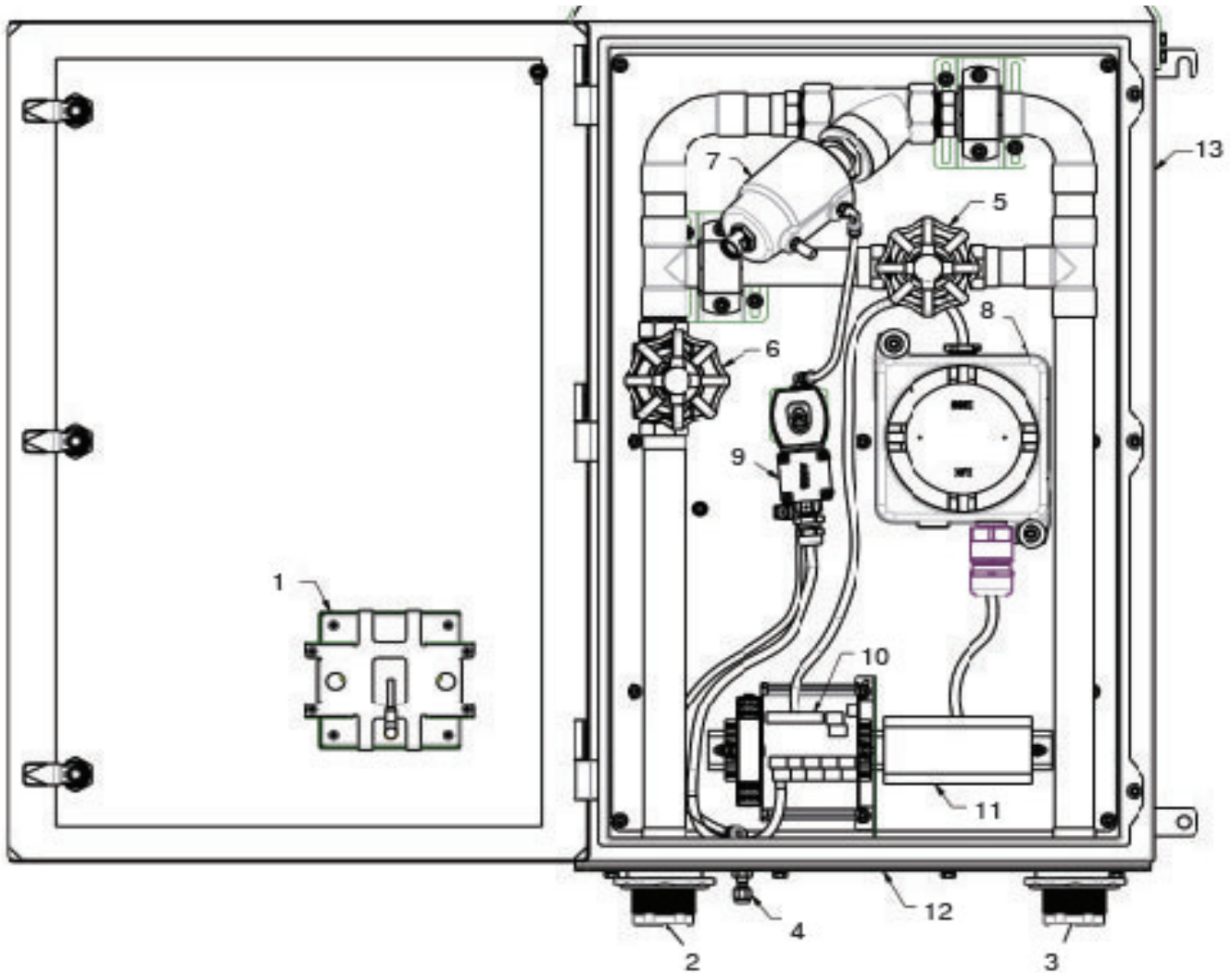

### Control Unit (No Regulator)

- 1 User-Interface Controller (UIC)\*
- 2 Inlet for purge gas supply—1¼" FNPT
- 3 Outlet for purge gas supply into enclosure—1¼" FNPT
- 4 I. S. pilot valve supply port 1/4" tube compression fitting
- 5 Manual gate valve for pressurization
- 6 Manual gate valve for regulation
- 7 Angle seat valve
- 8 Enclosure Protection Control Unit (EPCU)
- 9 Intrinsically safe pilot valve for actuation of purging valve
- 10 Intrinsically safe termination board
- 11 Power terminals
- 12 Gland plate for cable glands
- 13 6100-MP-EX-\* control unit

\***User-Interface Controller (UIC):** For models designated 6100-MP-EX-XX-02-XXX, the UIC is mounted remotely, not as shown in this diagram. In that situation, the opening in the cabinet door is covered with a square panel.

## 2.3. Control Unit

### 2.3.1 Technical Data

Item	Value
<b>General specifications</b>	
Operating mode	manual, semi-automatic, or fully automatic (programmable)
Series	6100 Series
Number of volume exchanges	4 to 19
Hazardous environment	Gas
<b>Supply</b>	
Rated voltage $U_r$	100 ... 250 V AC; 50 ... 60 Hz / 0.2 A 20 ... 30 V DC; 0.6 A Overvoltage category II
<b>Electrical specifications</b>	
Connection	
Power	Ex e terminal blocks
Connection	6000-ISB DIN-mounted terminal
<b>Input</b>	
Input type	<b>IS 1:</b> Dedicated for 6000-TEMP-01 (optional) <b>IS 2:</b> Dedicated for 6100-MP-LPP <b>Input 1:</b> SRM, discrete input, intrinsically safe <b>Input 2:</b> SRM, discrete input, intrinsically safe <b>Input 3:</b> Dedicated for EPV-6100-MP; flow signal <b>Input 4:</b> Dedicated high pressure switch, max pressure signal (optional)
<b>Output</b>	
Output I	AUX 1
Output type	Dry contacts; SPDT
Inrush current	5 A
Contact loading	2 A at 240 V AC resistive load 2 A at 24 V DC
Output II	AUX 2
Output type	Dry contacts; SPDT
Inrush current	5 A
Contact loading	2 A at 240 V AC resistive load 2 A at 24 V DC
Output III	Enclosure 1 and 2
Output type	Dry contacts (2); SPDT, NO
Inrush current	72 A

**\*Warning:** Inputs 1, 2, 3, and 4 must be used with the SRM-6000 for tested EMC immunity.

Contact loading	8 A at 240 V AC / 120 V AC resistive load 8 A at 24 V DC
<b>Indicators/settings</b>	
LED indication	Safe pressure: Blue—safe pressure is achieved Enclosure power: Green—power on Red—power off Rapid exchange: Blue—purging is running System bypass: Yellow—bypass is activated Alarm fault: Red (blinking)—any alarm input detected Red (solid)—fault
<b>Pneumatic parameters</b>	
Protective gas supply	Clean, regulated air or inert gas
Pressure requirement	regulated side: 1.4 ... 8.3 bar (20 ... 120 psig) unregulated side: 4.1 ... 8.3 bar (65 ... 120 psig)
Safe pressure	0.625 mbar (0.25 in wc) minimum for 6100-MP-LPP-*
Purge flow and enclosure pressure rate	2000 l/m ... 14000 l/m see EPV-6100 datasheet for flow rate steps
Valve flows	pressurization valve: manual gate valve purging valve: pilot drive angle seat valve pilot valve: intrinsically safe solenoid valve
<b>Directive conformity</b>	
Electromagnetic compatibility	
Directive 2014/30/EU	EN 61326-1:2013
RoHS	
Directive 2011/65/EU (RoHS)	EN IEC 63000:2018
<b>Ambient conditions</b>	
Ambient temperature	0 ... 60 °C (-32 ... 140 °F) Standard version -20 ... 60 °C (-4 ... 140 °F) Low temp version, no regulator version
Storage temperature	0 ... 80 °C (-32 ... 176 °F) Standard version -20 ... 80 °C (-4 ... 176 °F) Low temp version, no regulator version
Relative humidity	5 ... 95 %, noncondensing
Altitude	max. 2000 m
Vibration resistance	5 ... 100 Hz; 1g, all axes
Impact resistance	30g; 11 ms, all axes
<b>Mechanical specifications</b>	
Connection type	Terminals
Cable entry	3 x M16 holes, included plugs are not hazardous-location rated 4 x M20 holes, included plugs are not hazardous-location rated

Degree of protection	IP66 (Device is protected against dust and strong jets of water.)
Pollution degree	Device can be installed in environments up to pollution degree 4.
Material	inlet and outlet: 1¼ inch NPTF, 316 stainless steel internal piping: copper bulkhead fittings: 316 stainless steel (no regulator model only) gate valve: bronze, Grafoil seals purging valve: 316 stainless steel, PTFE seals solenoid valve: brass housing: 316L stainless steel regulator: zinc (standard temp); aluminum (low temp); N/A (no regulator) filter (pneumatic): aluminum tubing (pneumatic): nylon fittings (pneumatic): nickel-plated brass
Mass	47.2 kg (104 lbs)
Dimensions	216 mm x 508 mm x 770 mm (8.5" x 20" x 30.3")
<b>Torque requirements</b>	
Terminal blocks	0.5 ... 0.6 Nm
IS Board	0.5 ... 0.6 Nm
1¼" NPT Inlet/Outlet	1.5–2.5 turns past finger tight (Do not overtighten!)
Compression fitting tube end (No regulator model only)	1¼ turns past finger tight
M10 earth ground	10 Nm
M10 mounting screw	15 Nm
<b>Data for application in connection with hazardous areas</b>	
Certificate	CML 19 ATEX 1425X
Marking	 II2G Ex db eb ib [ib Gb][pxb Gb] IIC T4 Gb
Directive conformity	
Directive 2014/34/EU	EN IEC 60079-0:2018 EN 60079-1:2014 EN 60079-2:2014 EN 60079-7:2015 + A1:2018 EN 60079-11:2012
<b>International approvals</b>	
IECEx approval	IECEx CML 19.0156X Ex db eb ib [ib Gb][pxb Gb] IIC T4 Gb
<b>General information</b>	
Supplementary information	EC-Type Examination Certificate, Statement of Conformity, Declaration of Conformity, Attestation of Conformity and instructions have to be observed where applicable. For information see <a href="http://www.pepperl-fuchs.com">www.pepperl-fuchs.com</a> . Supplemental Standards : EN 61010-1:2010



## 2.3.2 Dimensions: 6100-MP-EX-\*

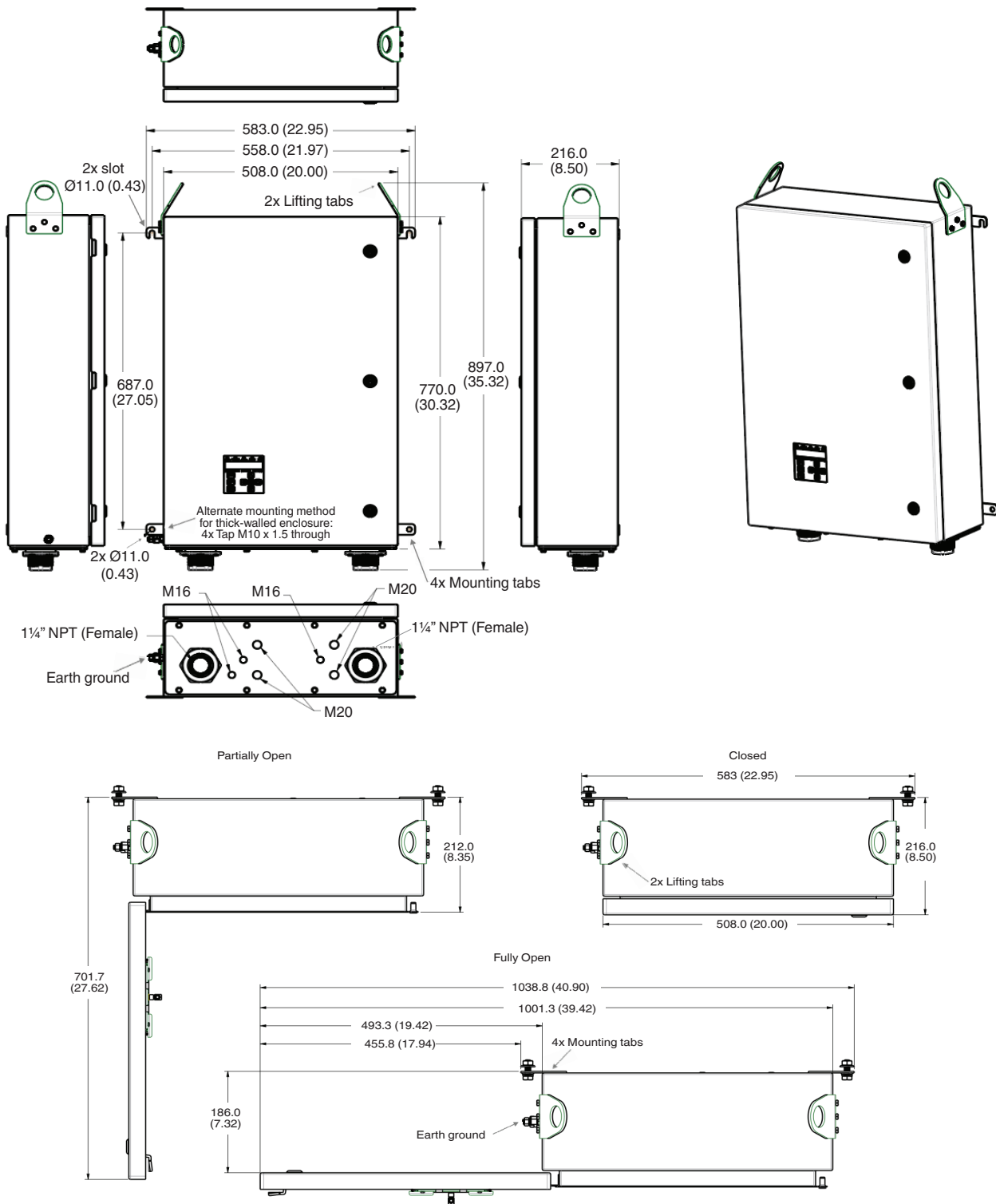

Dimensions shown in mm (in).



### Note

The purge controller is equipped with a stud for equipotential bonding.

### 2.3.3 Mounting: 6100-MP-EX-\*

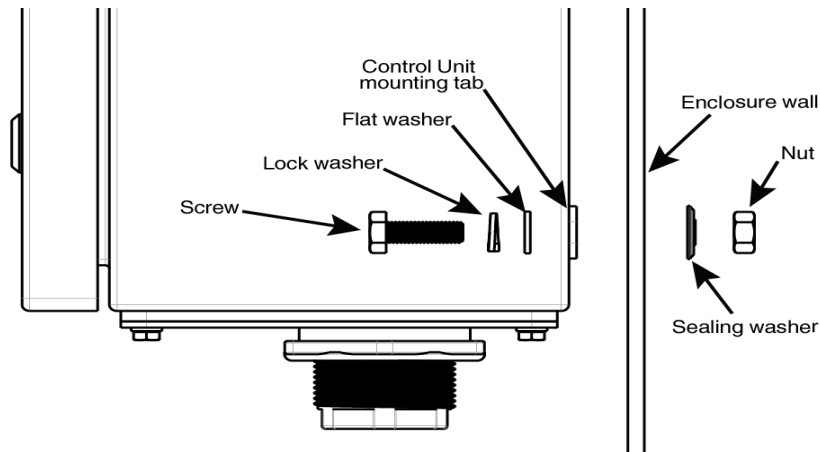

#### Note

##### Hardware included for M10 mounting holes:

Screw, lock washer, flat washer, sealing washer and nut

Sealing washer and nut are not used for mounting to thick-walled enclosure (wall thickness > 8 mm (5/16 in)).

### 2.3.4 Dimensions: Remote-Mount UIC

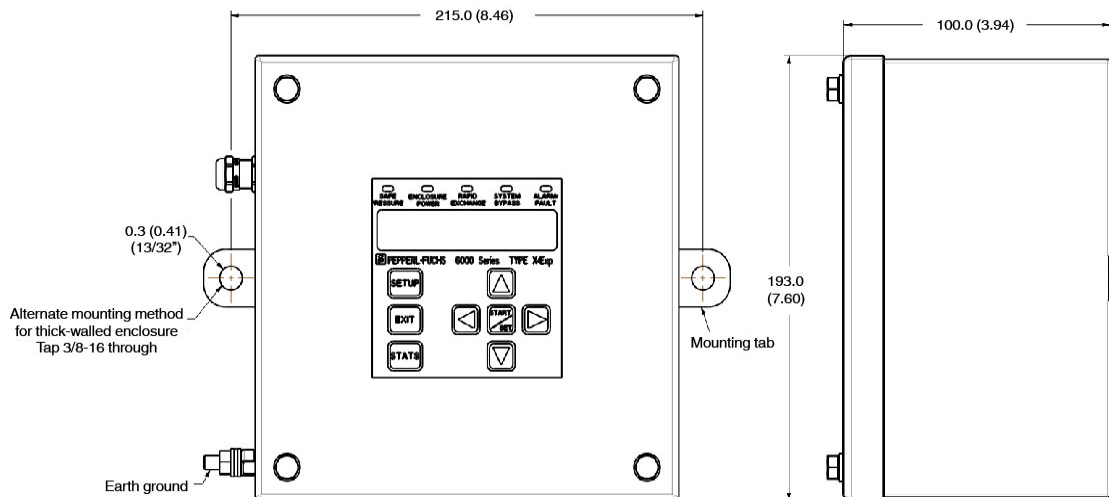

Dimensions shown in mm (in).

## 2.3.5 Mounting: Remote-Mount UIC

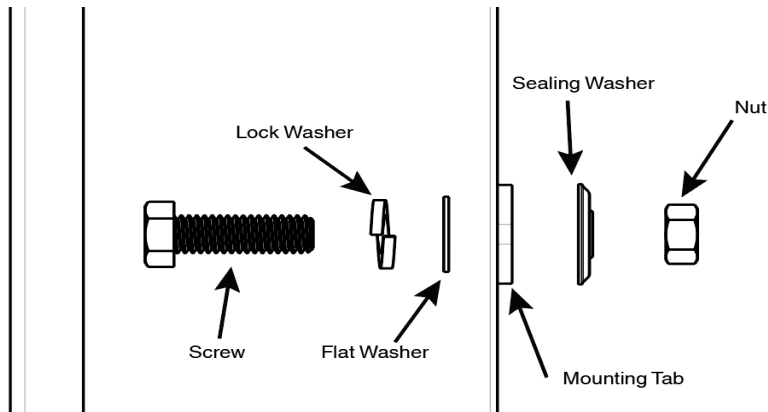

### Note

**Hardware required for 2x Ø10.3mm (0.41 in. (13/32 in.)) mounting holes:**

Screw, lock washer, flat washer, sealing washer and nut

Sealing washer and nut are not used when mounting to thick-walled enclosure (wall thickness > 8 mm (5/16 in)).

## 2.4. 6100-MP-LPP-\* Pressure Sensor

### 2.4.1 Technical Data

Item	Value
<b>General specifications</b>	
Series	6100 Series
Hazardous environment	Gas
<b>Electrical specifications</b>	
Connection	
Power	Intrinsically safe connection to the 6100 control unit
Signal	Bus to 6100 control unit
Connection	M12 connector; 4-pin, max length 30 m
<b>Indicators/settings</b>	
LED indication	power: green
<b>Pneumatic parameters</b>	
Maximum pressure	0 ... 25 mbar (0 ... 10.1 in wc) pressure range

<b>Directive conformity</b>	
Electromagnetic compatibility	
Directive 2014/30/EU	EN 61326-1:2013
RoHS	
Directive 2011/65/EU (RoHS)	EN IEC 63000:2018
<b>Ambient conditions</b>	
Ambient temperature	-20 ... 60 °C (-4 ... 140 °F)
Storage temperature	-30 ... 80 °C (-22 ... 176 °F)
Relative humidity	5 ... 95 % noncondensing
Vibration resistance	10 ... 100 Hz, 1g, 12 m <sup>2</sup> , all axes
Impact resistance	30 g, 11 ms, all axes
<b>Mechanical specifications</b>	
Material	5052 anodized aluminum, 6061T6 anodized aluminum
Installation	<ul style="list-style-type: none"> <li>Any orientation to enclosure</li> <li>Not gravity dependent</li> </ul>
Mass	Approx. 0.5 kg (1.1 lb)
Dimensions	57.2 mm x 81.1 mm x 82.6 mm (2.3" x 3.2" x 3.3")
Torque requirements	
Sealing washer & nut	0.25–1 turn past finger tight (Do not overtighten!)
Mounting	1½" NPT knockout (50.8 mm (2") hole) with sealing washer and nut
<b>Data for application in connection with hazardous areas</b>	
Certificate	CML 19 ATEX 1425X
Marking	 II 2 G Ex ib [pxb Gb] IIC T4 Gb
Directive conformity	
Directive 2014/34/EU	EN IEC 60079-0:2018 EN 60079-2:2014 EN 60079-11:2012
<b>International approvals</b>	
IECEx approval	IECEx CML 19.0156X Ex ib [pxb Gb] IIC T4 Gb
<b>General information</b>	
Supplementary information	EC-Type Examination Certificate, Statement of Conformity, Declaration of Conformity, Attestation of Conformity and instructions have to be observed where applicable. For information see <a href="http://www.pepperl-fuchs.com">www.pepperl-fuchs.com</a> . Supplemental Standards : EN 61010-1:2010

## 2.4.2 Dimensions

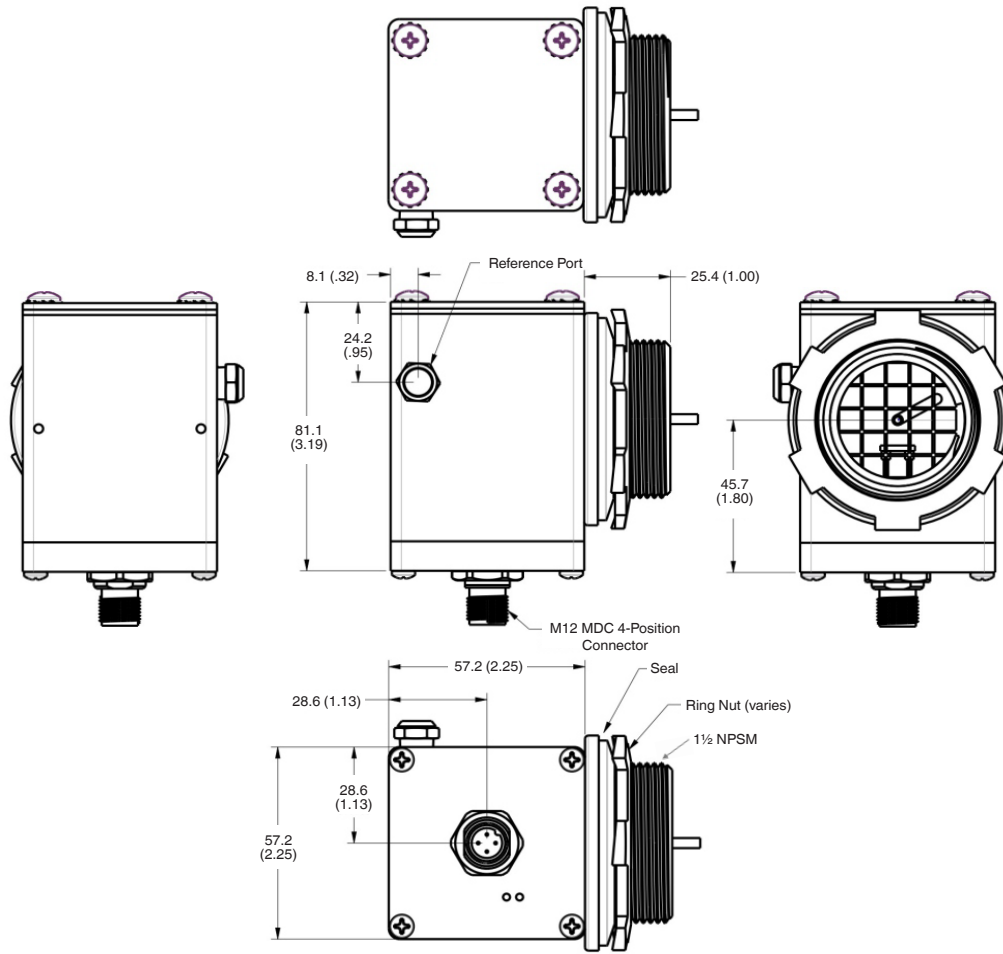

Dimensions shown in mm (in).

## 2.4.3 Mounting

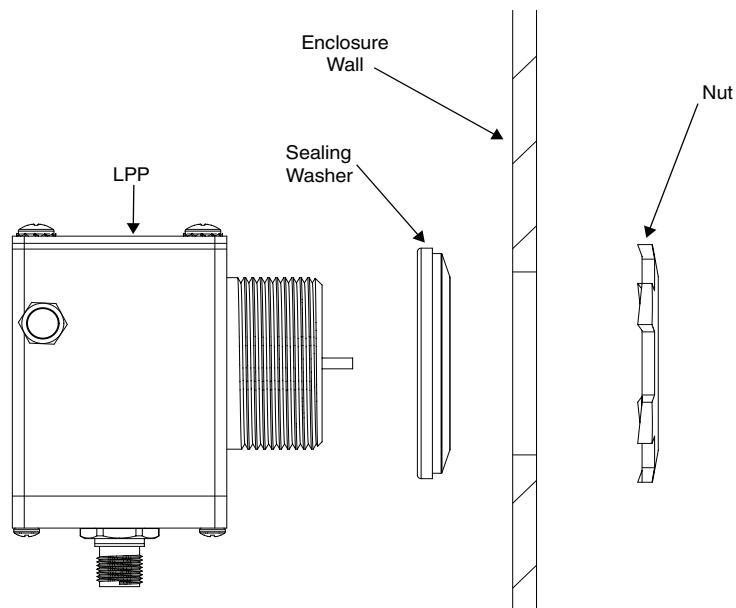

## 2.5. EPV-6100-MP-XX Vent

### 2.5.1 Technical Data

Item	Value
<b>General specifications</b>	
Series	6100 Series
Hazardous environment	Gas
<b>Electrical specifications</b>	
Connection	
Power	Intrinsically safe connection to the 6100 control unit
Signal	2-wire SRM
Connection	2-wire
<b>Pneumatic parameters</b>	
Safe pressure	0.625 mbar (0.25 in wc)
Enclosure pressure	0 ... 50 mbar (0 ... 20.1 in wc)
Purge flow rate and enclosure pressure	See "Purge Pressure & Flow Rate Table" for purge flow rate and enclosure pressure values.
Flow rate for leakage consumption	Varies depending on enclosure seal
Breaking pressure	See "Purge Pressure & Flow Rate Table" for purge flow rate and enclosure pressure values.
<b>Mechanical specifications</b>	
Material	316L stainless steel

Purge Pressure & Flow Rate Table											
Model Number		EPV-6100-MP-020-XXX		EPV-6100-MP-050-XXX		EPV-6100-MP-080-XXX		EPV-6100-MP-110-XXX		EPV-6100-MP-140-XXX	
Purge Flow, L/m		2000		5000		8000		11000		14000	
Model	BP (mbar)	Purge Pressure (mbar)	Peak Pressure of Enclosure (mbar)	Purge Pressure (mbar)	Peak Pressure of Enclosure (mbar)	Purge Pressure (mbar)	Peak Pressure of Enclosure (mbar)	Purge Pressure (mbar)	Peak Pressure of Enclosure (mbar)	Purge Pressure (mbar)	Peak Pressure of Enclosure (mbar)
EPV-6100-MP-XXX-010	10	11.6	12.5	11.9	12.5	14.8	15.5	14.2	15.0	14.0	14.5
EPV-6100-MP-XXX-025	25	30.0	36.5	32.9	35.5	25.2	32.5	25.6	30.0	23.5	30.0
EPV-6100-MP-XXX-030	30	37.3	40.0	37.3	40.0	33.1	40.0	31.9	40.0	25.3	40.0
EPV-6100-MP-XXX-040	40	42.7	47.5	43.8	47.5	35.9	47.5	28.2	47.5	25.1	47.5
EPV-6100-MP-XXX-050	50	47.3	53.0	49.6	53.0	41.9	53.0	30.8	53.0	28.6	53.0

Note: Breaking and purge pressures shown above are approximate values.

## 2.5.2 Dimensions

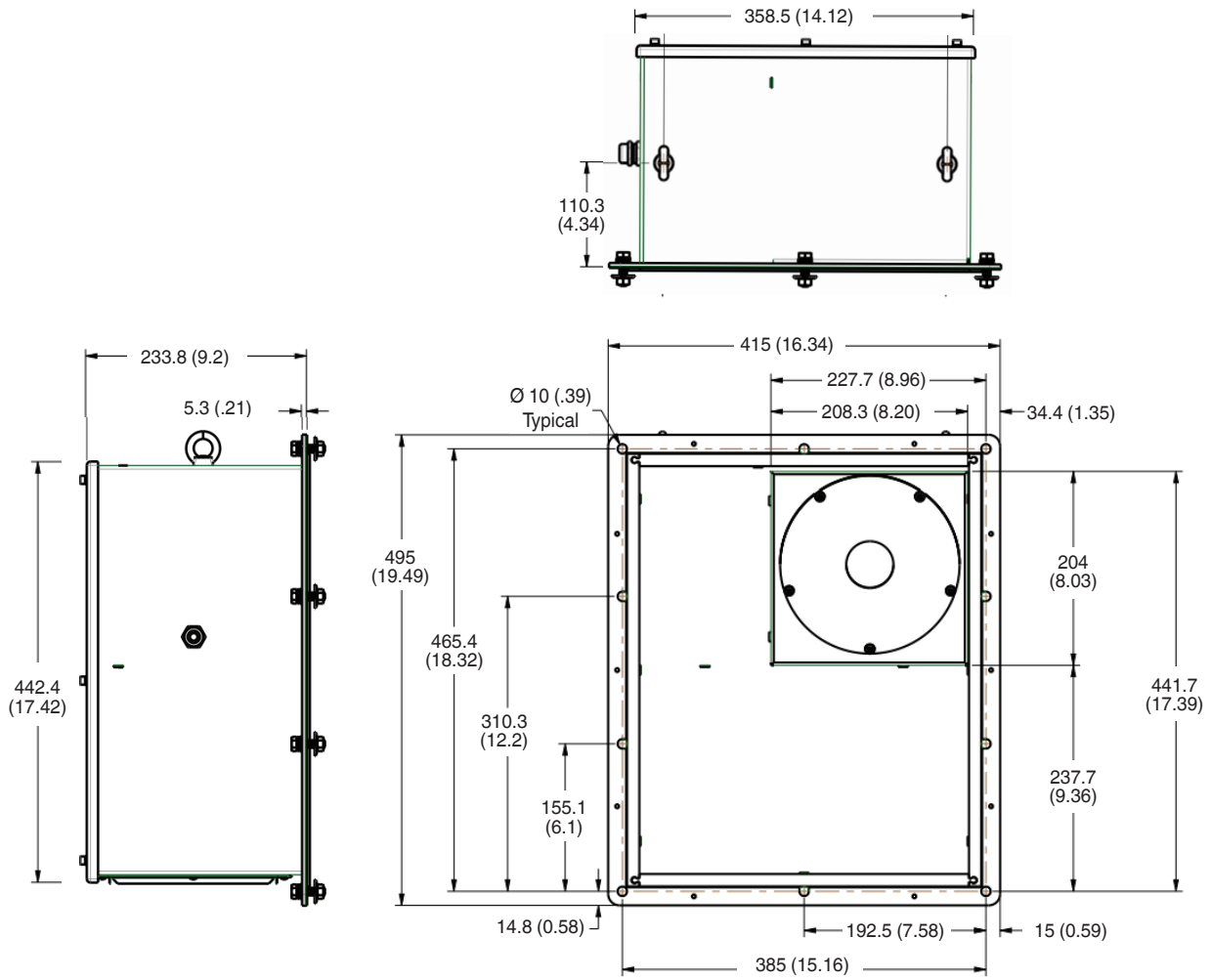

Dimensions shown in mm (in).

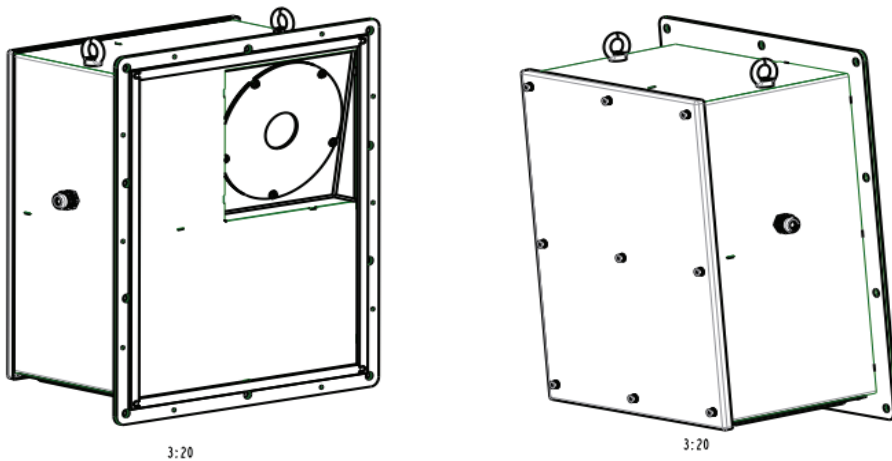

## 2.5.3 Cutout dimensions

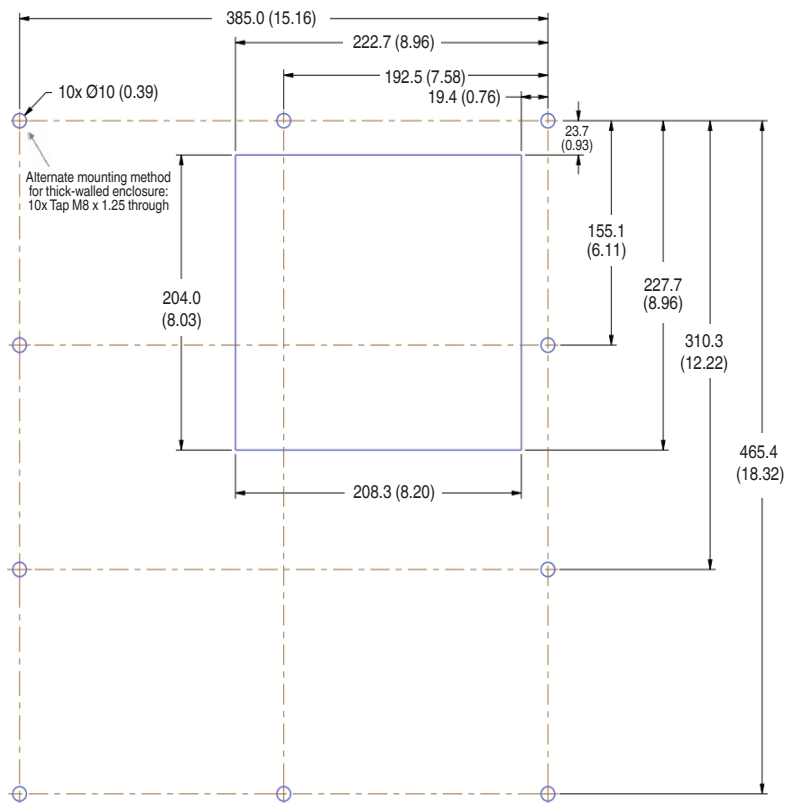

Dimensions shown in mm (in).

## 2.5.4 Mounting the EPV

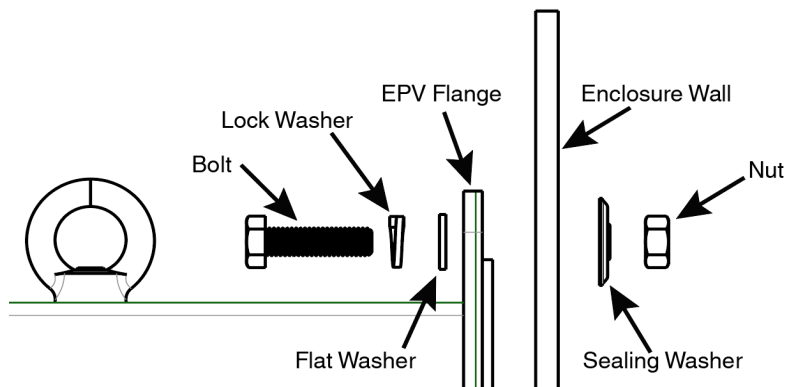

Dimensions shown in mm (in).



### Note

#### Hardware included for M8 mounting holes:

Screw, lock washer, flat washer, sealing washer and nut

Sealing washer and nut are not used for mounting to thick-walled enclosure (wall thickness > 8 mm (5/16 in)).



## 2.6. 6000-TEMP-01 Temperature Hub

### 2.6.1 Technical Data

Item	Value
<b>Electrical specifications</b>	
Connection	6100 Series
Power	Intrinsically safe connection to control unit
Signal	Bus connection to control unit
Connection	Intrinsically safe cabling
Rated voltage ( $U_r$ )	13 VDC
Rated current ( $I_r$ )	max 10mA
Distance	30 m to control unit (max)
<b>Ambient conditions</b>	
Ambient temperature	-20 ... 85 °C (-4 ... 185 °F)
Storage temperature	-40 ... 85 °C (-40 ... 185 °F)
Relative humidity	<95% non-condensing
Vibration resistance	1 g/58 ... 150 Hz
Impact resistance	15 g, 11 ms
<b>Mechanical specifications</b>	
Connection type	Screw terminals
Core cross section	12 ... 30 AWG
Housing material	Akulon S225-KS
Mass	Approx. 110 kg
Dimensions	21.5 mm x 52 mm x 94 mm
Torque requirements	
Terminal blocks	0.5–0.6 Nm

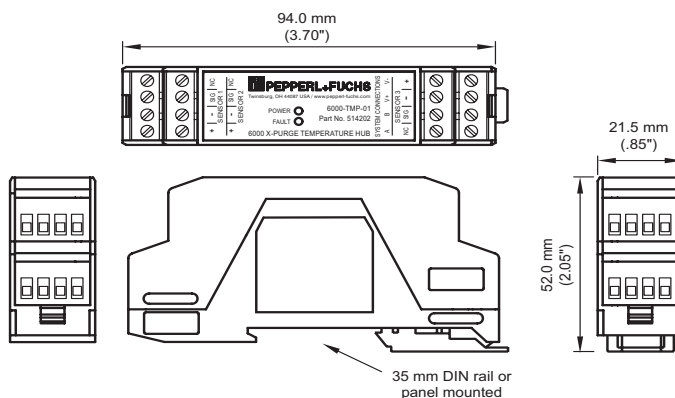

Dimensions shown in mm (in).

## 2.7. 6000-TSEN-01 Temperature sensor

### 2.7.1 Technical Data

Item	Value
<b>Electrical specifications</b>	
Connection	6100 Series
Power	Connection to temperature hub
Rated voltage ( $U_r$ )	5.5 VDC
Rated current ( $I_r$ )	max 10mA
Open loop voltage	9.6 V
Distance	3 m from 6000-TEMP-01
<b>Ambient conditions</b>	
Ambient temperature	-20 ... 100 °C (-4 ... 212 °F)
Storage temperature	-40 ... 100 °C (-40 ... 212 °F)
Relative humidity	<95% non-condensing
Vibration resistance	1 g/58 ... 150 Hz
Impact resistance	15 g, 11 ms
<b>Mechanical specifications</b>	
Housing material	Ryton BR III BL
Cable	gray PVC
Diameter	5.03 mm <sup>2</sup>
Wire gauge	22 AWG
Mass	Approx. 110 kg
Dimensions	10.5 mm x 25 mm x 50 mm



#### Note

6000-TSEN-01 must be used with the 6000-TEMP-01 temperature hub.

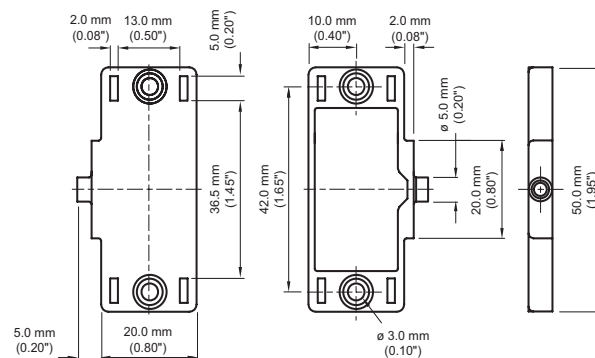

Dimensions shown in mm (in).

# 3. Installation and Operation

## 3.1. Electrical Installation

### 3.1.1 General wiring notes

#### For Power Connections to the 6100 Control Unit and Relay Contacts:

1. All applicable local and national wiring codes MUST be followed when wiring to the unit.
2. Wire should be copper only, rated 90 °C minimum. Minimum of 0.25 mm wire insulation thickness required.
3. Ensure that electrical, mechanical, and pneumatic connections and requirements are met to operate this system. Refer to this manual and applicable standards/codes, including current edition of the EN/IEC 60079-14. Electrical supply to the purge system shall be supplied through a switch or circuit breaker and suitably located and easily reached and must be marked as the disconnect for the equipment.
4. Power must be removed from the system when the Ex d enclosure cover is off or if the Ex e power terminal cover is removed, unless the area is known to be non-hazardous.

### 3.1.2 Wiring parameters

<b>Intrinsically safe wiring terminals, internal to enclosure</b>	solid min: 0.2 mm <sup>2</sup> solid max: 4 mm <sup>2</sup> stranded min: 0.25 mm <sup>2</sup> stranded max: 2.5 mm <sup>2</sup> stranded with ferrule without plastic sleeve min: 0.2 mm <sup>2</sup> stranded with ferrule without plastic sleeve max: 1.5 mm <sup>2</sup> stranded with ferrule with plastic sleeve min: 0.25 mm <sup>2</sup> stranded with ferrule with plastic sleeve max: 2.5 mm <sup>2</sup> AWG min: 30 AWG max: 12 torque: 0.5 Nm ... 0.6 Nm stripping length: 7 mm
<b>Ex e terminals, internal to enclosure</b>	rated cross section: 2.5 mm <sup>2</sup> / AWG 14 connection capacity rigid: 0.14 mm <sup>2</sup> ... 4 mm <sup>2</sup> / AWG 26–12 connection capacity flexible: 0.14 mm <sup>2</sup> ... 2.5 mm <sup>2</sup> / AWG 26–14 2 conductors with same cross section, rigid: 0.14 mm <sup>2</sup> ... 1.5 mm <sup>2</sup> / AWG 26–16 2 conductors with same cross section, flexible: 0.14 mm <sup>2</sup> ... 1.5 mm <sup>2</sup> / AWG 26–16 stripping length: 9 mm torque: 0.5 Nm ... 0.6 Nm



## DANGER!

To prevent ignition of the flammable atmospheres, the wiring method must ensure that if any wire is disconnected and extended to the opposite terminal, a two-inch separation must be maintained.

### For Wires Going to the DIN-Rail-Mount I.S. Board in the 6100 Control Unit:

1. The only terminals that might have multiple connections are the shield connections. These must be crimped to a single pin before connection to the board.
2. If cables are used (recommended for connections to the vents and UIC), it is recommended that the cables be shielded.
3. The wires must have a minimum insulation thickness of 0.25 mm (0.01”).
4. Wire should be copper only, rated 90 °C minimum.
5. The minimum wire strand in a stranded wire should have a diameter of 0.1 mm or greater.

## 3.1.3 Power and intrinsically safe wiring

If the protective enclosure has been opened or has been subjected to the hazardous atmosphere, the enclosure must be manually cleaned of all combustible dust, closed, and pressurized before supplying power to the enclosure.

Power / Auxiliary Wiring

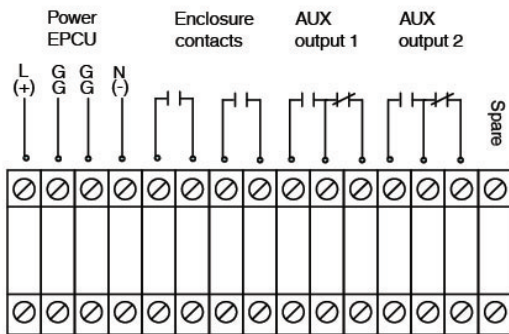

Intrinsically Safe Wiring

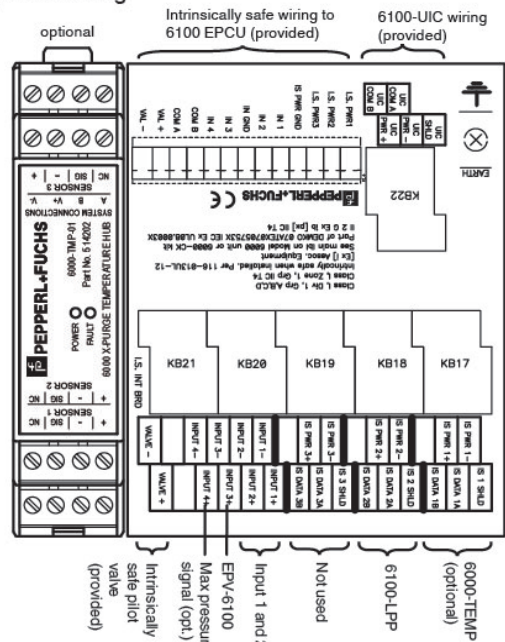

**Connector color code for the user interface, temperature module, and LPP:**

PWR+	BN (brown)
PWR-	BU (blue)
DATA_A	WH (white)
DATA_B	BK (black)

**CAUTION!**

Maintain a minimum space of 50 mm (2") between the I.S. wiring and the non-I.S. wiring. Make sure that the wiring is neatly tucked into the explosionproof housing. Use wire ties if necessary. As a rule, no wires are to be in the area between the two terminals.

**Note**

When removing the terminal block from the EPCU stack, place your hand on the top of the plastic cover, where the Pepperl+Fuchs label is, to support the stack.

**Note**

The EPCU is prewired to the I.S. terminal board.

**Note**

Both enclosure power contacts are switched at the same time.

## 3.2. Pneumatic requirements

### 3.2.1 Protective gas supply

The protective gas supply to the enclosure system must be a clean quality compressed air or inert gas.

The protective gas supply compressor intake must originate in a nonhazardous location. The supply duct passing through a hazardous location and the protective tubing and piping must be fabricated from noncombustible material suitable for the prevailing hazardous and environmental conditions.

The protective gas supply provided must be able to handle the flow and pressure requirements for purging and pressurization. The published flow for purging will require more flow due to leakages in the enclosure and safety factors added to the measurement.

In addition, according to IEC 60079-14:

*The protective gas used for purging, pressurization, and continuous dilution shall be non-combustible and non-toxic. It shall also be substantially free from moisture, oil, dust, fibres, chemicals, combustibles and other contaminating material that may be dangerous or affect the satisfactory operation and integrity of the equipment. It will usually be air, although an inert gas may be used, particularly when there is an internal source of release of flammable material. The protective gas shall not contain more oxygen by volume than that normally present in air.*

*Where air is used as the protective gas, the source shall be located in a non-hazardous area and usually in such a position as to reduce the risk of contamination. Consideration shall be given to the effect of nearby structures on air movement and of changes in the prevailing wind direction and velocity. Care should be taken to keep the temperature of the protective gas below 40 °C at the inlet of the enclosure. In special circumstances, a higher temperature may be permitted or a lower temperature may be required, in which case the temperature shall be marked on the pressurized enclosure.*

*Where inert gas is used, particularly in large enclosures, measures shall be taken to prevent the danger of suffocation. Pressurized enclosures using inert gas as the protective gas should be marked to indicate the hazards, for example:  
"WARNING – THIS ENCLOSURE CONTAINS INERT GAS AND THERE MAY BE A DANGER OF SUFFOCATION. THIS ENCLOSURE ALSO CONTAINS A FLAMMABLE SUBSTANCE THAT MAY BE WITHIN THE FLAMMABLE LIMITS WHEN EXPOSED TO AIR".*

### 3.2.2 Pneumatic Connections

The 6100 series system requires five or six pneumatic connections from the user.

The connections for the protective gas are made on bottom of the 6100 control unit and have an inlet and outlet, 1¼ inch FNPT fittings.

Connect outlet to enclosure/motor. It is recommended to use 1¼ inch pipe and to minimize the number of bends and/or elbows or tees that are used during the routing process.

The EPV-6100 vent has to be mounted to the enclosure, and a specified opening for the flow of purge gas from the enclosure through the vent is required. See mounting dimensions for the EPV-6100 vent.

The 6100-MP-LPP has to be mounted to the enclosure and a specified clearance hole is specified for proper fit. See mounting dimensions for 6100-MP-LPP.

For the no-regulator option, the pilot valve that is inside the 6100 control unit has a ¼" compression fitting on bottom of the enclosure for connection to a supply line. The minimum pressure requirement is 4.1 bar. This connection should be upstream from the regulator for the purge gas supply, since the purge gas supply regulator can be adjusted for correct flow for purging and pressurization.



## Note

### For the “No Regulator” version of this product:

Pressure for the intrinsically safe pilot valve to actuate the purging valve requires a minimum of 4.1 bar, and the purging and pressurization system can be adjusted below 4.1 bar. Note that if this is the case, the pilot valve air supply should be upstream of the regulated supply for the purging and pressurization and requires a minimum of 4.1 bar.

The maximum pressure value is 8.3 bar.

## 3.2.3 Pressurization Adjustments

To adjust the pressurization, rotate the gate valve counter-clockwise to open the valve. Before adjusting flow, make sure the control unit is on and the user-interface is reading pressure, or have a pressure gauge on the enclosure to read enclosure pressure.

## 3.2.4 Purging Adjustment

When purging begins, the small intrinsically safe pilot valve will energize, which will pneumatically energize the angle seat valve for purging. If the control unit is set up for fully automatic (FA), it will automatically start this process when safe pressure is achieved. For SA (semi-automatic) or STD (manual) mode, the user will have to start purging through the command on the user-interface. Flow to the enclosure can be adjusted by varying the regulator (not supplied for the “no regulator” option). If the regulator is adjusted during this process, re-adjustment of the gate valve for pressurization may be required since the pressure source is the same for both pressurization and purging.

## 3.3. Operation

### 3.3.1 Turning on Power to the Enclosure

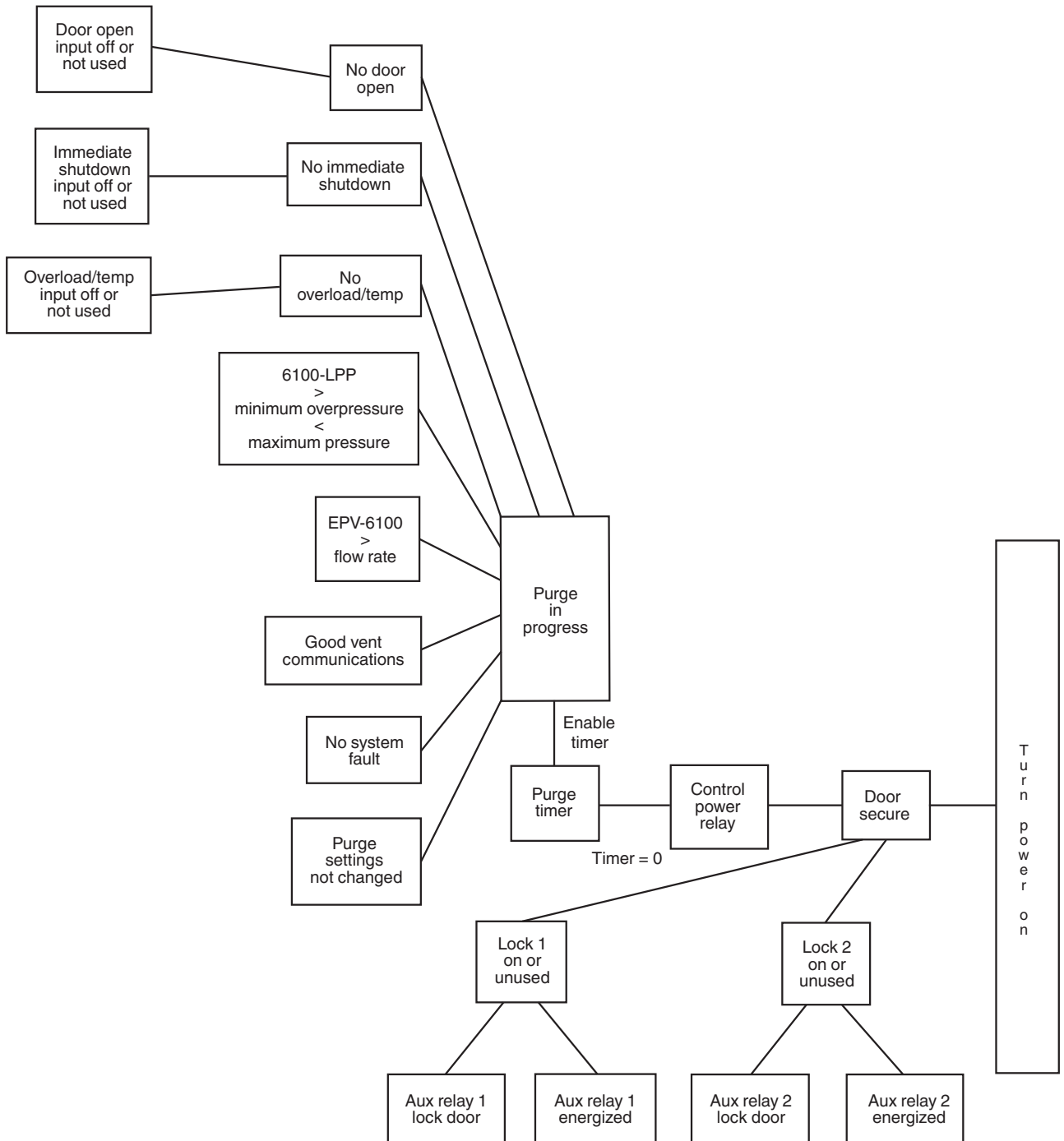



### 3.3.2 Turning off Power to the Enclosure

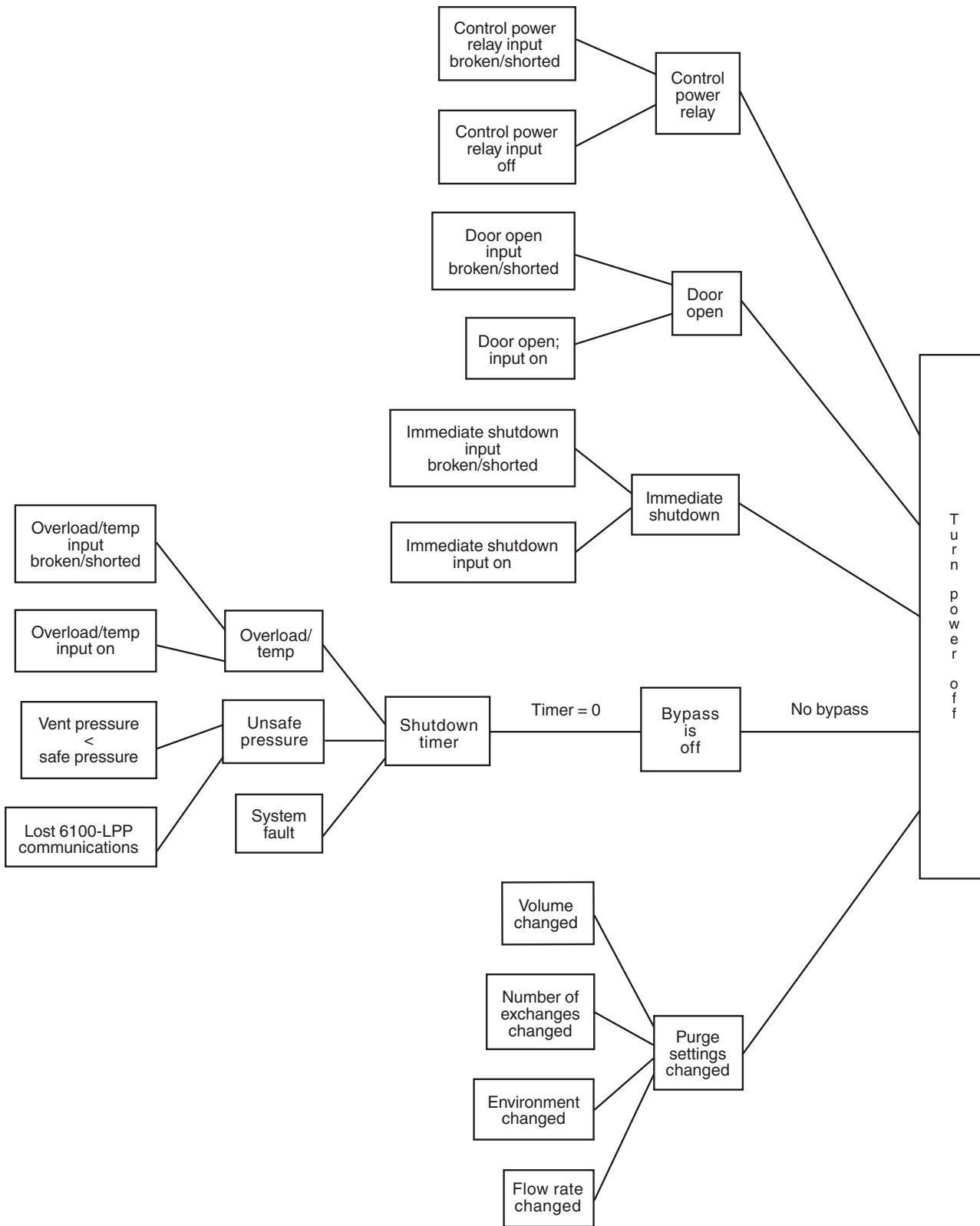

### 3.3.3 6100 Series System Components

The 6100 series consists of the 6100-MP-EX-XX-XXX control unit, which includes the pneumatic components for purging and pressurization and user interface, the EPV-6100-MP-XXX-XXX enclosure vent, and the 6100-MP-LPP-01 pressure sensor. All three device are separate items. Optional temperature sensing devices are available for temperature monitoring/control.

#### 6100 Control Unit Components

- EPCU mounted in an explosion proof / flameproof enclosure
- Intrinsically safe interface with display and cable pre-installed
- Intrinsically safe termination board pre-wired to the EPCU
- Pneumatic system for purging and pressurization
  - Angle seat valve for purging, which is actuated from an intrinsically safe pilot valve
  - Manual gate valve for pressurization
  - Manual gate valve for regulation
  - Optional regulator for purge gas supply
  - Copper tubing, 1¼" for valve connections
  - Inlet and outlet connection, 1¼" FNPT stainless steel for purging supply and enclosure connection
- Stainless steel IP66 enclosure
- Customer terminal connections

#### 6100 Enclosure Protection Vent Components (EPV)

- Stainless steel housing with stainless steel spark arrestor
- Specified orifice plate and pressure switch mounted and adjusted for required flow rate
- 3 m cable for intrinsically safe connection to I.S. output 3 on the I.S. termination board in the 6100 control unit

#### 6100 Pressure Sensor Components (LPP)

- Pressure sensor mounted in 6061 anodized aluminum block
- 1½" NPSM process connection
- Connector cable (5m, supplied)
- I.S. wiring labels



#### Note

The EPV-6100 vent must be mounted in an orientation so that the vent opening (screen opening) is facing toward the ground.

## i

**Note**

The flow rate through the system must be higher than the specified flow rate required for the purge because of leakage from the enclosure and safety tolerances due to temperature, barometric pressure, switch tolerances, and general tolerances of the system.

**Electronic Power Control Unit—EPCU**

The EPCU houses the redundant microprocessors, enclosure power contacts, (2) auxiliary contacts, power supply module, galvanically isolated barriers for the inputs, vent, and temperature modules. The EPCU is available in 20 ... 30 VDC or 100 ... 250 VAC units. The enclosure power contacts are force-guided safety relays. The auxiliary contacts can be user configured for different functions, depending on user requirements.

**User Interface Controller—UIC**

The 6100 series is user programmable for many of the configurable options available. This is done with the intrinsically safe user interface on the face of the unit, which can also be remote mounted. The user interface contains a 2 x 20 LCD that allows programming through a set of buttons on the menu-driven unit. All configuration and options are programmed through this unit. There are also (5) LEDs for easy visual indication of operation:

- Safe pressure—This turns on (blue) when safe pressure is achieved inside the enclosure
- Enclosure power—This is illuminated (green) when the enclosure is on. The enclosure power can be on only after a successful purge and a safe pressure is achieved. The bypass option allows power to remain on if safe pressure is lost.
- Rapid Exchange®—The rapid exchange or purging flow rate turns on (blue) when the flow rate is measuring proper flow.
- System bypass—This turns on (yellow) when the system bypass is active. This should be used only when the area around the enclosure is known to be safe.
- Alarm fault—The red LED blinks when any alarm input is detected and is solid when there is an internal system fault.

**3.3.4 Requirements for Purging/Pressurizaion**

Certifications allow the 6100 series to be used on enclosures in hazardous gas atmospheres. Gas atmospheres require purging of the enclosure. After the purge cycle is complete and the pressure within the enclosure is above the minimum safe pressure, the equipment within the enclosure can be energized.

### Purge Timing

The enclosure purging time is based on the enclosure volume, the number of exchanges required, and the EPV-6100 vent being used. These parameters are entered by the user with the enclosure volume and number of exchanges provided by the user and the EPV-6100 vent flow rated listed on the data for the specific model.

Example:

- The enclosure volume is 14,000 liters.
- The number of exchanges is 10.
- The vent is the EPV-6100-MP-080-XXX (required flow rate for purging is 8000L/min)

$$\text{Purge time} = (14000 * 10) / 8000 = 17.5 \text{ min}$$

Same example, different vent:

- The enclosure volume is 14,000 liters.
- The number of exchanges is 10.
- The vent is the EPV-6100-MP-110-XXX (required flow rate for purging is 11,000 L/min)

$$\text{Purge time} = (14000 * 10) / 11000 = 12.7 \text{ min}$$



### Note

The following parameters must be entered for the purge time:

- Enclosure volume
- Number of exchanges
- Type of vent for flow rate—enter flow rate specified on the vent in use.

Minimum purge time is 2 min.

### Fixed Purge Time

The purge time is based on the known enclosure volume, number of volume exchanges, and flow rate through the vent. If the flow rate is below the required minimum, then the purging cycle will reset and will not start until the flow rate is above the selected rate. The purge time is calculated by the EPCU.

### Purging Modes

Purging startup can be set in three different modes: the EPCU.

- STD—Standard mode requires the operator to engage the manifold solenoid valve manually when purging and manually disengage when a successful purging is complete.
- SA—Semi-automatic mode requires the operator to engage the manifold solenoid valve manually when purging. The EPCU will automatically disengage when a successful purging is complete.
- FA—Fully-automatic mode will automatically engage the manifold solenoid valve when safe pressure is detected and will automatically disengage when a successful purging is complete.

The minimum purge time is two minutes.

During the purging cycle, when the enclosure pressure reaches 0.62 mbar (0.25 in wc) or higher, there will be a 5 second delay before the rapid exchange solenoid valve is activated. If the flow is enough through the vent to satisfy the required flow rate setting, then the timer will begin after 1 min. The update of the timer is in increments of 1 min in the Fixed Purge Time and % completed in the Dynamic Purge Time.

### Pressure as Input

In the programming menu under “INPUT SETTINGS” for the optional pressure control. The pressure control is achieved within the enclosure by opening and closing a purging valve or manifold on the 6100 control unit. These two internal pressure set points are controlled by the manifold or an outside source for pressure. The pressure function can manage the control output 2, or the control valve (manifold valve).

- The “ON PRESSURE” is the lowest pressure you want in the enclosure and will start the control action on when pressure goes below this value.
- The “OFF PRESSURE” is when the valve shuts off. When the pressure is between these two values, nothing will happen.
- The “ON PRESSURE” function is active until the “OFF PRESSURE” is reached.

## i

### Note

This function does not operate during purging cycle and only operates during normal operation.

The “ON PRESSURE” always has to be lower than the “OFF PRESSURE”. This cannot be reversed.

### IS Inputs 1–4

There are four (4) intrinsically safe inputs for activation of various outputs and actions by the EPCU. These inputs only accept a dry contact for activation and are supplied by the EPCU’s galvanically isolated barrier. The configurations of the inputs for various actions are done through the user-interface controller. Only one function can operate per input. To monitor wiring, the SRM-6000 (sensor resistor module, not required, ordered separately) can be added to detect shorts or breaks in the inputs’ wiring to the contacts.

See input configuration for input parameters (Section 4.1.4), which can be configured through the user interface (UIC).

### Outputs

#### Enclosure 1 and Enclosure 2

There are (2) normally open dry contacts for the enclosure power that can be energized only after a successful purging and a minimum enclosure pressure is maintained. Loss of pressure will cause the contacts to de-energize unless the shutdown timer is activated or bypass mode is implemented. These contacts operate simultaneously.

## Auxiliary 1 and Auxiliary 2

The auxiliary outputs can be used for control or alarms. Auxiliary outputs can be programmed by the user for various conditions of the system. See 'OUTPUT' configuration (Section 4.1.5) for output parameters.



### DANGER!

---

Do not use auxiliary contact for power to enclosure(s).

---



### DANGER!

---

If powering auxiliary equipment with auxiliary 1 and auxiliary 2 outputs, the wiring methods used must be suitable for the hazardous area.

---

## Temperature Inputs

The 6000-TEMP-01 temperature hub and 6000-TSEN-01 external temperature sensor(s) are designed to work only with the 6000 and 6100 purge and pressurization systems.

An averaging or maximum temperature input reading from the sensor(s) is used to control a solenoid valve or activate the auxiliary relay to cool or heat the enclosure, or warn of temperature problems.

In the programming menu, under "SENSOR SETUP", "EXT SENSOR COUNT", you can configure up to 3 sensors per temperature hub. Each temperature hub has one embedded temperature sensor. In the programming menu under "INPUT SETTINGS" you will select the "HUB". This must be selected if you want to include the hub as a sensor input.



### Note

---

You may not want to include the temperature as an input if the sensor is not located near the device or process you are tracking the temperature of.

Once a "CONTROL ACTION" is selected, then select "SETPOINT TYPE" for the "AVERAGE" or "SINGLE PT".

---



### Note

---

If using more than one (1) sensor, you may want the control action to occur during the peak or average temperature of the sensors.

"ON SET POINT" and "OFF SET POINT" are the temperatures for the control action.

---



## Note

The “ON SET POINT” can be greater than the “OFF SET POINT”.

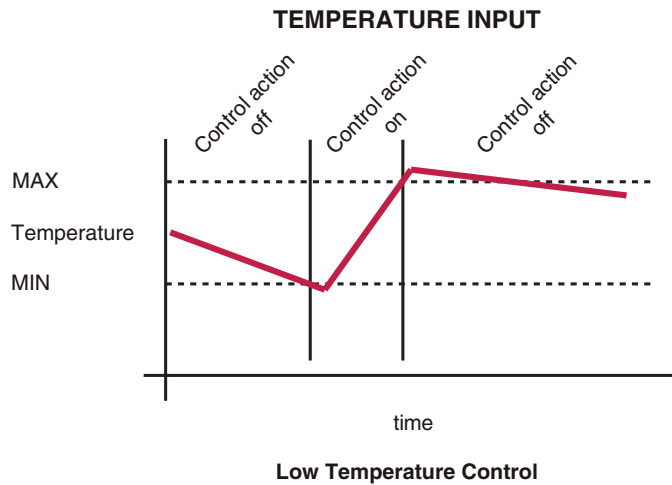

### EPV-6100 I.S. Relief Vent

The EPV-6100 vent exhausts excess pressure from the enclosure when the enclosure pressure exceeds the breaking pressure of the vent’s relief mechanism. The EPV-6100 also has an internal measured orifice plate with a differential pressure sensor to detect pressure across this orifice plate to be converted to a flow rate. The pressure switch is set by the factory for the specific orifice plate and cannot be changed in the field. Once the required flow rate across the orifice plate is achieved, the differential pressure switch closes and sends a signal back to the 6100 EPCU, and purging can start. If at any time during purging the flow drops below the required flow, the timer in the EPCU will reset and purging will not start until required flow is met.

Note that the published flow rate for each vent requires more flow to achieve purging because of leakages in the enclosure and safety factors due to leakage from the enclosure and safety tolerances due to temperature, barometric pressure, switch tolerances and general tolerances of the system.

For example, the published flow rate for the EPV-6100-MP-080-XXX, which is also the flow rate used in the calculation of the purge time, is 8000 l/min, but the actual flow rate required to start purging in a completely sealed enclosure may be 10,000 l/min. However, there is no correction factor for using this over the -20 °C to 60 °C temperature range of elevation changes. This also includes long-term drift and other safety factors.

## 3.3.5 Setup Procedures

This is a recommended procedure for setting up the correct pressurization and purging of an enclosure/motor.

1. Ensure that the electrical, mechanical, and pneumatic connections and requirements are met to operate your system. Refer to this manual and appropriate standards for explanation of requirements.

2. Apply power to the 6100 control unit.
3. This step is for initial setup. The factory default of the 6100 control unit is 'SA' (semi-automatic mode). Purging does not start until it is initiated by the operator on the 6100 display on the control unit. To change this function to FA (fully automatic), see 'Programming Menu' for instructions. Semi-automatic mode should be used for setting pressurization pressures and purging flows initially in the enclosure/motor.
4. The 6100 controller is equipped with a maximum pressure alarm and shut off of the purging valve. This pressure is read by the 6100-MP-LPP-01. Set this value in the purge settings for overpressure protection. If the pressure on the 6100-MP-LPP-01 goes above this maximum pressure, it will shut off the purging valve when in the purging mode.
5. Before applying pressure to the system, verify that the manual gate valve for pressurization' is fully closed by turning clockwise before applying pressure to the system.
6. Turn on the protective gas supply to the 6100 series system inlet on the pneumatic tubing. Make sure line pressure is below 8.2 bar (120 psig).
7. Adjust pressurization and purging values.
  - a. Verify that the manual gate valve for regulation is fully open by turning counterclockwise.
  - b. From the fully closed position, open the manual gate valve for pressurization to about 3 to 4 complete turns (counterclockwise).
  - c. Adjust the supply regulator until the safe pressure LED on the 6100 control unit turns on.
  - d. Adjust the manual gate valve for pressurization so that the pressure is above the minimum pressure set point. This is to compensate for any fluctuation in the supply line.
  - e. Start the purging by pushing 'START/SET' on the 6100 control unit display. The unit should start purging after about 1 second. If the purging begins, then suddenly stops and the alarm LED is flashing, check the alarms in "Statistics" to determine if it is a "Max Pressure" alarm. If so, the maximum pressure set point has been reached by the 6100-MP-LPP-01 pressure sensor. Reduce the pressure by gradually closing the manual gate valve for regulation to reduce the purging flow, which will result in a lower purging pressure. (*See note on page 41 regarding max overpressure.*)
  - f. Adjust the supply regulator so that the pressure in the enclosure is above the purging pressure. See EPV-6100 data for purging pressure per vent size.
  - g. Once this is established, the unit will go through a proper purging. After the system is finished purging the purging valve will shut off and the manual gate valve for pressurization will be compensating for leakages. If the supply regulator was adjusted during the purging phase, the manual gate valve for pressurization may need to be readjusted. If the supply regulator was increased, the manual gate valve for pressurization may need to be decreased. If the regulator was decreased, the manual gate valve for pressurization may need to be increased. The latter may cause the system to drop out of operation and require purging again because it dropped below the minimum pressure value.
8. The system is now ready to operate.





## Note

---

Max overpressure setting is only valid up to 25 mbar.

For a max overpressure above 25 mbar, a separate pressure switch must be used and the max overpressure must be set to that desired pressure.

---

### 3.3.6 Operation in Gas-Hazardous Locations

- Follow setup procedures for the 6100 series system above.
- Pressure is set to a value above the minimum safe pressure of 0.62 mbar [(0.25 in wc), (62 Pa)], or the set value from the user input.
- After a successful purging, and maintaining an enclosure pressure above the minimum safe pressure, the enclosure is considered safe, and power to the enclosure can be energized.
- If the safe pressure drops below the minimum safe pressure, power to the enclosure will be disconnected unless a time delay for shutting off power is implemented (see the requirements for time delay of power shut-off).
- To energize the enclosure again, repeat the procedure.

# 4. Programming

## 4.1. User Interface

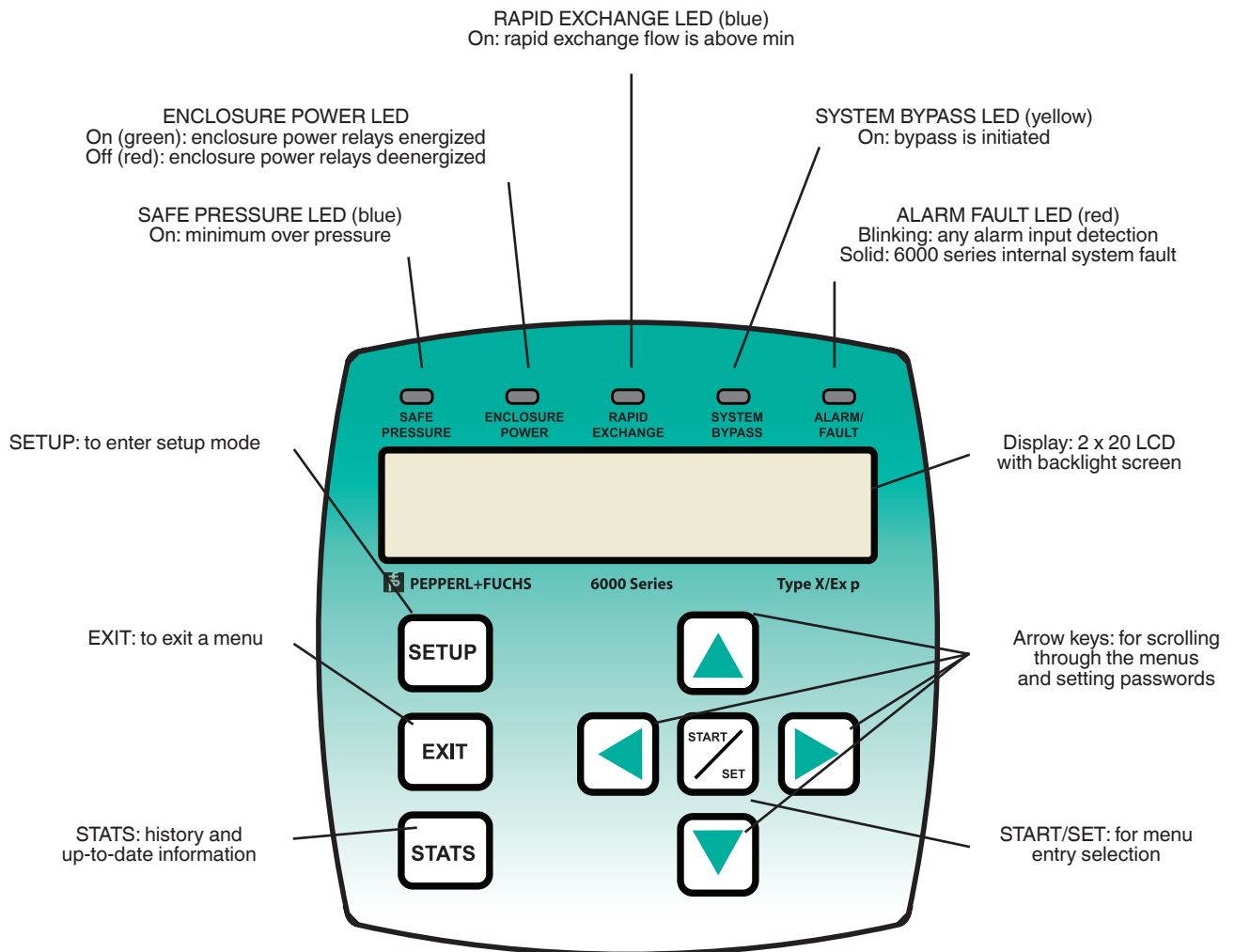

**To cycle power** to the unit, press the EXIT, Left Arrow, START/SET, and Right Arrow keys at the same time. This will cycle power to the EPCU without physically removing power. This re-cycle feature will de-energize the relays of the EPCU and reset the unit. This feature does not affect any of the settings in the menus of the EPCU.

To turn LCD back light on or off, press the left and right arrow keys at the same time. The setting remains through the power cycles.

**To change the LCD contrast**, press the up and down arrow keys at the same time. This will take you to the contrast screen. Then use the up and down arrow keys to adjust the contrast. Once the contrast level is selected, press the START/SET key to save setting. This setting remains through power cycles.

## 4.1.1 Programming Menu

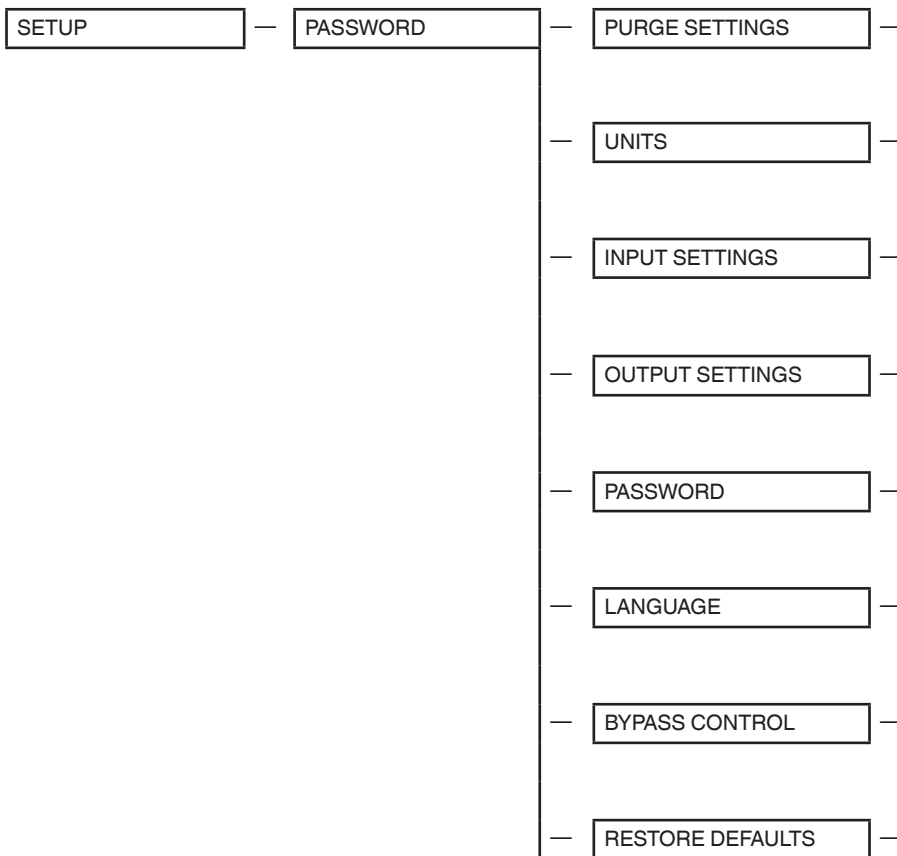

### 4.1.2 Purge Settings

PURGE SETTINGS	ENCLOSURE VOLUME	USER DEFINED	SETTING CORRECT Y/N	
	NUMB OF EXCHANGES.	4 - 19	SETTING CORRECT Y/N	
	FLOW VALUE	USER DEFINED	SETTING CORRECT Y/N	
	VENT FLOW CONTROL	ONE VENT	SETTING CORRECT Y/N	
	ENVIRONMENT	MOTOR	SETTING CORRECT Y/N	
	PRESSURES	MAX OVER PRESSURE	XX.XX	SETTING CORRECT Y/N
		LOW PRESSURE	XX.XX	SETTING CORRECT Y/N
		MIN OVER PRESSURE	XX.XX	SETTING CORRECT Y/N
	TIMERS	PURGE TIMER	READ ONLY - FIXED TIME.	SETTING CORRECT Y/N
		SHUTDOWN TIMER	0 - 300 SEC.	SETTING CORRECT Y/N
		UNLOCK DOOR TIMER	0 - 300 MIN.	SETTING CORRECT Y/N
		BYPASS OFF TIMER	0 - 300 SEC.	SETTING CORRECT Y/N
	OPERATION MODE	STD, *SA, FA	SETTING CORRECT Y/N	

### 4.1.3 Units

UNITS	ENGLISH	SETTING CORRECT Y/N
	METRIC	SETTING CORRECT Y/N

### 4.1.4 Inputs

INPUT SETTINGS	INPUT 1	INPUT 1 FUNCTION	DISABLED	SETTING CORRECT Y/N
			IMMEDIATE SHTDN	SETTING CORRECT Y/N
			DOOR OPEN ALARM	SETTING CORRECT Y/N
			OVERLOAD	SETTING CORRECT Y/N
			CONTROL PWR RELAY	SETTING CORRECT Y/N
			CONTROL OUTPUT 1	SETTING CORRECT Y/N
			CONTROL OUTPUT 2	SETTING CORRECT Y/N
			SOLENOID VALVE	SETTING CORRECT Y/N
			SYSTEM BYPASS	SETTING CORRECT Y/N
			INPUT 1 SRM	SRM YES,NO
	INVERT INPUT 1?	INVERT YES, NO	SETTING CORRECT Y/N	

INPUT 2	INPUT 2 FUNCTION	DISABLED	SETTING CORRECT Y/N
		IMMEDIATE SHTDN	SETTING CORRECT Y/N
		DOOR OPEN ALARM	SETTING CORRECT Y/N
		OVERLOAD	SETTING CORRECT Y/N
		CONTROL PWR RELAY	SETTING CORRECT Y/N
		CONTROL OUTPUT 1	SETTING CORRECT Y/N
		CONTROL OUTPUT 2	SETTING CORRECT Y/N
		SOLENOID VALVE	SETTING CORRECT Y/N
		MAX PRESSURE SIGNAL	SETTING CORRECT Y/N
		INPUT 2 SRM	SRM YES,NO
INVERT INPUT 2?	INVERT YES, NO	SETTING CORRECT Y/N	
INPUT 3	FLOW SIGNAL		
	INPUT 3 SRM	SRM YES, NO	SETTING CORRECT Y/N
	INVERT INPUT 3?	INVERT YES, NO	SETTING CORRECT Y/N
INPUT 4	INPUT 4 FUNCTION	DISABLED	SETTING CORRECT Y/N
		IMMEDIATE SHTDN	SETTING CORRECT Y/N
		DOOR OPEN ALARM	SETTING CORRECT Y/N
		OVERLOAD	SETTING CORRECT Y/N
		CONTROL PWR RELAY	SETTING CORRECT Y/N
		CONTROL OUTPUT 1	SETTING CORRECT Y/N
		CONTROL OUTPUT 2	SETTING CORRECT Y/N
		SOLENOID VALVE	SETTING CORRECT Y/N
		MAX PRESSURE SIGNAL	SETTING CORRECT Y/N
		INPUT 4 SRM	NO, YES
INVERT INPUT 4?	NO, YES	SETTING CORRECT Y/N	

PRESS AS INPUT	PRESS FUNCTION	SETTING CORRECT Y/N	SETTING CORRECT Y/N		
		CONTROL OUTPUT 1	SETTING CORRECT Y/N		
		CONTROL OUTPUT 2	SETTING CORRECT Y/N		
		SOLENOID VALVE	SETTING CORRECT Y/N		
	ON PRESSURE	ON PRESSURE	XX.X MBAR (IN WC)	SETTING CORRECT Y/N	
		OFF PRESSURE		SETTING CORRECT Y/N	
	OFF PRESSURE	OFF PRESSURE	XX.X MBAR (IN WC)	SETTING CORRECT Y/N	
		OFF DELAY TIME		SETTING CORRECT Y/N	
	OFF DELAY TIME	OFF DELAY TIME	XX SECONDS	SETTING CORRECT Y/N	
	TEMP INPUT	SENSOR SETUP	EXT SENSOR COUNT	XX	SETTING CORRECT Y/N
			USE HUB SENSOR	HUB YES, NO	SETTING CORRECT Y/N
TEMP INPUT 1		TEMP FUNCTION	DISABLED	SETTING CORRECT Y/N	
		TEMP FUNCTION	IMMEDIATE SHTDN	SETTING CORRECT Y/N	
			DOOR OPEN ALARM	SETTING CORRECT Y/N	
			OVERLOAD	SETTING CORRECT Y/N	
			CONTROL PWR RELAY	SETTING CORRECT Y/N	
			CONTROL OUTPUT 2	SETTING CORRECT Y/N	
			CONTROL VALVE	SETTING CORRECT Y/N	
		ALARM	SETTING CORRECT Y/N		
SETPOINT TYPE		AVERAGE SINGLE PT	SETTING CORRECT Y/N		
ON SET POINT		XX °C (°F)	SETTING CORRECT Y/N		
OFF SET POINT		XX °C (°F)	SETTING CORRECT Y/N		

TEMP INPUT 2	TEMP FUNCTION	DISABLED	SETTING CORRECT Y/N
	TEMP FUNCTION	IMMEDIATE SHUTDOWN	SETTING CORRECT Y/N
		DOOR OPEN ALARM	SETTING CORRECT Y/N
		OVERLOAD	SETTING CORRECT Y/N
		CONTROL PWR RELAY	SETTING CORRECT Y/N
		CONTROL OUTPUT 2	SETTING CORRECT Y/N
		CONTROL VALVE	SETTING CORRECT Y/N
		ALARM	SETTING CORRECT Y/N
	SETPOINT TYPE	AVERAGE SINGLE PT	SETTING CORRECT Y/N
	ON SET POINT	XX °C (°F)	SETTING CORRECT Y/N
	OFF SET POINT	XX °C (°F)	SETTING CORRECT Y/N

### 4.1.5 Outputs

OUTPUT SETTINGS	OUTPUT 1 FUNCTION	DISABLED	SETTING CORRECT Y/N
		IMMED SHUTDOWN ALARM	SETTING CORRECT Y/N
		DOOR OPEN ALARM	SETTING CORRECT Y/N
		OVERLOAD/TEMP ALARM	SETTING CORRECT Y/N
		MAX PRESSURE ALARM	SETTING CORRECT Y/N
		LOW PRESSURE ALARM	SETTING CORRECT Y/N
		LOST PRESSURE ALARM	SETTING CORRECT Y/N
		ANNOUNCE PURGE	SETTING CORRECT Y/N
		ANY ALARM	SETTING CORRECT Y/N
		ENCL DOOR LOCK	SETTING CORRECT Y/N
		TEMP INPUT 1 ALARM	SETTING CORRECT Y/N
		TEMP INPUT 2 ALARM	SETTING CORRECT Y/N
		TEMP INPUT 2 ALARM	SETTING CORRECT Y/N
		SOLENOID VALVE	SETTING CORRECT Y/N
	OUTPUT 2 FUNCTION	DISABLED	SETTING CORRECT Y/N
		IMMED SHUTDOWN ALARM	SETTING CORRECT Y/N
		DOOR OPEN ALARM	SETTING CORRECT Y/N
		OVERLOAD/TEMP ALARM	SETTING CORRECT Y/N
		MAX PRESSURE ALARM	SETTING CORRECT Y/N
		LOW PRESSURE ALARM	SETTING CORRECT Y/N
		LOST PRESSURE ALARM	SETTING CORRECT Y/N
		ANNOUNCE PURGE	SETTING CORRECT Y/N
		ANY ALARM	SETTING CORRECT Y/N
		ENCL DOOR LOCK	SETTING CORRECT Y/N
TEMP INPUT 1 ALARM	SETTING CORRECT Y/N		
TEMP INPUT 2 ALARM	SETTING CORRECT Y/N		
SOLENOID VALVE	SETTING CORRECT Y/N		

### 4.1.6 Password

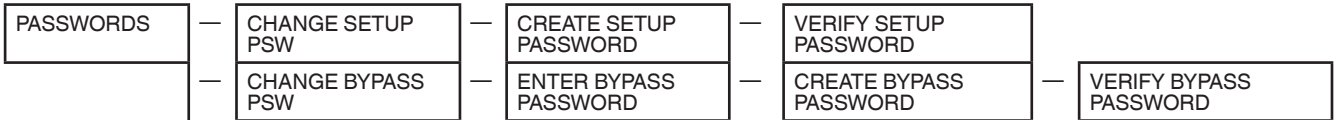

### 4.1.7 Language

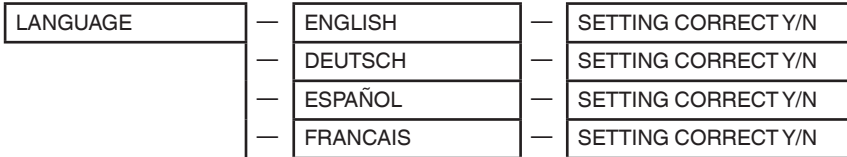

### 4.1.8 Bypass Control

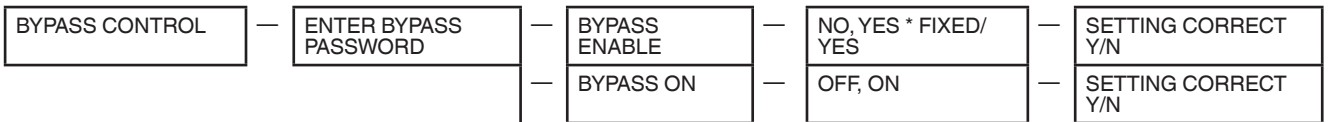

### 4.1.9 Restore Defaults

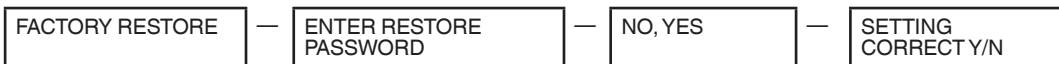

### 4.1.10 Stats

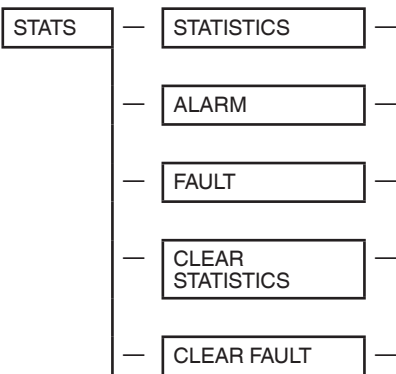



### 4.1.11 Statistics

This provides system operating information. These fields are read only.

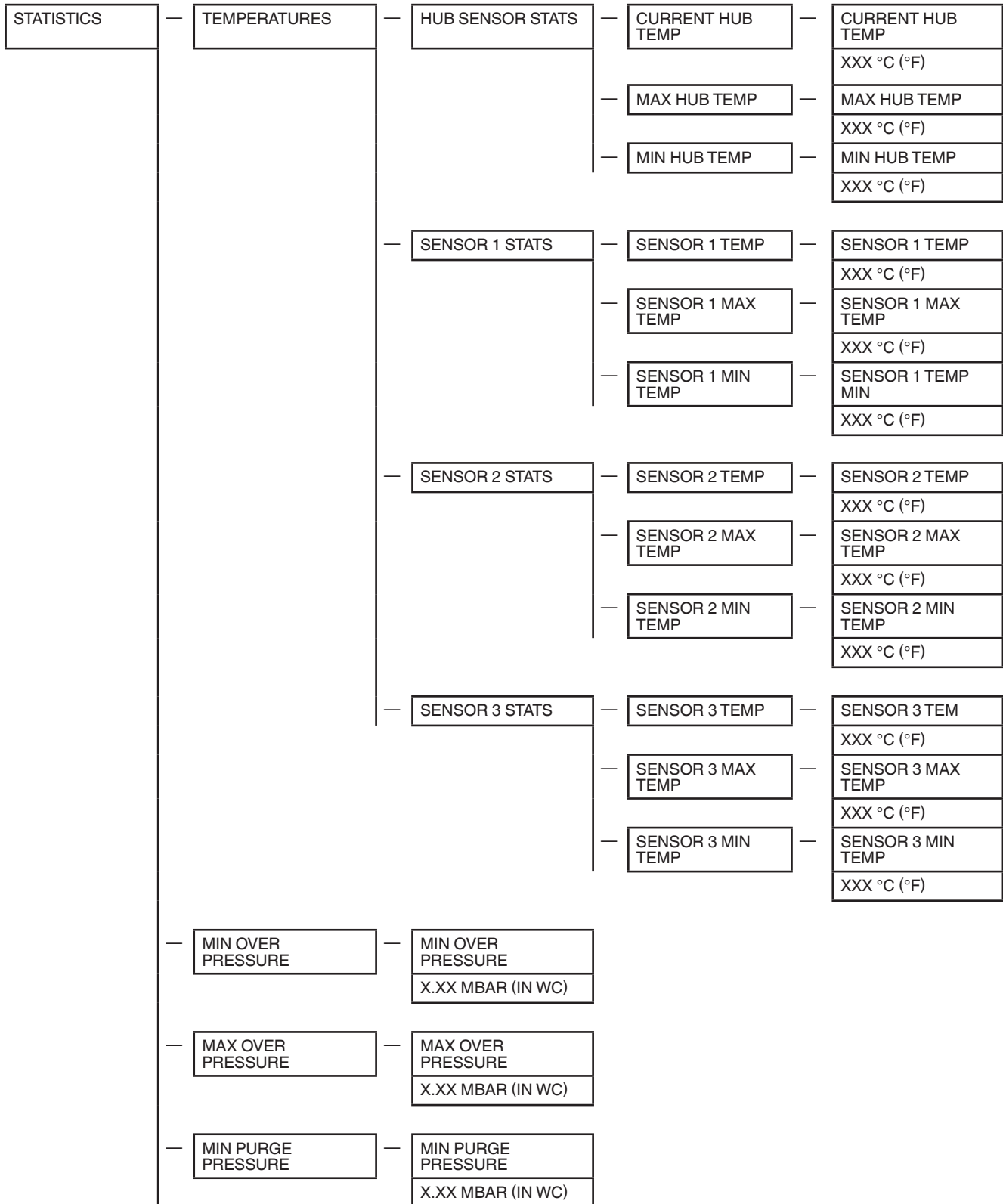

—	MAX PURGE PRESSURE	—	MAX PURGE PRESSURE	—		—	
		—	X.XX MBAR (IN WC)				
—	X6000 PURGE UP TIME	—	X6000 PURGE TIME	—		—	
		—	XX HOURS				
—	LAST SHUTDOWN	—	LAST SHUTDOWN	—		—	
		—	XX HOURS				
—	SHUTDOWN REASON	—	REASON	—		—	
—	COM ERROR COUNT	—	XX	—		—	
—	P+F 6000 REVISION	—	MAIN UNIT	—	HARDWARE REVISION	—	X.XX
		—		SOFTWARE REVISION	—	X.XX	
		—	USER INTERFACE	—	HARDWARE REVISION	—	X.XX
		—		SOFTWARE REVISION	—	X.XX	
		—	VENT 1	—	HARDWARE REVISION	—	X.XX
		—		SOFTWARE REVISION	—	X.XX	
		—	TEMPERATURE HUB	—	HARDWARE REVISION	—	X.XX
		—		SOFTWARE REVISION	—	X.XX	

CURRENT FAULT	NONE
	CONTROL OUTPUT 1
	CONTROL OUTPUT 2
	CONTROL VALVE
	ENCLSR PWR RELAY
	INPUT 1
	INPUT 2
	INPUT 3
	INPUT 4
	13 V POWER
	9.5 V POWER
	FLOW READING
	CONFIG STORAGE
	VENT 1 UPDATE
	CRC MISMATCH
	VENT 2 UPDATE
	VALVE
	VENT 1 FLOW UPDATE
	VENT 2 FLOW UPDATE
	TEMPERATURE UPDATE
INTERNAL RAM	
LAST FAULT	NONE
	CONTROL OUTPUT 1
	CONTROL OUTPUT 2
	CONTROL VALVE
	ENCLSR PWR RELAY
	INPUT 1
	INPUT 2
	INPUT 3
	INPUT 4
	13 V POWER
	9.5 V POWER
	FLOW READING
	CONFIG STORAGE
	VENT 1 UPDATE
	CRC MISMATCH
	VENT 2 UPDATE
	VALVE
	VENT 1 FLOW UPDATE
	VENT 2 FLOW UPDATE
	TEMPERATURE UPDATE
INTERNAL RAM	

### 4.1.12 Alarm

This provides the reason for the last system alarm.

ALARM	—	NONE
	—	NO SAFE PRESSURE
	—	MAX PRESSURE
	—	INPUT 1 BROKE/ SHORT
	—	INPUT 2 BROKE/ SHORT
	—	INPUT 3 BROKE/ SHORT
	—	INPUT 4 BROKE/ SHORT
	—	DOOR OPEN
	—	IMMEDIATE SHUTDOWN
	—	OVERLOAD SHUTDOWN
	—	LOST FLOW
	—	13 V
	—	9.5 V
	—	TEMP INPUT 1
	—	TEMP INPUT 2
—	PRESSURE AS INPUT	

### 4.1.13 Fault

This provides the reason for the system fault.

FAULT	—	NONE
	—	CONTROL OUTPUT 1
	—	CONTROL OUTPUT 2
	—	CONTROL VALVE
	—	ENCLOSURE POWER RELAY
	—	INPUT 1
	—	INPUT 2
	—	INPUT 3
	—	INPUT 4
	—	13 VOLT POWER
	—	9.5 VOLT POWER
	—	FLOW READING
	—	CONFIG STORAGE
	—	VENT 1 UPDATE
	—	CRC MISMATCH
	—	VENT 2 UPDATE
	—	VALVE
	—	VENT 1 FLOW UPDATE
	—	VENT 2 FLOW UPDATE
	—	TEMPERATURE UPDATE
—	INTERNAL RAM	

### 4.1.14 Clear Statistics



### 4.1.15 Clear Fault



## 4.2. Programming Worksheet

SETUP	PASSWORD	PURGE SETTINGS	ENCLOSURE VOLUME (XXXX FT3 [M3])	USER DEFINED		
			# OF EXCHANGES (5)	4 - 19		
			FLOW VALUE (12)	USER DEFINED		
			VENT FLOW CONTROL (ONE VENT)	ONE VENT		
			ENVIRONMENT (GAS)	MOTOR		
			PRESSURES	MAX OVER PRESSURE (10 MBAR [4.0 IN WC])		
				LOW PRESSURE (10 MBAR [4.0 IN WC])		
				MIN OVER PRESSURE (0.63 MBAR [0.25 IN WC])		
			TIMERS	PURGE TIMER	READ ONLY - FIXED TIME	
				SHUTDOWN TIMER (0 SEC.)	0 - 300 SEC.	
				UNLOCK DOOR TIMER (0 MIN)	0 - 300 MIN.	
				BYPASS OFF TIMER	0 - 300 MIN.	
			OPERATION MODE (FA)	STD, SA, FA		
		UNITS (ENGLISH)	ENGLISH			
			METRIC			

INPUT SETTINGS	INPUT 1	INPUT 1 FUNCTION (DISABLED)	DISABLED	
			IMMEDIATE SHTDN	
			DOOR OPEN ALARM	
			OVERLOAD	
			CTRL PWR RELAY	
			CTRL OUTPUT 1	<input type="checkbox"/>
			CTRL OUTPUT 2	
			SOLENOID VALVE	
			MAX PRESSURE SIGNAL	
			SRM (NO)	YES, NO
	INVERT INPUT (NO)	YES, NO	<input type="checkbox"/>	
	INPUT 2	INPUT 2 FUNCTION	DISABLED	
			IMMEDIATE SHTDN	
			DOOR OPEN ALARM	
			OVERLOAD	
			CTRL PWR RELAY	
			CTRL OUTPUT 1	<input type="checkbox"/>
			CTRL OUTPUT 2	
			SOLENOID VALVE	
			MAX PRESSURE SIGNAL	
			SRM (NO)	YES, NO
	INVERT INPUT (NO)	YES, NO	<input type="checkbox"/>	
	INPUT 3	FLOW SIGNAL	<input type="checkbox"/>	
		SRM (NO)	YES, NO	<input type="checkbox"/>
INVERT INPUT (NO)		YES, NO	<input type="checkbox"/>	
INPUT 4	MAX PRESSURE SIGNAL	<input type="checkbox"/>		
	SRM (NO)	YES, NO	<input type="checkbox"/>	
	INVERT INPUT (NO)	YES, NO	<input type="checkbox"/>	

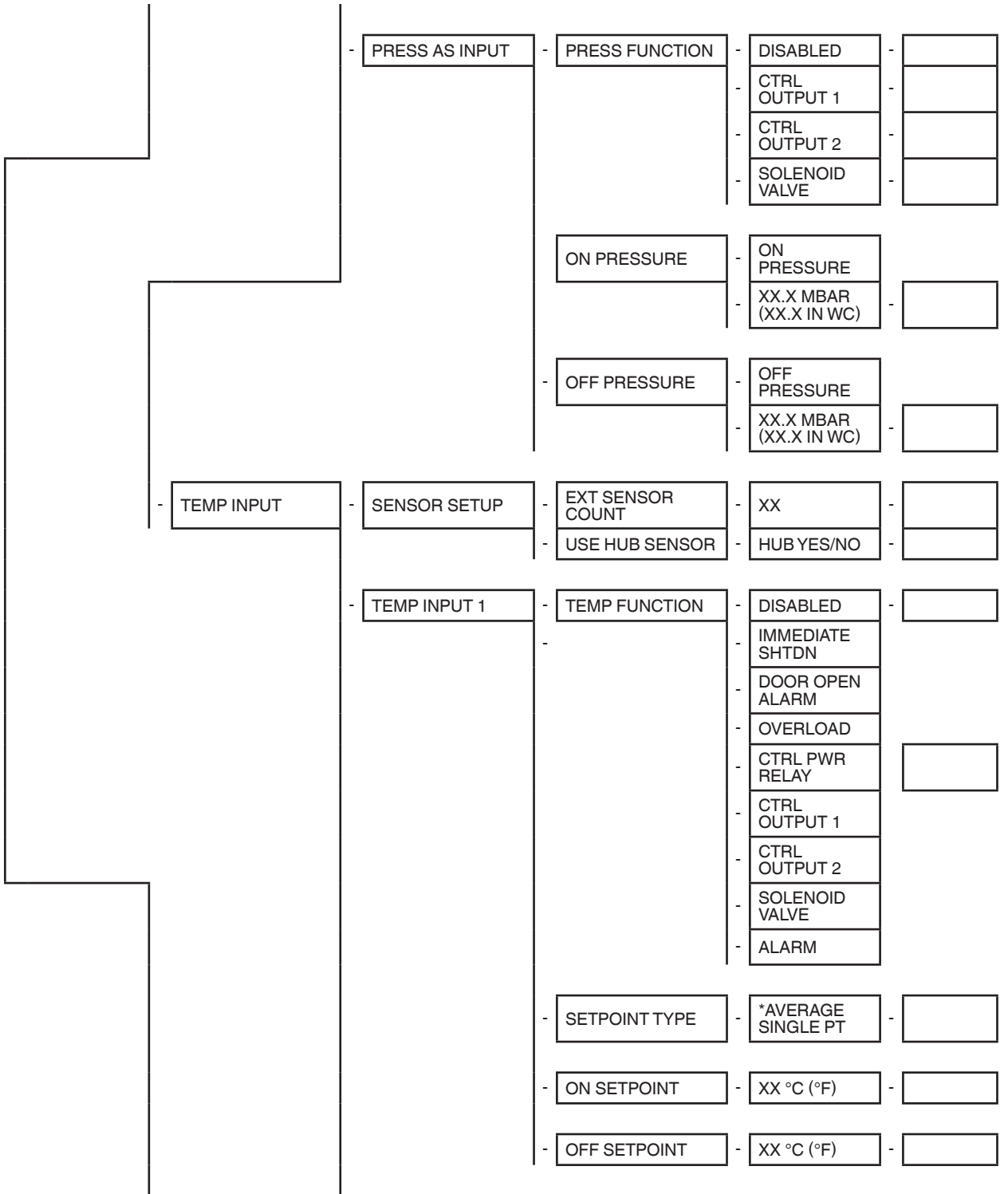



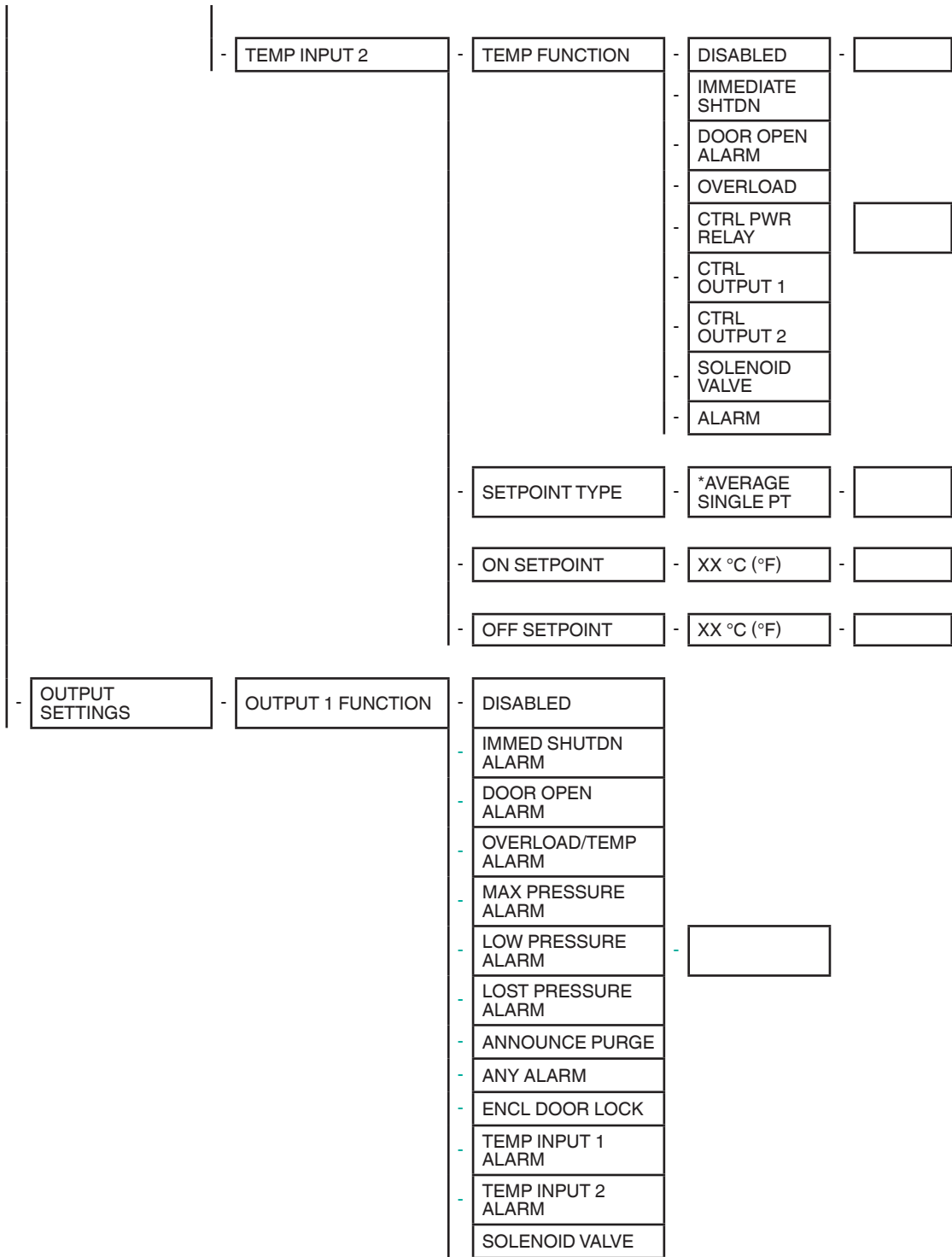

	OUTPUT 2 FUNCTION (DISABLED)	DISABLED		
		IMMED SHUTDN ALARM		
		DOOR OPEN ALARM		
		OVERLOAD/TEMP ALARM		
		MAX PRESSURE ALARM		
		LOW PRESSURE ALARM		
		LOST PRESSURE ALARM		
		ANNOUNCE PURGE		
		ANY ALARM		
		ENCL DOOR LOCK		
		SYSTEM BYPASS ALARM		
		TEMP INPUT 1 ALARM		
		TEMP INPUT 2 ALARM		
		SOLENOID VALVE		
PASSWORDS	CHANGE SETUP PSW	CREATE SETUP PASSWORD		
	CHANGE BYPASS PSW	ENTER BYPASS PASSWORD	CREATE BYPASS PASSWORD	
LANGUAGE (ENGLISH)	ENGLISH			
	DEUTSCH			
	ESPAÑOL			
	FRANCAIS			
BYPASS CONTROL	ENTER BYPASS PASSWORD	BYPASS ENABLE (NO)	NO, YES * FIXED/YES	
		BYPASS ON (NO)	OFF, ON	
FACTORY RESTORE	ENTER RESTORE PASSWORD	NO, YES		

ARROW KEY SEQUENCE - 4 TO 8 STROKES EACH

SETUP PASSWORD								
BYPASS PASSWORD								

DATE:

---

NAME:

---

# 5. Product Identification

## 5.1. Specific Conditions of Use

### Control Unit

- When the purge control unit is mounted to an enclosure, the complete unit shall be evaluated to the current revision of IEC/EN 60079-2 or NFPA 496 as applicable. See certificates and/or Declaration of Conformity for reference to relevant editions of these standards.
- The purge control unit has an operating temperature class of 135 °C (T4 temperature class). This temperature shall be considered when mounted to an enclosure.
- Intrinsically safe cables extending from the enclosure must be provided with at least 0.25 mm insulation thickness per conductive core to maintain segregation between intrinsically safe circuits.
- The cable entries may be used only in places where they are protected against the influence of mechanical danger.
- The non-metallic membrane touchpad and display is a potential electrostatic discharge hazard. Use only water damp cloth and allow to air dry for cleaning device. Do not use or install in high charge areas. See IEC 60079-32-1 for further information.
- In applications where a 6000-TEMP-XX I.S. temperature hub is used, it must be mounted in an enclosure that is at least IP54. Maintain separation of I.S. to non-I.S. wiring as required by local codes.
- Caution must be used when handling or cleaning products so there is no static charge buildup. Do not wipe off the 6000-TSEN-xx sensor with dry cloth or use in the presence of high charge generating processes such as ionizers or electrostatic equipment. See IEC 60079-32-1 for further information.
- The 6100 systems may also be provided with previously certified items (operators, cable glands, terminal box, etc.) as specified in the test reports.
- The equipment shall only be fitted with suitably certified cable entry devices and/or blanking plugs appropriate to the application.
- The control unit must be mounted via the mounting tabs that are shown in sections 3.4.1 and 3.4.2.

### I.S. Termination Board, DIN-Mounted: 6000-ISB-xx

- Only connect to the 6000 EPCU I.S. termination connection.
- All wiring to and from this board is for intrinsically safe connections and must be properly routed and managed per international, NEC, local codes, and applicable standards.



#### Note

The SRM (Sensor Resistor Module) is a simple apparatus that detects breaks or shorts in the wiring. It does not require third-party certification.

## EPV-6100 Enclosure Protection Vent

- The EPV has an operating temperature class of 135 °C (T4 temperature class). This temperature shall be considered when mounted to an enclosure.
- Cables use to connect the EPV must be provided with at least 0.25 mm insulation thickness per conductive core to maintain segregation between intrinsically safe circuits.
- Only EPV-6100 vents can be connected to any certified 6100 series control system.
- The EPV must be mounted via the mounting holes that are shown in Sections 2.5.3 and 2.5.4.

## 5.2. Applied Standards and Markings

**i**

### Note

See the certificates and/or the Declaration of Conformity for details on specific editions of the standards listed below.

#### IECEX and ATEX:

EN / IEC 60079-0  
 EN / IEC 60079-1  
 EN / IEC 60079-2  
 EN / IEC 60079-7  
 EN / IEC 60079-11

## 5.3. Type Codes

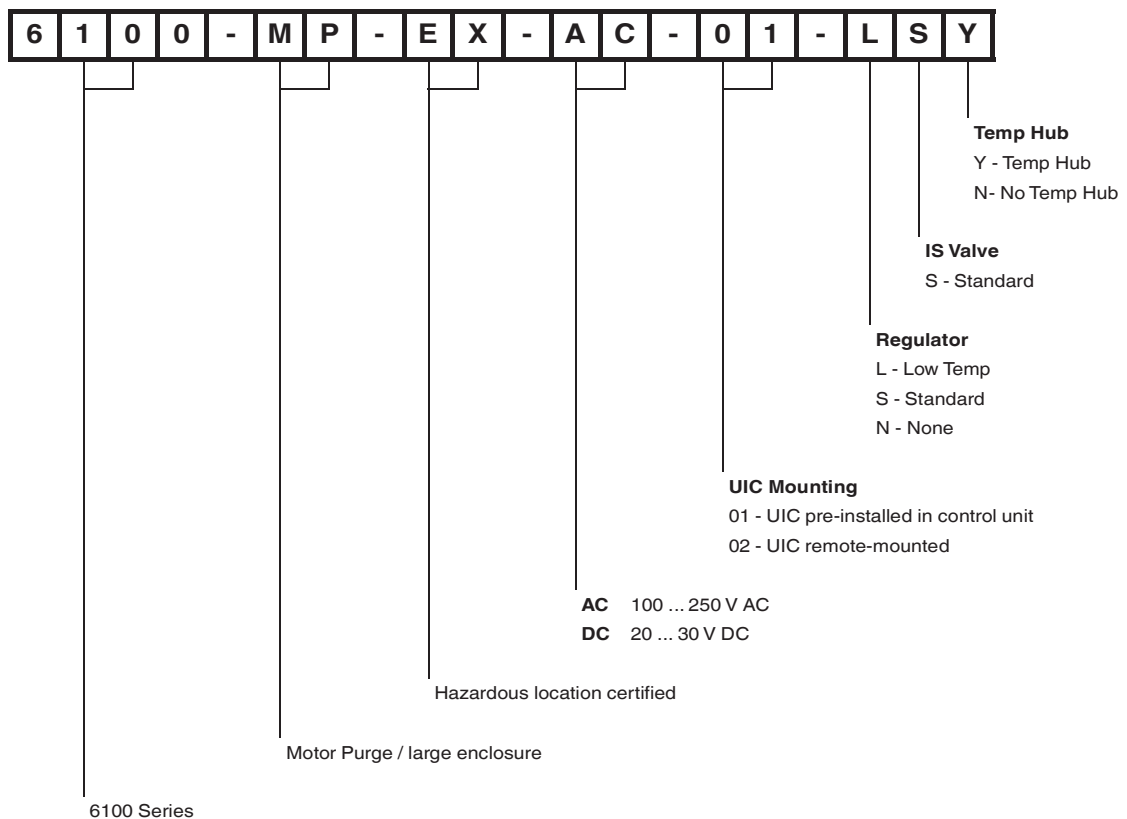

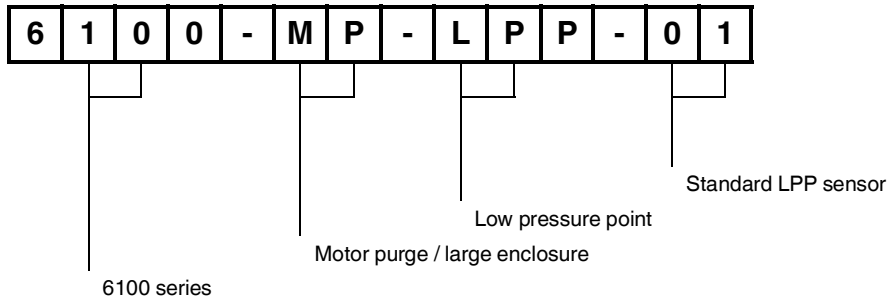
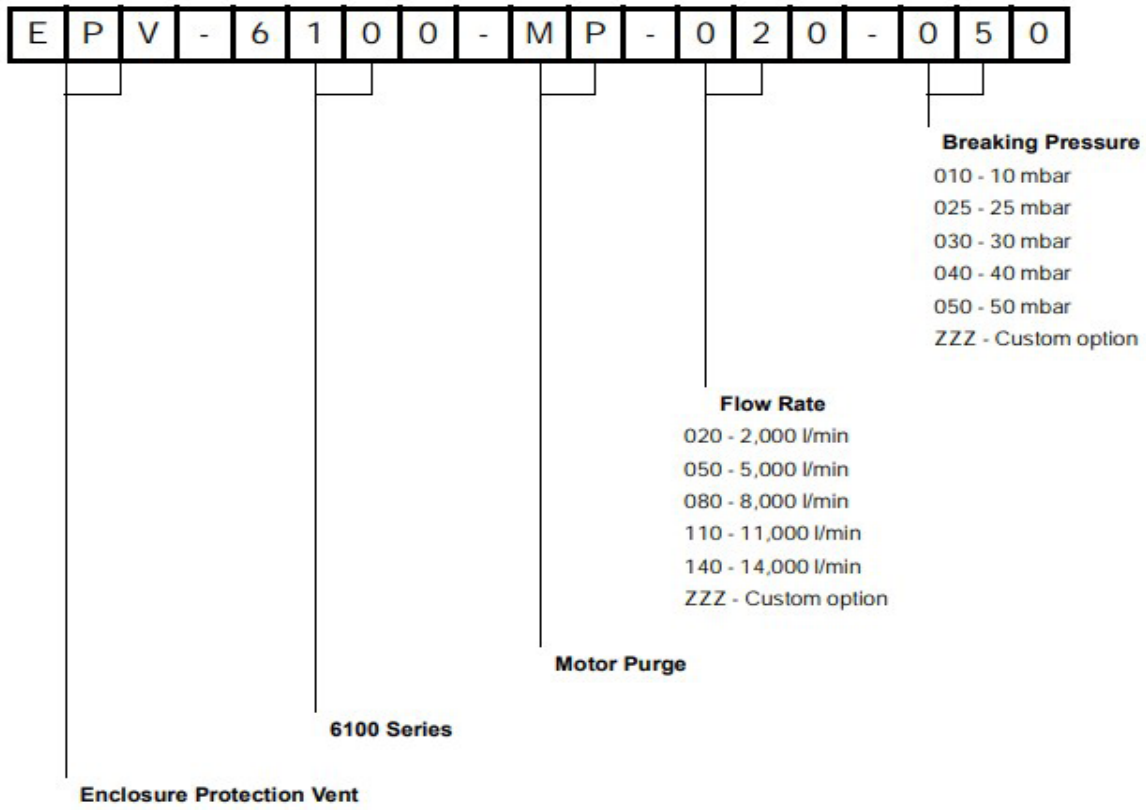

## 5.4. Labels and Markings

### Control Unit Label

**PEPPERL+FUCHS**  
68307 Mannheim, Germany    www.pepperl-fuchs.com

**Model: 6100-MP-EX-AC-01**

**CE** 0539    **Ex**    **UK**    **CA** 2503

II 2G Ex db eb ib [ib Gb] [pxb Gb] IIC T4 Gb  
IECEX CML 19.0156X  
CML 19 ATEX 1425X  
UKCA21UKEX2015X

IP66  
(-20°C ≤ Ta ≤ 60°C)

Supply voltage: 100 to 250V ~ , 0.1A  
- Warning - Non-intrinsically safe circuits protected by internal IP30 cover  
- See manual for other connection information  
- Consult Safety Instructions for repair instructions.

SERIAL:

ASSEMBLED IN USA BEBCO EPS®

### Vent Label

**PEPPERL+FUCHS**  
68307 Mannheim, Germany    www.pepperl-fuchs.com

**Model: #NAME#**

02060516838026

Part of IECEX CML 19.0156X  
Part of CML 19 ATEX 1425X  
Part of CML 21UKEX1380X

IP66

ASSEMBLED IN USA    (-20°C ≤ Ta ≤ 60°C)    **BEBCO EPS®**

### LPP Label

**PEPPERL+FUCHS**  
68307 Mannheim, Germany    www.pepperl-fuchs.com

**6100-MP-LPP-01**

Part of IECEX CML 19.0156X  
Part of CML 19 ATEX 1425X  
Part of CML 21UKEX1380X

(-20°C ≤ Ta ≤ 60°C)

ASSEMBLED IN USA    **BEBCO EPS®**

# 6. Product Lifetime Care

## 6.1. Maintenance and Repair

1. The 6100 purge and pressurization system does not require special maintenance except replacement of pneumatic filters, when used, and normal periodic functional checks, including pressure and flow readings within specifications contained in this manual. When checking whether the pressure and flow measurements of the EPV-6100 vent are within specifications, use calibrated equipment to determine measurements, or contact a Pepperl+Fuchs representative or the factory to send back the EPV-6100 vent for pressure and flow verification.
2. The purge and pressurization system, when operated in conjunction with a hazardous area, must not be modified. If there is a defect, the product may need to be replaced. Repairs must be performed only by a Pepperl+Fuchs specialist who is specifically trained and authorized to repair the defect.
3. Any replaceable fuses must be replaced with specific fuse ratings and type, as written in this manual under Specifications.
4. When servicing, installing, and commissioning, the area must be free of all combustible material and/or hazardous explosive gas. Only the terminal compartment of the control unit is accessible to the user. Not under any circumstances, shall the control unit, user-interface, or vent, be taken apart. The Ex d housing cover shall only be removed when power is removed from the device or the area is known to be safe.
5. Any cable glands that require replacement shall be replaced with the same model or another approved cable gland that meets the area classification.
6. When replacing the EPCU, the area must be free of hazardous gas and/or dust and power removed from the EPCU, enclosure contacts, and auxiliary contacts. Two screws on the bottom of the Ex d enclosure need to be loosened but not removed. Twist the EPCU clockwise and lift it out of the Ex d enclosure. Reverse to install new EPCU.

Contact Pepperl+Fuchs customer service for an RMA (Return Merchandise Authorization).

## 6.2. Troubleshooting Alarms and Fault Conditions

The 6100 purge controller can indicate certain alarm and fault conditions when they happen. The alarm condition is indicated on the display under the Alarm/Fault LED and will blink for an alarm and remain solid for a fault. The alarm will not disengage enclosure contacts if they are on but can be directed to the AUX alarm contact. The fault will disengage enclosure contacts.

Alarm	Description	Solution
NO SAFE PRESSURE	Enclosure pressure is below minimum safe pressure	-No purge supply -Enclosure leakage too great
MAX PRESSURE	Enclosure pressure is above the maximum pressure allowed	-Purge supply pressure too much -EPV-6100 vent is blocked or not installed -Max pressure signal input activated
LOW PRESSURE	Enclosure pressure is below the alarm pressure but above the min. safe pressure	-Purge supply capacity is not keeping up -Enclosure is starting to leak more
INPUT 1-4 BROKE/ SHORT	When SRM is selected, then a wire is broken or shorted going to the switch input	-SRM is selected and not installed on the switch input -Broken or shorted wire to switch/SRM
DOOR OPEN	Causes the purge system to reset and will not start again until clear	- Signal from switch input activated door open -Shorted wire going to switch input with no SRM selected
IMMEDIATE SHUTDOWN	Causes the purge system to reset and will not start again until clear	-Signal from switch input activated immediate shutdown -Shorted wire going to switch input with no SRM selected
OVERLOAD SHUTDOWN	Does not reset purge system but can sound an alarm	-Signal from switch input activated immediate shutdown -Shorted wire going to switch input with no SRM selected
LOST FLOW	During purging, if EPV-6100 vent detects a flow lower than expected, alarm is activated	-Signal from switch input activated immediate shutdown -Shorted wire going to switch input with no SRM selected TEMP INPUT 2
13V	Power to internal bus is too low for components to operate properly	-Defective EPCU
9.5V	Power to the I.S. comm bus for vent, UIC, Temp Hub is too low for proper operation	-Defective EPCU -I.S. barrier board fuse is blown
TEMP INPUT 1	Temperature Input 1 is active	-The temperature of the Temp Hub or Temp sensor is outside the limits
TEMP INPUT 2	Temperature Input 2 is active	-The temperature of the Temp Hub or Temp sensor is outside the limits
ENCLOSURE POWER RELAY	Monitor circuit detects relay malfunctioned	-One of the contacts are welded shut



CONTROL VALVE	The control valve circuit is not functioning properly	-I.S. barrier board fuse is blown -Power supply to control unit is too low
INPUT 1-4	Input 1 ,2, 3, or 4 is not functioning properly	-I.S. barrier for inputs has blown fuse -EPCU defective
FLOW READING	Flow reading from EPV-6100 vent is corrupted or not available	-Flow readings are outside the range of the EPV-6100 vent being used
CONFIG STORAGE	Memory location corrupted	EPCU is defective
610-LPP UPDATE	6100-LPP is not communicating	No LPP is connected, or LPP is misconnected
CRC MISMATCH	Both of the EPCU processors instruction set are not in sync	EPCU is defective
EPV-6100 FLOW UPDATE	EPV-6100 vent is getting power but communication is not correct	One or more of the connections is not correct EPV-6100 is defective
TEMPERATURE UPDATE	The Temp Hub/Temp Sensor reading is out of the specification or not reading	Connections could be incorrect Not set up properly in the menu structure of the EPCU
INTERNAL RAM	EPCU memory fault	EPCU is defective
9.5V	Power to the I.S. comm bus for vent, UIC, Temp Hub is too low for proper operation	Defective EPCU I.S. barrier board fuse is blown
TEMP INPUT 1	Temperature Input 1 is active	The temperature of the Temp Hub or Temp Sensor is outside the limits
TEMP INPUT 2	Temperature Input 2 is active	The temperature of the Temp Hub or Temp Sensor is outside the limits
ENCLOSURE POWER RELAY	Monitor circuit detects relay malfunctioned	One of the contacts is welded shut

## 6.3. Dismantling and Decommissioning

Abide by all local and any other code requirements for disposing of electronic equipment. When disposing of any component of the 6100 system, VOID must be marked

# Your automation, our passion.

## Explosion Protection

- Intrinsic Safety Barriers
- Signal Conditioners
- FieldConnex® Fieldbus
- Remote I/O Systems
- Electrical Ex Equipment
- Purge and Pressurization
- Industrial HMI
- Mobile Computing and Communications
- HART Interface Solutions
- Surge Protection
- Wireless Solutions
- Level Measurement

## Industrial Sensors

- Proximity Sensors
- Photoelectric Sensors
- Industrial Vision
- Ultrasonic Sensors
- Rotary Encoders
- Positioning Systems
- Inclination and Acceleration Sensors
- Fieldbus Modules
- AS-Interface
- Identification Systems
- Displays and Signal Processing
- Connectivity

### Pepperl+Fuchs Quality

Download our latest policy here:

[www.pepperl-fuchs.com/quality](http://www.pepperl-fuchs.com/quality)

