

6500 Purge System User Manual

Type Ex px Purge and Pressurization System



Your automation, our passion.

 **PEPPERL+FUCHS**

With regard to the supply of products, the current issue of the following document is applicable:
The General Terms of Delivery for Products and Services of the Electrical Industry, published by the
Central Association of the Electrical Industry (Zentralverband Elektrotechnik und Elektroindustrie
(ZVEI) e.V.) in its most recent version as well as the supplementary clause: “Expanded reservation of
proprietorship”.

Worldwide

Pepperl+Fuchs Group
Lilienthalstr. 200
68307 Mannheim
Germany

Phone: +49 621 776 - 0
E-mail: info@de.pepperl-fuchs.com

North American Headquarters

Pepperl+Fuchs Inc.
1600 Enterprise Parkway
Twinsburg, Ohio 44087
USA

Phone: +1 330 425-3555
E-mail: sales@us.pepperl-fuchs.com

Asia Headquarters

Pepperl+Fuchs Pte. Ltd.
P+F Building
18 Ayer Rajah Crescent
Singapore 139942

Phone: +65 6779-9091
E-mail: sales@sg.pepperl-fuchs.com
<https://www.pepperl-fuchs.com>

Table of contents

1. Introduction.....	5
1.1. Content of this Document	5
1.2. Target Group, Personnel.....	6
1.3. Symbols Used.....	7
1.4. Pertinent Laws, Standards, Directives, and Further Documentation.....	8
1.5. Declaration of Conformity.....	8
2. Product Description	9
2.1. Introduction	9
2.2. 6500 System Overview	10
2.2.1 Standard vs. Dilution Applications	10
2.2.2 System Components	11
2.3. 6500 Control Unit	12
2.3.1 Technical Data: Control Unit	13
2.3.2 Electrical connections	18
2.3.3 Dimensions	20
2.4. Mounting of the control unit.....	24
2.5. EPV-6500 pressure relief vent.....	27
2.5.1 Technical Data: Vent	28
2.5.2 Electrical connections	30
2.6. Dimensions	31
2.6.1 Flow rate curves	32
2.7. Manifold valves	35
2.7.1 6500-MAN-DV	35
2.7.2 Technical Data.....	35
2.7.3 6500-MAN-PV	35
2.8. Cable glands (6500-CBLG...)	36
3. Installation and Operation	37
3.1. Installation.....	37
3.1.1 For Gas Atmospheres	37
3.1.2 For Dust Atmospheres.....	38
3.1.3 For Dust and Gas Atmospheres	38
3.1.4 Dilution Applications.....	38

- 3.2. Before Setup 41
 - 3.2.1 Setup procedures for standard applications 43
- 3.3. Operation for standard applications 44
- 3.4. Sequence of Events 45
 - 3.4.1 Energizing enclosure power 45
 - 3.4.2 De-energizing enclosure power 46
- 4. Programming 47**
 - 4.1. User Interface 47
- 5. Statistics..... 57**
- 6. Product Identification 60**
 - 6.1. Specific Conditions of Use 60
 - 6.2. Applied Standards 61
 - 6.3. Type Codes 61
 - 6.4. Markings (Labelling) 62
 - 6.4.1 CCC Certification Markings 63
- 7. Product Lifetime Care 64**
 - 7.1. Maintenance and Repair 64
 - 7.2. Troubleshooting..... 64
 - 7.3. Dismantling and Decommissioning..... 66

1. Introduction

1.1. Content of this Document

This document contains information required to meet the safety and protection requirements for systems when installing, commissioning, and using the 6500 control unit and its components. This important information will help you use the 6500 purge and pressurization system safely and correctly.

This may include information on the following:

- Product identification
- Delivery, transport, and storage
- Mounting and installation
- Commissioning and operation
- Maintenance and repair
- Troubleshooting
- Disposal

Knowledge of the basic safety regulations and additional training and experience in the area of explosion protection are essential for the safe handling and failure-free operation of the 6500 series purge and pressurization system.

These operating instructions contain important data and information to ensure the safe use of the 6500 system in hazardous areas and to meet the requirements of Directive 2014/34/EU. This manual, particularly the safety information, must be followed by all personnel who work on the system.



WARNING!

Failure to follow these instructions may impair the safety protection and function of the equipment.



Note

For complete information on this product, see further documentation at www.pepperl-fuchs.com.

Information about individual components can be provided on request.

The documentation comprises the following parts:

- This document
- Safety instruction manual
- Datasheet

In addition, the documentation may comprise the following parts, if applicable:

- Manufacturer declaration of conformity
- EU declaration of conformity
- Additional documents

1.2. Target Group, Personnel

Responsibility for planning, assembly, commissioning, operation, maintenance, and dismantling of the 6500 series lies with the plant operator. Personnel working on this system must:

- be familiar with the occupational safety and accident prevention regulations and have been briefed regarding handling of the unit.
- have the additional knowledge of explosion protection that is required for work on explosion-protected components.
- be familiar with the relevant rules and regulations for the installation, operation, and maintenance of explosion-protected systems.
- have read the safety section and warnings in this manual.

1.3. Symbols Used

This document contains symbols to identify warning messages and information messages.

Warnings

You will always find warning messages whenever hazards could result from your actions. It is essential that you observe these warning messages to ensure your personal safety and to prevent property damage.

Warning messages are shown in descending order according to the risk level, as follows:



DANGER!

This symbol warns you of an immediate and present danger.

If you do not observe this warning message, there is a risk of personal injury and even death.



WARNING!

This symbol warns you of a potential fault or hazard.

If you do not observe this warning message, there is a risk of personal injury or severe property damage.



CAUTION!

This symbol warns you of a potential fault.

Failure to observe this warning message may result in the malfunctioning or complete failure of the product or any systems and plants connected to it.

Information Symbols



Note

This symbol draws your attention to important information.



Action instructions

This symbol highlights an action. You are prompted to perform an action or sequence of actions.

1.4. Pertinent Laws, Standards, Directives, and Further Documentation

NEC, CEC, and other national and local laws, standards, or Directives that are applicable to the intended use and installation location must be observed. In relation to hazardous areas, Directive 1999/92/EC must be observed.

The corresponding datasheets, EU Declaration of Conformity, EU Type Examination Certificates, NEC/NFPA and CEC certificates, and control drawings, if applicable (see datasheet), are an integral part of this document. You can find this information at www.pepperl-fuchs.com.

Due to constant revisions, documentation is always subject to change. Please refer only to the most up-to-date version, which can be found at www.pepperl-fuchs.com.

1.5. Declaration of Conformity

All products were developed and manufactured under observance of the applicable European standards and guidelines.

i

Note

A Declaration of Conformity is included with these instructions and can be requested from the manufacturer or obtained online at www.pepperl-fuchs.com. Additional documentation can also be provided for individual components.

The product manufacturer, the Pepperl+Fuchs Group, 68307 Mannheim, has a certified quality assurance system that conforms to ISO 9001.



2. Product Description

2.1. Introduction

Purge and pressurization is one of the most versatile ignition protection classes. Purge and pressurization systems are based on the principle that in Zone 1 (gas), the gas mixture in the ambient atmosphere, which may ignite under certain circumstances, is removed from the housing by an initial purge process. After the purge phase, sufficiently compressed inert gas, usually air, is supplied to compensate for leaks in the housing and any installed equipment. This permanent overpressure prevents any potentially explosive atmosphere in the ambient air from entering the housing. During the pressurization phase, an internal pressure is achieved.

Any hot spots that may occur on individual components in the control cabinet are monitored by temperature sensors (optional) and switched off safely if necessary. This ensures that no unacceptably high surface temperatures can reach the exterior.

For applications in Zone 21 (dust), the purge process is omitted because purging would raise explosive dust into a cloud, creating a possible hazard. Instead of pre-purging, the interior of the housing is inspected for dust and cleaned manually if dust is present.

When dealing with containment systems and dilution applications, refer to the applicable standards for the requirements. In some cases, dilution with compressed air is not possible and nitrogen or some other type of inert gas is required.



Note

When using an inert gas like nitrogen, an asphyxiation hazard can exist. The purge and pressurizing system is particularly suitable for installed equipment that is not approved for use in hazardous areas. It can then be used in the hazardous area when properly installed.



Note

EN 60079-2 and IEC 60079-2 do not cover both gas- and dust-hazardous atmospheres. The 6500 system provides a solution for both at the same time but this must be evaluated by the certification bodies for approval.

2.2. 6500 System Overview

The Pepperl+Fuchs 6500 purge and pressurization controller allows for general purpose equipment to operate in a Zone 1/21 hazardous area to achieve an Ex px rating, or Zone 2/22 rated equipment mounted in an enclosure in a Zone 1/21 hazardous area to achieve an Ex py rating. The 6500 control unit and EPV-6500 vent is certified for Ex px or Ex py applications.



2.2.1 Standard vs. Dilution Applications

The 6500 purge and pressurization system can be set up for standard or dilution applications. Standard applications are pressurizing enclosures that have equipment within the pressurized enclosure that does not contain any hazardous gas.

Dilution applications are enclosure systems that do not have a containment system within the enclosure. Containment systems in this context are usually used in analyzer applications where a small stream of hazardous gas enters the pressurized enclosure and is analyzed for its content. This containment (within the pressurized enclosure) is the piping, enclosure, and any other device that can hold the hazardous gas, which has the potential to leak within the enclosure. The leakage rate and the leak potential will determine the type of purging required and the equipment needed.



Note

If the leakage rate cannot be determined or it is unlimited, then inert gas is required and dilution cannot be used.

2.2.2 System Components

The 6500 purge and pressurization system consists of the following devices:

6500 control unit

The control unit provides all the functions, including user-defined functions. The 6500 controls the actions for the system and supplies the supporting devices.



EPV-6500 vent

The EPV-6500 vent provides pressure relief to the pressurized enclosure and feedback to the 6500 control unit with pressure and flow information.

The EPV-6500 vent is intrinsically safe with I.S. power and signal protection from the 6500 control unit. There are two styles of vent available: one for standard applications and one for dilution applications.

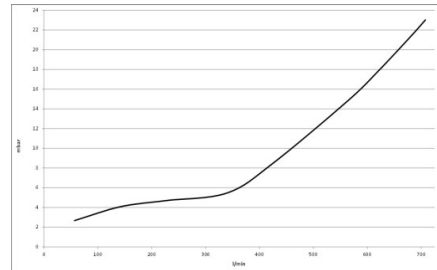

6500-MAN-DV manifold system

The 6500-MAN manifold has a digital valve that is activated by the 6500 control system for purging and cooling and pressure control. It is intrinsically safe and has a needle valve for adjusting the pressure in the enclosure during the pressurization phase.

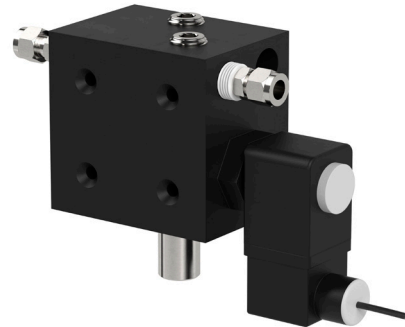

WARNING!

When using other customer-provided electrical valves, please follow the entity parameters of the valve and the output of the 6500 control unit.

6500-MAN-PV proportional valve

This valve is used for dilution applications when the EPV-6500 continuous vent is used. It can also be used for standard applications. The EPV-6500-MAN-PV is activated by the 6500 control system and is intrinsically safe.



WARNING!

When using other customer-provided electrical valves, please follow the entity parameters of the valve and the output of the 6500 control unit.

6500-CBLG cable glands

The 6500 control system does not come with cable glands. Customers can supply their own approved cable glands or order the power and I.S. cable glands from Pepperl+Fuchs.



WARNING!

When using other customer-provided cable glands, check for the required certification and installation of selected cable glands for proper installation.

2.3. 6500 Control Unit

The 6500 control unit is the control center of the pressurized system and is suitable for Zone 1 and 21, Ex pxb and Ex pyb applications. The 6500 control unit can be ordered for different mounting configurations for different applications. This unit does not come with cable glands, which allows customers to select the type or brand of cable glands to use, but they must be approved for the area and application. Approved cable glands are available through Pepperl+Fuchs.



The features of the 6500 control unit are:

- User-selectable for pxb or pyb applications
- User-interface is intrinsically safe touch that can be ordered for remote mounting
- Universal power requirement, 20 ... 30 VDC / 100 ... 240 VAC
- 316L stainless steel housing with IP66 ratings
- External, internal, and UIC remote mounting options
- Input for 2-wire PT100 RTD for automatic temperature control/monitoring
- Automatic pressure control
 - Digital manifold with min./max. setpoints for pressurization
 - Proportional valve using user-configured setpoints
- Automatic flow control for dilution applications with the proportional valve and EPV-6500 continuous vent
- User-selectable input functions
 - Door switch (for immediate shutdown)
 - Bypass control with maintenance or commissioning selections
 - Enclosure contacts
 - Auxiliary contacts for alarms, low/max pressures, control valve
- RS485 com port w/HART protocol available through PACTware or other AMS systems, DTM/MDD/EDDLs available
- Bluetooth connectivity with APP programs available

2.3.1 Technical Data: Control Unit

Item	Value
General Specifications	
Operating mode	User-programmable
Number of volume exchanges	5 to 19
Minimum purge time	2 minutes
Hazardous environment	Gas, dust, gas and dust Note: gas and dust (combined) are not covered by the 60079-2 standard
Electrical Specifications	
Supply	
Rated power requirement	Universal AC/DC power requirement 100 ... 240 V AC $\pm 10\%$ / 50 ... 60 Hz / 200 mA 20 ... 30 V DC $\pm 10\%$ / 600 mA Um = 250 V Overvoltage category II
Connections	
EPCU	Terminal blocks and grounding screw

UIC	4-pin micro connector and cable (provided) For the 6500-01-PM02, cable length is 5 meters.
Input type	Intrinsically safe, maximum cable 60 meters at 50 pf/ft and 0.2μH/ft
Inputs	
Input I	Voltage-free contact or namur proximity sensor
Input type	Intrinsically safe Switch input (IS) U _o = 9.56 V I _o = 19.4 mA C _o = 3.6 μF L _o = 90 mH P _o = 46 mW
Input RTD	(1) 2-wire, PT100 RTD RTD input (IS) U _o = 5.88 V I _o = 3.38 mA C _o = 43 μF L _o = 100 mH P _o = 5 mW
Input type	Intrinsically safe, Ex ib
Output	
AUX output	
Output type	Voltage free contact outputs, SPDT configuration
Inrush current	2 A
Contact loading	2 A @ 240 VAC, resistive, 2 A @ 24 VDC Note: External fusing is required at 3 AC or DC / 1500 A breaking current, U _m = 250 V
Enclosure output	
Output type	Voltage free contact outputs, 2 N.O. configuration
Inrush current	8 A
Contact loading	8A @ 100 ... 250 VAC resistive to 60 °C 5A @ 100 ... 250 VAC resistive to 70 °C 8A @ 20 ... 30 VDC resistive to 60 °C 5A @ 20 ... 30 VDC resistive to 70 °C Note: External fusing is required at no more than 11 amps / 1500 A breaking current, U _m = 250 V
COM output	HART Com via RS485, DTM through PACTware, U _m = 250 V
Digital valve	
Internal resistance	280 Ω
Limit	Supply current Supply voltage Digital valve output (IS) U _o = 27.72 V I _o = 109 mA C _o = 84 nF L _o = 3 mH P _o = 756 mW

Open loop voltage	24 VDC
Proportional Valve	When used with the 6500-MAN-PV-01, intrinsically safe Proportional valve output (IS) $U_o = 19.11 \text{ V}$ $I_o = 70 \text{ mA}$ $C_o = 251 \text{ nF}$ $L_o = 7.2 \text{ mH}$ $P_o = 345 \text{ mW}$
Current	4 to 20 mA
Max load	300 Ω
Indicators	
LED indicators	<ul style="list-style-type: none"> • Safe pre-pressure / BLUE – safe enclosure pressure is achieved • Enclosure power / GREEN – enclosure power is on / RED – power is off • Rapid exchange / BLUE – rapid exchange is active • System bypass / AMBER – Warning, system bypass is active • Alarm / Fault / RED blinking – Alarm is detected / RED solid – fault is detected • Key / GREEN – a button on the capacitive touch display has been activated. Momentary indication.
Display	2x20 LCD for configuration, monitoring, and status of the 6500 system with back light and contrast selecting
Pneumatic parameters	
Protective gas supply	Instrument grade air or inert gas
Pressure requirement	For 6500-MAN-DV: 1.4 to 8.3 bar (20 to 120 psig) For 6500-MAN-PV: 3.5 to 6.9 bar (50 to 1000 psig) Note: Max pressure will depend on the vent model used.
Safe pressure	Gas: 0.82 mbar (0.33 in wc) Dust: 0.82 mbar (0.33 in wc) Gas+Dust: 0.82 mbar (0.33 in wc) Note: Gas+dust are not covered by the 60079-2 standard.
Valve flows	
EPV-6500-__-01, 03, 05	Standard vent series Readout on display from 56 to 850 l/min (2 to 30 scfm) in increments of 28 l/min (1 scfm). Minimum and maximum reading depend on type of vent and supply pressure. See datasheet for EPV-6500 series vent.
EPV-6500-__-07, 08	Continuous (dilution) vent series Readout on display is from 17 to 226 l/min (0.6 to 8 scfm) continuous reading. Maximum reading depends on type of vent and supply pressure. See datasheet for EPV-6500 series vent.
Communication output	RS485, (PACTware available)
Ambient conditions	
Ambient temperature	-20 °C ... +70 °C
Storage temperature	-40 °C ... +70 °C
Relative humidity	5 ... 85 %, noncondensing

Altitude	max. 2000 m
Vibration resistance	5 ... 100 Hz, 1g, 12 m/s ² , all axes
Impact resistance	30 g, 11 ms, all axes
Mechanical specifications	
Connection types	See mounting and cable gland requirements.
Degree of protection	IP66 (Device is protected against dust and strong jets of water.)
Pollution degree	Device can be installed in environments up to pollution degree 4.
Materials	
UIC display	Makrolon FI cover, A380 aluminum anodized casing
Housing	316L stainless steel
Hardware	316L stainless steel
Mass	Approximately 5.0 kg (11.0 lbs)
Cable gland requirements	For the 6500-CBLG requirements, please see data sheets available at www.pepperl-fuchs.com
I.S. cable glands	Requires (5) M12 approved cable glands (See accessories section for approved cable glands.)
Power cable glands	Requires (2) M16 and (2) M12 approved cable glands (See accessories section for approved cable glands.)
Terminal connections requirements	
Grounding bonding wire	2.5 mm ²
Internal and external ground screw	Torque is 1.6 Nm (14 in-lb). Wire should terminate under the screw with a ring or fork lug.
I.S. and power terminals	
Wire strip length	9 mm
Minimum wire strand in stranded wire	0.1 mm or greater
Type of wire	Copper only, rated at 90 °C
Tightening torque, min/max	0.4 Nm / 0.5 Nm
Conductor cross section solid min/max	0.2 mm ² / 2.5 mm ²
Conductor cross section stranded min/max	0.2 mm ² / 2.5 mm ²
Conductor cross section stranded with ferrule without plastic sleeve min/max	0.25 mm ² / 1.5 mm ²
Conductor cross section stranded with ferrule with plastic sleeve min/max	0.25 mm ² / 1.5 mm ²
Conductor cross section stranded AWG/kcmil min/max	24 / 14
Wire insulation	0.25 mm minimum thickness
2 conductors with same cross section, solid min/max	0.2 mm ² / 0.75 mm ²

2 conductors with same cross section, stranded min/max	0.2 mm ² / 0.75 mm ²
2 conductors with same cross section, stranded, ferrules without plastic sleeve min/max	0.25 mm ² / 0.34 mm ²



WARNING!

The intrinsic safety entities listed in the table above are subject to the following considerations.

The parameters are valid when one of the two conditions below is given:

- The total Li of the external circuit (excluding the cable) is < 1 % of the Lo value or
- The total Ci of the external circuit (excluding the cable) is < 1 % of the Co value.

The parameters are reduced by 50 % when both of the two conditions below are given:

- The total Li of the external circuit (excluding the cable) is > 1 % of the Lo value and
- The total Ci of the external circuit (excluding the cable) is > 1 % of the Co value.

6500 UIC cable connector

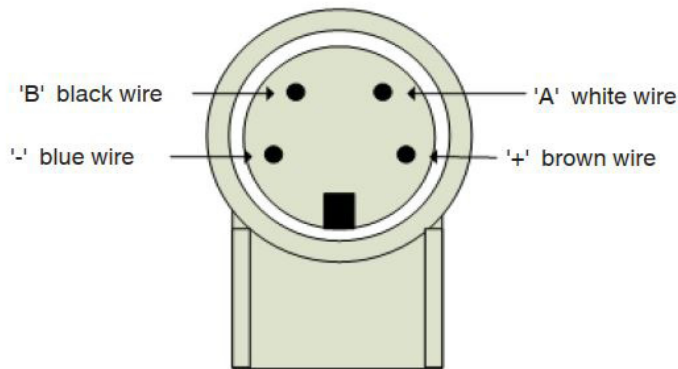

Male receptacle on UIC user interface
(Mating cable is included with 6500 control unit.)



Note

UIC connections are only to be connected to 6500-01-UIC_XX type user interface controller.



Note

Grounding points (internal and external) will be identified with a ground symbol.



WARNING!

The metal divider separating the I.S. and non-I.S. wiring terminals shall not be removed.

2.3.3 Dimensions

6500-01-EXT1-PNO-LNO External mount

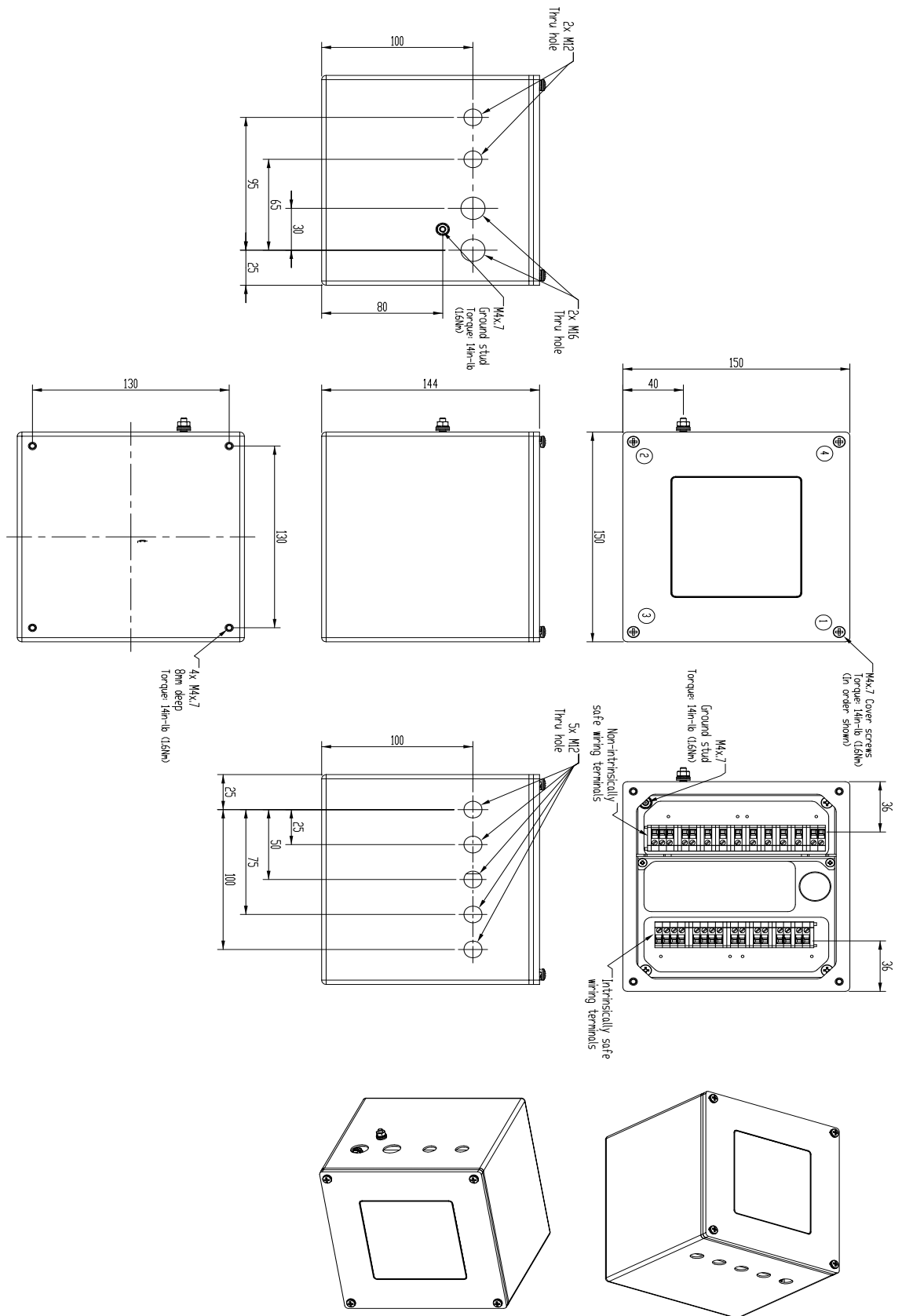

Dimension shown in mm (in).

6500-01-PM01-PNO-LNO Internal mount with UIC attached to EPCU

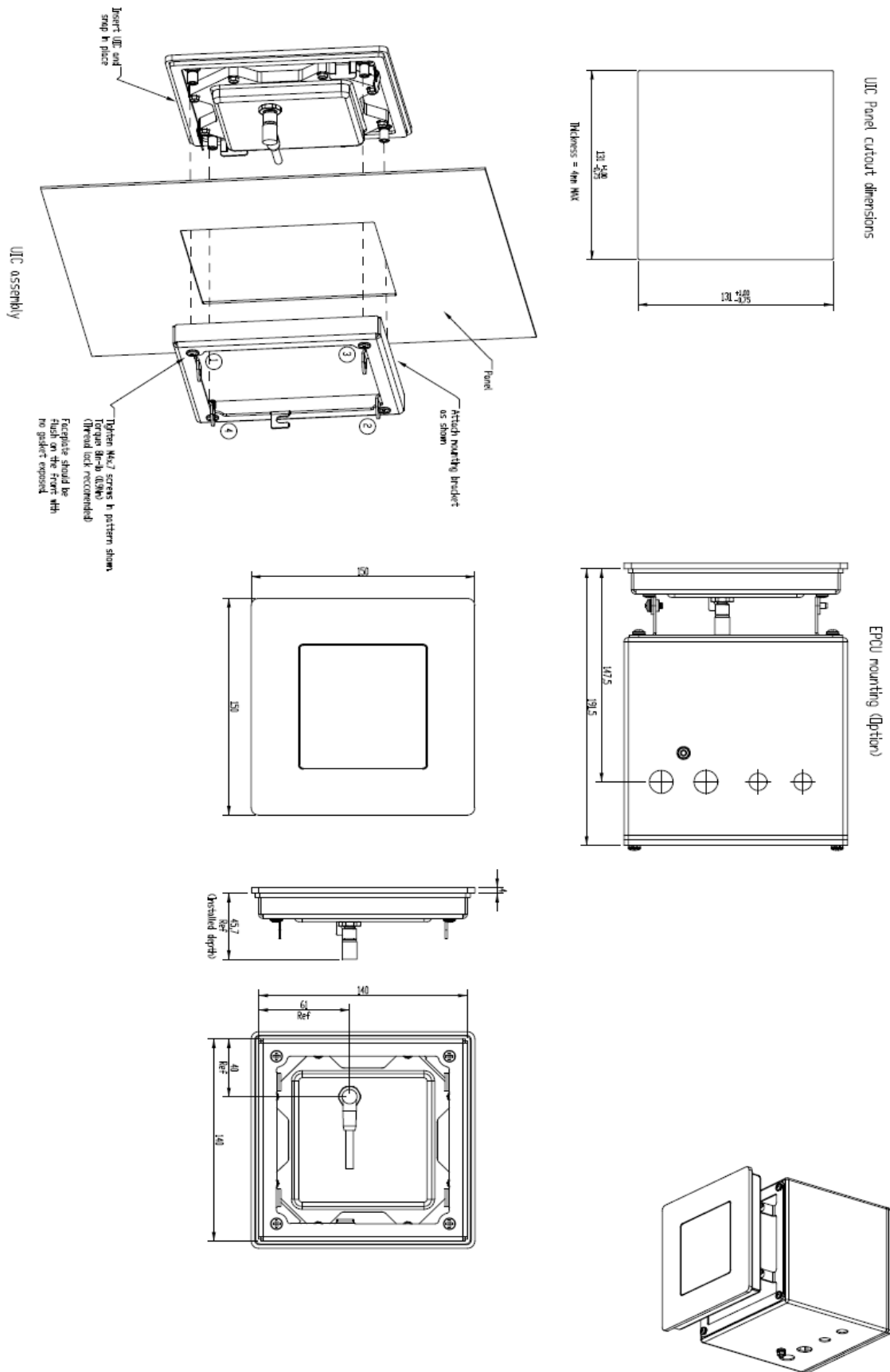

Dimension shown in mm (in).

6500-01-PM02-PNO-LNO Internal mount with UIC remote panel mount

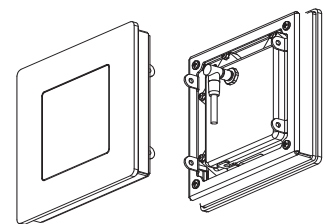
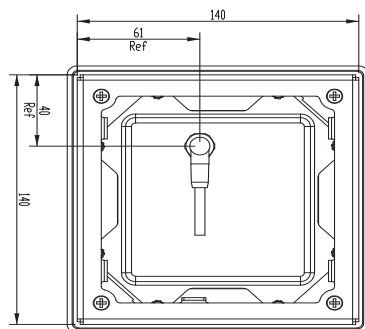
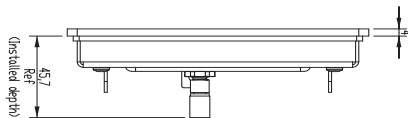
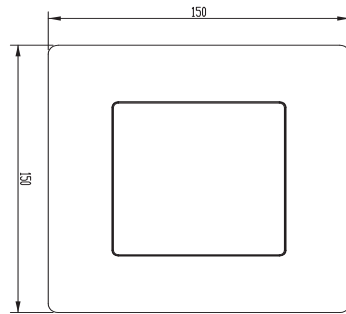
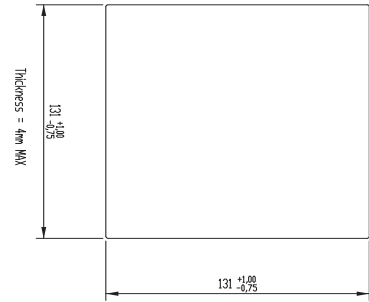
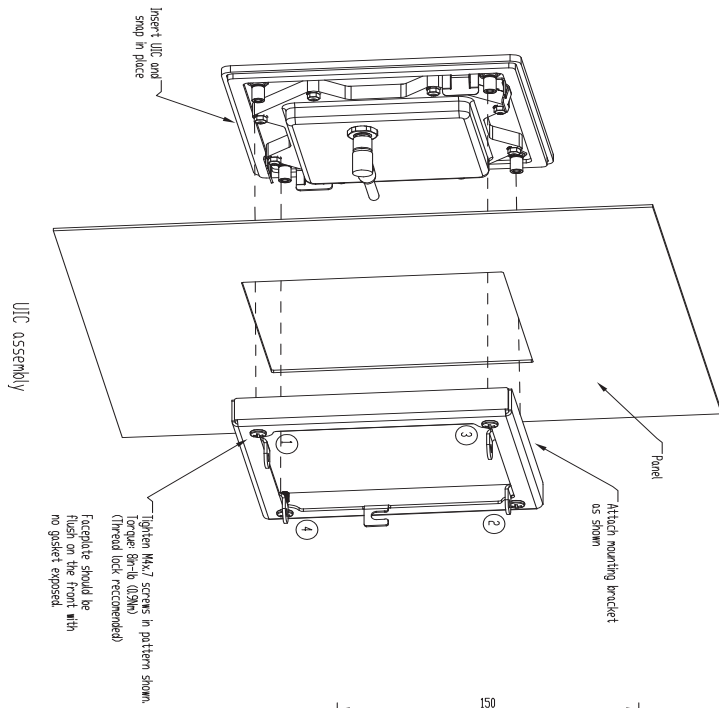

Dimension shown in mm (in).

6500-01-PM02-PNO-LNO Internal mount with UIC remote panel mount (cont'd)

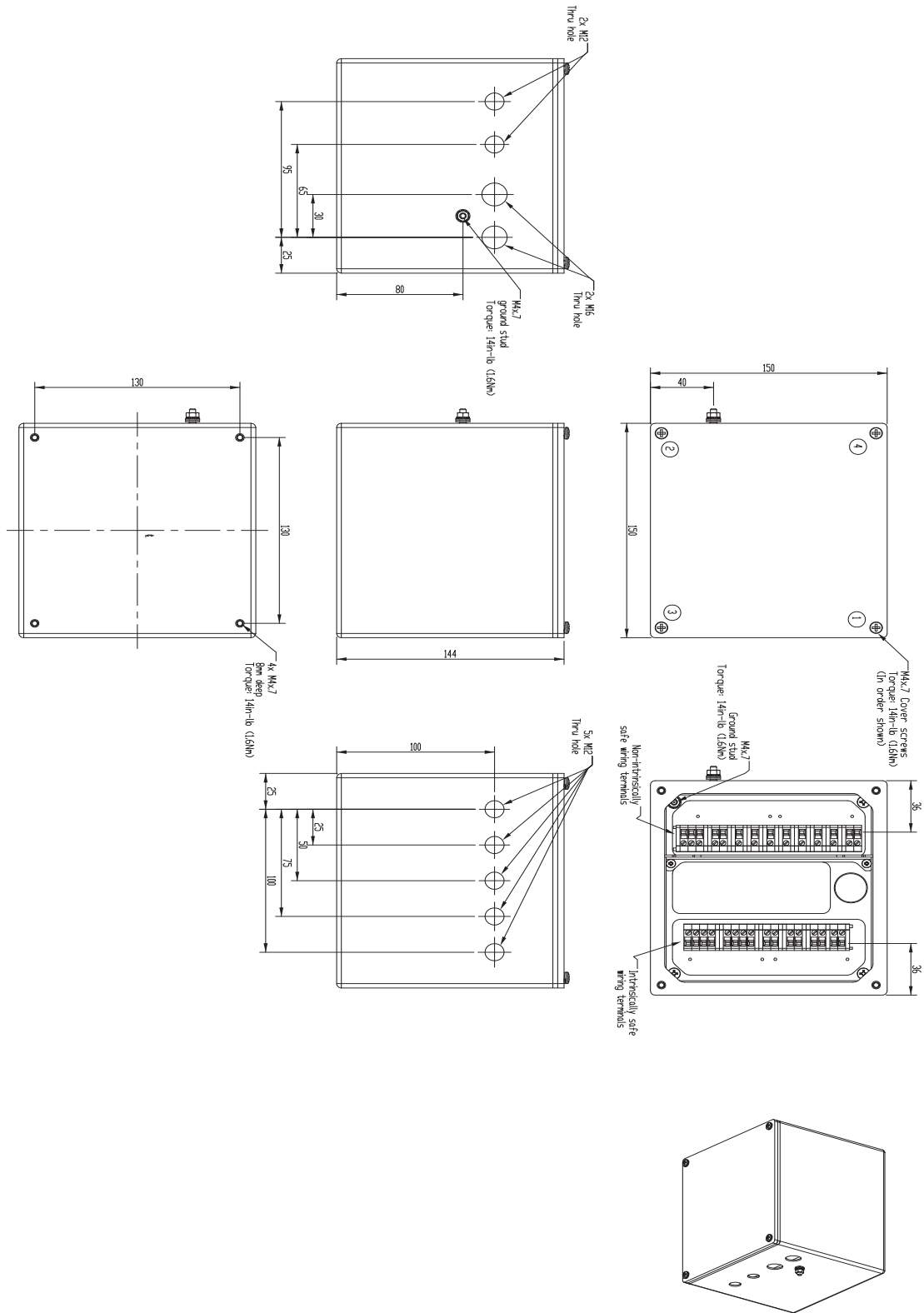

Dimension shown in mm (in).

2.4. Mounting of the control unit

Control unit flush mount

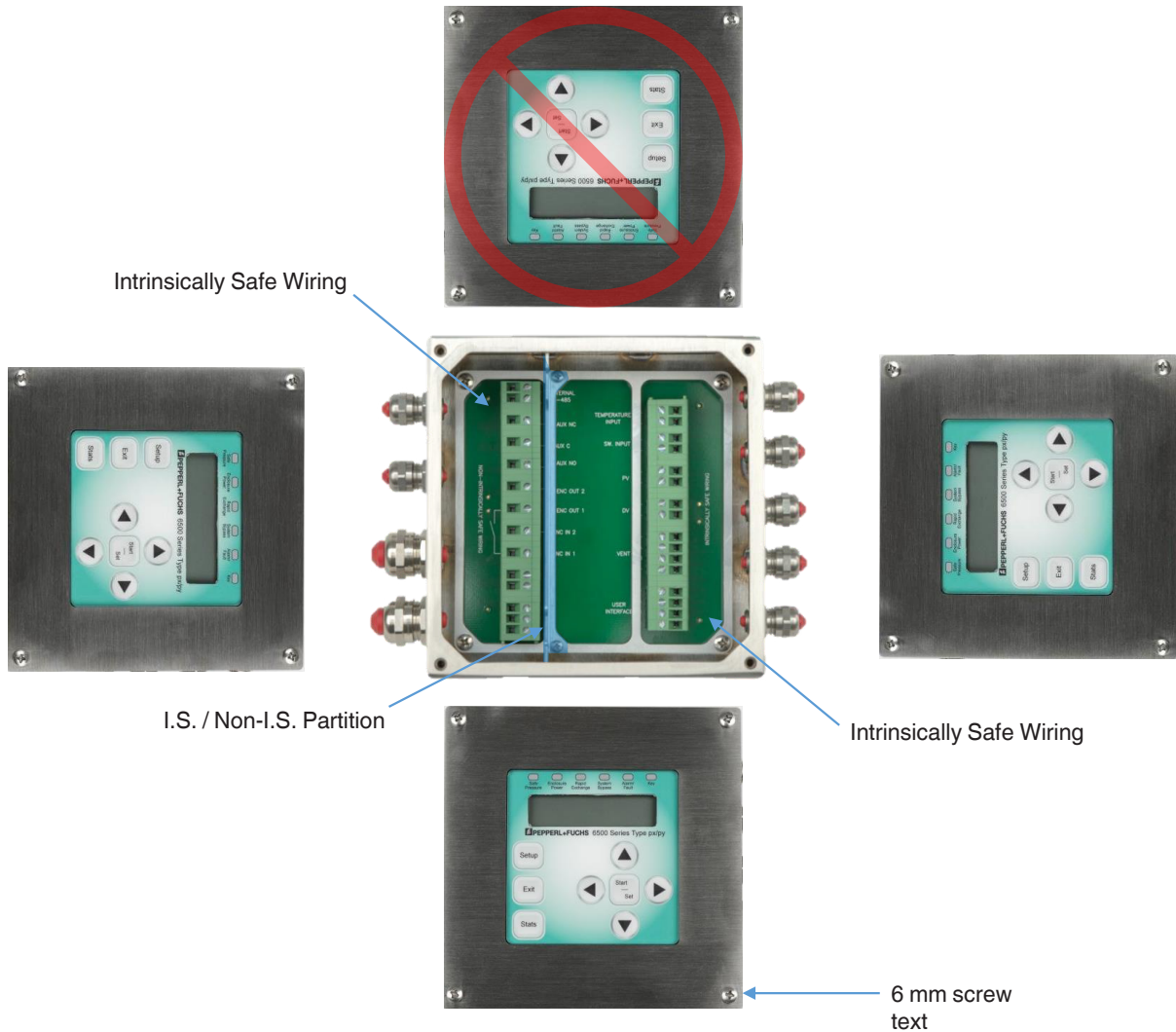

DANGER!

Display can be rotated $\pm 90^\circ$ as shown. Rotation of display is not permissible when the I.S. cable/connector of the UIC is directly over the non-I.S. wiring terminals.



WARNING!

6 mm screws and washers (4 included)
Torque specifications for UIC screws: 1.5 N6 (14 in lb)

UIC mounting: Side mount

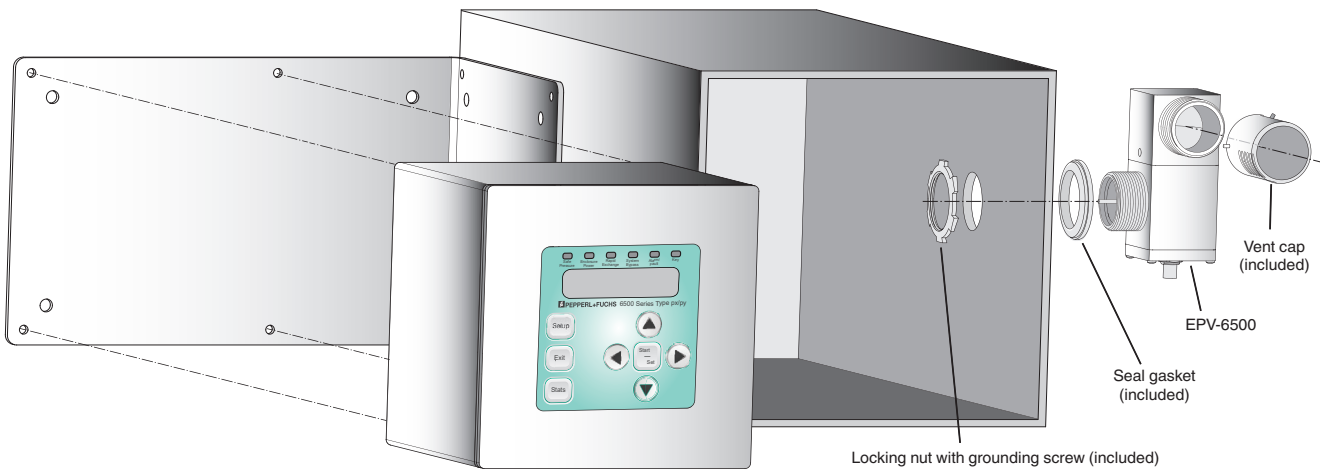

DANGER!

Unused cable entries will require a properly rated hazloc plug.

UIC mounting: Top mount

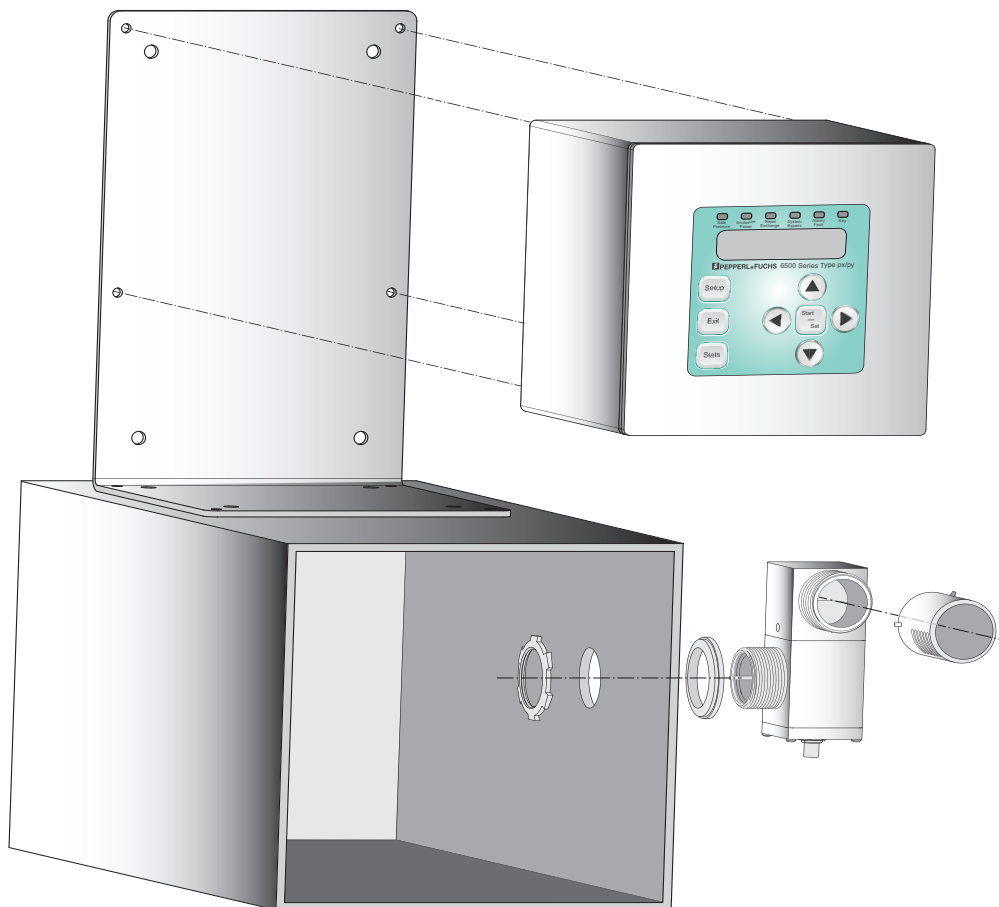

UIC mounting: PM01 internal mount

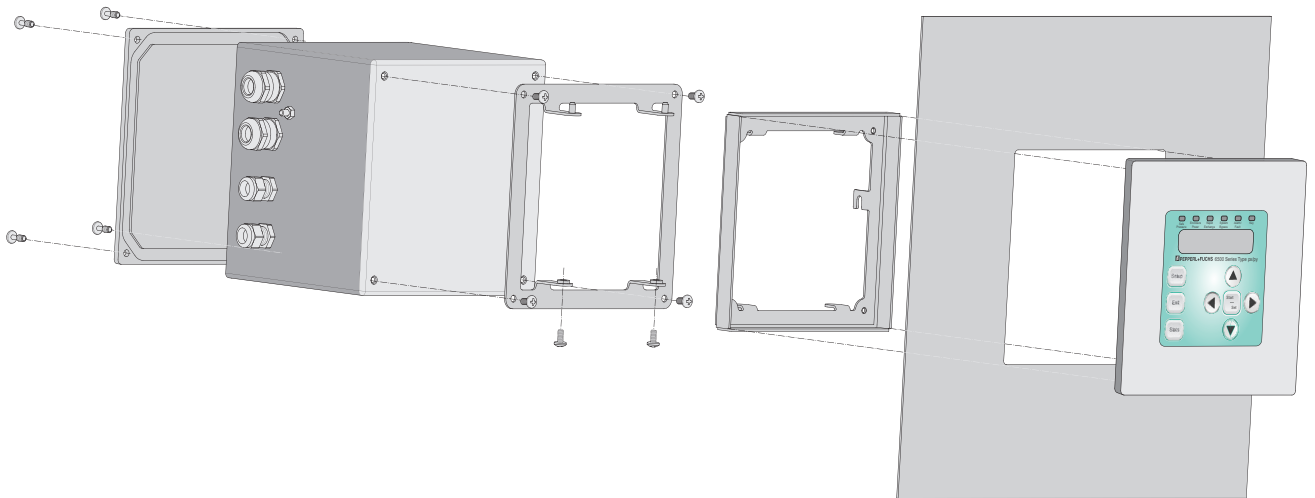

UIC mounting: PM02 component kit

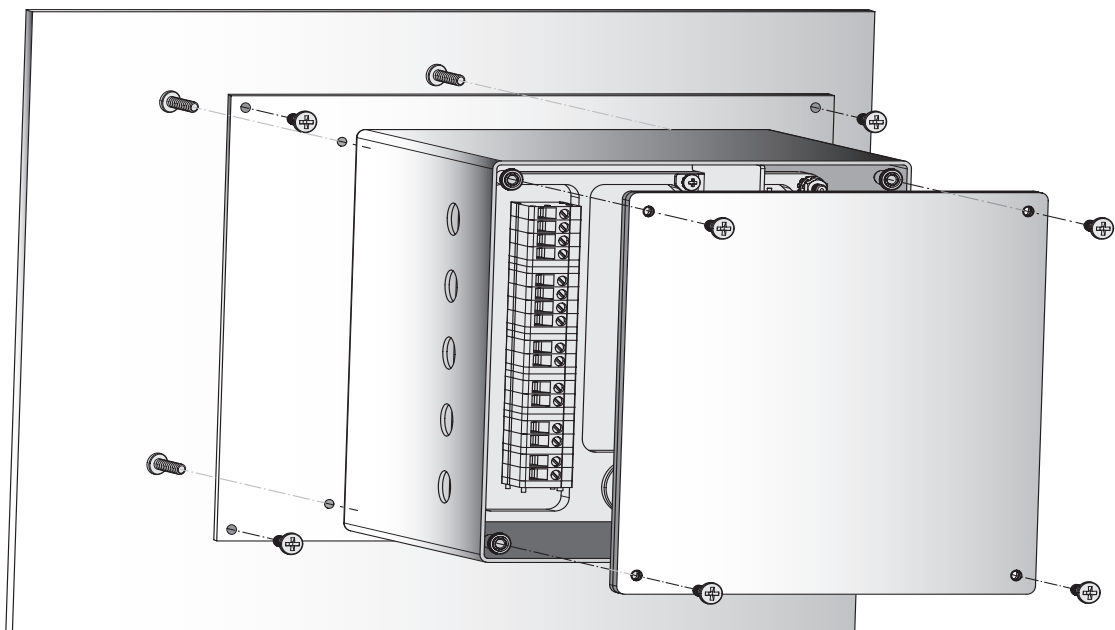

WARNING!

When mounting the 6500 control unit to a wall, the mounting method should be sturdy enough to support 4 times the gross weight of the 6500 control unit.

2.5. EPV-6500 pressure relief vent

The EPV-6500 vent is required for the 6500 control unit in order to provide a functional, certifiable purge and pressurization system for enclosures. As required by all pressurized enclosure systems, the EPV-6500 vent functions as a pressure relief device and allows the purge gas to exit the enclosure, yet provides a seal when the enclosure is pressurized below its pressure relief breaking pressure. The vent also has a spark arrestor as required for hazardous area operation. The EPV-6500 vent has a pressure sensor for measurement of enclosure pressure and a flow sensor for measuring purging flow and/or dilution flow through the exhaust of the vent. The two types of vents available are for standard applications (no containment system within the pressurized enclosure) and dilution applications (containment systems within the enclosure, i.e., analyzer applications) and each of these two groups have options suitable for different flows and purging pressures. All vents can be mounted externally or internally to the pressurized enclosure; they are not position-oriented. For internal mount only, the vent cap is exposed on the outside of the pressurized enclosure and the reference pressure connection to the vent has to be added for correct pressure and flow measurement. Connection fitting and tubing is included with the stainless steel cap version.



Standard Vents:

- EPV-6500-__-01: Normally used with large enclosures for shorter purge times. This vent allows the maximum flow through the enclosure for the minimum enclosure pressures. For large enclosures, this will keep the forces on the enclosure low while having the largest purge flow off all the EPV selections. The vent also has a higher leakage rate after purging (pressurization), but normally on large enclosures the leakage rate is much greater than the vent leakage and does not become a factor.
- EPV-6500-__-03: Normally used with medium or large enclosures where the leakage rate is critical and a short purging time is required. Because the seal is better than the '-01' model, the back pressure during purging will be higher; however, the leakage rate for pressurization is lower.
- EPV-6500-__-05: Gives the best seal for pressurization but highest back pressure for purging. These vents are extremely useful for bottled gas applications.

Dilution Vents:

- EPV-6500-__-07: The vent has a 8 mm diameter opening and requires a continuous flow to maintain pressure/flow. The flow is measured across this 8 mm orifice plate for greater accuracy.

When used with a proportional valve, like the 6500-MAN-PV, the control of flow is between 17 l/min (0.6 scfm) and 85 l/min (3 scfm).

- EPV-6500-__-08: The vent has a 16 mm diameter opening and requires a continuous flow to maintain pressure/flow. The flow is measured across this 16 mm orifice plate for greater accuracy.

When used with a proportional valve, like the 6500-MAN-PV, the control of flow is between 70 l/min (2.5 scfm) to around 226 l/min (8 scfm).

2.5.1 Technical Data: Vent

Item	Value
General Specifications	
Series	EPV-6500
Number of volume exchanges	05 to 19
Hazardous environment	Gas, dust, gas and dust
Electrical Specifications	
Supply	
Rated power requirement	Intrinsically safe when connected to the 6500 control unit
Signal	BUS back to the 6500 control unit (I.S.)
Connection	M12 connector, 4 pin Cable length: 5 m (provided)
Maximum cable length	60 meters at 50 pf/ft and 0.2 μ H/ft
Indicators	
LED indicators	Power: green
Pneumatic Parameters	
Safe pressure	Gas: 0.82 mbar (0.33 in. w.c.) Dust: 0.82 mbar (0.33 in. w.c.) Gas + Dust: 0.82 mbar (0.33 in. w.c.)
Vent pressure range	0 ... 25 mbar (0 ... 9.9 in. w.c.)
Vent Flows	
EPV-6500-__-01, 03, 05	Standard vent series Readout on display is from 56 to 850 l/min (2 to 30 scfm) in increments of 28 l/min (1 scfm). Minimum and maximum reading dependent on type of vent and supply pressure.

EPV-6500-__-07, 08	Continuous (dilution) vent series Readout on display is from 17 to 226 l/min (0.6 to 8 scfm) continuous reading. Maximum and minimum reading dependent on type of vent and supply pressure.
Purge flow rate / enclosure pressure	See graphs
Flow Rate for Leakage Compensation	
EPV-6500-__-01	Less than 9.9 l/min (0.35 scfm) @ 0.63 mbar (0.25 in. w.c.) Less than 27.3 l/min (0.97 scfm) @ 1.9 mbar (0.75 in. w.c.)
EPV-6500-__-03	Less than 6.6 l/min (0.23 scfm) @ 0.63 mbar (0.25 in. w.c.) Less than 16.0 l/min (0.57 scfm) @ 1.9 mbar (0.75 in. w.c.)
EPV-6500-__-05	Less than 1 l/min (0.35 scfm) @ 0.63 mbar (0.25 in. w.c.) Less than 1 l/min (0.35 scfm) @ 1.9 mbar (0.75 in. w.c.)
EPV-6500-__-07	N/A
EPV-6500-__-08	N/A
Breaking Pressure	
EPV-6500-__-01	2.0 mbar (0.8 in. w.c.)
EPV-6500-__-03	3.5 mbar (1.4 in. w.c.)
EPV-6500-__-05	3.8 mbar (1.5 in. w.c.)
EPV-6500-__-07	N/A
EPV-6500-__-08	N/A
Accuracy	
Pressure reading	
EPV-6500-__-01, 03, 05, 07, 08	
At 25 °C	± 0.025 mbar (± 0.01 in. w.c.)
Full temperature range	± 0.125 mbar (± 0.05 in. w.c.)
Flow reading	
EPV-6500-__-01, 03, 05	Standard vent, ± 28 l/min (± 1 scfm)
EPV-6500-__-07, 08	Continuous vent, ± 2.6 l/min (± .1 scfm)
Ambient Conditions	
Ambient temperature	-20 °C ... +70 °C
Storage temperature	-40 °C ... +70 °C
Relative humidity	5 ... 90 %, noncondensing
Vibration resistance	5 ... 100 Hz, 1g, 12 m/s ² , all axes
Impact resistance	30g, 11ms, all axes
Mechanical Specifications	
Degree of protection	IP66 rated sealing washer and electronics housing
Materials	

EPV-6500-AA-__	Body: marine grade 6061T6 anodized aluminum Cap: marine grade 5052 anodized aluminum
EPV-6500-SS-__	Body: marine grade 6061T6 anodized aluminum Cap: 316L (UNS S31603) stainless steel
Spark arrestor	304 stainless steel
Mass	Approx. 1.4 kg (3.1 lb)
Dimensions	127 x 146 x 83 mm (5.0" x 5.8" x 3.3")
Mounting	1½" NPT knockout (50.8 mm (2") hole) with seal nut included

2.5.2 Electrical connections

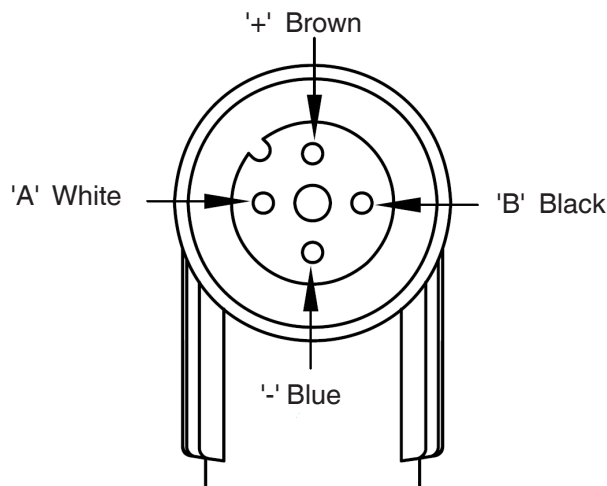

Male receptacle on EPV-6500 vent
(mating cable included with EPV-6500 vent)



Note

Vent connections are only to be connected to EPV-6500-XX-XX type vent.

2.6. Dimensions

The following dimensions are for all the standard and continuous EPV-6500 vents.

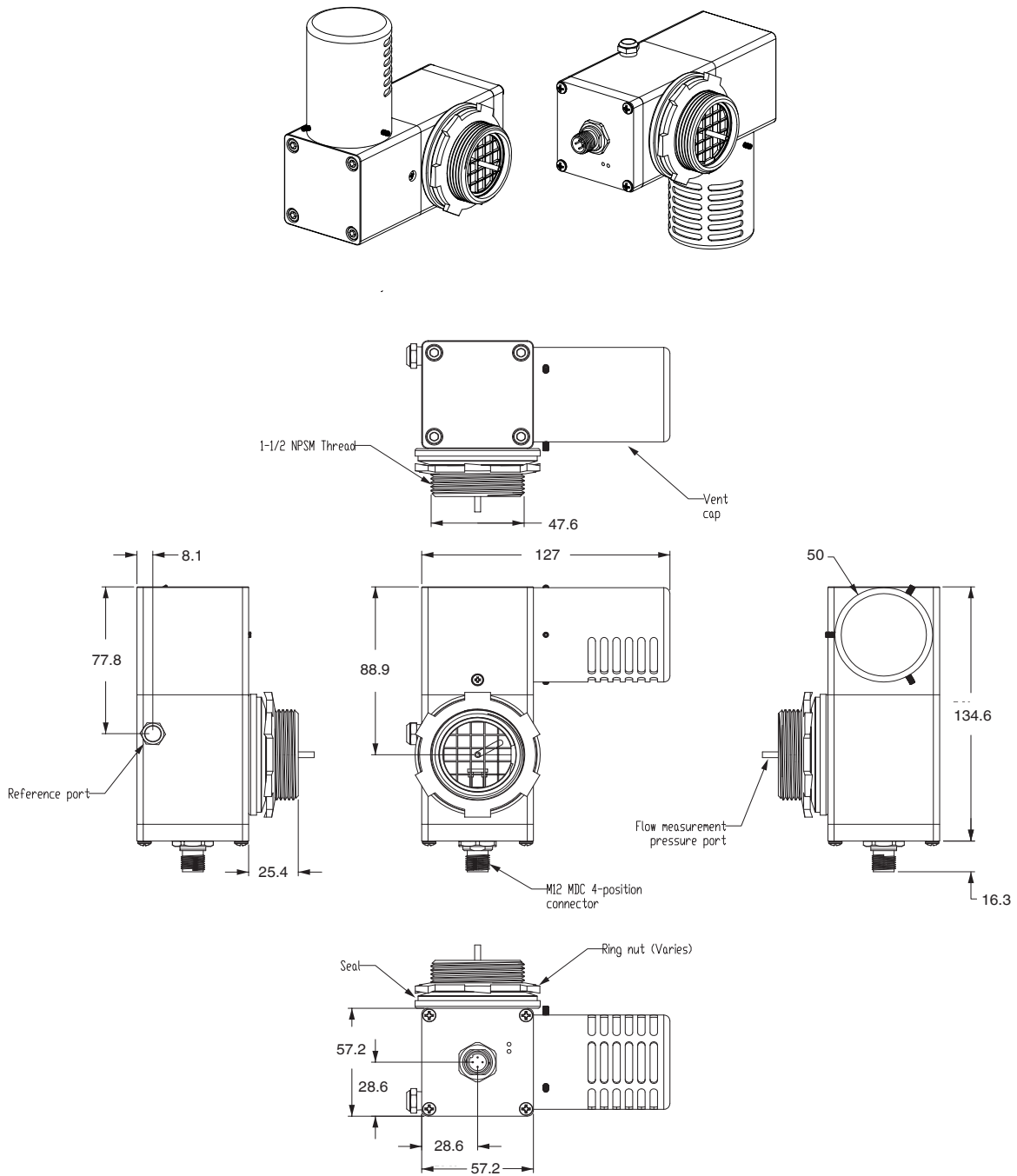

Dimension shown in mm (in).

2.6.1 Flow rate curves

Standard vent pressure/flow curves:

The enclosure pressure vs. flow rate curves correspond to the EPV-6500-__-01, 03, 05, vents. This corresponds to the enclosure pressure and is independent of the valve used, provided it can deliver the flow rate required.

These curves are a result of testing on a completely sealed enclosure, which may not be representative of the customer's enclosure, if not completely sealed. The flow in these curves are measured at the vent, which represents the exhaust of the system. More flow may be required to reach the enclosure pressure due to leakages from gaskets, seals, windows, etc.



Note

These graphs should only be used for representation of flow and pressure through each type of vent and not used for calculating purge time. They can be used for estimating purge time, but the actual purge time will be automatically calculated by the 6500 control vent. These graphs are used to determine which vent type will be best suited for the application.

EPV-6500-__-01: Normally used for large enclosures with shorter purge times

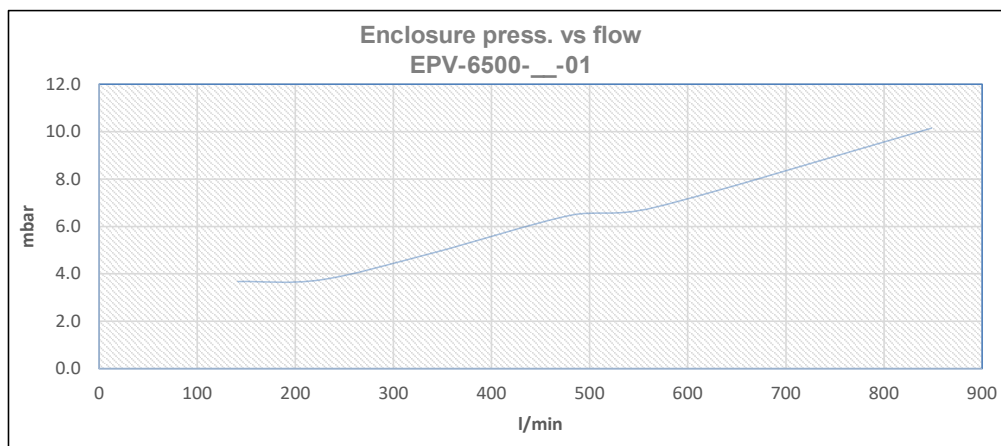

EPV-6500-__-03: Normally used for medium or large enclosures, where the leakage rate is critical and a short purging time is required

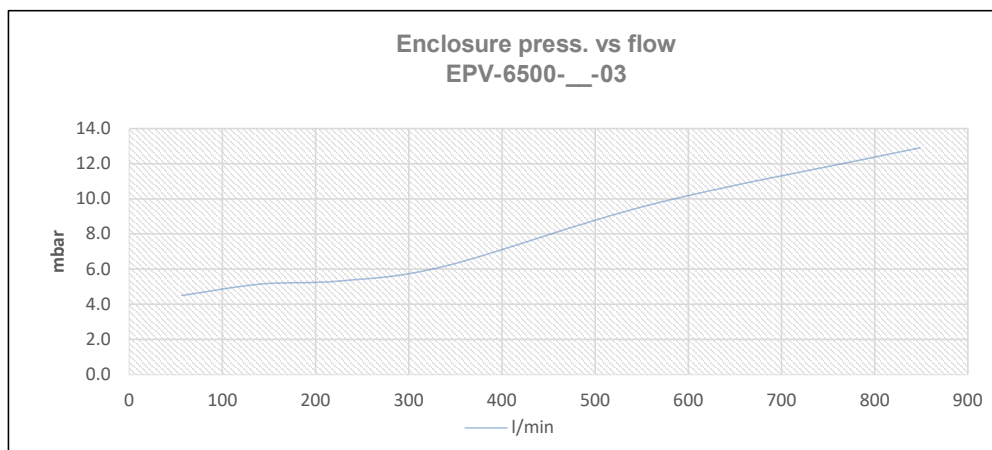

EPV-6500-__-05: Gives the best seal for pressurization, but highest back pressure for purging

**Enclosure pressure vs. flow rate
EPV-6500-__-05**

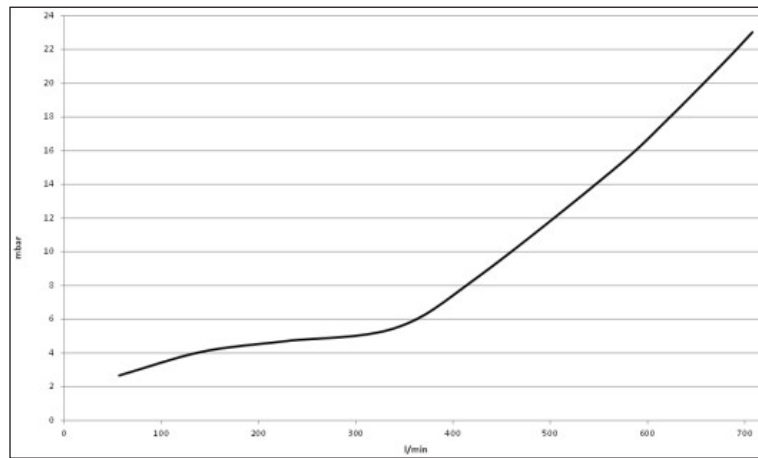

Continuous vent pressure/flow curves

The enclosure pressure vs. flow rate curves correspond to the EPV-6500-__-07, -08 vents. This corresponds to the enclosure pressure and is independent of the valve used, provided it can deliver the flow rate required.

These curves result from testing on a completely sealed enclosure and may not be representative of the customer's enclosure, if not completely sealed. The flow in these curves are measured at the vent, which represents the exhaust of the system. More flow may be required to reach the enclosure pressure due to leakages from gaskets, seals, windows, etc.

EPV-6500-__-07: The vent has an 8mm diameter opening and requires a continuous flow to maintain pressure/flow.

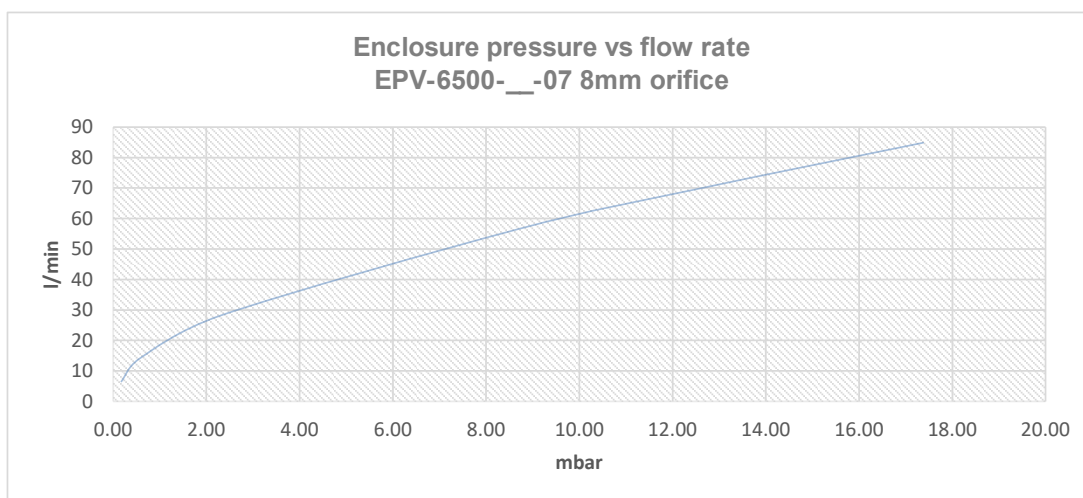

8 mm orifice

EPV-6500-__-08: The vent has a 16mm diameter opening and requires a continuous flow to maintain pressure/flow.

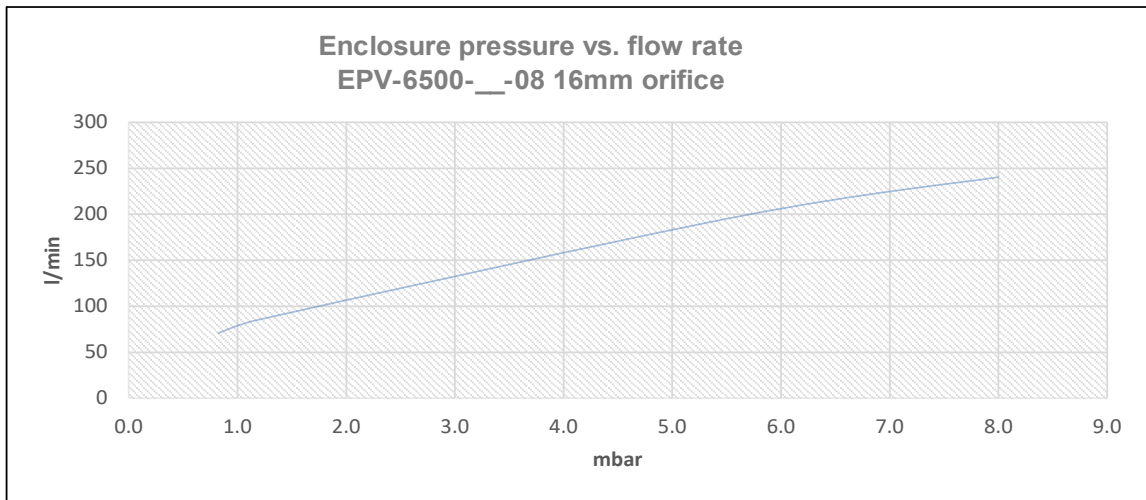

Mounting the EPV-6500 vent, inside and outside:

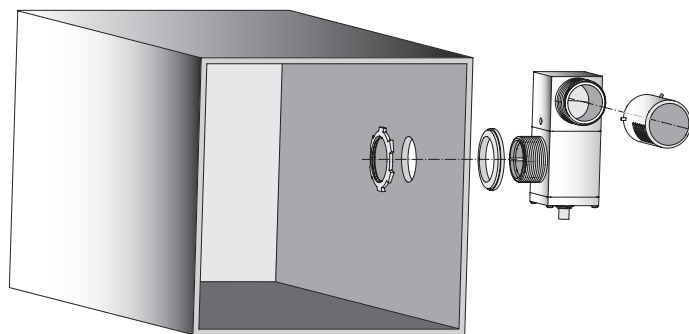

External vent

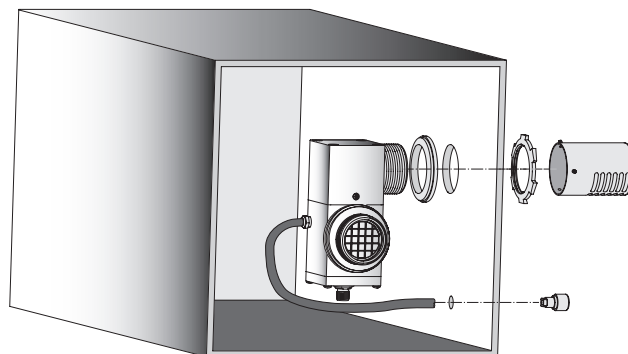

Internal vent

(Reference hardware included with EPV-6500-SS vent)

2.7. Manifold valves

The 6500 system requires a purge/pressurization supply source. This flow/pressure is usually supplied by an electrical valve or manual valves. Pepperl+Fuchs offers optional valves for operation with the 6500 system for both standard applications (digital valves) and dilution applications (proportional valves).

2.7.1 6500-MAN-DV

The 6500-MAN-DV-... is used for standard applications and consists of a digital (solenoid) valve and needle valve in one compact design. The valve comes with mounting hardware for inside or outside of the pressurized enclosure installation. The pneumatic ports on the unit are stainless steel 10m tube compression fittings.

This valve is used in standard applications where dilution is not required and meets the I.S. requirements. Datasheets for the 6500-MAN-DV valves are available at www.pepperl-fuchs.com.



2.7.2 Technical Data

Item	Value
General Specifications	
Series	6500
Temperature rating	-40 °C ... 50 °C
Electrical specificaiton: IS data	
U _i	28 V for IIC, 32 V for IIB
I _i	115 mA for IIC, 195 mA for IIB
P _i	1.6 W
L _i ≈	0
C _i ≈	0
Max pressure	120 psi
Max temperature of medium	-70 °C
CCC Certification information	
Certificate number	2021322307003982
Ex marking	Ex ia IIC T6 Gb, Ex ia IIB T4/T6 Gb

2.7.3 6500-MAN-PV

The 6500-MAN-PV is usually used for dilution applications, but it could be used for standard applications for better control of pressure and flow after purging (pressurization). The valve comes with mounting hardware. The pneumatic ports on the unit are stainless steel 10m tube compression fittings.

Datasheets for the 6500-MAN-DV valves are available at www.pepperl-fuchs.com.



WARNING!

For customer-supplied electrical valves, please consult the 6500 control unit entity parameters.

2.8. Cable glands (6500-CBLG...)

The 6500 control unit does not come with cable glands. These can be supplied by the customer or can be purchased from Pepperl+Fuchs as a kit. Pepperl+Fuchs offers cable gland kits in several different materials for both the power side and the I.S. side entries.



The 'P' power side of the 6500 control unit requires (2) M16 cable glands, usually for power to the 6500 unit and enclosure power (contact output), and (2) M12 cable glands for auxiliary contact output and RS-485 connection. The cable glands are available in stainless steel, nickel-plated brass, or plastic. All types are certified and matched to the 6500 certifications. Each cable gland also includes the approved blanking plug for the cable gland selected. Lock nut is also included.

Customer supplied cable glands are allowed by the certification of the 6500 and has to meet the area classification certification. The termination of the cable glands to the 6500 housing will require a locking washer because the housing is not threaded. The intrinsic safe side of the 6500 control unit requires (5) M12 cable glands for I.S. field devices to and from the 6500 control unit. The cable glands are available in stainless steel, nickel-plated brass, or plastic. All types are certified and matched to the 6500 certifications. Each cable gland also includes the approved blanking plug for the cable gland selected. Lock nut is also included.



WARNING!

Customer-supplied cable glands and blanking plugs must be certified for the area classification.



Note

Special consideration may be required if ambient temperatures are above 60 °C; entries into the control unit can exceed 70 °C. Consult EN/IEC 60079-14 and other local and national codes.

3. Installation and Operation

The 6500 control unit, EPV6500 vent, and manifold can be universally mounted to the customer's enclosure to produce a certifiable system, configurable to either a "pyb" or "pxb" system.

For "pyb" systems, all electrical equipment within the pressurized enclosure must be rated Zone 2 or 22, if applicable, and the enclosure contacts do not have to be de-energized when loss of pressure, but an alarm has to be activated. In the "pyb" mode, the AUX contacts will energize when the pressure drops below the minimum overpressure setpoint. Because the AUX is automatically mapped to this alarm, no output function can be assigned to the AUX contacts.



Note

The AUX contacts will energize on either function. For applications where the enclosure contacts have to be de-energized when loss of pressure in a "pyb" classification, choose the "pxb" mode.

3.1. Installation

3.1.1 For Gas Atmospheres

In order to make sure an enclosure does not have hazardous gas trapped inside, purging is required. This is done any time the enclosure is below the minimum overpressure in the hazardous area. For purging, a protective gas is introduced into the enclosure so that the pressure builds up and the flow is exhausted through the enclosure. The measurement of this flow is achieved through the vent, which feeds back to the control unit pressure and flow. The enclosure must be sufficiently purged to reduce hazardous gas to a safe level. The enclosure must then maintain a minimum pressure to prevent the hazardous atmosphere from re-entering the enclosure. After purging, the flow into the enclosure can be reduced to hold the pressure due to leakages. The vent will feed back the pressure to the control unit to alarm, de-energize the enclosure contacts, and control the pressure, if possible.

The protective gas used for purging, pressurization and continuous dilution shall be non-combustible and non-toxic. It shall also be substantially free from moisture, oil, dust, fibres, chemicals, combustibles and other contaminating material that may be dangerous or affect the satisfactory operation and integrity of the equipment. It will usually be air, although an inert gas may be used, particularly when there is an internal source of release of flammable material. The protective gas shall not contain more oxygen by volume than that normally present in air.

Where air is used as the protective gas, the source shall be located in a non-hazardous area and usually in such a position as to reduce the risk of contamination. Consideration shall be given to the effect of nearby structures on air movement and of changes in the prevailing wind direction and velocity. Care should be taken to keep the temperature of the protective gas below 40 °C at the inlet of the enclosure. In special

circumstances, a higher temperature may be permitted or a lower temperature may be required, in which case the temperature shall be marked on the pressurized enclosure.

Where inert gas is used, particularly in large enclosures, measures shall be taken to prevent the danger of suffocation. Pressurized enclosures using inert gas as the protective gas should be marked to indicate the hazards, for example:

“WARNING – THIS ENCLOSURE CONTAINS INERT GAS AND THERE MAY BE A DANGER OF SUFFOCATION. THIS ENCLOSURE ALSO CONTAINS A FLAMMABLE SUBSTANCE THAT MAY BE WITHIN THE FLAMMABLE LIMITS WHEN EXPOSED TO AIR.”

3.1.2 For Dust Atmospheres

Purging is not required for dust atmospheres. If the enclosure is located in a dust atmosphere and is below the minimum overpressure setpoint, the enclosure must be checked and cleaned of all combustible dust, sealed (door and any other access points closed), and then pressurized to prevent combustible dust from getting inside. As long as the minimum overpressure is above the setpoint, the power to the enclosure can be energized. The vent will feed back the pressure to the control unit to alarm, de-energize the enclosure contacts, and control the pressure, if possible.

3.1.3 For Dust and Gas Atmospheres



DANGER!

EN and IEC 60079-2 standards do not state these requirements. Special consideration is needed as part of an evaluation by a proper certification body or other authority having jurisdiction.

3.1.4 Dilution Applications

Dilution applications usually deal with gas analyzers that are located inside the pressurized enclosure and are bringing in a stream of the hazardous gas for analysis. Any equipment, including piping, that contains this hazardous gas within the pressurized enclosure is called the containment system. The containment system will have the potential to leak under normal and abnormal conditions, with a known or unknown leakage rate of this hazardous gas. If the leakage rate is known, the 6500 system may be used to dilute the area or specific area within the enclosure to make other equipment safe to operate in the dilution area.



WARNING!

For specific information on dilution requirements and testing, please refer to IEC 60079-2.

Dilution applications can only be considered with the normal and abnormal leakage rates known. Please refer to the 60079-2 to determine if dilution can be considered for your applications. In most cases, explosive liquids are not allowed and unlimited releases may require the protective gas supply to be inert gas only.

The following example explains the dilution area and how potential leak points in the containment system can affect the positioning of equipment. It is suggested that any equipment that needs to operate in the enclosure that is an ignition capable apparatus (ICA) should be isolated from the leaking containment system. The protective gas supply is introduced into the enclosure at the location of the ICA and dilutes the area so that the equipment can operate when the system is operating.



WARNING!

For customer-supplied electrical valves, please consult the 6500 control unit entity parameters.

Any equipment operating within the enclosure outside the dilution area would have to be protected for the hazardous area, i.e., Ex e, m, i, etc.

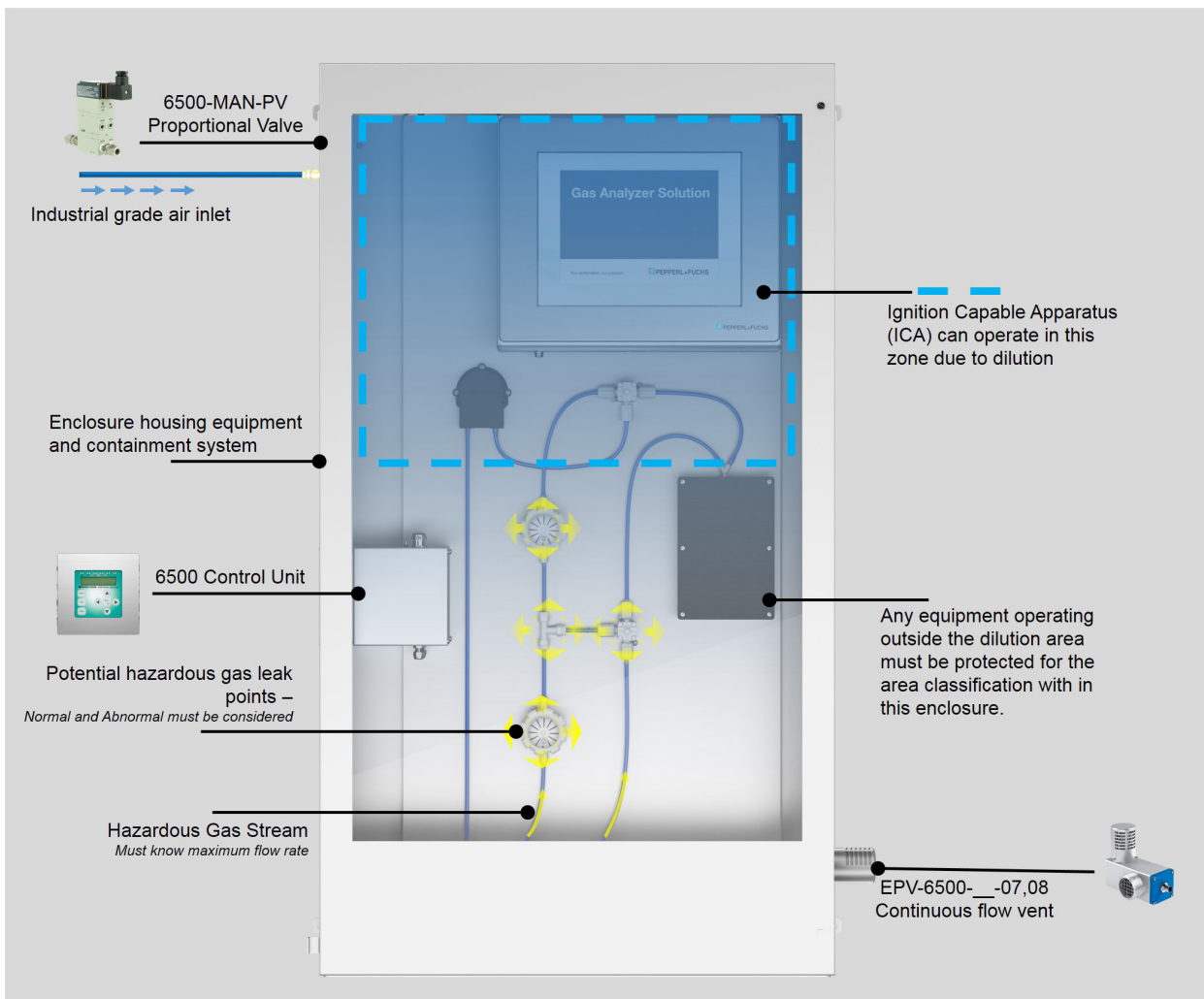

For dilution to properly be applied, the 6500 system would have to use the continuous vent (EPV-6500-__-07 or 08) and a proportional valve like the 6500-MAN-PV. The continuous vent accurately measures the pressure and flow across an open orifice plate inside the vent to give flow vs. pressure curves for setting up the dilution requirement. For the setup, the 6500 will purge the enclosure at a user-set flow rate and after purging, the flow will settle at a user-set dilution flow. From the flow curves for each continuous vent. The 6500 menu also has a MIN FLOW SP (minimum flow setpoint) that can be used to alarm the user if the dilution flow is too low. For shutting down the system, from the vent flow/pressure curves, the enclosure pressure for the shutdown flow in the curves can be used for the minimum overpressure value for de-energizing enclosure contacts.

Below is an example of a dilution application. In this example, the user has set up the enclosure for a dilution area as shown above and has calculated the required flow for dilution by knowing the normal and abnormal releases.

Equipment used:

- 6500-01-... control unit
- EPV-6500-AA-07, continuous vent with 8 mm diameter orifice
- 6500-MAN-PV-01 proportional valve
- 6500-CBLG-... cable gland set for 6500 control unit (optional)

Required flow for dilution = 45 l/min

From the 6500 menu for purge settings, the following dilution parameters are selected. All of these parameters and setpoints are user selectable.

MENU	PARAMETER	DESCRIPTION
VENT FLOW CONTROL	Dilution	User is going to set up system for dilution
VALVE CONTROL	Proportional	Proportional valve output on the 6500 control unit will be used
DILUTION SETTINGS	Purge flow	The flow rate for purging the enclosure by the proportional valve
	Dilution Flow SP	The flow rate for dilutions. This valve should be higher than the minimum required flow because of variations in line pressures and reaction time of the PV.
	Min Flow SP	If the flow rate drops below this setpoint, alarm is generated.
PRESSURES	Min Overpressure	The pressure associated with the minimum flow for dilution to shut off the enclosure contacts.
	Max Overpressure	Maximum enclosure pressure will adjust PV below this value.

The flow curve for the EPV-6500-__-07 shows the enclosure pressures for the various flows. From these curves, if it is required to shut power off to the enclosure if flow drops below the minimum flow rate for dilution, then this pressure for the flow is selected for the minimum overpressure value.

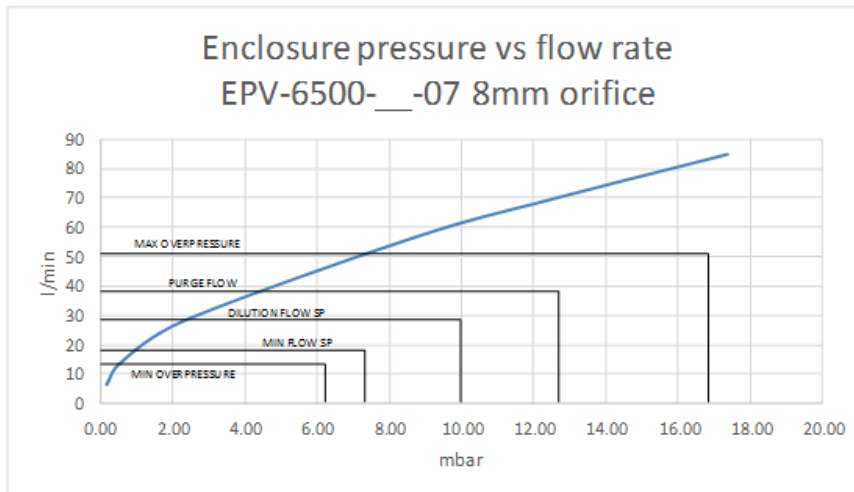

PARAMETER	FLOW (L/MIN)	PRESSURE (MBAR)
MAX OVERPRESSURE	82	16.6 (user-selected)
PURGE FLOW	70 (user-selected)	12.5
DILUTION FLOW SP	60 (user-selected)	9.8
MIN FLOW SP	50 (user-selected)	7.1
MIN OVERPRESSURE	45	6.0 (user-selected)



Note

There will always be a delay in the reaction time of the proportional valve to a change in the line pressure to achieve setpoint. The amount of time will depend on size of the enclosure, the amount of change in the line pressure, the speed of the change, and other factors. These factors also affect the over and under shoot of the proportional valve. Reaction times are dependent on the complete system and final adjustments may have to be made while the system is commissioned.

3.2. Before Setup

When the 6500-01-* control unit is received, the humidity indicator card should be checked.

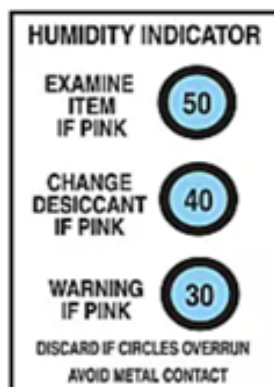

S-1547

If the indicator card is reading 40 or 50, follow the instructions on the desiccant pack to recharge it. Once recharged, or if the indicator card is reading 30 or below upon receipt, proceed with commissioning the unit.

The desiccant pack should be removed during commissioning and stored in a sealed bag.

During commissioning, if the unit is exposed to very humid environments (85% relative humidity), the unit should not be left open (unsealed) for longer than 24 hours or saturation could occur. If the relative humidity is 40% or lower, the unit can remain unsealed for up to 1 week. It is recommended that whenever the unit is not being directly worked on, it should remain sealed by attaching the lid and sealing the cable gland entries with the indicator card and desiccant pack inside the control unit.

Once final commissioning is complete, the desiccant pack must be placed back inside the control unit between the terminal blocks (in the area shown below) and the unit should then be sealed by placing the lid back on the unit. The indicator card can be discarded.

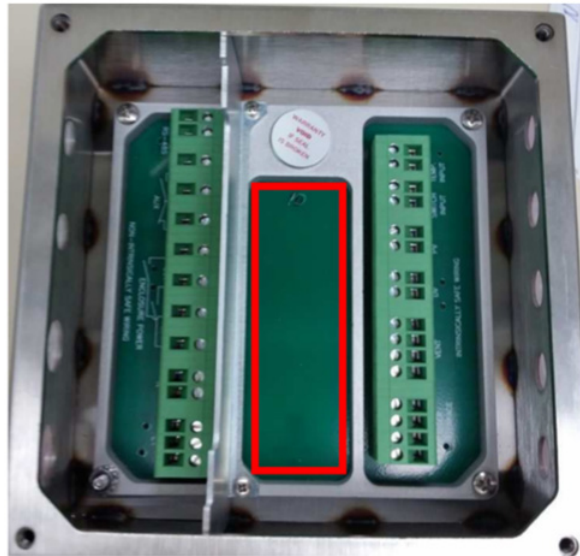

Once the unit is in service, the desiccant pack should be inspected every three years. If the blue dot on the desiccant pack turns pink, it should be removed and the recharging instructions on the desiccant pack should be followed. Once the desiccant pack is recharged, it can be placed back into the control unit and the unit can be returned to service.

3.2.1 Setup procedures for standard applications

Instructions

1. Ensure that electrical, mechanical, and pneumatic connections and requirements are met before operation of the system. Refer to this manual and applicable standards/ codes, including the current edition of the EN/IEC 60079-14, for explanation of requirements. Electrical supply to the purge system shall be supplied through a switch or circuit breaker to provide a method of disconnect from the supply source.
2. Do not connect a protective gas supply to the system or turn it off for setup.
3. Apply power to the 6500 system.
4. Define the 6500 system parameters in the menu structure for the application. Refer to “Programming Menu” section for instructions.
5. Set the user interface on the 6500 control unit to pressure for indication of enclosure pressure.
6. Turn on the protective gas supply. Set the regulator to its lowest setting and then gradually increase pressure. When starting any system, it is best to start slowly to make sure the EPV-6500 vent is connected properly for pressure relief by checking to make sure the purge gas is exhausting from the enclosure. Do not exceed pressure ratings of the system.
7. If the unit is in the “SA” mode (semi-automatic), then purging will not automatically begin. Be aware that if the unit is in the “FA” mode, as soon as the enclosure pressure is greater than the min overpressure, purging will start. The unit default from factory is “SA” mode.

The system is ready to operate.

For dilution applications, the procedures will be the same but the flow rate will be the setpoint desired for operation of the system. The user interface display can be scrolled to show flow rate. Note that the desired flow rate required must be greater than the min overpressure setpoint to operate.

3.3. Operation for standard applications

Gas hazardous location

- Follow setup procedures in this section.
- Seal enclosure.
- Pressure is set to a value above the minimum overpressure setpoint in the user interface menu for purge settings. This pressure can be set below 0.82 mbar (0.33 in wc).
- Depending on how the purging is selected (SA or FA mode), purging the enclosure is required.
- After a successful purging, with the pressure in the enclosure above the minimum overpressure setpoint, the enclosure is considered safe and power to the enclosure can be energized.
- If the enclosure pressure drops below the minimum overpressure setpoint, then action is required. For “pxb”, enclosure contacts have to be de-energized. For “pyb”, enclosure contacts can remain on but an alarm must be initiated (this is done through the AUX contents on the 6500 control unit).

Combustible dust locations

- The pressurized enclosure must be cleaned out of all combustible dust and sealed. Purging cannot be done to clean out the pressurized enclosure.
- Set the enclosure pressure above the minimum overpressure setpoint. Minimum pressure is 0.82 mbar (0.33 in wc).
- With the enclosure pressure above the minimum overpressure setpoint, it is considered safe and the power to the enclosure can be energized.
- If the enclosure pressure drops below the minimum overpressure setpoint, then action is required. For “pyb”, enclosure contacts can remain on, but an alarm must be initiated (this is done through the AUX contacts on the 6500 control unit).



DANGER!

Gas and combustible dust locations

EN and IEC 60079-2 standards do not state these requirements. Special consideration is needed as part of an evaluation by a proper certification body or other authority having jurisdiction.

Dilution applications

Startup for dilution applications will be the same as the standard, but the conditions for operating the equipment may require action to be taken if the flow rate used for dilution falls below its minimum setpoint. An alarm is activated for the minimum flow point, but for de-energizing the enclosure contacts, the minimum overpressure is used. This can be referenced to a flow from the Flow vs. Enclosure Pressure Cures of Setpoint Value.

3.4. Sequence of Events

3.4.1 Energizing enclosure power

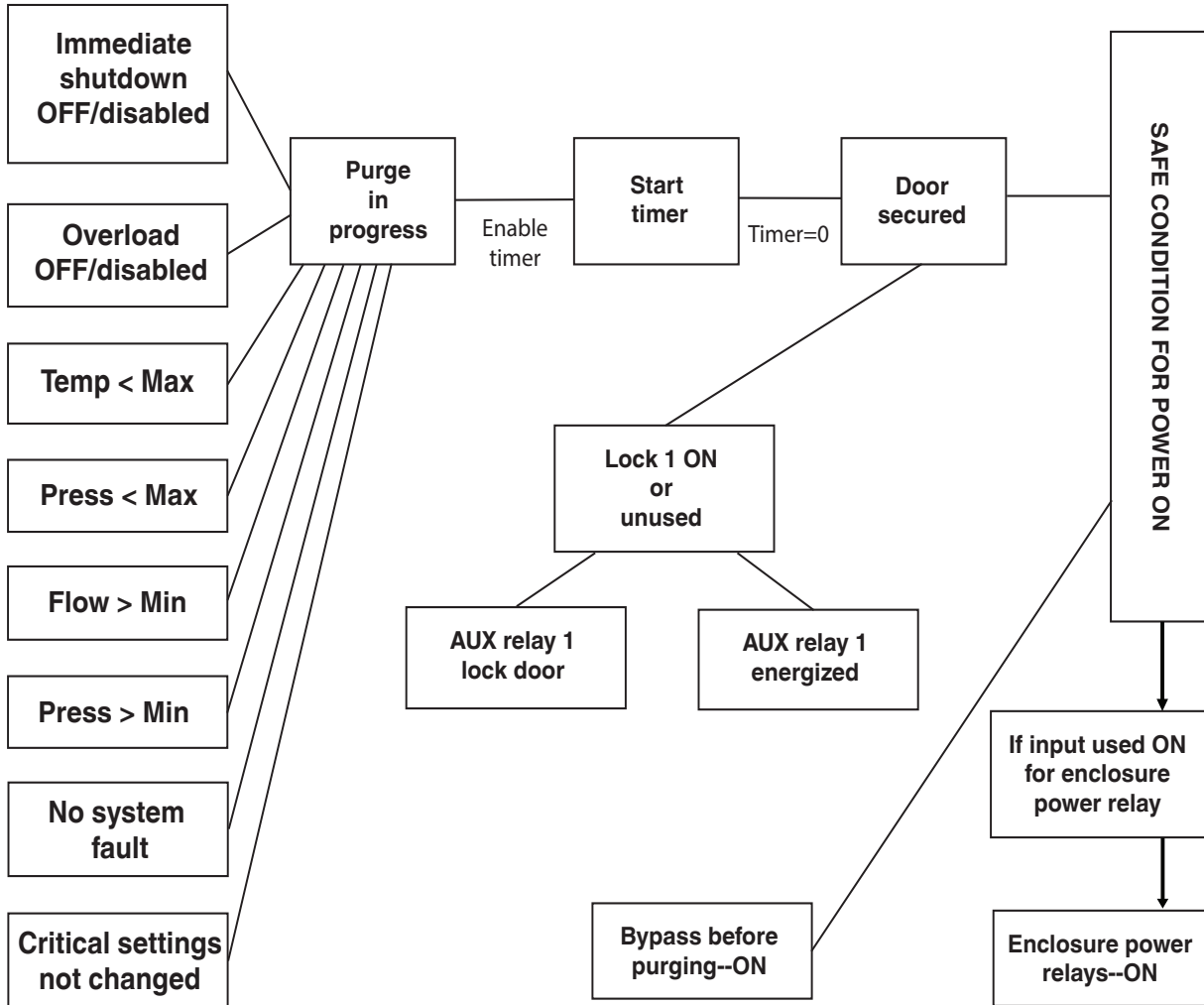

Critical purge settings: Volume change, number of exchanges, environment, and minimum overpressure

3.4.2 De-energizing enclosure power

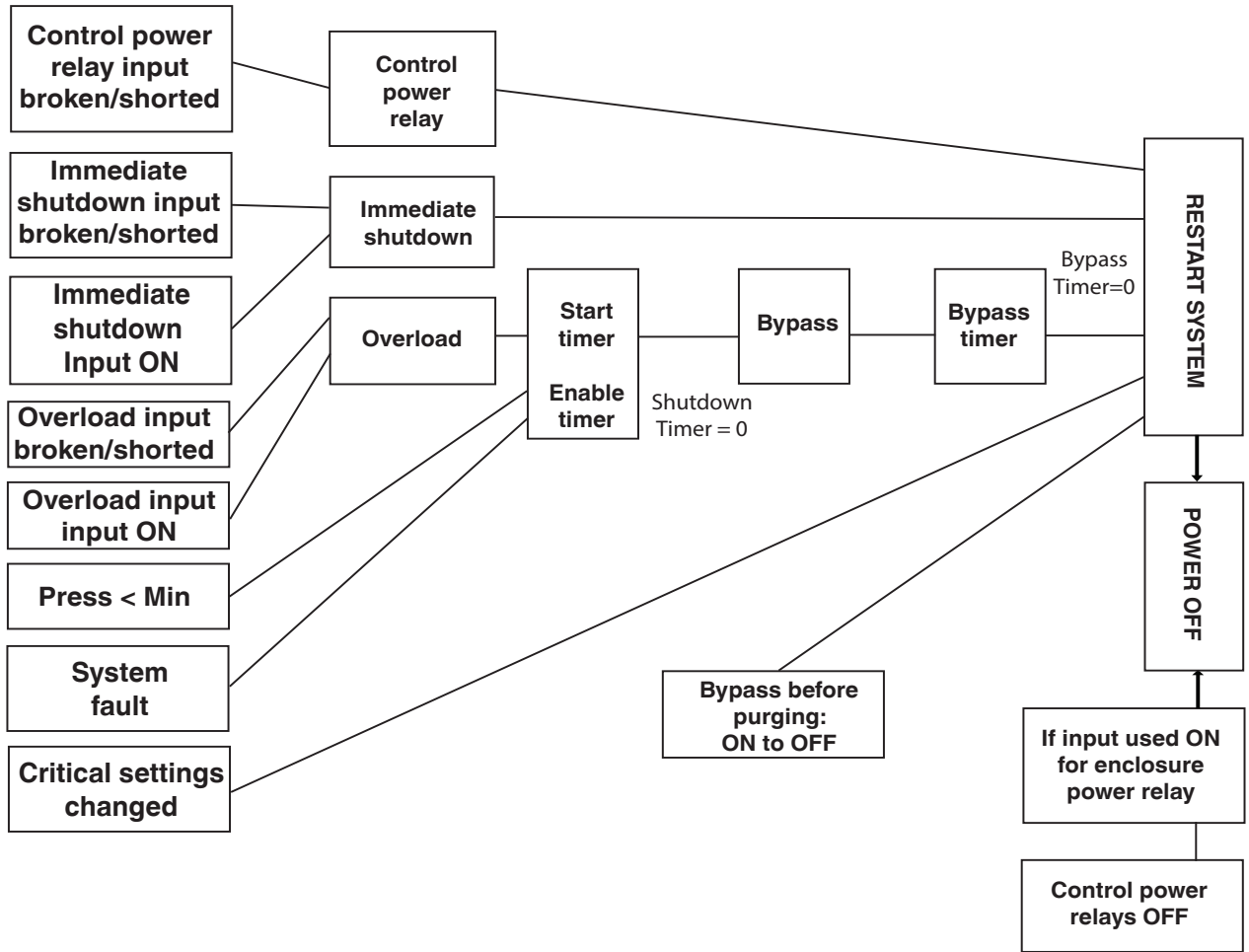

Critical purge settings: Volume change, number of exchanges, and environment

4. Programming

4.1. User Interface

The user interface uses capacitive touch technology to activate the buttons.

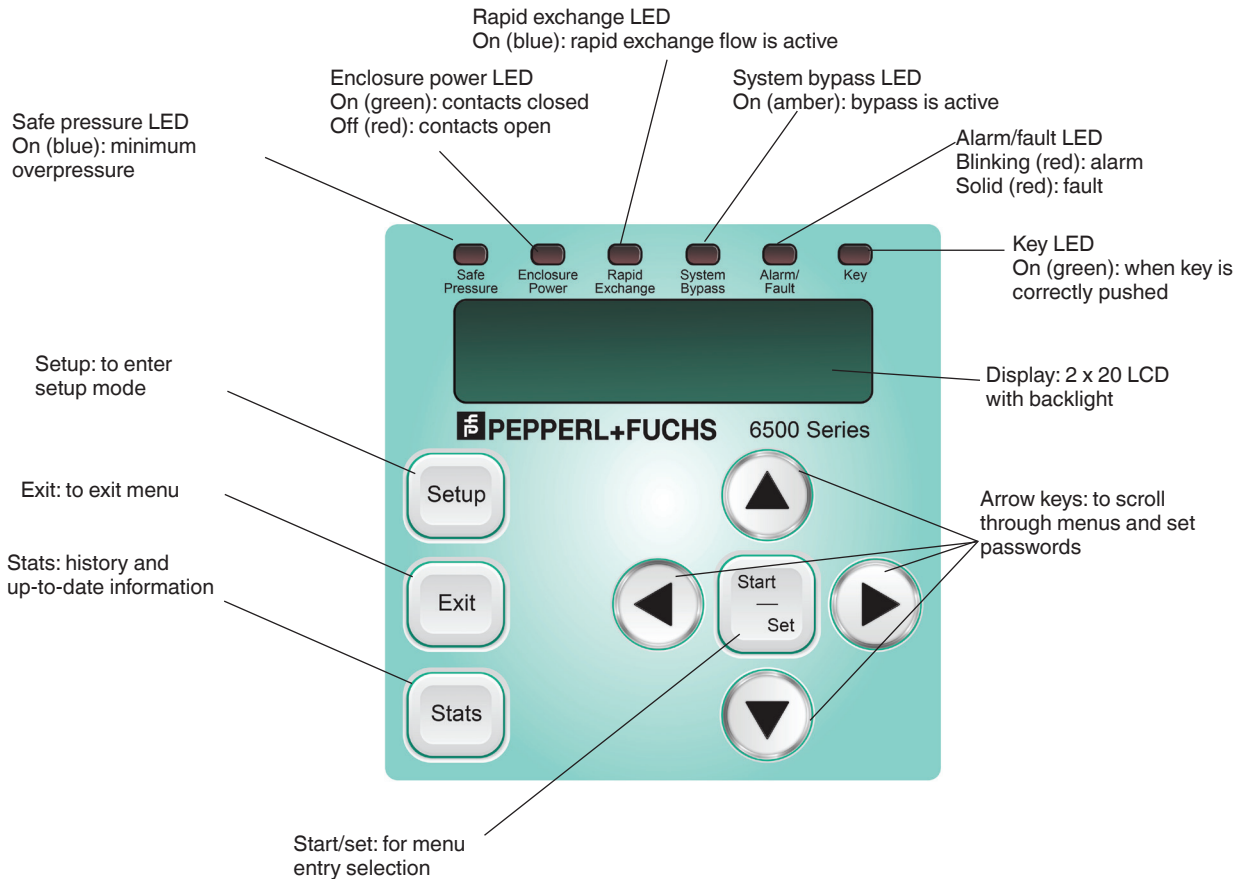

Note

To turn on the back light on the 6500 display, push the Right and Left arrow key at the same time. To turn it off, repeat.



Note

To change the contrast in the 6500 display, push the Up and Down arrow keys at the same time, then adjust the contrast to the desired value.



Note

During setup or STATS, if there are more than 60 seconds between keystrokes, the unit will revert to the operation screen.

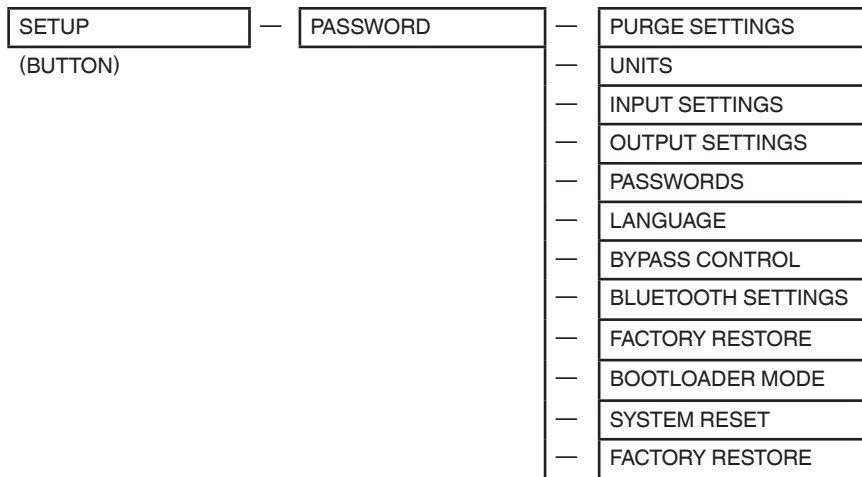
PROGRAMMING MENU:**PURGE SETTINGS:**

PURGE TYPE	Px or Py
ENCLOSURE VOLUME	USER DEFINED
NUMBER OF EXCHANGES	5 TO 19
ENVIRONMENT	GAS, DUST, BOTH
PRESSURES	MAX, LOW, MINIMUM
TIMERS	SHUTDOWN, UNLOCK
OPERATION MODE	SA, FA
VENT FLOW CONTROL	STANDARD, DILUTION
VALVE CONTROL	DIGITAL, PROPORTIONAL
DILUTION SETTINGS	PURGE FLOW, DILUTION FLOW SP, MIN FLOW SP

PURGE TYPE:

User-defined selections allow the system to operate as an 'Ex px' (nonhazardous to Zone 1/21) or 'Ex py' (Zone 2/22 to Zone 1/21).

Selection: 'px' or 'py'

Default: 'px'

ENCLOSURE VOLUME:

User-defined. For free volume of enclosure to be pressurized.

Selection: 0 to 12.75 cu.m (0 to 450 cu.ft.)

Default: 0 m²

NUMBER OF EXCHANGES:

User-defined. Number of exchanges is the amount of enclosure volume changes for purging.

Selection: 5 to 19. Five is the minimum for the applicable standards.

Default: 5

ENVIRONMENT:

User-defined. The hazardous area classification in which the pressurized enclosure will be located. GAS requires purging. DUST requires cleaning out the enclosure before powering. Both require cleaning out the enclosure then purging before enclosure contacts are on.

Selection: GAS, DUST, BOTH

Default: GAS

**DANGER!****Gas and combustible dust locations**

EN and IEC 60079-2 standards do not state these requirements. Special consideration is needed as part of an evaluation by a proper certification body or other authority having jurisdiction for an environment that has both gas and dust.

PRESSURES:

User-defined.

MAX OVERPRESSURE: The maximum enclosure pressure allowed. If max pressure is reached, the alarm status is on and the DV (digital valve) will shut off and the PV (proportional valve) will reduce flow until pressure is below the max pressure setpoint. Range is from 0.82 mbar (0.33 in wc) to 25 mbar (10 in wc).

LOW PRESSURE: Usually set above the Min Overpressure but below the “Pressure As An Input” function ON setpoint and acts as an alarm. Range is from 0.82 mbar (0.33 in wc) to 25 mbar (10 in wc).

MIN OVERPRESSURE: The minimum pressure the system can operate properly. Range is from 0.82 mbar (0.33 in wc) to 25 mbar (10 in wc).

Default: MAX = 10 mbar (4” wc); LOW = 0.82 mbar (0.33 in wc); MIN = 0.82 mbar (0.33 in wc)

TIMERS:

User-defined.

SHUTDOWN TIMER: For Ex px applications, enclosure pressure < MIN OVERPRESSURE will de-energize enclosure contacts. Shutdown timer allows the user to select the amount of time to delay de-energizing the enclosure. This is useful when there are short pressure drops in the system. Range is from 0 to 300 seconds

UNLOCK TIMER: Unlock timer is used to control the AUX contact output.

Range is from 0 to 300 minutes

Default: Shutdown Timer = 0 seconds; Unlock Timer = 0 min

OPERATION MODE:

User-defined.

SA (Semi-automatic): To start the purge cycle, the MIN OVERPRESSURE must be greater than the setpoint and the Start/Set button has to be pressed.

FA (Fully-automatic): Once the min overpressure is achieved, purging will begin.

Default: SA

VENT FLOW CONTROL:

User-defined. Determines the type of vent that will be used.

STANDARD: EPV-6500-__-01, 03, 05 vents are used. These are used when the pressurized enclosure does not have a containment system.

DILUTION: EPV-6500-__-07, 08 vents are used. This is used in conjunction with a proportional valve and is used for dilution of containment systems within the pressurized enclosure.

Default: STANDARD

VALVE CONTROL:

User-defined. Determines the type of valve that will be used.

DIGITAL: This controls the 'DV' output on the 6500 control unit and will activate a digital valve (solenoid valve) when purging, if the pressure as an input function is set up, if the temperature as an input is set up, or if an external input is set to trigger it. Usually used with standard applications. Can be used with the 6500-MAN-DV valve.

PROPORTIONAL: This controls the 'PV' output on the 6500 control unit and will control flow/pressure within the enclosure at a setpoint for purging and dilution. Usually used with the dilution valve, but could be used with the standard valve for more precise control of protective gas supply.

Default: DIGITAL

DILUTION SETTINGS:

User-defined. This is only accessible when the vent flow is dilution.

PURGE FLOW: The setpoint for user required flow rate for purging the pressurized enclosure

DILUTION FLOW SP: The setpoint for user required flow rate for dilution of the containment system within the enclosure.

MIN FLOW SP: If flow goes below this setpoint, the alarm is activated but enclosure contacts still remain on. For de-energizing the enclosure contacts, set MIN OVERPRESSURE to the flow rate of the vent selected for de-energizing.

Default values are as follows:

- PURGE FLOW = 0.0 l/min (0.0 scfm)
- DILUTION FLOW SP = 0.0 l/min (0.0 scfm)
- MIN FLOW SP = 0.0 l/min (0.0 scfm)

UNITS:

UNITS	—	IMPERIAL
	—	METRIC

PARAMETER	METRIC UNITS	IMPERIAL UNITS
PRESSURE	mbar	Inches of water (in wc)
FLOW	l/min (liters/min)	scfm (std cubic feet/min)
TEMPERATURE	° C (Celcius)	° F (Fahrenheit)
ENCLOSURE VOLUME	m ³ (cubic meters)	ft ³ (cubic feet)
TIME	seconds	seconds

INPUT SETTINGS:

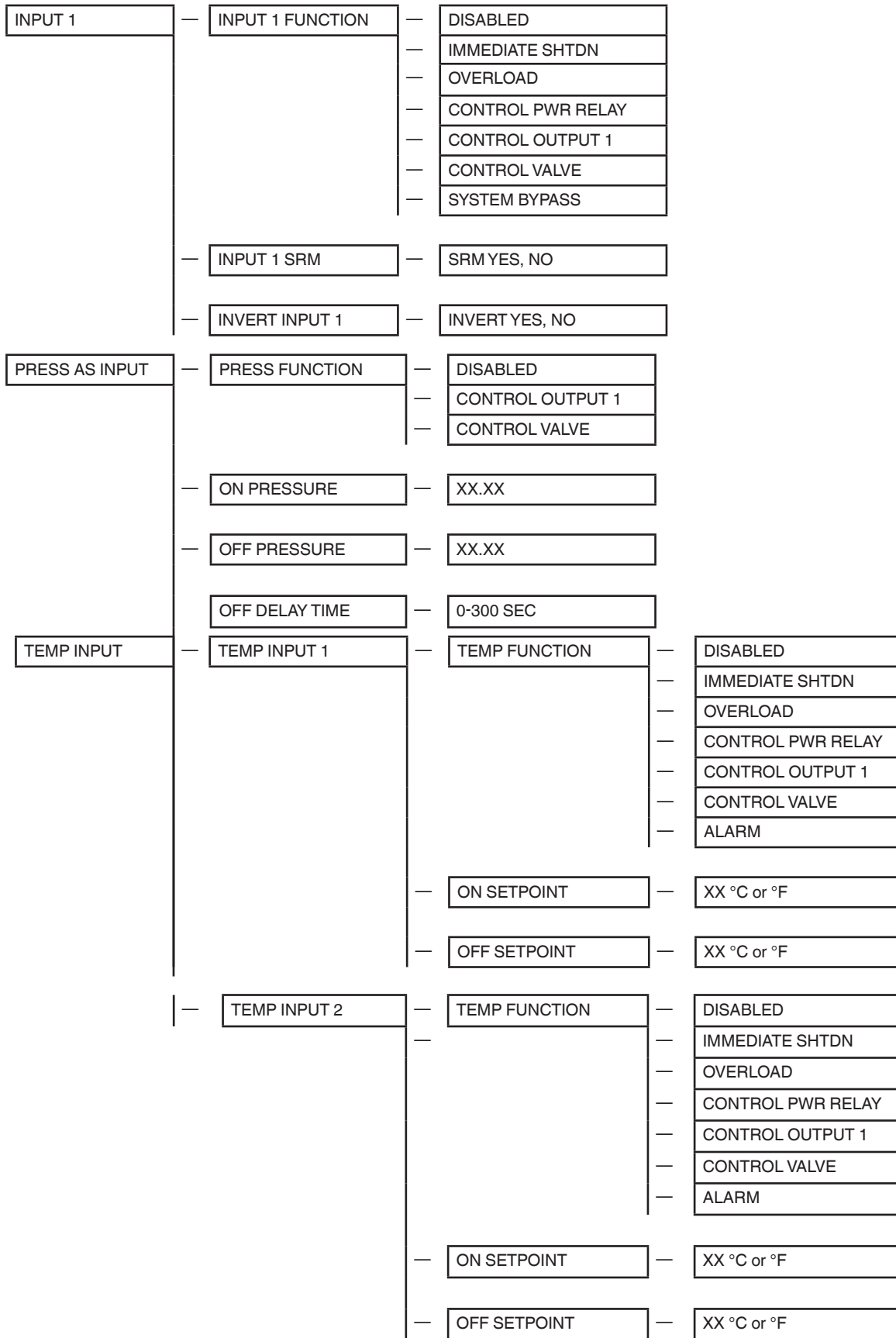

INPUT 1 FUNCTION:

The input terminal on the 6500 control unit can be used to activate several functions as listed in the table below.

FUNCTION	ACTION
DISABLED	Nothing happens when input is active
IMMEDIATE SHUTDOWN	When active, enclosure contacts immediately de-energize regardless of shutdown time. This acts like a system reset.
OVERLOAD	When active, enclosure contacts de-energize after shutdown time has timed out.
CONTROL POWER RELAY	When active, the enclosure contacts energize (but only if in safe condition after purging and enclosure is pressurized).
CONTROL OUTPUT 1	If VALVE CONTROL is set to PROPORTIONAL, CONTROL VALVE input setting will set the output to 100% when active.
CONTROL VALVE	When active, either the DV or PV valve output is active. For the PV, the value will go to 100%.
SYSTEM BYPASS	When active, the system bypass is active. This will only work for "Bypass after purging" and not before purging. Before purging is only active through the user interface.

Default: DISABLED

INPUT SRM:

When using switch inputs, a 6000-SRM (resistance network) can be added at the switch to indicate when the wire going to the switch is short or open. Must be used with the 6000 SRM.

Settings: YES or NO

Default: No

INVERT INPUT:

When selection is 'NO', the input is active when the switch is closed. When selection is 'YES', the input is active when the switch is open.

Selection: YES or NO

Default: NO

PRESSURE AS INPUT (PRESSURE FUNCTION):

If the digital valve is selected, then the function can alarm/control the enclosure pressure between the ON and OFF PRESSURE in this section. If the proportional valve is used, then the ON PRESSURE is used.

FUNCTION	ACTION
DISABLED	Nothing happens when pressure is below ON PRESSURE.
CONTROL OUTPUT 1	The control output is active when below ON PRESSURE and de-activated when above OFF PRESSURE.
CONTROL VALVE	The DV output is active when below ON PRESSURE and de-activated when above OFF PRESSURE.

OFF DELAY TIME:

If the digital valve is selected, this function will keep the digital valve on for the user-defined time after the off pressure is detected.

Settings: 0 to 300 seconds
 Default: 0 seconds

TEMP AS INPUT:

Used with the 2-wire RTD PT100 sensor, this will take action to control/monitor the temperature between max and min values. This can be used for cooling where the ON temperature is higher than the OFF temperature or heating where the ON temperature is lower than the OFF temperature. The actions of these functions are in the table.

FUNCTION	ACTION
DISABLED	Nothing happens when pressure is below ON PRESSURE.
IMMEDIATE SHUTDOWN	When active, enclosure contacts immediately de-energize, regardless of shutdown time.
OVERLOAD	When active, enclosure contacts de-energize after shutdown time has timed out.
CONTROL POWER RELAY	When active, the enclosure contacts energize (but only if in safe condition after purging and enclosure is pressurized).
CONTROL OUTPUT	When active, AUX contacts energize.
CONTROL VALVE	When active, either the DV or PV valve output is active for the PV, the value will go to 100%.
ALARM	When active, the LED is on and if the control output is directed to any alarm, the AUX contacts will energize.

ON SETPOINT:

The temperature when the action is activated.
 Default: 30 °C.

OFF SETPOINT:

The temperature when the action is de-activated.
 Default: 20 °C.

OUTPUT SETTINGS:

OUTPUT 1 FUNCTION	—	DISABLED
	—	IMMED SHUTDN ALARM
	—	OVERLOAD ALARM
	—	MAX PRESSURE ALARM
	—	LOW PRESSURE ALARM
	—	LOST PRESSURE ALARM
	—	ANNOUNCE PURGE
	—	ANY ALARM
	—	ENCLOSURE DOOR LOCK
	—	SYSTEM BYPASS ALARM
INVERT OUTPUT 1?	—	NO, YES

DOCT-B3V4B • 02/2025

OUTPUT FUNCTION:

The output settings affect the AUX (auxiliary contacts) on the 6500 control unit. The table below shows the different functions that can be directed to this output.

FUNCTION	ACTION
DISABLED	Nothing happens.
IMMEDIATE SHUTDOWN	AUX contacts energize when there is an immediate shutdown active
OVERLOAD	AUX contacts energize when there is an overload condition.
MAX PRESSURE ALARM	AUX contacts energize if the enclosure pressure exceeds the max pressure setpoint.
LOW PRESSURE ALARM	AUX contacts energize when the enclosure pressure drops below low pressure setpoint.
LOST PRESSURE ALARM	AUX contacts energize when the enclosure pressure drops below MIN OVERPRESSURE setpoint.
ANNOUNCE PURGE	AUX contacts energize when the system is purging.
ANY ALARM	AUX contacts energize when any alarm is active. The STATS menu will indicate the alarm.
ENCLOSURE DOOR LOCK	CONTROL OUTPUT 1 contacts energize and will de-energize after the UNLOCK DOOR TIMER has counted down.
SYSTEM BYPASS ALARM	AUX contacts energize when the bypass is active.
TEMP INPUT 1 ALARM	AUX contacts energize when temperature input 1 alarm is active.
TEMP INPUT 2 ALARM	AUX contacts energize when temperature input 2 alarm is active.

INVERT OUTPUT:

When selection is NO, the output is active when the function is active. When selection is YES, the output is active when the function is not active.

Selection: YES or NO

Default: NO

PASSWORDS:

During the first power up of the 6500 control unit, the setup and bypass passwords are entered in by the user. These passwords can be changed at any time. The passwords are key strokes from the up, down, right, and left keys on the user-interface. The identical consecutive key strokes are not allowed. The setup and bypass password can be the same but it is recommended to keep them different.

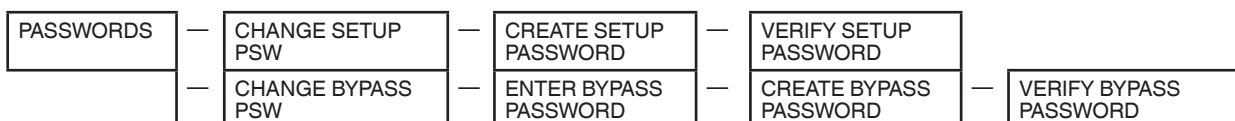

LANGUAGE:

During the first power-up of the 6500 control unit, the language is selected and can be changed at any time.

LANGUAGE	—	ENGLISH	—	SETTING CORRECT Y/N
	—	DEUTSCH	—	SETTING CORRECT Y/N
	—	ESPAÑOL	—	SETTING CORRECT Y/N
	—	FRANCAIS	—	SETTING CORRECT Y/N

BYPASS CONTROL:

To access the bypass, the bypass password has to be entered.

BYPASS CONTROL	—	PASSWORD	—	BYPASS ENABLE	—	NO, YES * FIXED/YES
	—		—	BYPASS ON	—	OFF, ON
	—		—	BYPASS BEFORE PURGE	—	OFF, ON

The bypass can be implemented one of two ways: through the user-interface bypass menu or through a switch input on the 6500 control unit. In either case, the BYPASS ENABLE must be 'ON' to implement the bypass function. Once the ENABLE is ON, then a switch input (mapped to the input function) or by going into the menu and selecting bypass on will activate the bypass.

FUNCTION	ACTION
BYPASS ENABLE	To allow the bypass to function, it must be enabled. NO disables the bypass and cannot enable even if a switch input is on for bypass. YES allows the function to operate but if unit powers down and powers back up, this enable will go back to NO. FIXED/YES allows the function to operate and if the unit powers down and powers back up, the enable will still be YES.
AFTER PURGE ON	Once the bypass is enabled, the bypass can only be activated after the enclosure has been purged or cleaned and the pressure is above the MIN OVERPRESSURE
BEFORE PURGE ON	Once the bypass is enabled, the bypass can be active before and after the enclosure has been purged or cleaned. This allows users to commission the system during start up when no protective gas supply is present. This should only be done when the area is safe. This function is only available through the menu and not the input switch. If unit powers down and powersback up, this enable will go back to NO.

**DANGER!**

This should be done only when the area is safe. Energizing the enclosure contacts before purging/cleaning the enclosure and safe enclosure pressure is dangerous.

BLUETOOTH SETTINGS:

BLUETOOTH SETTINGS	—	BLUETOOTH ENABLE	—	NO, YES
	—	BLUETOOTH ID	—	XXXXXXXXXXXXXXXXXXXX

The 6500 control unit is equipped with a Bluetooth chip that allows for wireless communication. Apps are available on our website, www.pepperl-fuchs.com, and can also be downloaded from most app sources.

**Note**

Compatible with Bluetooth 4.0.

SYSTEM RESET:

SYSTEM RESET	—	PASSWORD	—	NO, YES
--------------	---	----------	---	---------

System reset will disconnect and connect power to the EPCU to start the system. This will not reset any user-defined parameters.

FACTORY RESTORE:

FACTORY RESTORE	—	PASSWORD	—	NO, YES
-----------------	---	----------	---	---------

To implement the factory restore, the bypass word is required. This will restore the 6500 system to the factory settings. After implementing a factory restore, the unit will request to enter setup and bypass passwords.

BOOTLOADER LOAD SETTINGS:

BOOTLOADER MODE	—	PASSWORD	—	NO, YES
-----------------	---	----------	---	---------

Bootloader mode allows new firmware to be updated into the system. While the system is in bootload, it is important to not disconnect power. Bootloader may take up to 20 minutes to complete.

If the bootloader mode is initiated, and a PC is not connected, an error will occur. It can be cleared only by powering the 6500 control unit down and back up.

Instructions for bootloader will be available at www.pepperl-fuchs.com.

5. Statistics

Statistics Menu

STATISTICS
CURRENT ALARM
LAST ALARM
CURRENT FAULT
LAST FAULT
CLEAR STATISTICS
CLEAR FAULT
P+F 6500 REVISION
SETTINGS

Statistics

TEMPERATURES
MIN OVER PRESSURE
MAX OVER PRESSURE
MIN PURGE PRESSURE
MAX PURGE PRESSURE
LAST PURGE TIME
MIN PURGE FLOW
MAX PURGE FLOW
XPURGE6500 UP TIME
LAST SHUTDOWN
SHUTDOWN REASON
COM ERRORS

Alarms and faults

ALARMS

NONE
NO SAFE PRESSURE
MAX PRESSURE
LOW PRESSURE
INPUT 1 BROKE/SHORT
INPUT 2 BROKE/SHORT
py ENCL PWR ALARM
IMMEDIATE SHUTDWN
OVERLOAD SHUTDWN
LOST FLOW
K1 STILL ON
K2 STILL ON
TEMP INPUT 1
TEMP INPUT 2

FAULTS

NONE
CONTROL VALVE
INPUT 1
FLOW READING
CONFIG STORAGE
VENT 1 UPDATE
CRC MISMATCH
VALVE
VENT 1 FLOW UPDATE
TEMPERATURE UPDATE
INTERNAL RAM

Clear statistics

CLEAR STATISTICS	—	NO, YES	—	SETTING CORRECT Y/N
------------------	---	---------	---	---------------------

Clear fault

CLEAR FAULT	—	NO, YES	—	SETTING CORRECT Y/N
-------------	---	---------	---	---------------------

Pepperl+Fuchs 6500 revision

P+F 6500 REVISION	MAIN UNIT	HARDWARE REVISION	—	X.XX
		SOFTWARE REVISION	—	X.XX
		BOOTLOADER REVISION	—	X.XX
		SERIAL NUMBER	—	XXXXXXXXXXXX
		DEVICE TYPE	—	XX
		DEVICE ADDRESS	—	XX
		COM ERRORS TO EPCU	—	XXX
		TIME	—	XXXXX HOUR(S)
	USER INTERFACE	HARDWARE REVISION	—	X.XX
		SOFTWARE REVISION	—	X.XX
		BOOTLOADER REVISION	—	X.XX
		SERIAL NUMBER	—	XXXXXXXXXXXX
		DEVICE TYPE	—	XXXXX
		DEVICE ADDRESS	—	XXXXX
		COM ERRORS TO EPCU	—	XXXXX
		BLUETOOTH ID	—	XXXXXXXXXXXX
	VENT 1	HARDWARE REVISION	—	X.XX
		SOFTWARE REVISION	—	X.XX
		BOOTLOADER REVISION	—	X.XX
		SERIAL NUMBER	—	XXXXXXXXXXXX
		LOW PRESS CAL	—	XXXXX
		HIGH PRESS CAL	—	XXXXX
		LOW FLOW CAL	—	XXXXX
		HIGH FLOW CAL	—	XXXXX
		DEVICE TYPE	—	XX
		DEVICE ADDRESS	—	XX
		COM ERRORS TO EPCU	—	XXXXX
SENSOR 1 MIN TEMP	—	XXX °C or °F		
SENSOR 1 MAX TEMP	—	XXX °C or °F		

Settings

SETTINGS	—	ENCLOSURE VOLUME
	—	NUMB OF EXCHANGES
	—	VENT FLOW CONTROL
	—	VALVE CONTROL
	—	PURGE FLOW
	—	DILUTION FLOW SP
	—	MIN FLOW SP
	—	ENVIRONMENT
	—	MIN OVER PRESSURE
	—	MAX OVER PRESSURE
	—	SHUTDOWN TIMING
	—	UNLOCK DOOR TIMER
	—	OPERATION MODE

6. Product Identification

6.1. Specific Conditions of Use

6500 control unit

- The purge control unit has an operating temperature class of 135 °C (T4 temperature class). This temperature shall be considered when mounting the control unit to an enclosure.
- When the purge control unit is mounted to an enclosure, the complete unit shall be evaluated to IEC/EN 60079-2. See the certificate for appropriate edition of this standard.
- Intrinsically safe cables extending from the main enclosure must be provided with at least 0.25 mm insulation thickness per conductive core to maintain segregation between intrinsically safe circuits.
- The nonmetallic touchpad and display do not pose an electrostatic discharge hazard under normal use conditions. Use only water-damp cloth and allow to air dry for cleaning device. Do not use or install in high charge areas. See IEC 60079-32-1 for further information.
- In hazardous dust environment, regularly remove dust from the control unit enclosure and EPV vent to prevent excessive temperature rise. See certificate for full information.
- Cable glands and/or blanking elements used with this system shall be properly ATEX/IECEX rated for the environment they are being used in, with the proper temperature ratings. Only appropriately sized cable glands shall be fitted to the openings.
- For systems that incorporate the UIC in the lid of the enclosure, system shall not be mounted such that the UIC is facing up.
- Attention: The maximum cable length between the vent or UIC and the control unit is 245 ft (74.6 m). This is based on worst-case cable capacitance (C_{cable}) of 60 pf/ft (197 pf/m) and worst-case cable inductance of 0.2 $\mu\text{H}/\text{ft}$ (0.66 $\mu\text{H}/\text{m}$). Further operational reductions may apply. See manual.
- The relay contact circuits shall be externally fused at installation. Each circuit shall have a fuse that is rated for the voltage type being used (AC or DC) with a breaking capacity of at least 1500 A. The rating of the fuse for the enclosure power connections shall not exceed 11 A. for the Aux relay, it shall not exceed 3 A.

EPV-6500 pressure relief vent

- The EPV vent has an operating temperature class of 135 °C (T4 temperature class). This temperature shall be considered when mounted to an enclosure.
- When the purge control unit is mounted to an enclosure, the complete unit shall be evaluated to IEC/EN 60079-2: 2014 (Ed. 6).
- Cables used to connect to an EPV vent must be provided with at least 0.25 mm insulation thickness per conductive core to maintain segregation between intrinsically safe circuits.
- In hazardous dust environment, regularly remove dust from the EPV vent to prevent excessive temperature rise. See certificate for full information.
- In hazardous dust environment, the connector end of the vent shall be protected from direct exposure of a UV light source. See certificate for full information.
- Only EPV-6500-xx-xx vents can be connected to any certified 6500 control system.



DANGER!

Non-observance of conditions of safe use will result in personal injury or death.

6.2. Applied Standards



Note

See the certificates and/or the Declaration of Conformity for details on specific editions of the standards listed below.

IECEX and ATEX:

EN / IEC 60079-0
 EN / IEC 60079-2
 EN / IEC 60079-5
 EN / IEC 60079-7
 EN / IEC 60079-11
 EN / IEC 60079-31

6.3.Type Codes

6500 Control unit

6 5 0 0 - 0 1 - E X T 1 - P N O - L N O

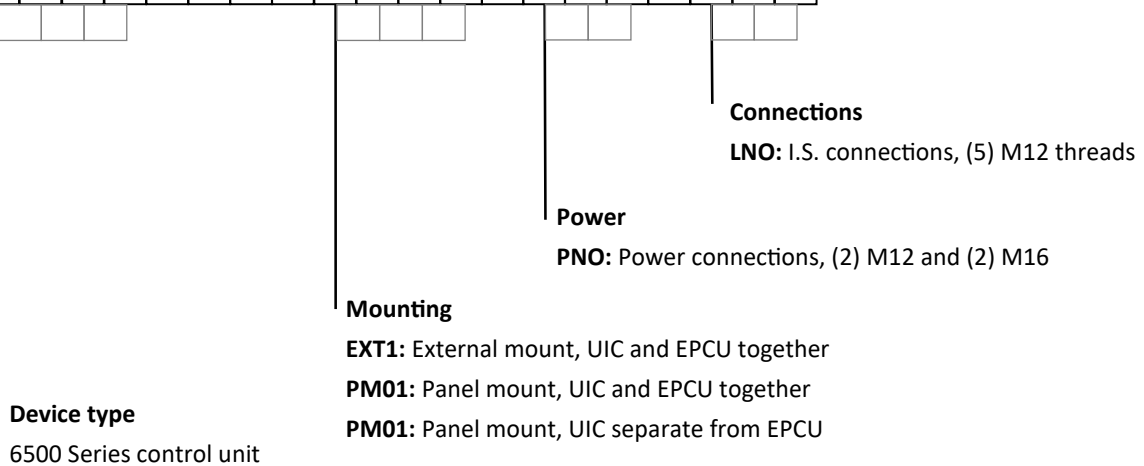

6500 UIC

6 5 0 0 - 0 1 - U I C - E X T

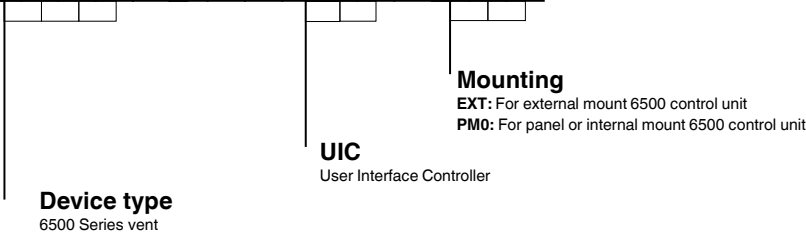

Note

6500-01-UIC... comes with standard 6500-01 control unit. Nomenclature is only used when ordering replacements.

EPV-6500 pressure relief vent

EPV - 6500 - AA - 01

Device type
EPV-6500 Series vents

Material

AA
Cap: marine-grade 5052 anodized aluminum
Body: marine-grade 6061T6 anodized aluminum





SS
Cap: 316L (UNS S31603) stainless steel
Body: marine-grade 6061T6 anodized aluminum

Flow





01: High flow rate, low enclosure pressure, high leakage rate
03: Medium flow rate, medium enclosure pressure, medium leakage rate
05: Low flow rate, high enclosure pressure, low leakage rate
07: Continuous flow, 7 l/min to 85 l/min (0.6 to 3.0 scfm)
08: Continuous flow, 71 l/min to 226 l/min (2.5 to 8.0 scfm)

6.4. Markings (Labelling)

Control Unit (6500-01-EXT)

<p>PEPPERL+FUCHS 68307 Mannheim, Germany / www.pepperl-fuchs.com</p> <p>Model 6500-01-EXT1-PNO-LNO 450 CF / 12.75 CM Max. Encl. Volume</p> <p>   </p> <p>Supply voltage: 20 to 30V $\overline{\text{---}}$, 0.6A or 100 to 250V \sim, 50/60 Hz, 0.2A</p> <p>Enclosure relays: 20 to 30V $\overline{\text{---}}$ or 100 to 250V \sim 8 A to 60°C / 5A to 70°C</p> <p>Auxiliary relay: 20 to 30V $\overline{\text{---}}$ or 100 to 250V \sim, 2A</p> <p>-See manual for other connection information -This device is factory sealed. Consult manual for repair instructions. -Cable glands and cables used for applications at 70°C require further consideration. See operation manual. WARNING: DO NOT OPEN WHEN ENERGIZED WARNING: DO NOT OPEN WHEN AN EXPLOSIVE ATMOSPHERE IS PRESENT</p>	<p>IECEX UL 16.0003 X / DNV 24.0017 X Ex eb ib q [ib Gb] [pxb Gb] IIC T4 Gb Ex ib tb [ib Db] [pxb Db] IIIC T135°C Db Ex eb ib q [ib Gb] [pyb Gb] IIC T4 Gb Ex ib tb [ib Db] [pyb Db] IIIC T135°C Db</p> <p>DEMKO 16 ATEX 1640X II 2 G Ex eb ib q [ib Gb] [pxb Gb] IIC T4 Gb II 2 D Ex ib tb [ib Db] [pxb Db] IIIC T135°C Db II 2 G Ex eb ib q [ib Gb] [pyb Gb] IIC T4 Gb II 2 D Ex ib tb [ib Db] [pyb Db] IIIC T135°C Db</p> <p>-20°C ≤ Ta ≤ 70°C</p> <p style="text-align: right;">IP66</p>
---	--

Control Unit (6500-01-PMXX)

<p>PEPPERL+FUCHS 68307 Mannheim, Germany / www.pepperl-fuchs.com</p> <p>Model 6500-01-PM01-PNO-LNO 450 CF / 12.75 CM Max. Encl. Volume</p> <p>   </p> <p>Supply voltage: 20 to 30V $\overline{\text{---}}$, 0.6A or 100 to 250V \sim, 50/60 Hz, 0.2A</p> <p>Enclosure relays: 20 to 30V $\overline{\text{---}}$ or 100 to 250V \sim 8 A to 60°C / 5A to 70°C</p> <p>Auxiliary relay: 20 to 30V $\overline{\text{---}}$ or 100 to 250V \sim, 2A</p> <p>-See manual for other connection information -This device is factory sealed. Consult manual for repair instructions. -Cable glands and cables used for applications at 70°C require further consideration. See operation manual. WARNING: DO NOT OPEN WHEN ENERGIZED WARNING: DO NOT OPEN WHEN AN EXPLOSIVE ATMOSPHERE IS PRESENT</p>	<p>IECEX UL 16.0003 X / DNV 24.0017 X Ex eb q [ib Gb] [pxb Gb] IIC T4 Gb Ex tb [ib Db] [pxb Db] IIIC T90°C Db Ex eb q [ib Gb] [pyb Gb] IIC T4 Gb Ex tb [ib Db] [pyb Db] IIIC T90°C Db</p> <p>DEMKO 16 ATEX 1640X II 2 G Ex eb q [ib Gb] [pxb Gb] IIC T4 Gb II 2 D Ex tb [ib Db] [pxb Db] IIIC T90°C Db II 2 G Ex eb q [ib Gb] [pyb Gb] IIC T4 Gb II 2 D Ex tb [ib Db] [pyb Db] IIIC T90°C Db</p> <p>-20°C ≤ Ta ≤ 70°C</p> <p style="text-align: right;">IP66</p>
---	--

DOCT-B3V4B • 02/2025

6500-01-UIC

PF PEPPERL+FUCHS
 68307 Mannheim Germany / www.pepperl-fuchs.com
Model 6500-01-UIC-PM0
 Part of DEMKO 16 ATEX 1640X
 II 2 G Ex ib [pxb Gb] IIC T4 Gb
 II 2 D Ex ib [pxb Db] IIIC T135°C Db
 II 2 G Ex ib [pyb Gb] IIC T4 Gb
 II 2 D Ex ib [pyb Db] IIIC T135°C Db
 Part of IECEx UL 16.0003X
 Ex ib [pxb Gb] IIC T4 Gb
 Ex ib [pxb Db] IIIC T135°C Db
 Ex ib [pyb Gb] IIC T4 Gb
 Ex ib [pyb Db] IIIC T135°C Db
 Part of DNV 24.0017 X -20°C ≤ Ta ≤ 70°C

IP66

EPV-6500 pressure relief vent

PF PEPPERL+FUCHS
 68307 Mannheim Germany / www.pepperl-fuchs.com
Model EPV-6500-AA-01
 450 CF / 12.75 CM Max. Encl. Volume
 DEMKO 15 ATEX 1622 X
 II 2 G Ex ib [pxb Gb] IIC T4 Gb
 II 2 D Ex ib [pxb Db] IIIC T135°C Db
 II 2 G Ex ib [pyb Gb] IIC T4 Gb
 II 2 D Ex ib [pyb Db] IIIC T135°C Db

IP66

IECEx UL 15.0147X
 Ex ib [pxb Gb] IIC T4 Gb
 Ex ib [pxb Db] IIIC T135°C Db
 Ex ib [pyb Gb] IIC T4 Gb
 Ex ib [pyb Db] IIIC T135°C Db
 DNV 24.0016 X
 -20°C ≤ Ta ≤ 70°C

6.4.1 CCC Certification Markings

6500-01-EXT
 CCC Certification number
 202032230400285

6500-01-PMXX
 CCC Certification number
 202032230400285

6500-MAN-DV-01
 CCC Certification number
 2021322307003982

6500 系列正压控制系统控制器
 Ex eb ib q [ib Gb] [pxb Gb] IIC T4 Gb
 Ex ib tb [ib Db] [pxb Db] IIIC T135°C Db
 Ex eb ib q [ib Gb] [pyb Gb] IIC T4 Gb
 Ex ib tb [ib Db] [pyb Db] IIIC T135°C Db
 警告：严禁带电开盖 产地：美国
 警告：有爆炸性气体时请勿打开
 KOSHA 19-AV4BO-0186X
 Ex e q ib [ib px] IIC T4

6500 系列正压控制系统控制器
 Ex eb q [ib Gb] [pxb Gb] IIC T4 Gb
 Ex tb [ib Db] [pxb Db] IIIC T90°C Db
 Ex eb q [ib Gb] [pyb Gb] IIC T4 Gb
 Ex tb [ib Db] [pyb Db] IIIC T90°C Db
 警告：有爆炸性气体时请勿打开
 警告：严禁带电开盖 产地：美国
 KOSHA 19-AV4BO-0186X
 Ex e q ib [ib px] IIC T4

PF PEPPERL+FUCHS
 68307 Mannheim Germany / www.pepperl-fuchs.com
6500-MAN-DV-01
 II 3 G
 II 3 D
 Ex ia IIC T6 Gb
 P ≤ 1.6W; Ui ≤ 28V; Ii ≤ 115mA
 Ex ia IIB T6 Gb
 P ≤ 1.6W; Ui ≤ 32V; Ii ≤ 195mA
 Li-0; Ci-0 -40°C ≤ Ta ≤ +50°C
 电磁阀
 产地：美国

6500-01-UIC
 CCC Certification number
 202032230400285

EPV-6500 Pressure relief vent
 CCC Certification number
 2020322304002499

6500 系列正压通风控制系统控制器用户接口
 Ex ib [pxb Gb] IIC T4 Gb
 Ex ib [pxb Db] IIIC T135°C Db
 Ex ib [pyb Gb] IIC T4 Gb
 Ex ib [pyb Db] IIIC T135°C Db
 产地：美国
 KOSHA 19-AV4BO-0186X
 Ex ib [px] IIC T4

EPV-6500 系列减压阀
 Ex ib [pxb Gb] IIC T4 Gb
 Ex ib [pxb Db] IIIC T135°C Db
 Ex ib [pyb Gb] IIC T4 Gb
 Ex ib [pyb Db] IIIC T135°C Db
 产地：美国
 KOSHA 19-AV4BO-0189X
 Ex ib [px] IIC T4

7. Product Lifetime Care

7.1. Maintenance and Repair

1. Purge and pressurization system does not require special maintenance except cleaning of pneumatic filters, when used, and normal periodic functional checks, including pressure and flow readings within specifications contained in this manual. When checking whether the pressure and flow measurements of the EPV-6500 are within specifications, use calibrated equipment to determine measurements or contact a P+F representative or the factory to send back the EPV-6500 vent for pressure and flow verification.



WARNING!

The 6500 control unit EPCU is powder-filled and is not user-servicable. This unit must be sent back to the factory for replacement/repair.

2. The 6500 purge and pressurization system, when operated in conjunction with a hazardous area, must not be modified. If there is a defect, the product may need to be replaced. Repairs must be performed only by a Pepperl+Fuchs specialist who is specially trained and authorized to repair the defect.
3. Any replaceable fuses must be replaced with specific fuse ratings and type as written in this manual under specifications.
4. When servicing, installing, and commissioning, the area must be free of all combustible material and/or hazardous explosive gas. Only the terminal compartment of the control unit is accessible to the user. Not under any circumstances shall the control unit, user interface, or vent be taken apart.
5. Any cable glands that require replacement shall be replaced with the same model or another approved cable gland that meets the area classification.
6. For the 6500-01-EXT1-... control unit, the cable from the user interface must be placed in the control unit on the I.S. side of the physical barrier.

Contact Pepperl+Fuchs customer service for an RMA (Return Merchandise Authorization).

7.2. Troubleshooting

The 6500 purge controller can indicate certain alarm and fault conditions when they happen. The alarm condition is indicated on the display under the Alarm/Fault LED and will blink for alarm and solid for fault. The alarm will not disengage enclosure contacts if they are on but can be directed to the AUX alarm contacts. The fault will disengage enclosure contacts.

The following table explains the alarm descriptions:

Alarm	Description	Cause
NO SAFE PRESSURE	Enclosure pressure is below minimum safe pressure.	- No purge supply - Enclosure leakage too large
MAX PRESSURE	Enclosure pressure is above the maximum pressure allowed.	- Purge supply pressure too high - EPV-6500 vent is blocked or not installed
LOW PRESSURE	Enclosure pressure is below the alarm pressure, but above the min safe press.	- Purge supply capacity is insufficient - Enclosure is starting to leak more
INPUT 1 BROKE/ SHORT	When SRM is selected, then a wire is broken or shorted going to the switch input.	- SRM is selected and not installed on the switch input - Broken or shorted wire to switch/SRM or proximity sensor
PY ENCL PWR ALARM	Activates only when 'py' selected and enclosure pressure drops below minimum safe pressure	- No purge supply - Enclosure leakage too large
IMMEDIATE SHUTDOWN	Immediate shutdown has to be active to indicate an alarm.	Immediate shutdown has been activated.
OVERLOAD SHUTDOWN	Overload shutdown has to be active to indicate an alarm.	Overload shutdown has been activated.
LOST FLOW	During purging, if EPV-6500 vent detects a flow lower than expected, alarm is activated.	- Purge supply capacity is not large enough - During purging, excess leakage is introduced to cause drop in flow
ENCLS PWR RELAY	Enclosure power relays are working properly—two sets of contacts for monitoring condition of contacts.	- No power connected to the input of the contacts - Contacts are welded.
TEMP INPUT 1	Temperature input 1 is active	- The temperature of the RTD is outside the limits of the TEMP INPUT 1
TEMP INPUT 2	Temperature input 2 is active	- The temperature of the RTD is outside the limits of the TEMP INPUT 2

The following table explains the fault descriptions:

Fault	Description	Cause
INPUT 1	Input 1 is not functioning properly.	- Power for input is defective - Defective EPCU
FLOW READING	Flow reading from EPV-6500 is corrupted or not available.	Flow readings are outside the range of the EPV-6500 vent being used.
CONFIG STORAGE	EPCU fault	- EPCU fault - Defective EPCU
VENT 1 UPDATED	EPV-6500 vent is not communicating	- No EPV-6500 vent connected to controller - One or more of the connections from EPV-6500 vent to controller is not correct or not connected. - EPV-6500 fault
CRC MISMATCH	EPCU fault	Mismatch of instruction set for controller–defective EPCU
VALVE	No power to the valve output	EPCU fault–defective EPCU
VENT 1 FLOW UPDATE	EPV-6500 is getting power but communication is not correct.	- One or more of the connections from EPV-6500 vent to controller is not correct or not connected. - EPV-6500 fault
TEMPERATURE UPDATE	RTD temperature reading is out of spec or not reading.	- RTD is defective - No RTD connected to 6500 controller input
INTERNAL RAM	EPCU memory fault	EPCU fault

7.3. Dismantling and Decommissioning

Abide by all local and any other code requirements for disposing of electronic equipment. When disposing of any component of the 6500, certification labels shall be marked “VOID” across the full expanse of the label.

Your automation, our passion.

Explosion Protection

- Intrinsic Safety Barriers
- Signal Conditioners
- FieldConnex® Fieldbus
- Remote I/O Systems
- Electrical Ex Equipment
- Purge and Pressurization
- Industrial HMI
- Mobile Computing and Communications
- HART Interface Solutions
- Surge Protection
- Wireless Solutions
- Level Measurement

Industrial Sensors

- Proximity Sensors
- Photoelectric Sensors
- Industrial Vision
- Ultrasonic Sensors
- Rotary Encoders
- Positioning Systems
- Inclination and Acceleration Sensors
- Fieldbus Modules
- AS-Interface
- Identification Systems
- Displays and Signal Processing
- Connectivity