



Loop detector LC10-1-D 230 VAC

- Sensor system for vehicle detection
- Complete control interface for inductive loops laid beneath the surface
- Reliable detection with long service life
- Various operating modes available
- Boost function for increasing sensitivity
- Test function
- Version with 1 loop channel

Universal sensor system for detecting vehicles



Function

Together with the inductive loops laid beneath the surface, the loop detectors form a universal sensor system for detecting vehicles. Vehicles that enter the inductive loop change the resonant frequency. The microprocessor in the loop detector measures and analyzes this frequency change. The analysis is automatically and periodically adjusted to the respective loop, ensuring that any changes in the loop inductance caused by temperature, humidity, or component age are automatically compensated for.

Dimensions

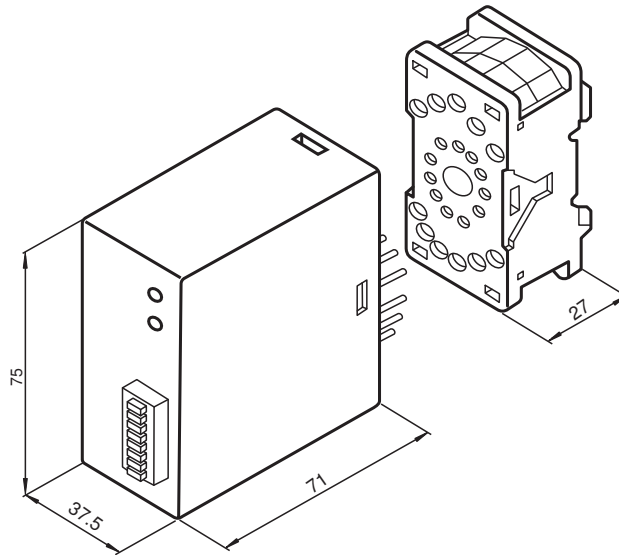

Technical Data

General specifications		
Marking		CE
Operating mode		Pulsed and continuous signal
Functional safety related parameters		
MTTF _d		306 a
Mission Time (T _M)		20 a
Indicators/operating means		
Control elements		DIP-switch
Switching state		LED
Electrical specifications		
Operating voltage	U _B	230 V AC (galvanically isolated from loop)
Ripple		-15 %/+10 %
Power consumption	P ₀	1.6 VA
Calibration time		2 s
Loop inductivity		100 ... 1000 μH
Loop frequency		20 ... 120 kHz
Input		
Number of channels		1
Output		
Output type		relay
Switching voltage		250 V AC
Switching current		6 A
Pulse length		period or 800 ms Pulse
Response time		100 ms
Ambient conditions		
Ambient temperature		-20 ... 70 °C (-4 ... 158 °F)
Storage temperature		-40 ... 70 °C (-40 ... 158 °F)
Mechanical specifications		
Degree of protection		IP30
Connection		Plug socket ; 11-pin Terminal connection ≤ 1.5 mm ²

Connection Assignment

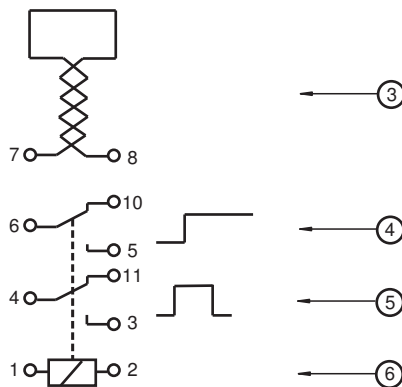

Number	Explanation	Connector terminals
3	Loop connection	7/8
4	Signal output, maintained contact	5/6 = NO 6/10 = NC
5	Signal output, pulse contact	3/4 = NO 4/11 = NC
6	Operating voltage	1/2

Release date: 2020-10-08 Date of issue: 2020-10-08 Filename: 190924_eng.pdf

Assembly

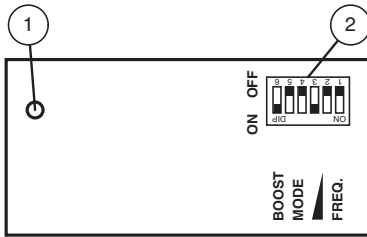

1	LED display
2	DIP switch

Characteristic Curve

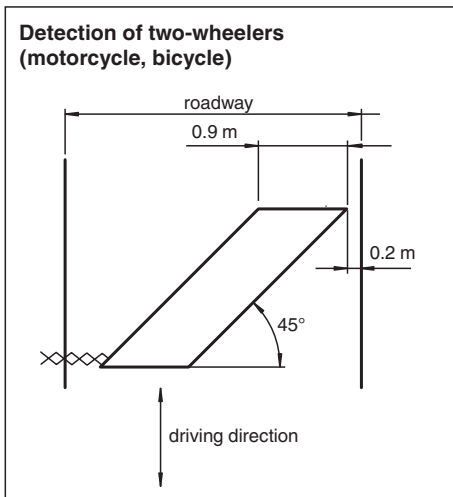
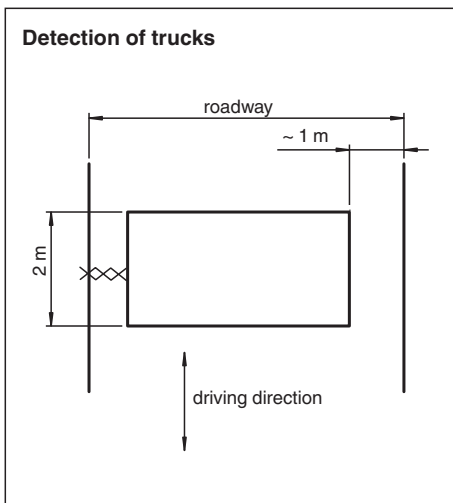
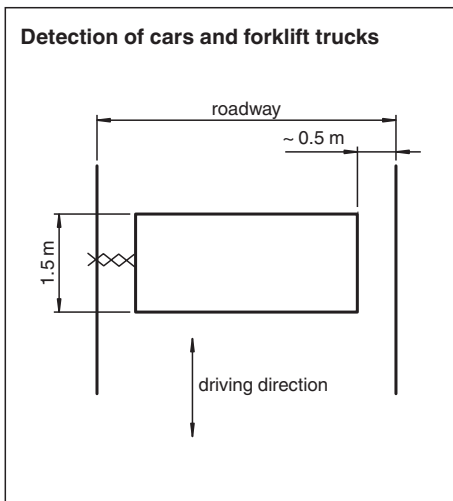

Release date: 2020-10-08 Date of issue: 2020-10-08 Filename: 190924_eng.pdf

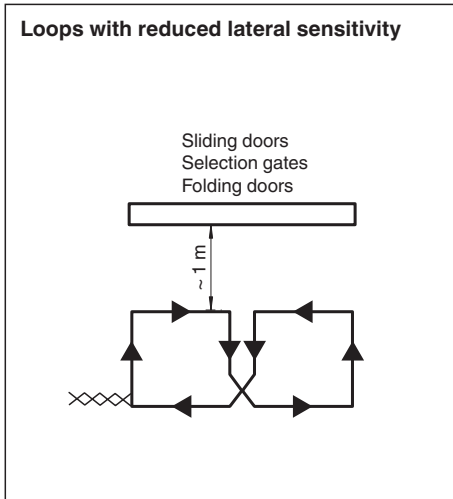

Application

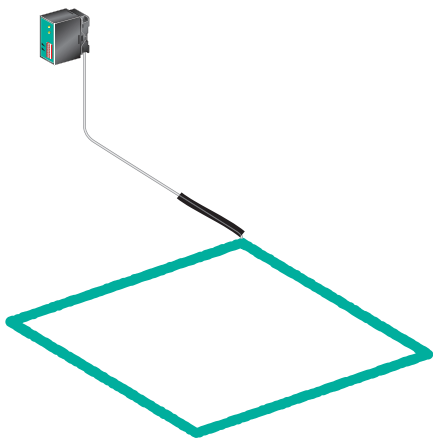

Release date: 2020-10-08 Date of issue: 2020-10-08 Filename: 190924_eng.pdf

Refer to "General Notes Relating to Pepperl+Fuchs Product Information".

Pepperl+Fuchs Group
www.pepperl-fuchs.com

USA: +1 330 486 0001
fa-info@us.pepperl-fuchs.com

Germany: +49 621 776 1111
fa-info@de.pepperl-fuchs.com

Singapore: +65 6779 9091
fa-info@sg.pepperl-fuchs.com

Settings:

Sensitivity:

The response sensitivity of the loop detector can be set in three stages by switches 3 and 4.

Switch 3	Switch 4	Sensitivity
OFF	ON	low
ON	OFF	medium
ON	ON	high

In the switch position "OFF", "OFF" the loop evaluation is switched off.

Frequency switches:

The loop frequency can be set in four stages using the switches 1 and 2.

Switch 1	Switch 2	Frequency
OFF	OFF	Basic frequency f
ON	OFF	f - 10 %
OFF	ON	f - 15 %
ON	ON	f - 20 %

After actuation of the frequency switches 1 and 2 the loop must be readjusted with switches 3 and 4 set to "OFF", "OFF".

Operating mode switches:

The following operating modes can be set with switches 5 and 6:

Switch 5	Switch 6	Result
OFF	-	Pulse (0.8 s) when loop is allocated
ON	-	Pulse (0.8 s) when loop is abandoned
-	ON	Increased sensitivity (Boost)

The increased sensitivity (Boost) is used for the detection of vehicles with high body assemblies, e.g. HGVs.

Automatic adjustment:

When the operating voltage is applied to the device automatic adjustment with the loop takes place. The output relays are switched in the switch position "Loop not allocated". The adjustment takes 2 s, the device is then ready for operation.

Automatic adjustment also takes place when both sensitivity switches 3 and 4 are set to "OFF" and then set to another switch position.

Indications:

LED signals the allocation state of the loop (Loop allocated = LED On). A fault in the loop due to a short-circuit or lead breakage and loop inductance outside the permissible range is indicated by flashing of LED.

Test function:

The loop detector is provided with an integrated test function, which enables the loop frequency and sensitivity to be optimally set without additional devices or instrumentation.

Indication of the recommended sensitivity:

The vehicle must be driven onto the loop. The loop detector measures and stores the frequency change. When switches 3 and

Release date: 2020-10-08 Date of issue: 2020-10-08 Filename: 190924_eng.pdf

4 are changed over the recommended sensitivity is indicated by flashing of the LED.

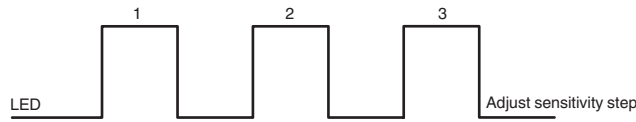

Measurement of the loop frequency:

The loop frequency can be measured via the LED. Set switches 3 and 4 from "OFF" to "ON". The LED indicates the loop frequency via a signal sequence:

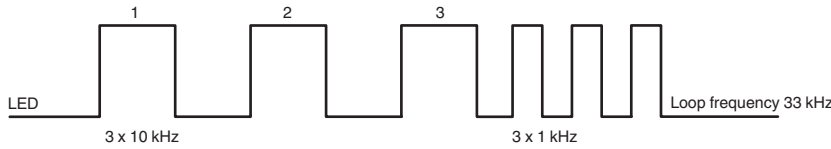

Loop fault:

In the event of lead breakage or short-circuit the LED flashes continuously and the switch contact reverts to the "Loop allocated" state.

Function Principle

The loop detectors are control units that are fully functional without the need for any other auxiliary equipment once the power supply and an inductive loop have been connected. The inductive loop laid below the surface forms the inductor of a high-frequency oscillating circuit. The metal parts of a vehicle that enters or is located in this wired loop cause the frequency of the oscillation circuit to change. This frequency change is analyzed by the loop detector, and the outputs, which are zero-potential relay contacts, can switch. The switching outputs are relay contacts with a high switching power that can directly control contactors, valves and alternating current motors.

The dimensions of the detection area can be adjusted by changing the size and shape of the inductive loops.

Application

- Selective vehicle detection
- Opening impulse sensor for automatic gates and barrier systems
- Presence checks for vehicles
- Controlling traffic light and vehicle detection systems
- Ticket detection in parking garages
- Managing tasks in automatic conveyor systems

Release date: 2020-10-08 Date of issue: 2020-10-08 Filename: 190924_eng.pdf

Refer to "General Notes Relating to Pepperl+Fuchs Product Information".