

Resistance Repeater KCD2-RR-Ex1

SIL 2

- 1-channel isolated barrier
- 24 V DC supply (Power Rail)
- Resistance and RTD input (Pt100, Pt500, Pt1000)
- Resistance output
- Accuracy 0.1 %
- Line fault detection (LFD) for Pt100
- Housing width 12.5 mm
- Up to SIL 2 acc. to IEC 61508



Function

This isolated barrier is used for intrinsic safety applications. It transfers resistance values of RTDs or potentiometers from hazardous areas to safe areas. A 2-, 3-, or 4-wire technique is available depending on the required accuracy. The input card of the control system measures the same load as if it were connected directly to the resistance in a hazardous area.

Connection

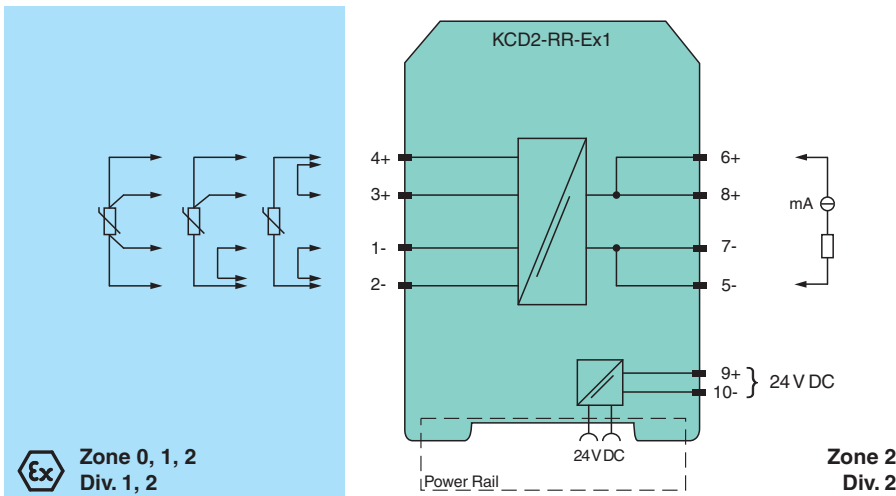

Ex Zone 0, 1, 2
Div. 1, 2

Technical Data

General specifications

Signal type Analog input

Functional safety related parameters

Safety Integrity Level (SIL) SIL 2

Supply

Connection	Power Rail or terminals 9+, 10-	
Rated voltage	U_r	19 ... 30 V DC
Ripple	within the supply tolerance	
Rated current	I_r	< 20 mA
Power consumption	0.35 W (24 V and 1 mA sense current)	

Input

Connection side field side

Release date: 2020-09-23 Date of issue: 2020-09-23 Filename: 286931_eng.pdf

Refer to "General Notes Relating to Pepperl+Fuchs Product Information".

Pepperl+Fuchs Group
www.pepperl-fuchs.com

USA: +1 330 486 0002
pa-info@us.pepperl-fuchs.com

Germany: +49 621 776 2222
pa-info@de.pepperl-fuchs.com

Singapore: +65 6779 9091
pa-info@sg.pepperl-fuchs.com

PEPPERL+FUCHS

Technical Data

Connection	terminals 1, 2, 3, 4
Line fault detection	yes, at Pt100
Lead resistance	≤ 10 % of resistance value
Transmission range	0 ... 10 mA
Available voltage	9 V
Line fault detection	8 nA
Output	
Connection side	control side
Connection	terminals 5-, 7-, 6+, 8+
Current	0 ... 10 mA
Available voltage	0 ... 4.2 V
Fault signal	< 10 Ω or > 400 Ω, depending on lead disconnected (measuring current ≤ 1 mA) > 400 Ω, terminal 3 lead disconnected in 2-/4-wire (measuring current ≤ 0.3 mA)
Transfer characteristics	
Accuracy	0.1 %
Deviation	4-wire $I_m \geq 1 \text{ mA}$: ±0.1 % of R_m or ± 0.1 Ω (the larger value is applicable) $I_m < 1 \text{ mA}$: accuracy reduces in proportion to I_m . e. g. $I_m = 0.1 \text{ mA}$: ± 1 % of R_m or 1 Ω (the larger value is applicable). 3-wire $I_m \geq 1 \text{ mA}$: (±0.1 % - 0.1 Ω Offset) or ± 0.2 Ω (the larger value is applicable) $I_m < 1 \text{ mA}$: accuracy reduces in proportion to I_m . e. g. $I_m = 0.1 \text{ mA}$: (±1 % - 0.1 Ω Offset) or ± 1.1 Ω (the larger value is applicable)
Influence of ambient temperature	$I_m \geq 1 \text{ mA}$, $R_m \geq 100 \Omega$: 0.01 %/K in the range -20 ... +60 °C (253 ... 333 K) $I_m < 1 \text{ mA}$ or $R_m < 100 \Omega$: temperature stability reduces in proportion to I_m or R_m
Rise time	signal response time ≤ 2 ms (10 ... 90 %) response to application of I_m : $R_m > 50 \Omega$ and $I_m < 5 \text{ mA}$: < 5ms response to application of I_m : $R_m > 30 \Omega$ and $I_m < 5 \text{ mA}$: < 10ms response to application of I_m : $R_m > 18 \Omega$ and $I_m < 5 \text{ mA}$: < 20ms
Galvanic isolation	
Input/Output	reinforced insulation acc. to EN 50178, rated insulation voltage 300 V _{eff}
Input/power supply	reinforced insulation acc. to EN 50178, rated insulation voltage 300 V _{eff}
Output/power supply	functional insulation, rated insulation voltage 50 V AC
Indicators/settings	
Display elements	LED
Control elements	DIP-switch
Configuration	via DIP switches
Labeling	space for labeling at the front
Directive conformity	
Electromagnetic compatibility	
Directive 2014/30/EU	EN 61326-1:2013 (industrial locations)
Conformity	
Electromagnetic compatibility	NE 21:2011
Degree of protection	IEC 60529:2001
Protection against electrical shock	UL 61010-1
Ambient conditions	
Ambient temperature	-20 ... 60 °C (-4 ... 140 °F)
Mechanical specifications	
Degree of protection	IP20
Connection	screw terminals
Mass	approx. 100 g
Dimensions	12.5 x 114 x 124 mm (0.5 x 4.5 x 4.9 inch), housing type A2
Mounting	on 35 mm DIN mounting rail acc. to EN 60715:2001
Data for application in connection with hazardous areas	
EU-type examination certificate	BASEEFA 10 ATEX 0061
Marking	⊕ II (1)G [Ex ia Ga] IIC ⊕ II (1)D [Ex ia Da] IIIC ⊕ I (M1) [Ex ia Ma] I

Release date: 2020-09-23 Date of issue: 2020-09-23 Filename: 286931_eng.pdf

Technical Data







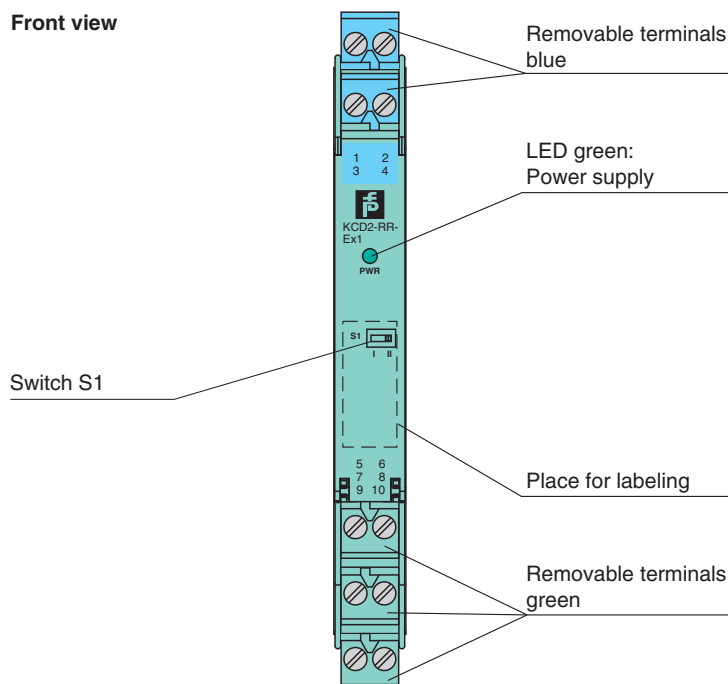



Input		[Ex ia Ga] IIC, [Ex ia Da] IIIC, [Ex ia Ma] I
Voltage	U_o	12.4 V
Current	I_o	17.4 mA
Power	P_o	54 mW
Supply		
Maximum safe voltage	U_m	253 V (Attention! The rated voltage can be lower.)
Output		
Maximum safe voltage	U_m	253 V (Attention! The rated voltage can be lower.)
Certificate		BASEEFA 10 ATEX 0062X
Marking		Ⓔ II 3G Ex ec IIC T4 Gc
Galvanic isolation		
Input/Output		safe electrical isolation acc. to IEC/EN 60079-11:2012, voltage peak value 375 V
Input/power supply		safe electrical isolation acc. to IEC/EN 60079-11:2012, voltage peak value 375 V
Directive conformity		
Directive 2014/34/EU		EN IEC 60079-0:2018 , EN 60079-7:2015+A1:2018 , EN 60079-11:2012
International approvals		
FM approval		
Control drawing		116-0129 (cFMus)
UL approval		
Control drawing		116-0332 (cULus)
IECEx approval		IECEx BAS 10.0024 IECEx BAS 10.0025X
Approved for		[Ex ia Ga] IIC , [Ex ia Da] IIIC , [Ex ia Ma] I , Ex ec IIC T4 Gc
General information		
Supplementary information		Observe the certificates, declarations of conformity, instruction manuals, and manuals where applicable. For information see www.pepperl-fuchs.com .
Accessories		
Optional accessories		- power feed module KFD2-EB2(.R4A.B)(.SP) - universal power rail UPR-03(-M)(-S) - profile rail K-DUCT-BU(-UPR-03) - insertion bridge EBP 2- 5

Assembly

Front view



Accessories

	KFD2-EB2	Power Feed Module
	KFD2-EB2.R4A.B	Power feed module, redundant supply
	KFD2-EB2.R4A.B.SP	Power feed module with spring terminals, redundant supply
	KFD2-EB2.SP	Power feed module with spring terminals
	UPR-03	Universal Power Rail with end caps and cover, 3 conductors, length: 2 m
	UPR-03-M	Universal Power Rail with end caps and cover, 3 conductors, length: 1,6 m
	UPR-03-S	Universal Power Rail with end caps and cover, 3 conductors, length: 0.8 m
	K-DUCT-BU	
	K-DUCT-BU-UPR-03	Profile rail with UPR-03- * insert, 3 conductors, wiring comb field side blue
	EBP 2- 5	

Additional Information

Function

When a signal converter, a DCS or PLC is connected to terminals 5, 6, 7, and 8 (control side), the measuring current is transferred to terminals 2 and 4 (field side). The resulting voltage at terminals 1, and 3 is transferred to terminals 5, 6, 7, and 8.

In the case of fast multiplex input cards, transmission problems might be experienced in connection with low resistance values and/or high sensor currents. For data see rise time.

The quoted accuracy is for a 4-wire technique connection. The accuracy in 3-wire technique will depend on the matching of the line resistance.

Connection types control side (safe area)

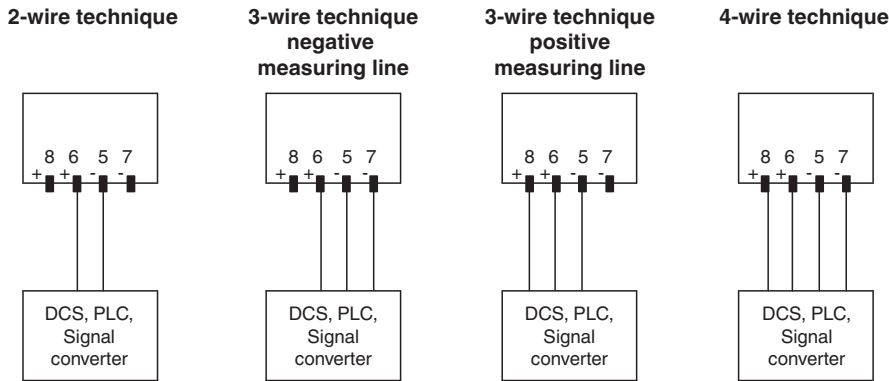

Connection types field side (hazardous area)

The resistance in the hazardous area can be measured with a 2-, 3- or 4-wire technique.

- 2-wire technique: Link terminals 1 and 2 and terminals 3 and 4. Connect the resistance to terminal 4 and terminal 2. Switch S1 in the position II.
- 3-wire technique: Link terminals 1 and 2. Connect the resistance to terminals 3 and 4 and terminal 2. Switch S1 in the position I.
- 4-wire technique: Connect the resistance to terminals 3 and 4 and terminals 1 and 2. Switch S1 in the position II.

Measurement range

The resistance repeater can convey a maximum of 10 mA and a maximum of 7 V. The maximum connectable resistance value can be calculated with the following equations

- Resistance value = 4.2 V / measuring current
- Resistance value = 9 V / measuring current - 758 Ω

Use the smaller of these two resistance values as maximum allowed load.

The measuring current is determined by control.

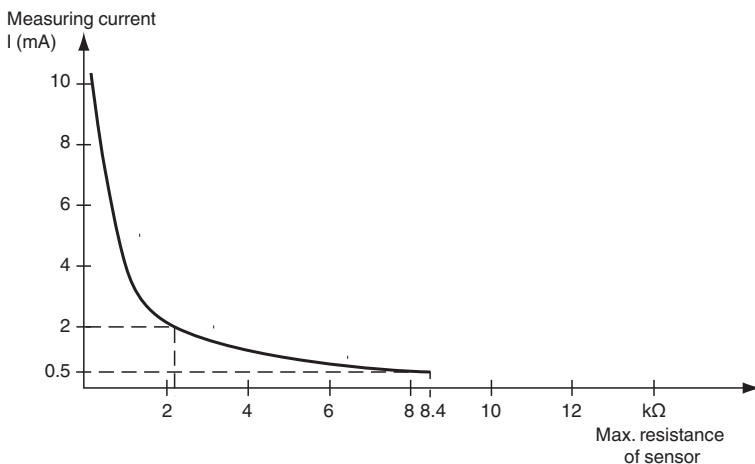

An example of the maximum transferable resistance value:

Release date: 2020-09-23 Date of issue: 2020-09-23 Filename: 286931_eng.pdf

- 8.4 k Ω at 0.5 mA measuring current
- 2.1 k Ω at 2 mA measuring current

Line Fault Detection (LFD)

The output will indicate less than 10 Ω or greater than 400 Ω for a lead breakage at terminals 1, 2, 3 or 4 for measuring current of less than or equal to 1 mA i.e. out of range for Pt100.