



Model Number

UB4000-30GM-H3

Single head system

Features

- **Separate evaluation**
- **Direct detection mode**

Diagrams

Characteristic response curves

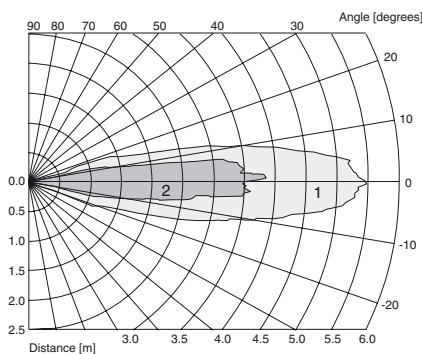

Curve 1: flat surface 100 mm x 100 mm
Curve 2: round bar, Ø 25 mm

Technical data

General specifications

Sensing range	500 ... 4000 mm
Unusable area	0 ... 500 mm
Standard target plate	100 mm x 100 mm
Transducer frequency	approx. 85 kHz

Electrical specifications

Operating voltage U_B	10 ... 30 V DC, ripple 10 % _{SS}
No-load supply current I_0	≤ 30 mA

Input

Input type	1 pulse input for transmitter pulse, activation through open collector npn < 1 V: emitter active, > 4 V: emitter inactive
Pulse length	40 ... 500 µs
Pause length	≥ 50 x pulse length

Output

Output type	1 pulse output for echo propagation time, high-active, short-circuit proof
Signal level	1-level: ≥ $U_B - 3 V$; ≤ 10 mA level 0: ≤ 1 V; ≤ 0,1 mA
Temperature influence	the echo propagation time: 0.17 % / K

Ambient conditions

Ambient temperature	-25 ... 70 °C (-13 ... 158 °F)
Storage temperature	-40 ... 85 °C (-40 ... 185 °F)

Mechanical specifications

Protection degree	IP65
Connection	2 m PVC cable 0.75 mm ²
Material	
Housing	nickel plated brass; plastic components: PBT
Transducer	epoxy resin/hollow glass sphere mixture; polyurethane foam
Mass	327 g

Compliance with standards and directives

Standard conformity	
Standards	EN 60947-5-2:2007 IEC 60947-5-2:2007

Approvals and certificates

UL approval	cULus Listed, General Purpose
CSA approval	cCSAus Listed, General Purpose

Dimensions

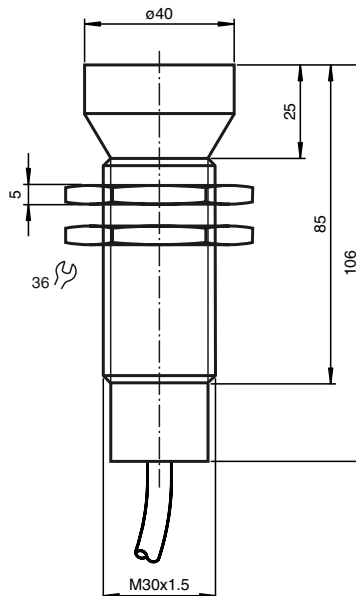

Release date: 2013-02-26 14:50 Date of issue: 2013-02-26 032885_eng.xml

Electrical Connection

Standard symbol/Connection:
(Transceiver)

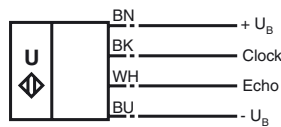

BK = Emitter pulse input
WH = Echo propagation time output

Accessories

BF 30
Mounting flange, 30 mm

BF 5-30
Universal mounting bracket for cylindrical sensors with a diameter of 5 ... 30 mm

Function

The sensing range is determined in the downstream evaluation electronics such as PLC modules or other existing evaluation units.

The object distance in pulse-echo mode is obtained from the echo time Δt . The emission of an ultrasonic pulse starts simultaneously with the falling slope of the clock input signal.

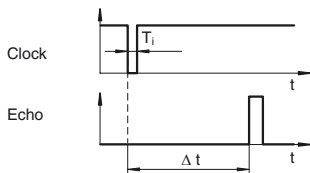

We recommend the usage of a npn-transistor to trigger the sensors clock input. The sensors clock input is connected to the $+U_B$ potential internally by means of a pull up resistor.

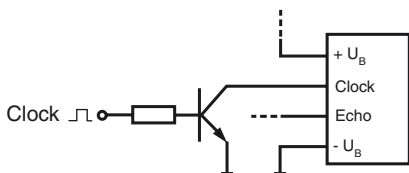

- 1) The unusable area (blind range) BR depends on the pulse duration T_i .
The unusable area reaches a minimum with the shortest pulse duration.
- 2) The sensors detection range depends on the pulse duration T_i .
With pulse duration $<$ typical pulse duration, the sensors detection range may be reduced.