



Label Carrier

ZH-Z.BT

- Accessory Zener Barriers
- For equipotential bonding via the standard rail

Label Carrier

Assembly

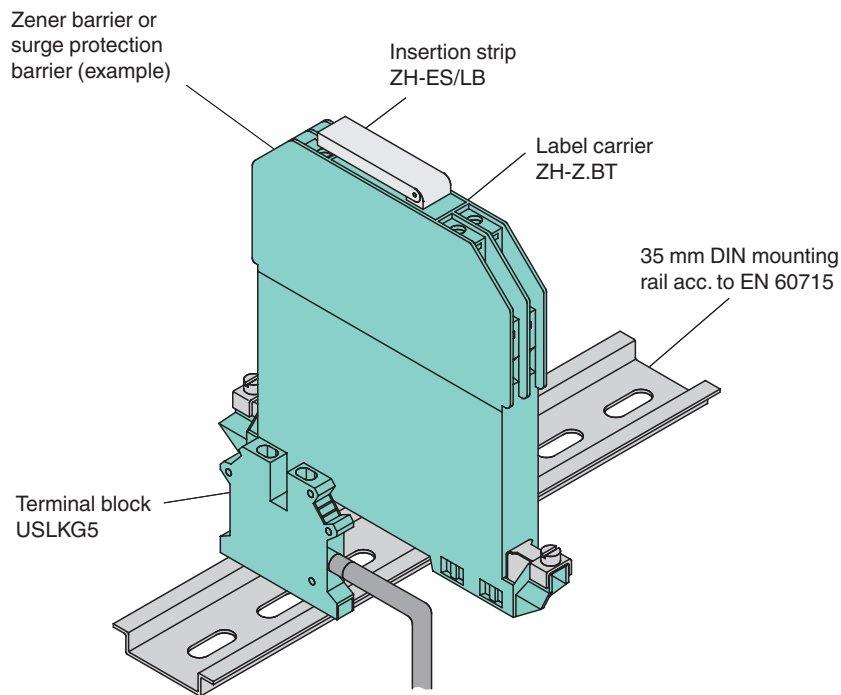

Release date: 2022-10-19 Date of issue: 2022-10-19 Filename: 033209_eng.pdf

Refer to "General Notes Relating to Pepperl+Fuchs Product Information".

Pepperl+Fuchs Group
www.pepperl-fuchs.com

USA: +1 330 486 0002
pa-info@us.pepperl-fuchs.com

Germany: +49 621 776 2222
pa-info@de.pepperl-fuchs.com

Singapore: +65 6779 9091
pa-info@sg.pepperl-fuchs.com

 **PEPPERL+FUCHS**