

Features

- 4-channel isolated barrier
- 24 V DC supply
- Dry contact or NAMUR inputs
- Relay output
- Fault indication output
- Line fault detection (LFD)
- Reversible mode of operation

Function

This isolated barrier is used for intrinsic safety applications. The device transfers digital signals (NAMUR sensors/mechanical contacts) from a hazardous area to a safe area. Each proximity sensor or switch controls two relay outputs for the safe area load. The normal output state of outputs can be reversed using switch WR. Switches LK and LB enables or disables line fault detection of the field circuit. During an error condition, the relay reverts to its de-energized state and the LEDs indicate the fault according to NAMUR NE44.

Assembly

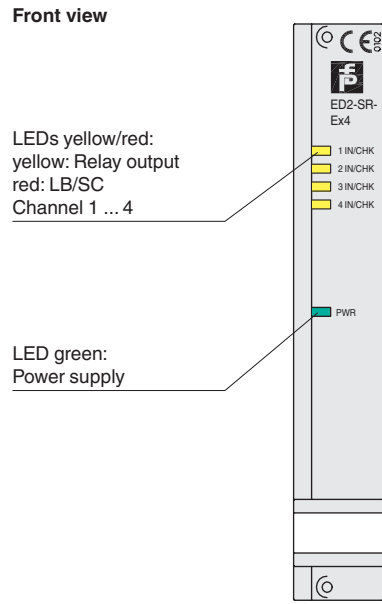

Connection

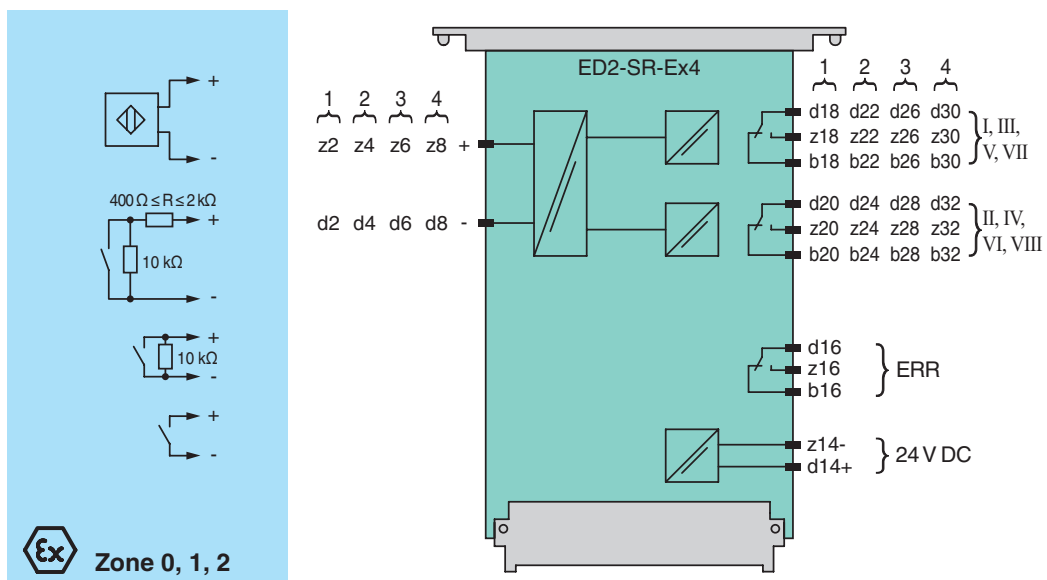

Release date 2012-05-22 12:20 Date of issue 2012-05-22 037890_eng.xml

General specifications		
Signal type	Digital Input	
Supply		
Connection	d14+, z14-	
Rated voltage	20 ... 30 V DC	
Ripple	≤ 10 %	
Rated current	≤ 100 mA	
Input		
Connection	channel 1: d2-, z2+ channel 2: d4-, z4+ channel 3: d6-, z6+ channel 4: d8-, z8+	
Rated values	acc. to EN 60947-5-6 (NAMUR), see system description for electrical data	
Open circuit voltage/short-circuit current	approx. 8 V DC / approx. 8 mA	
Switching point/switching hysteresis	1.2 ... 2.1 mA / approx. 0.2 mA	
Line fault detection	breakage I ≤ 0.1 mA , short-circuit I > 6 mA	
Pulse length/pulse interval	≥ 0.5 ms / ≥ 0.5 ms	
Output		
Connection	channel 1: output I: b18, d18, z18, output II: b20, d20, z20 channel 2: output III: b22, d22, z22, output IV: b24, d24, z24 channel 3: output V: b26, d26, z26, output VI: b28, d28, z28 channel 4: output VII: b30, d30, z30, output VIII: b32, d32, z32	
Output	signal ; relay	
Contact loading	70 V AC/0.5 A/cos φ > 0.7; 40 V DC/2 A resistive load/max. 60 W	
Energized/De-energized delay	< 4 ms / < 4 ms	
Mechanical life	10 ⁶ switching cycles	
Error message output		
Connection	d16, z16, b16	
Output	fault signal ; relay	
Contact loading	70 V AC/0.5 A/cos φ > 0.7; 40 V DC/2 A resistive load/max. 60 W	
Energized/De-energized delay	< 4 ms / < 4 ms	
Mechanical life	10 ⁶ switching cycles	
Transfer characteristics		
Switching frequency	25 Hz , no continuous operation	
Electrical isolation		
Output/power supply	basic insulation acc. to DIN EN 50178, rated insulation voltage of 50 V _{eff}	
Output/Output	basic insulation acc. to DIN EN 50178, rated insulation voltage of 50 V _{eff}	
Directive conformity		
Electromagnetic compatibility		
Directive 2004/108/EC	The device has been used for the same applications for several years. It therefore features an appropriate electromagnetic field immunity. The device must not be used in new plants.	
Low voltage		
Directive 2006/95/EC	EN 50178:1997	
Conformity		
Insulation coordination	EN 50178	
Protection degree	IEC 60529	
Ambient conditions		
Ambient temperature	-20 ... 60 °C (-4 ... 140 °F)	
Mechanical specifications		
Protection degree	IP20	
Connection	48-pin plug connector acc. to DIN 41612 , series 2 , type F , z , b and d provided	
Mass	approx. 115 g	
Dimensions	20 x 128 x 193 mm (0.8 x 5 x 7.6 in)	
Construction type	Eurocard 100 x 160 mm (3.9 x 6.3 in) acc. to DIN 41494, front panel 4TE, mountable in 19" rack	
Coding	a1/a9	
Data for application in connection with Ex-areas		
EC-Type Examination Certificate	PTB 99 ATEX 2163 X , for additional certificates see www.pepperl-fuchs.com	
Group, category, type of protection	⊕ II (1)G [EEx ia] IIC	
Input	EEx ia IIC	
Voltage	U _o	9.6 V
Current	I _o	16 mA
Power	P _o	38 mW (linear characteristic)
Supply		
Maximum safe voltage	U _m	40 V (Attention! The rated voltage can be lower.)
Output		

Release date 2012-05-22 12:20 Date of issue 2012-05-22 037890_eng.xml

Maximum safe voltage	U_m	125 V (Attention! The rated voltage can be lower.)
Error message output		
Maximum safe voltage	U_m	125 V (Attention! The rated voltage can be lower.)
Electrical isolation		
Input/Output		safe galvanic isolation acc. to EN 50020, voltage peak value 375 V
Input/power supply		safe galvanic isolation acc. to EN 50020, voltage peak value 375 V
Directive conformity		
Directive 94/9/EC		EN 50014:1997, EN 50020:1994
General information		
Supplementary information		EC-Type Examination Certificate, Statement of Conformity, Declaration of Conformity, Attestation of Conformity and instructions have to be observed where applicable. For information see www.pepperl-fuchs.com .

Configuration

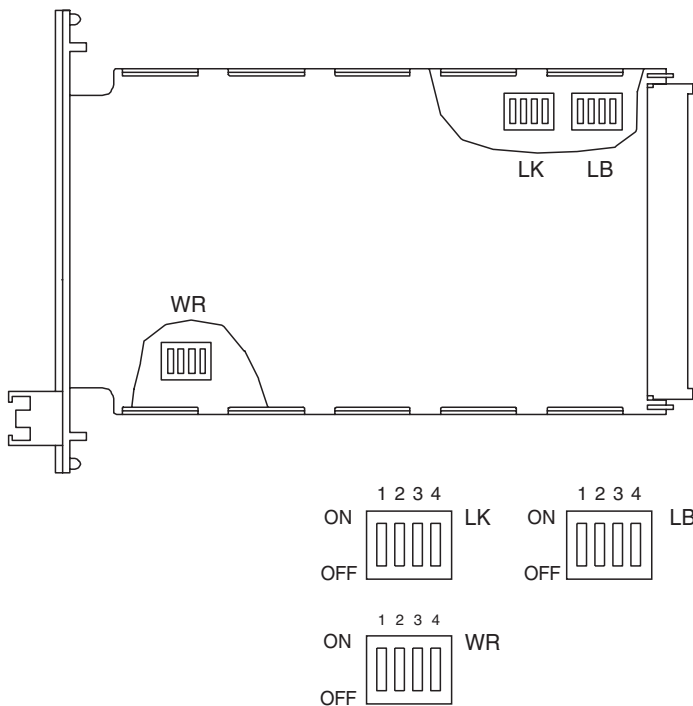

Switch position

Switch	Channel	Short circuit detection
LK1	1	ON
		OFF
LK2	2	ON
		OFF
LK3	3	ON
		OFF
LK4	4	ON
		OFF

Switch	Channel	Lead breakage detection
LB1	1	ON
		OFF
LB2	2	ON
		OFF
LB3	3	ON
		OFF
LB4	4	ON
		OFF

Switch	Channel	Reversal of mode of operation
WR1	1	ON
		OFF
WR2	2	ON
		OFF
WR3	3	ON
		OFF
WR4	4	ON
		OFF