



- 1-channel
- Input EEx ia IIC
- Device installation in Zone 2
- Lead breakage (LB) and short-circuit (SC) monitoring
- Frequency measurement, pulse-rate measurement, flow-rate measurement
- Rotation direction detection, flow direction detection
- Rotational speed monitoring
- Standstill monitoring
- Batch controller
- EMC acc. to NAMUR NE 21

**Function**

The KSD2-FI-Ex transfers frequencies of digital input signals from the hazardous area into the safe area via the Power Rail bus. Inputs for both channels can be EN 60947-5-6 (NAMUR) proximity sensors, which register the rotation speed of flow switches. Optocouplers and mechanical contacts can also be linked to the module.

Depending on its configuration, the KSD2-FI-Ex can serve as a dual channel frequency meter, signal rate meter, a flow control gauge when using rotary encoders, a rotation direction indicator, rotation speed monitor, standstill monitor or a batch controller.

The KSD2-FI-Ex has a signal input and an additional auxiliary input which is only used for rotation and flow determination. Lead monitoring checks both the leads of the signal input and the auxiliary signal input. Lead monitoring and/or mode of operation is indicated by the yellow LED IN/CHK.

Both inputs have a common reference (plus) and are galvanically isolated from output and power supply in accordance to EN 50020.

**Connection**

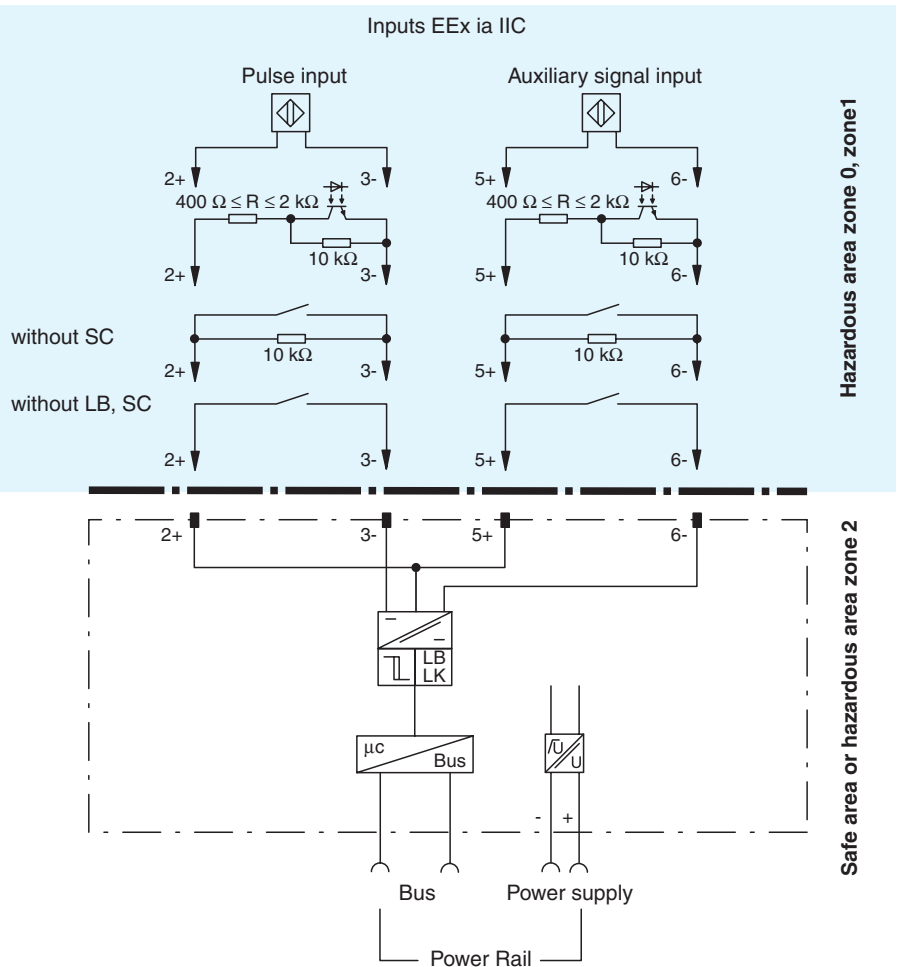

**Composition**

**Front View**

Housing type A3 (see system description)

LED yellow/red: Input check

Removable terminals blue

LED green: Power supply

LED red: Fault signal



Release date 2010-03-15 Date of issue 2010-03-15 04:00:08\_ENG.xml

<b>Supply</b>	
Connection	Power Rail
Rated voltage	20 ... 30 V DC
Ripple	< 10 %
Power consumption	1 W
<b>Input</b>	
Connection	terminals 2+, 3-; 5+, 6-
Rated values	acc. to EN 60947-5-6 (NAMUR)
Open circuit voltage/short-circuit current	approx. 8 V DC / approx. 8 mA
Switching point/switching hysteresis	1.2 ... 2.1 mA / approx. 0.2 mA
Pulse/Pause ratio	40 ... 60 % of period at 1000 Hz , 10 ... 90 % of period at 250 Hz
Line monitoring	breakage I < 0.1 mA , short-circuit I > 6 mA
<b>Output</b>	
Connection	Power Rail
Interface	CAN protocol via Power Rail bus
<b>Transfer characteristics</b>	
Deviation	< 0.1 %
Switching frequency	0.3 ... 1500 Hz If the maximum input frequency of 1500 Hz is exceeded, the signal value is undefined! No further messages.
Rotation direction detection	< 350 Hz Phase difference between pulse input signal and auxiliary pulse signal min. ± 700 µs (= ± 90 ° at 350 Hz)
<b>Electrical isolation</b>	
Input/power supply, internal bus	basic insulation acc. to EN 50178:1997, rated insulation voltage 253 V AC
<b>Directive conformity</b>	
Electromagnetic compatibility	
Directive 2004/108/EC	EN 61326-1:2006
Explosion protection	
Directive 94/9/EC	EN 60079-0:2006, EN 60079-11:2007, EN 60079-15:2005
<b>Standard conformity</b>	
Insulation coordination	EN 50178:1997
Electrical isolation	EN 60079-11:2007
Electromagnetic compatibility	NE 21:2006
Protection degree	IEC 60529
Climatic conditions	IEC 60721
<b>Ambient conditions</b>	
Ambient temperature	-20 ... 60 °C (253 ... 333 K)
Damaging gas	acc. to ISA-S71.04-1985, severity level G3
<b>Mechanical specifications</b>	
Protection degree	IP20
Connection	terminal connection ≤ 2.5 mm <sup>2</sup>
Mass	approx. 100 g
Dimensions	20 x 100 x 115 mm (0.8 x 3.9 x 4.5 in)
Mounting	DIN rail mounting
<b>Data for application in connection with Ex-areas</b>	
EC-Type Examination Certificate	ZELM 99 ATEX 0012 , for additional certificates see <a href="http://www.pepperl-fuchs.com">www.pepperl-fuchs.com</a>
Group, category, type of protection	⊕ II (1)GD [EE ia] IIC
Voltage U <sub>o</sub>	9.6 V
Current I <sub>o</sub>	16 mA
Power P <sub>o</sub>	38 mW (linear characteristic)
Statement of conformity	TÜV 00 ATEX 1617 X , observe statement of conformity
Group, category, type of protection, temperature classification	⊕ II 3G EEx nA II T4
Electrical isolation	
Input/power supply, internal bus	safe galvanic isolation acc. to EN 60079-11:2007

**Supplementary information**

EC-Type Examination Certificate, Statement of Conformity, Declaration of Conformity and instructions have to be observed. For information see [www.pepperl-fuchs.com](http://www.pepperl-fuchs.com).

Release date 2010-03-15 13:45 Date of issue 2010-03-15 048008\_ENG.xml

## Application

Frequency measurement, signal rate measurement, flow measurement with rotary encoders, rotation direction monitoring, flow direction monitoring, rotation speed monitoring, standstill monitoring or batch controller.

## Notes

### Software functions

Adjustable via the DTM in connection with the FDT frame **PACT<sub>ware</sub>**<sup>™</sup>:

- Information on devices may be saved in PC memory
- TAG numbers, 28 alphanumeric characters, can be programmed into device
- Commentary, may be saved in PC memory
- Physical units are adjustable
  - for a list see system description RPI
- Lead monitoring selectable
- Collective lead monitoring for both signal input and auxiliary signal input
- separate detection and indication of lead breakage and lead short circuit
- Malfunction output status
  - user defined
  - maintenance of the last accepted signal value
- Simulation
  - of the measurement value
  - of the device diagnosis
  - of the process channel diagnosis
- The signal value is undefined when the maximum input frequency of 1500 Hz is exceeded! In this case, no further reports are displayed.

### Frequency measurement, signal rate measurement, flow measurement, rotation speed monitoring

Only the signal input is evaluated.

- Conversion of the input frequency into various signal ranges, i. e. 0 l/s ... 20 l/s or 10 kg/min ... 500 kg/min
- 4 limit values
  - upper alarm level limit
  - upper warn level limit
  - lower warn level limit
  - lower alarm level limit

### Rotation direction monitoring, flow direction monitoring with flow control measurement, pulse rate measurement, flow control measurement, rotation direction monitoring

- Functions such as frequency measurement, however, the pulse input as well as the auxiliary signal input are evaluated. The frequency is determined by the signal input. In addition, the phase relationship of the input signal is checked at the auxiliary signal input for the determination of the rotation direction monitoring.
- The measurement signal is evaluated with the sign:
  - positive = forward, signal input is damped first, LED IN/CHK illuminates yellow
  - negative = backward, auxiliary signal input is damped first, LED IN/CHK is not illuminated

### Batch controller

Only the signal input is evaluated.

- Conversion of the input frequency into various signal ranges, i. e. 0 ... 20 l/s or 10 ... 500 kg/min
- 4 limit values
  - upper alarm level limit
  - upper warn level limit
  - lower warn level limit
  - lower alarm level limit
- 2 summary counters, resettable
- Batch Controller with pre-set warnings and pre-set alarm
- Entry of the pre-set alarm limit
- Entry of the pre-set warning limit
- Start of the counter process and deactivation of the alarm signals through the set command, as long as the shut-down values are not exceeded
- Activation of the alarm signals through stop command
- Reset of the counter process and activation of the alarm signals through the set command
- After activation of the alarm signals, input signals continue to be registered in the counter
- Entry of the shut-down values and the control commands from the control system via the external bus or via a PC using the DTM in connection with the FDT frame **PACT<sub>ware</sub>**<sup>™</sup> via the parameterization interface of the gateway.

**Batch controller with rotation direction monitoring, flow direction monitoring**

Functions as in the case of batch controller, however the signal input as well as the auxiliary signal input are evaluated.

- The direction of the input signal is indicated:
  - positive = forward, signal input is damped first, LED IN/CHK yellow, batch controller is incremented
  - negative = backward, auxiliary power input is damped first, LED IN/CHK is not illuminated, batch controller is decremented
  - negative counting is possible

**Standstill monitoring**

- In all modes of operation, such as frequency measurement, rotation direction signalling and batch controller, a standstill monitoring can be achieved by setting the 4 limit values accordingly.