



OLT150-F22-A2-V15

Diffuse mode sensor

OLT150-F22-A2-V15

CE



Laser Class II



- ◆ Energetic diffuse type sensor for detection of small objects (\varnothing 0.1 mm)
- ◆ Focal point at approx. 60 mm
- ◆ Automatic adjustment of switching points (sensitivity) via TEACH-IN
- ◆ Visible red light, pulsed LASER light
- ◆ Pre-fault indication and output (dynamic and static)
- ◆ Multifunction input
- ◆ Parameterisation via optical communication link (e.g. optional time increments)
- ◆ Connector (M12 x 1) 90° adjustable position
- ◆ Protection degree IP68
- ◆ Boost Mode - approx. 4 times the brightness of the transmitted light as an aid in adjustment

Release date: 2007-06-18 13:27 Date of issue: 2007-06-18 049482_ENG.xml

General specifications

Adjustment range	50 ... 150 mm
Upper limit of the sensing range	150 mm
Reference target	standard white 10 mm x 10 mm
Light type	Visible red light 670 nm pulsed LASER-light (12 μs), 2 mW peak power, Laser class 2, eyesafe
Diameter of the light spot	0.1 mm at a distance of 60 mm ± 2
Ambient light limit	≤ 10000 Lux sun light ≤ 7500 Lux halogen light

Indicators/operating means

LED yellow	switching state
------------	-----------------

Electrical specifications

Rated operational voltage U_e	10 ... 30 V DC , ripple 10 % _{SS} overvoltage and polarity reversal protected
No-load supply current I_0	≤ 25 mA
Time delay before availability t_v	≤ 50 ms (with time delay before availability)

Output

Output type	2 switch outputs pnp, parameterisable as - NO/NC (antivalent) - NO and pre-fault indication - NC and pre-fault indication
Rated operational current I_e	≤ 200 mA , every output, short and overload protected
Voltage drop U_d	≤ 2.5 V
Switching frequency f	≤ 1 kHz
Switch-on delay t_{on}	≤ 0.5 ms
Range hysteresis H	parameterisable with ULTRA 2001

Standard conformity

Standards	EN 60947-5-2
-----------	--------------

Ambient conditions

Ambient temperature	-10 ... 40 °C (263 ... 313 K)
Storage temperature	-40 ... 70 °C (233 ... 343 K)

Mechanical specifications

Protection degree	IP68 according to EN 60529
Connection	connector V15 (M12 x 1), 5 pin, rotatable through 90°
Material	
Housing	PBT
Optical face	scratch resistant plastic pane
Mass	60 g



OLT150-F22-A2-V15

Light spot diameter up to the rated operating distance

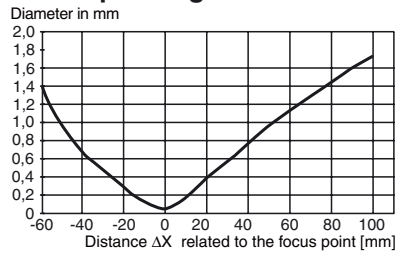

Note: The light spot is bar shaped and the measurement was achieved at the thinnest position

Dimensions

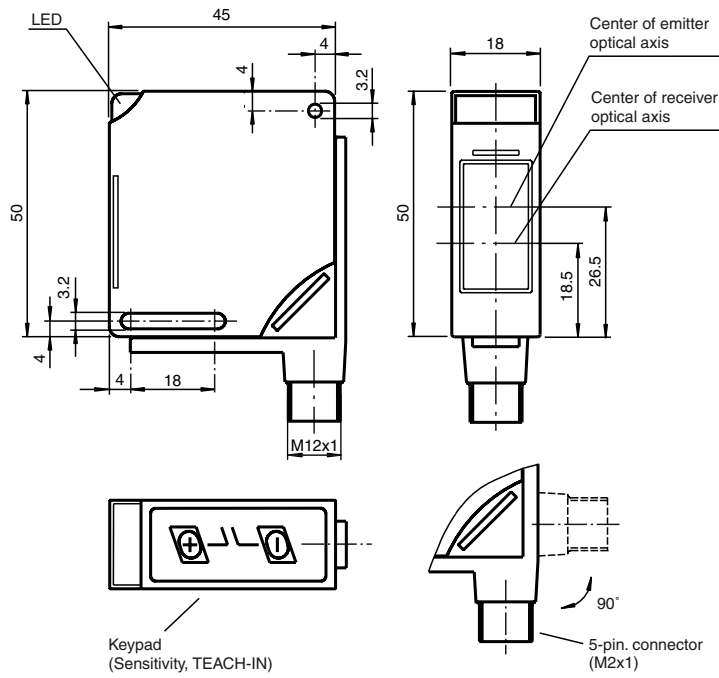

Electrical connection

A0:

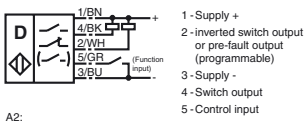

A2:

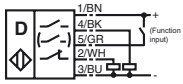

o = light ON, • = dark ON