



Mounting aid

MHW 02

- Suitable for VariKont and VariKont L sensors
- Aluminum profile, pre-mounted
- For mounting on support profiles in conveying technology (available for different types of profiles)
- Simple and fast mounting
- Sensor position adjustable in all 3 axial directions
- Sensor can be mounted length or crosswise on the profile section
- All fixing components are provided with captive screws

Modular mounting bracket

Dimensions

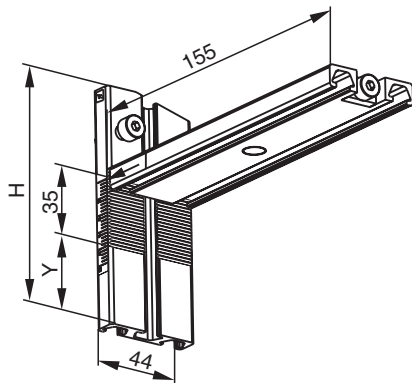

Type	H [mm]	Y [mm]
MHW 01	107	35
MHW 02	116	20
MHW 06	158	60
MHW 09	139	52
MHW 10	132	47

Technical Data

Mechanical specifications

Material	Extruded aluminum profile
Dimensions	Profile rail 1 for the installation of the mounting bracket: 155 mm Profile rail 2 for positioning the mounting bracket for the supporting profile see data table

Mounting

Installation

- Position the sliding block on the serrated side of profile rail 1 in the centre slot of profile rail 2.
- To form the mounting bracket, position the profiles at right angles to each other, by engaging the serrations.
- Stabilise the mounting bracket by tightening the cylindrical head screw on the end.
- Place the mounting bracket on the surface of the supporting profile (A) and twist the bracket by its ends (B) until it engages behind the flanges in the supporting profile.
- Align the mounting bracket.
- Secure the profile rail on the supporting profile by means of the clamping screw (C).
- Insert the two M5 x 18 screws (for VariKont Sensors) or M5 x 42 (for VariKont L Sensors) in the base of the sensor and pre-mount the sliding blocks.
- Insert the sliding blocks into the two grooves in the profile rail 1.
- Position the sensor as required and clamp it.

Note:

With some applications the installation is easier if the sensor is pre-mounted on the profile section before the mounting bracket is assembled and mounted on the supporting profile.

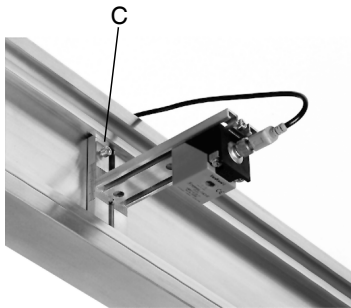

VariKont L installed on the

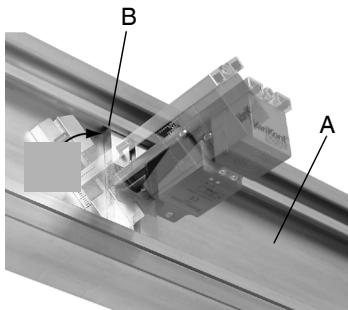

Installation of the mounting bracket on the supporting profile

Scope of Delivery

Modular mounting bracket MHW ..., consisting of

- 1 profile rail 1 (155 mm) for installation of the mounting bracket, pre-mounted with clamp, clamping plate, sliding block and cylindrical head screw (M6 x 155/DIN 912)
- 1 profile rail 2 (length H) for positioning the mounting bracket on the supporting profile, pre-mounted with sliding block and cylindrical head screw (M6 x 20 / DIN 912)
- 2 sliding blocks (M5) for the installation of the sensor
- 2 cylindrical head screws (M5 x 18/DIN 912) for VariKont Sensors
- 2 cylindrical head screws (M5 x 42/DIN 912) for VariKont L Sensors