



**Model Number**

**MLV11-8-500/47/112**

Diffuse mode sensor  
with 5-pin M12 connector, 90° adjustable position

**Features**

- Visible red light
- Automatic adjustment of switching points (sensitivity) via TEACH-IN
- Multifunction input
- Parameterization via optical communication link (e.g. optional time increments)
- Degree of protection IP68

**Dimensions**

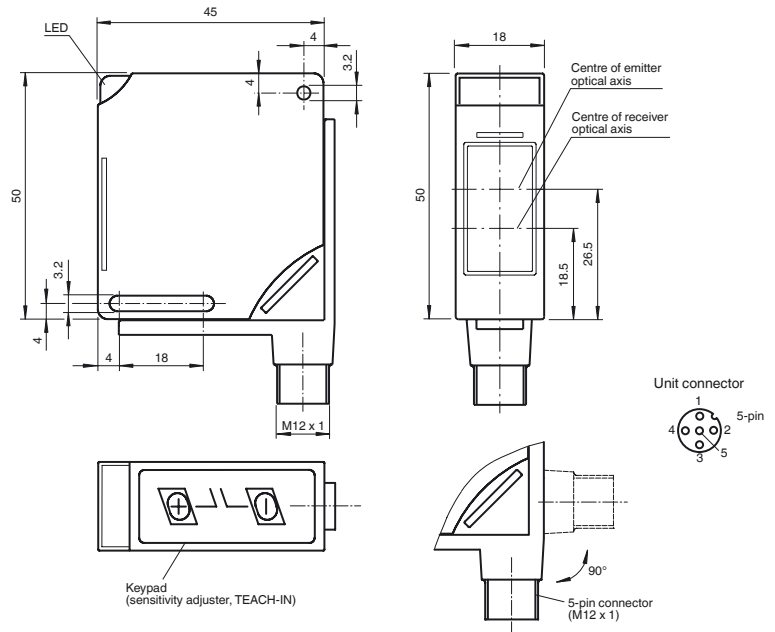

**Electrical connection**

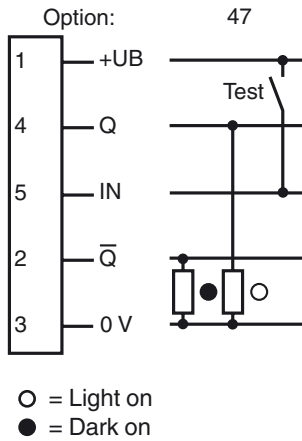

Release date: 2019-11-27 13:58 Date of issue: 2019-11-27 109128\_eng.xml

Refer to "General Notes Relating to Pepperl+Fuchs Product Information".

**Technical data****General specifications**

Detection range	0 ... 500 mm adjustable
Adjustment range	50 ... 500 mm
Reference target	standard white 100 mm x 100 mm
Light source	LED
Light type	modulated visible red light
Diameter of the light spot	25 mm at a distance of 500 mm
Ambient light limit	10000 Lux

**Indicators/operating means**

Operation indicator	LED green
Function indicator	Teach-In: LED green flashing switching state: LED yellow pre-fault indicator: LED red flashing
Control elements	membrane keys for setting sensitivity and Teach-In

**Electrical specifications**

Operating voltage	$U_B$	10 ... 30 V DC
Ripple		10 %
No-load supply current	$I_0$	≤ 25 mA
Time delay before availability	$t_v$	≤ 80 ms

**Input**

Test input	inactive: ≤ 3 V or unwired; active: ≥ 7 V
------------	---

**Output**

Pre-fault indication output	PNP, dynamic/static configurable	
Switching type	light/dark on	
Signal output	2 switch outputs PNP, programmable as - NO/NC (complementary) - NO and pre-fault indication - NC and pre-fault indication	
Switching voltage	max. 30 V DC	
Switching current	max. 200 mA	
Voltage drop	$U_d$	≤ 2.5 V
Switching frequency	$f$	≤ 1000 Hz
Response time		≤ 0.5 ms
Timer function		programmable

**Conformity**

Product standard	EN 60947-5-2
------------------	--------------

**Ambient conditions**

Ambient temperature	-25 ... 70 °C (-13 ... 158 °F)
Storage temperature	-40 ... 70 °C (-40 ... 158 °F)

**Mechanical specifications**

Housing width	18 mm
Housing height	50 mm
Housing depth	45 mm
Degree of protection	IP68
Connection	5-pin M12 x 1 connector, 90° adjustable
Material	
Housing	PBT
Optical face	scratch resistant plastic lens
Connector	AlSi
Mass	60 g

**Approvals and certificates**

CCC approval	CCC approval / marking not required for products rated ≤36 V
Approvals	CE

**Curves/Diagrams**

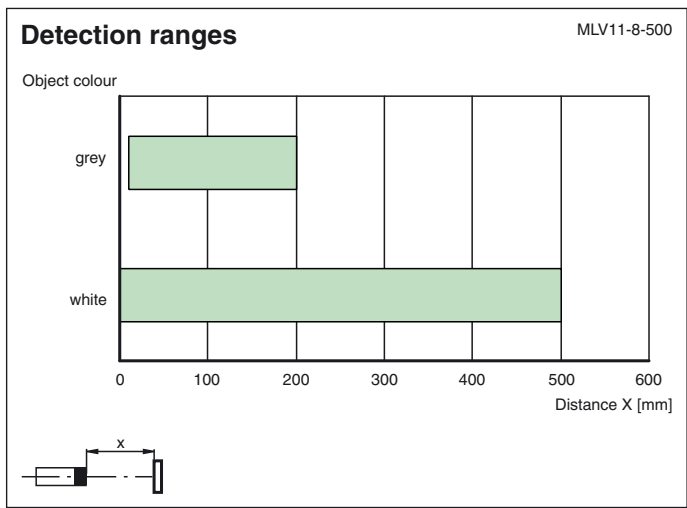
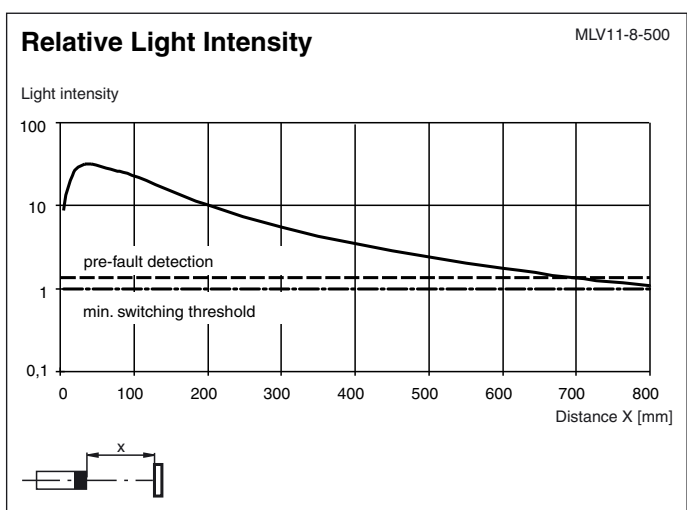
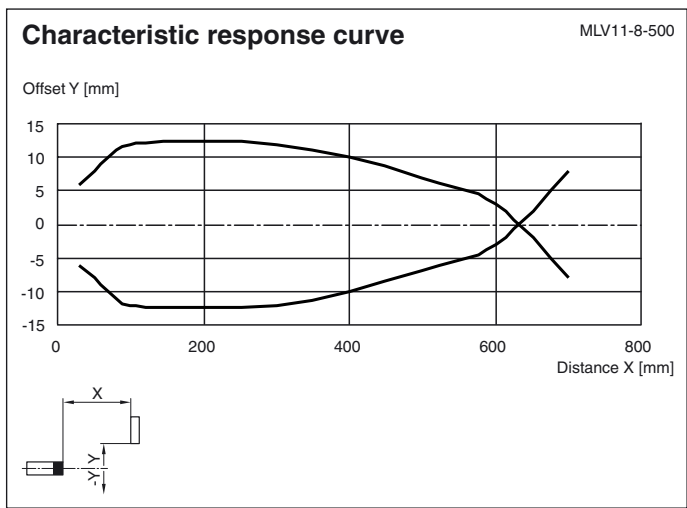

Release date: 2019-11-27 13:58 Date of issue: 2019-11-27 109128\_eng.xml

Refer to "General Notes Relating to Pepperl+Fuchs Product Information".

