



# Inductive sensor NCB50-FP-E2-P1-V1

- 50 mm flush
- 3-wire DC



## Dimensions

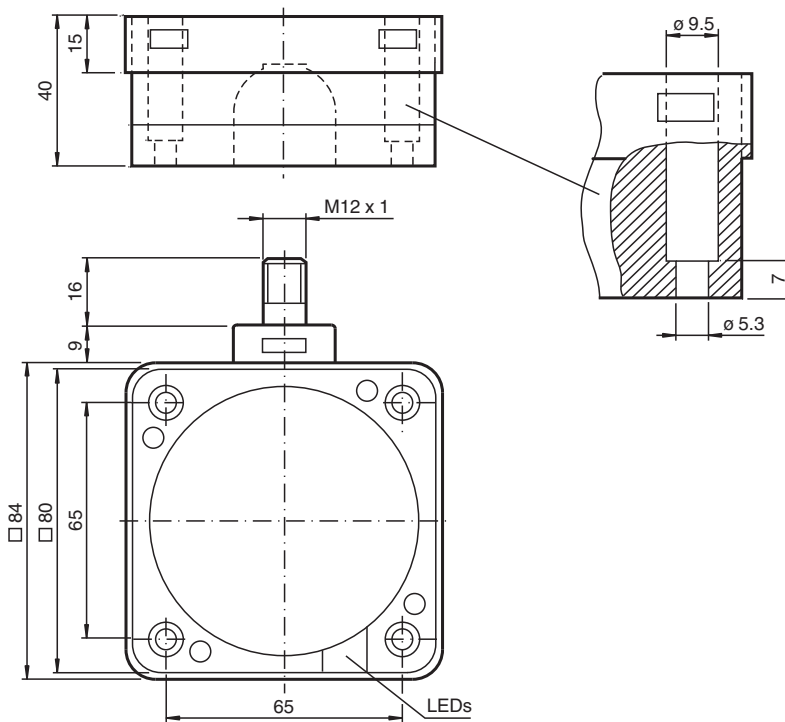

## Technical Data

### General specifications

Switching function		Normally open (NO)
Output type		PNP
Rated operating distance	$s_n$	50 mm
Installation		flush
Output polarity		DC
Assured operating distance	$s_a$	0 ... 40.5 mm
Reduction factor $r_{Al}$		0.38
Reduction factor $r_{Cu}$		0.35
Reduction factor $r_{304}$		0.83
Output type		3-wire

### Nominal ratings

Operating voltage	$U_B$	10 ... 60 V DC
Switching frequency	$f$	0 ... 80 Hz
Hysteresis	$H$	typ. 3 %

Release date: 2020-12-10 Date of issue: 2020-12-10 Filename: 125750\_eng.pdf

Refer to "General Notes Relating to Pepperl+Fuchs Product Information".

Pepperl+Fuchs Group  
www.pepperl-fuchs.com

USA: +1 330 486 0001  
fa-info@us.pepperl-fuchs.com

Germany: +49 621 776 1111  
fa-info@de.pepperl-fuchs.com

Singapore: +65 6779 9091  
fa-info@sg.pepperl-fuchs.com

**PF** PEPPERL+FUCHS

## Technical Data

Reverse polarity protection		reverse polarity protected
Short-circuit protection		pulsing
Voltage drop	$U_d$	$\leq 3 \text{ V}$
Operating current	$I_L$	0 ... 200 mA
Off-state current	$I_r$	0 ... 0.5 mA
No-load supply current	$I_0$	$\leq 20 \text{ mA}$
Time delay before availability	$t_v$	$\leq 300 \text{ ms}$
Operating voltage indicator		LED, green
Switching state indicator		LED, yellow
<b>Functional safety related parameters</b>		
MTTF <sub>d</sub>		940 a
Mission Time (T <sub>M</sub> )		20 a
Diagnostic Coverage (DC)		0 %
<b>Compliance with standards and directives</b>		
Standard conformity		
Standards		EN 60947-5-2:2007 IEC 60947-5-2:2007
<b>Approvals and certificates</b>		
EAC conformity		TR CU 020/2011
UL approval		cULus Listed, General Purpose
CSA approval		cCSAus Listed, General Purpose
CCC approval		Certified by China Compulsory Certification (CCC)
<b>Ambient conditions</b>		
Ambient temperature		-25 ... 70 °C (-13 ... 158 °F)
<b>Mechanical specifications</b>		
Connection type		Connector plug M12 x 1 , 4-pin
Housing material		PBT
Sensing face		PBT
Housing base		PBT
Degree of protection		IP68

## Connection

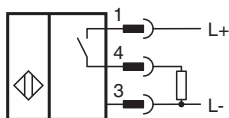

## Connection Assignment

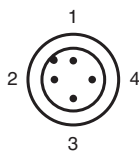

Wire colors in accordance with EN 60947-5-2

1	BN	(brown)
2	WH	(white)
3	BU	(blue)
4	BK	(black)

## Mounting

These sensors are especially designed for embeddable mounting in conveyor floors. Due to its precise location in metal base plates the sensor is afforded a high degree of mechanical protection. No clearance is required between the sensor and the base plate, avoiding the need for protective guarding to prevent possible foot injury.

The large sensing range ensures positive detection, and thus provides consistent control and monitoring of the conveyor.

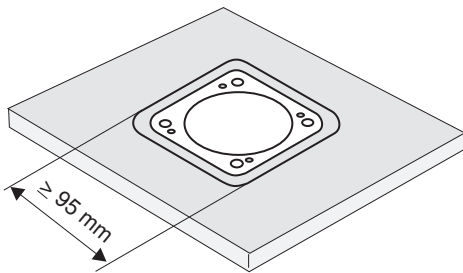

**Warning!**  
Once the metal screening has been removed, the sensor can no longer be embeddable mounted.

## Accessories

	<b>V1-W-2M-PUR</b>	Female cordset single-ended M12 angled A-coded, 4-pin, PUR cable grey
	<b>V1-G-2M-PUR</b>	Female cordset single-ended M12 straight A-coded, 4-pin, PUR cable grey

Release date: 2020-12-10 Date of issue: 2020-12-10 Filename: 125750\_eng.pdf

Refer to "General Notes Relating to Pepperl+Fuchs Product Information".

Pepperl+Fuchs Group  
www.pepperl-fuchs.com

USA: +1 330 486 0001  
fa-info@us.pepperl-fuchs.com

Germany: +49 621 776 1111  
fa-info@de.pepperl-fuchs.com

Singapore: +65 6779 9091  
fa-info@sg.pepperl-fuchs.com