

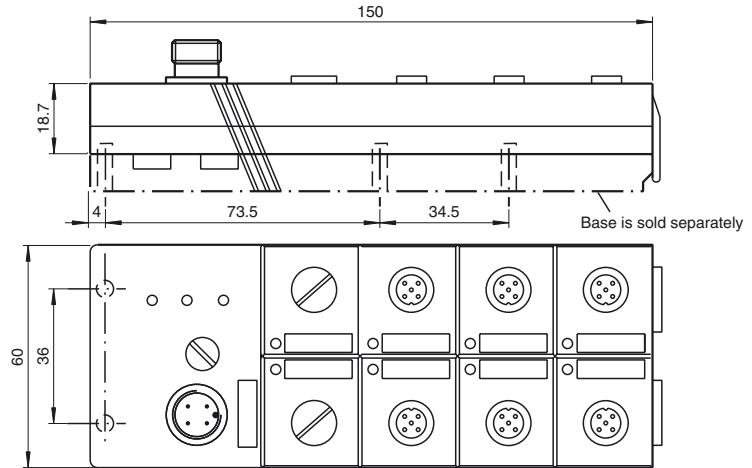

Dimensions

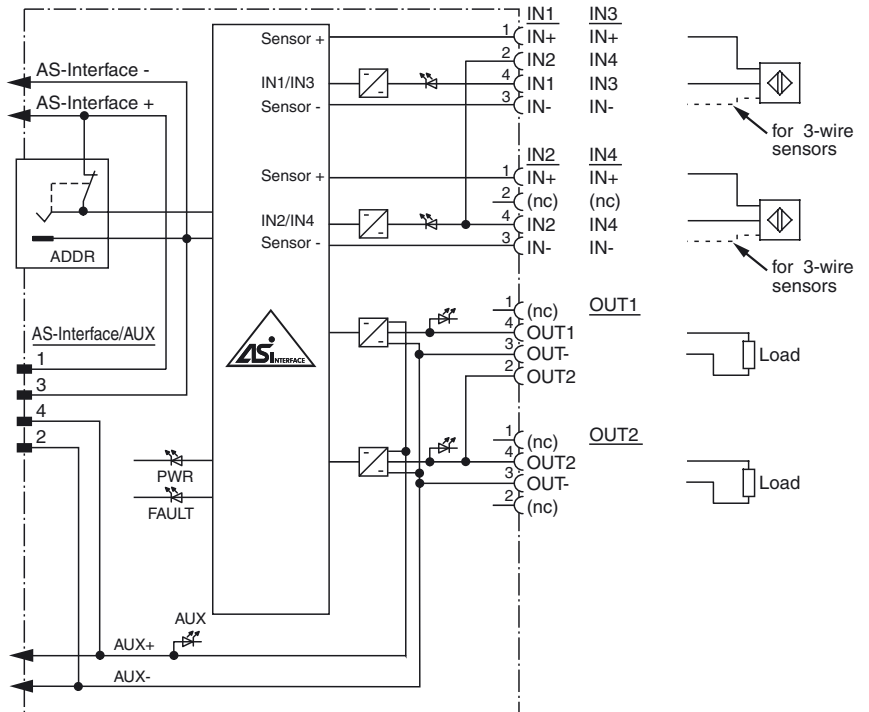

Electrical connection



Indicating / Operating means

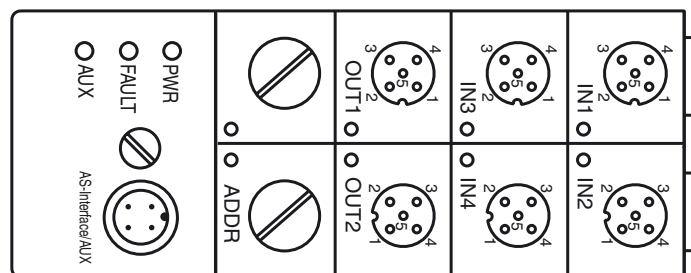

Model number

VBA-4E2A-G2-ZA/EA2-Ex

G2 flat module  
4 inputs (PNP) and 2 electronic outputs

Features

- Category, ignition protection class  
 ⓧ II 3G nA  
 ⓧ II 3D tD
- A/B slave with extended addressing possibility for up to 62 slaves
- Addressing jack
- Flat cable connection with cable piercing technique, variable flat cable guide or M12 round connector for AS-Interface and external auxiliary power
- Communication monitoring
- Inputs for 2-, 3-, and 4-wire sensors
- Power supply of outputs from the external auxiliary voltage
- Supply for inputs from AS-Interface
- Function display for bus, ext. auxiliary voltage, inputs and outputs
- Detection of overload on sensor supply
- Detection of output overload

Release date: 2019-01-09 10:22 Date of issue: 2019-01-09 130756\_eng.xml

**Technical data****General specifications**

Slave type	A/B slave
AS-Interface specification	V3.0
Required master specification	≥ V2.1
Group, category, type of protection	 II 3G EEx nA II T4 X  II 3D Ex tD A22 IP67 T85°C X

**Indicators/operating means**

LED FAULT	error display; LED red red: communication error or address is 0 red flashing: overload of sensor power supply or outputs
LED PWR	AS-Interface voltage; LED green
LED AUX	ext. auxiliary voltage $U_{AUX}$ ; LED green
LED IN	switching state (input); 4 LED yellow
LED OUT	Switching state (output); 2 LED yellow

**Electrical specifications**

Auxiliary voltage (output)	$U_{AUX}$	20 ... 30 V DC PELV
Rated operating voltage	$U_e$	26.5 ... 31.6 V PELV from AS-Interface
Rated operating current	$I_e$	≤ 40 mA (without sensors) / max. 240 mA
Protection class		III
Surge protection		$U_{AUX}, U_{in}$ : Over voltage category III, safe isolated power supplies (PELV)

**Input**

Number/Type	4 inputs for 2- or 3-wire sensors (PNP), DC option 2 inputs for 4-wire sensors (PNP), DC
Supply	from AS-Interface
Voltage	21 ... 26 V
Current loading capacity	≤ 200 mA ( $T_B \leq 40^\circ\text{C}$ ), ≤ 150 mA ( $T_B \leq 60^\circ\text{C}$ ), overload-proof and short-circuit protected
Input current	≤ 8 mA (limited internally)
Switching point	according to DIN EN 61131-2 (Type 2)
0 (unattenuated)	≤ 2 mA
1 (attenuated)	≥ 4 mA

**Output**

Number/Type	2 electronic outputs, PNP, overload and short-circuit proof
Supply	from external auxiliary voltage $U_{AUX}$
Current	1 A per output, 2 A total
Voltage	≥ ( $U_{AUX} - 0.5\text{ V}$ )

**Programming instructions**

Profile	S-7.A.2
IO code	7
ID code	A
ID1 code	7
ID2 code	2

Data bits (function via AS-Interface)	input	output
D0	IN1	OUT1
D1	IN2	OUT2
D2	IN3	-
D3	IN4	-

**Parameter bits (programmable via AS-i) function**

P0	not used
P1	not used
P2	not used
P3	not used

**Ambient conditions**

Ambient temperature	-25 ... 60 °C (-13 ... 140 °F)
Storage temperature	-25 ... 70 °C (-13 ... 158 °F)

**Mechanical specifications**

Degree of protection	IP67 according to EN 60529
Connection	AS-Interface/ $U_{AUX}$ : Cable piercing method yellow flat cable/black flat cable or M12 round connector Inputs/outputs: M12 round connector
Material	
Housing	PBT
Cable	
Length	L max. 30 m (Inputs)
Mass	150 g

**General information**

Use in the hazardous area	see instruction manuals
Category	3G; 3D

**Compliance with standards and directives**

Directive conformity	observe notices on the certificate of conformity.
EMC Directive 2004/108/EC	EN 50295:1999-10, EN 61326:2002-03

**Function**

The VBA-4E2A-G2-ZA/EA2-Ex is an AS-Interface coupling module with 4 inputs and 2 outputs, which is suitable for use in explosion hazardous areas (zone 2 and 22). The applying conditions can be found in the following operating instructions.

2 and 3-wire sensors, 4-wire sensors as well as mechanical contacts (e.g. push buttons) can be connected. The outputs are electronic outputs, which may be loaded with 24 V DC and 1 A per output.

The IP67 flat module is ideal for applications in the field. An addressing jack is integrated in the module.

The connections to the sensors/actuators are established via M12 x 1 screw connections. For displaying the current switching state, an LED is available for each channel on the module's top side. An LED for monitoring the AS-Interface communication and for displaying that the module has the address 0 is also available. One LED shows the voltage of the AS-Interface and another the external voltage supply.

By default, the mounting plate U-G2FF is used for connection to the AS-Interface flat cable and the external 24 V DC voltage supply. This base enables the user to connect flat cables from both sides. Alternatively, AS-Interface and external voltage supply can be connected via a M12 x 1 connector on the module's top side. In this case, the base U-G2 must be used.

The device is equipped with communication monitoring, which switches off power to the outputs if no communication has taken place on the AS-Interface line for longer than 40 ms.

An overloading of the internal input supply or of the outputs is signalled to the AS-Interface master via the "Peripheral fault" function. Communication via the AS-Interface remains intact.

**Note:**

The mounting plate to the module must be ordered separately.

**Accessories****VBP-HH1-V3.0-KIT**

AS-Interface Handheld with accessory

**VAZ-V1-B3**

Blind plug for M12 sockets

**V1-CLIP**

Unlocking protector for M12 connector

**VBP-HH1-V3.0**

AS-Interface Handheld

**VAZ-PK-1,5M-V1-G**

Adapter cable module/hand-held programming device

**VAZ-FK-ED-G2**

AS-Interface end seal for G2 modules

**VAZ-FK-ST1**

AS-Interface-flat cable sleeve, heat-shrinkable tube

**VAZ-2T1-FK-1M-PUR-V1-W**

Splitter box AS-Interface and auxiliary voltage to 1 x M12 round connector

**VAZ-2T1-FK-2M-PUR-V1-W**

Splitter box AS-Interface and auxiliary voltage to 1 x M12 round connector

**VAZ-V1S-B**

Blind plug for M12 sockets

**Matching system components****U-G2**

AS-Interface module mounting base

**U-G2FF**

AS-Interface module mounting base for connection to flat cable (AS-Interface and external auxiliary power)

ATEX Directive 94/9/EC

EN 60079-15:2003, IEC / EN 60947-5-2:2004

Standard conformity

AS-Interface

EN 50295:1999, IEC 62026-2:2006

**Notes**

For 4-wire sensors, it is only possible to use plug-in slot IN1 or IN3 for inputs 1+2 or 3+4 (jumped internally).

**Equipment protection level Gc (nA)**

Instruction	<b>Manual electrical apparatus for hazardous areas</b>
<b>Device category 3G (nA)</b>	for use in hazardous areas with gas, vapour and mist
CE marking	<b>CE</b>
ATEX marking	<b>Ex</b> II 3G EEx nA II T4 X
Directive conformity	94/9/EG
Standards	EN 60079-15:2003 Ignition protection category "nA"
General	The apparatus has to be operated according to the appropriate data in the data sheet and in this instruction manual. The data stated in the data sheet are restricted by this operating instruction! The special conditions must be observed!
Installation, commissioning	Laws and/or regulations and standards governing the use or intended usage goal must be observed.
Maintenance	No modifications must be undertaken on apparatus, which is operated in hazardous areas. Repairs to such apparatus are not permissible.
<b>Special conditions</b>	
Maximum permissible ambient temperature $T_{Umax}$	Dependent on the sensor supply, the on-load current is as stated in the data sheet.
Protection from mechanical danger	The apparatus must be protected from mechanical damage.
Protection from UV light	The apparatus must be protected from damaging UV radiation.

**Equipment protection level Dc**

Device category 3D	for use in hazardous areas with non-conducting combustible dust
CE marking	<b>CE</b>
ATEX marking	<b>Ex</b> II 3D Ex tD A22 IP67 T85°C X
Directive conformity	94/9/EG
Standards	EN 61241-1:2004 Protection via housing "tD"
<b>General</b>	The apparatus has to be operated according to the appropriate data in the data sheet and in this instruction manual. The data stated in the data sheet are restricted by this operating instruction! The special conditions must be observed!
Installation, commissioning	Laws and/or regulations and standards governing the use or intended usage goal must be observed.
Maintenance	No modifications must be undertaken on apparatus, which is operated in hazardous areas. Repairs to such apparatus are not permissible.
<b>Special conditions</b>	
Protection from mechanical danger	The apparatus must be protected from mechanical damage.
Plug connector	Plug connectors must not be removed or plugged in under stress. Deposits of dust must be removed before unplugging a connector. When the plug connectors are disconnected, care must be taken to ensure that dirt does not get into the internal area (d. h. normally sealed by the connected plug connector). For the socket a VAZ-V1-B dummy plug must be used for this purpose (Pepperl+Fuchs mounting accessory). A VAZ-VIS-B cap (Pepperl+Fuchs mounting accessory) must be used to protect the plug. The tightening torque value for the plugs and caps is 0.4 Nm ... 0.5 Nm. Connectors should be tightened thoroughly by hand. In order to prevent unintentional loosening of the plug connector, the connector must be secured with the V1 Clip (Pepperl+Fuchs mounting accessory). The cables are to be laid in such a way that no tension is exerted on the connector.

Do not connect inputs and outputs, which are supplied via the module from AS-interface or via auxiliary power, with power supply and signal circuits with external potentials.