

Universal Fieldbus Power Hub, Motherboard, Common Interface

MB-FB-4

- 4 segments, individual modules per segment
- Supports all PLC and PCS hosts
- High-power trunk: Live work on devices in any hazardous area
- Features for best signal quality, low heat dissipation
- For FOUNDATION Fieldbus H1 and PROFIBUS PA
- Optional advanced diagnostics
- Passive impedance and CREST technology for high reliability
- Supports Ex ic/nL voltage limitation
- Installation in Zone 2/Div. 2



Function

The FieldConnex® Universal Power Hub is a modular fieldbus power supply, providing the most options for most reliable communication. It supports explosion protection e.g. the High-Power Trunk for longest cable run and highest device count. The Power Hub supports optional Advanced Diagnostics for fast fieldbus commissioning and online monitoring. The motherboard is the wiring interface and mounting plate with common screw terminals for all DCS and PLC host systems. Sockets for all modules enable simple installation and replacement without tools. Certain motherboards enable power redundancy with seamless transfer. Pairs of modules feed each segment. Availability and a long service life are achieved through: only one passive impedance filter per segment with CREST for superior signal transmission, optimized design for low power dissipation and high-availability fieldbus termination. Any mounting direction allows optimized and space-saving cabinet layout.

Connection

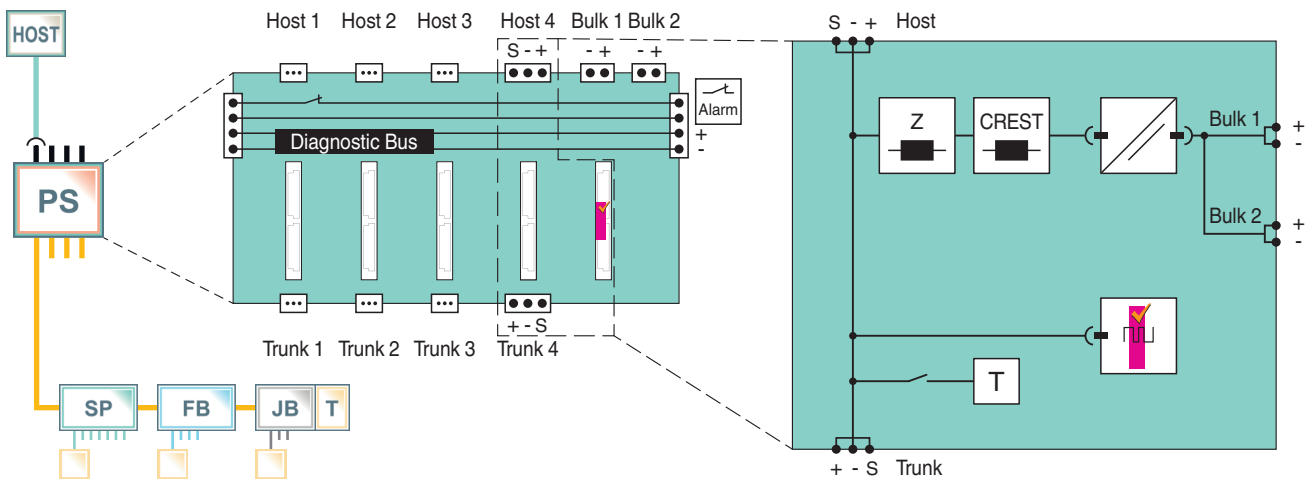

Technical Data

Supply

Connection	redundant		
Rated voltage	U_r	19.2 ... 35 V SELV/PELV	
Rated current	I_r	16 A	

Fieldbus connection

Number of segments			
Simplex	4		
Host-side	general purpose host		

Release date: 2022-07-04 Date of issue: 2022-07-04 Filename: 130998_eng.pdf

Refer to "General Notes Relating to Pepperl+Fuchs Product Information".

Pepperl+Fuchs Group
www.pepperl-fuchs.com

USA: +1 330 486 0002
pa-info@us.pepperl-fuchs.com

Germany: +49 621 776 2222
pa-info@de.pepperl-fuchs.com

Singapore: +65 6779 9091
pa-info@sg.pepperl-fuchs.com

PEPPERL+FUCHS

Technical Data

Terminating resistor		selectable 100 Ω
Indicators/operating means		
Fault signal		VFC alarm output via connectors
Galvanic isolation		
Fieldbus segment/Fieldbus segment		functional insulation acc. to DIN EN 50178, rated insulation voltage 50 V _{eff}
Fieldbus segment/Supply		functional insulation acc. to DIN EN 50178, rated insulation voltage 50 V _{eff}
Directive conformity		
Electromagnetic compatibility		
Directive 2014/30/EU		EN 61326-1:2013
Standard conformity		
Electromagnetic compatibility		
		NE 21:2011
Degree of protection		IEC 60529
Fieldbus standard		IEC 61158-2
Shock resistance		EN 60068-2-27
Vibration resistance		EN 60068-2-6
Corrosion resistance		acc. to ISA-S71.04-1985, severity level G3
Ambient conditions		
Ambient temperature		-40 ... 60 °C (-40 ... 140 °F)
Storage temperature		-40 ... 85 °C (-40 ... 185 °F)
Relative humidity		< 95 % non-condensing
Shock resistance		15 g , 11 ms
Vibration resistance		1 g , 10 ... 150 Hz
Pollution degree		max. 2, according to IEC 60664
Corrosion resistance		acc. to ISA-S71.04-1985, severity level G3
Mechanical specifications		
Connection type		screw terminals
Core cross section		2.5 mm ²
Housing material		Polycarbonate
Housing width		125 mm
Housing height		220 mm
Housing depth		65 mm
Degree of protection		IP20
Mass		approx. 850 g
Mounting		DIN mounting rail
Coating		conformal coated
Data for application in connection with hazardous areas		
Certificate		TÜV 04 ATEX 2500 X
Marking		Ⓔ II 3 G Ex nA IIC T4 Gc
Directive conformity		
Directive 2014/34/EU		EN 60079-0:2012 , EN 60079-11:2012 , EN 60079-15:2010
International approvals		
FM approval		CoC 3024816, CoC 3024816C
Approved for		Class I, Division 2, Groups A, B, C, D, T4 / Class I, Zone 2, AEx/Ex nA IIC T4
IECEX approval		IECEX TUN 13.0038X
Approved for		Ex nA IIC T4 Gc
General information		
Supplementary information		Statement of Conformity, Declaration of Conformity, Attestation of Conformity and instructions have to be observed where applicable. For information see www.pepperl-fuchs.com .

Release date: 2022-07-04 Date of issue: 2022-07-04 Filename: 130998_eng.pdf

Refer to "General Notes Relating to Pepperl+Fuchs Product Information".

Pepperl+Fuchs Group
www.pepperl-fuchs.comUSA: +1 330 486 0002
pa-info@us.pepperl-fuchs.comGermany: +49 621 776 2222
pa-info@de.pepperl-fuchs.comSingapore: +65 6779 9091
pa-info@sg.pepperl-fuchs.com

PEPPERL+FUCHS

Assembly

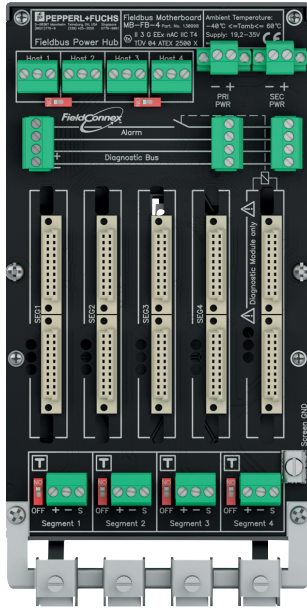

Release date: 2022-07-04 Date of issue: 2022-07-04 Filename: 130998_eng.pdf

Refer to "General Notes Relating to Pepperl+Fuchs Product Information".

Pepperl+Fuchs Group
www.pepperl-fuchs.com

USA: +1 330 486 0002
pa-info@us.pepperl-fuchs.com

Germany: +49 621 776 2222
pa-info@de.pepperl-fuchs.com

Singapore: +65 6779 9091
pa-info@sg.pepperl-fuchs.com

 **PEPPERL+FUCHS**

Additional Information

Dimensions

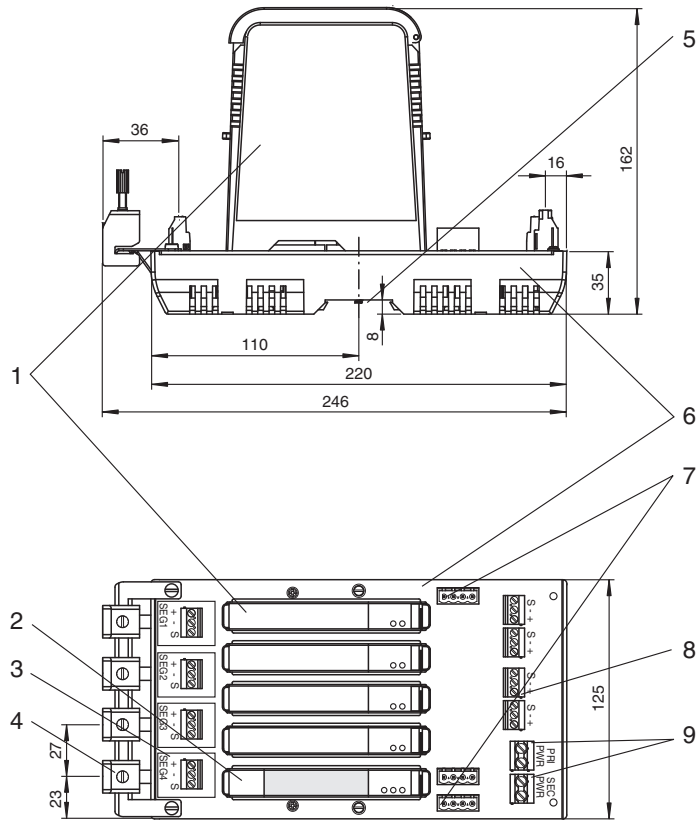

Description:

- 1 Power Supply Modules, see separate data sheets
- 2 Diagnostic Module, see separate data sheet
- 3 Connections for fieldbus trunk, terminator switch
- 4 Screening/earthing kit for trunk cables shield, optional accessory
- 5 Mounting slot for DIN rail
- 6 Motherboard MB-FB-4
- 7 Connections for alarm voltage free contact and diagnostics bus
Diagnostics link cable, optional accessory
- 8 Connections for host
- 9 Connections for redundant bulk power supply

Compatible power modules

	HD2-FBPS-1.17.500		HD2-FBPS-1.23.500		HD2-FBPS-1.25.360		HD2-FBPS-1.500		HD2-FBCL-1.500	
Power Output										
Voltage (V)	15 ... 17	21 ... 23	25 ... 28	28 ... 30	- ¹					
Current (mA)	500	500	360	500	500					
Limit U ₀ (V)	17.5	24	-	-	-					
Device in ...	Type of Protection									Required Installation Components
Zone 0/Div. 1	Intrinsically safe Ex ia									FieldBarrier
Zone 1/Div. 1	Intrinsically safe Ex ia									FieldBarrier
Zone 1/Div. 1	Flameproof Ex d									Segment Protector R-SP-E12 or any Segment Protector installed in Zone 2
Zone 2	Intrinsically safe Ex ic (FISCO)									Selected Segment Protectors

Release date: 2022-07-04 Date of issue: 2022-07-04 Filename: 130998_eng.pdf

Refer to "General Notes Relating to Pepperl+Fuchs Product Information".

Zone 2	Intrinsically safe Ex ic (Entity)		■				Selected Segment Protectors
Div. 2	Non-incendive	■	■	■	■		Any Segment Protector; power module selection depends on voltage of field device
Safe Area	No specific type of protection			■	■	■	Segment Protector recommended

[†] follows bulk power supply

Diagnostic module selection

The following diagnostic modules are compatible with this motherboard.

Type code	Description
HD2-DM-B	Diagnostic Module, basic version
HD2-DM-A	Diagnostic Module, advanced version
HD2-DM-A.RO	Diagnostic Module, advanced version, relay output

The stationary and mobile Advanced Diagnostic Module (ADM) and related components provide measurement tools for the fieldbus physical layer. The ADM monitors many quality indicating values of the fieldbus physical layer. An expert system, which is included, analyzes the values and issues easy to understand messages indicating cause and remedy. The ADM is recommended for:

- **Faster commissioning and plant start-up:** Installation issues are known and corrected before loop check commences
- **Reliable operation through online monitoring:** The quality of the physical layer and installation is monitored making fieldbus a manageable asset
- **Efficient troubleshooting:** An expert system guides the user through issues and faults in the fieldbus installation

Many other tools are included that enhance fieldbus installation and upkeep. Please see datasheet on HD2-DM-A.

Additional Information

Accessories

Type code	Description
ACC-MB-HSK	Screening/earthing kit
ACC-MB-HDC	Diagnostic link cable, length 6 cm
ACC-MB-CC	Set of two connector covers for Ex ic hazardous area applications

Installation note

see manual