

Features

- 1-channel
- 24 V DC supply voltage
- Lead breakage (LB) and short-circuit (SC) monitoring
- Transfer of HART signals
- Power Rail bus
- EMC acc. to NAMUR NE 21

Function

Der KSD2-CO-S transmits a 0/4 mA ... 20 mA current signal. Loads between 30 Ω ... 750 Ω can be connected. The output is galvanically isolated from the bus and power supply.

The output field circuit is monitored for lead breakage and short circuit conditions. The device allows for monitoring and programming of positioners, which support the HART protocol.

The KSD2-CO-S is delivered standard with the KF-STP-GN device connectors. The 2.3 mm jacks are integrated in this connector for use with HART communicators. The KFD2-HMM-16 or KFD0-HMS-16 HART multiplexers can be connected to terminals 11+ and 10-.

Application

The control of solenoid drivers and positioners. The interface allows a bidirectional communication between the position controller and a handheld terminal or a HART multiplexer. The bus transfers the digital control signal exclusively.

Assembly

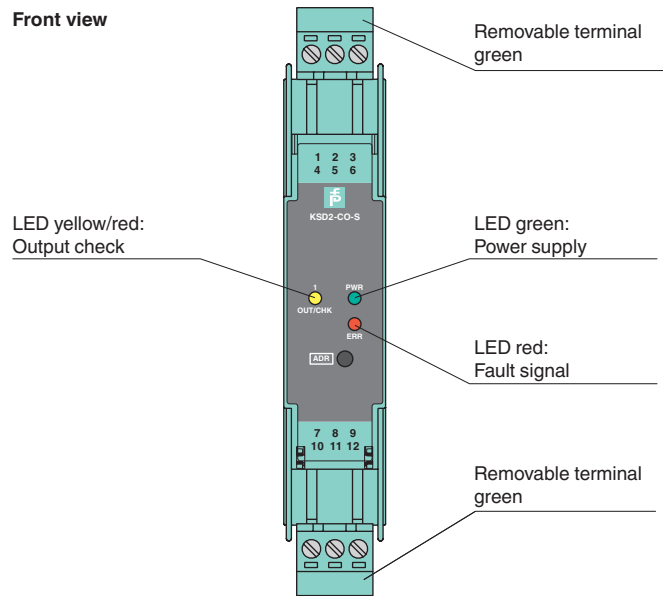

Connection

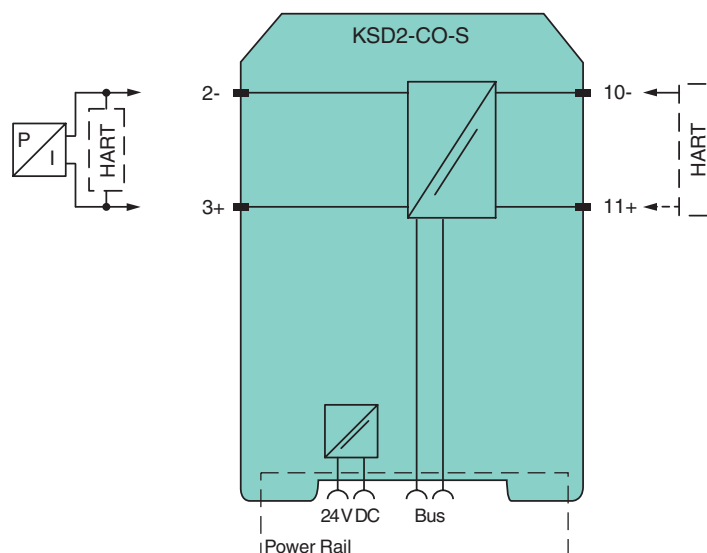

Release date 2010-06-17 16:10 Date of issue 2010-06-17 207618_ENG.xml

Supply	
Connection	Power Rail
Rated voltage	20 ... 30 V DC
Ripple	< 10 %
Power loss	1.3 W
Power consumption	1.3 W
Input	
Connection	Power Rail
Interface	CAN protocol via Power Rail bus
Output	
Connection	terminals 2, 3
Current	0/4 ... 20 mA
Load	30 ... 750 Ω
Residual ripple	≤ 0.25 %
Line fault detection	line breakage possible for $I_{\text{nominal}} \geq 0.2 \text{ mA}$, line breakage at $I < 0,1 \text{ mA}$ short circuit possible for $I_{\text{nominal}} \geq 1.0 \text{ mA}$, short circuit at load < 30 Ohms
Transfer characteristics	
Deviation	0.1 % of output signal range at 20 °C (293 K)
Influence of ambient temperature	0.01 % / K of output signal range
Electrical isolation	
Output/power supply, internal bus	safe electrical isolation acc. to IEC/EN 60079-11, voltage peak value 375 V
Directive conformity	
Electromagnetic compatibility	
Directive 2004/108/EC	EN 61326-1:2006
Conformity	
Insulation coordination	IEC 62103
Electromagnetic compatibility	NE 21:2006
Protection degree	IEC 60529
Ambient conditions	
Ambient temperature	-20 ... 60 °C (-4 ... 140 °F)
Damaging gas	acc. to ISA-S71.04-1985, severity level G3
Mechanical specifications	
Protection degree	IP20
Connection	terminal connection ≤ 2.5 mm ²
Mass	approx. 120 g
Dimensions	20 x 107 x 115 mm (0.8 x 4.2 x 4.5 in)
Mounting	DIN rail mounting
Data for application in connection with Ex-areas	
Declaration of conformity	Pepperl+Fuchs
Group, category, type of protection, temperature classification	⊕ II 3 G Ex nA II T4
Directive conformity	
Directive 94/9/EC	EN 60079-0:2006, EN 60079-15:2005
General information	
Supplementary information	EC-Type Examination Certificate, Statement of Conformity, Declaration of Conformity, Attestation of Conformity and instructions have to be observed where applicable. For information see www.pepperl-fuchs.com .

Release date 2010-06-17 16:10 Date of issue 2010-06-17 207618_ENG.xml

Notes

Software functions

Adjustable by the **PACT_{ware}**TM human machine interface:

- TAG numbers, 28 alphanumeric characters, can be programmed into device
- Commentary, may be saved in PC memory Information on devices may be saved in PC memory
- Physical units are adjustable
 - list see system description RPI
- Lead monitoring selectable
- Separate detection and indication of lead breakage and lead short circuit
- Lower scale value and upper scale value of the measurement range
 - for the determination of the overflow and underflow range
 - for the configuration of the analogue monitor of the human machine interface
- Overrange and underrange alarm
- Malfunction output status
 - user defined
 - min.
 - max.
 - hold last value
- Simulation
 - of the input value
 - of the device diagnosis
 - of the process channel diagnosis