

Incremental rotary encoder

RVS58S-YYYKYA6ZT-01024



- Safe rotary encoder, thanks to integrated functional safety
- Usable up to SIL 3 acc. to IEC 61508
- TÜV certified
- Suitable as motor feedback system for safe drives in accordance with IEC 61800-5-2
- Incremental encoder with sin/cos interface
- 1024 or 2048 signal periods
- Thermally stabilized with the highest precision for high resolution interpolation



Function

The RVS58S – a combination of precision and integrated safety technology for demanding requirements.

The RVS58S rotary encoder is suitable for use in safety-aligned systems up to

- SIL3 in accordance with IEC 61508
- Performance Level e in accordance with IEC 13849
- Category 4 in accordance with DIN EN 954-1

given the corresponding prerequisites with regard to the diagnostic capability of the higher-level control/evaluation system.

Typical applications for this rotary encoder are found in safety-evaluated drive technology (Motor feedback). Thanks to the 1 V_{SS} sine/cosine interface the RVS58S is compatible with the current drive converters available on the market, as are required for the fine positioning of drives and servo-drive systems in industrial applications.

A clear increase in precision and the smooth running of the drive at an attractive price, including certificated safety in accordance with the applicable standards, enable this rotary encoder to be used in a wide variety of applications.

Dimensions

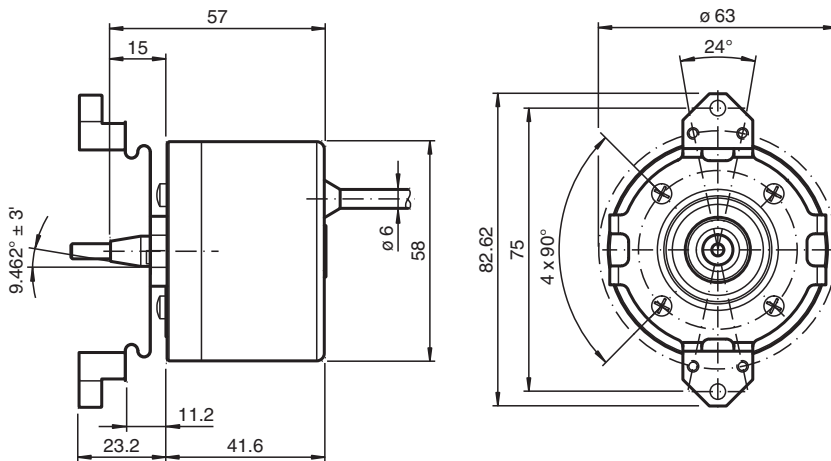

Technical Data

General specifications	
Pulse count	1024 and 2048
Functional safety related parameters	
Safety Integrity Level (SIL)	SIL 3
Performance level (PL)	PL e
MTTF _d	1000 a
Mission Time (T _M)	20 a
PFH _d	2.41 E-9 1/h

Release date: 2022-12-12 Date of issue: 2022-12-12 Filename: 215089_eng.pdf

Refer to "General Notes Relating to Pepperl+Fuchs Product Information".

Pepperl+Fuchs Group
www.pepperl-fuchs.com

USA: +1 330 486 0001
fa-info@us.pepperl-fuchs.com

Germany: +49 621 776 1111
fa-info@de.pepperl-fuchs.com

Singapore: +65 6779 9091
fa-info@sg.pepperl-fuchs.com

PEPPERL+FUCHS

Technical Data

L ₁₀		7.5 E+9 at 6000 rpm
Diagnostic Coverage (DC)		98 %
Electrical specifications		
Operating voltage	U _B	5 V DC ± 5 %
No-load supply current	I ₀	max. 70 mA
Output		
Output type		sine / cosine
Amplitude		1 V _{ss} ± 10 %
Load current		max. per channel 10 mA , short-circuit protected, reverse polarity protected
Output frequency		max. 200 kHz (3 dB limit)
Connection		
Cable		Single stranded wires with crimp contact, 10 x AWG26, 230 mm
Standard conformity		
Degree of protection		DIN EN 60529, IP40
Climatic testing		DIN EN 60068-2-78 , no moisture condensation
Emitted interference		EN 61000-6-4:2007/A1:2011
Noise immunity		DIN EN 61000-6-2 , advanced testing level to IEC 61326-3-1 EN 61326-3-1:2008
Shock resistance		DIN EN 60068-2-27, 100 g, 3 ms
Vibration resistance		DIN EN 60068-2-6, 20 g, 55 ... 2000 Hz
Functional safety		IEC 61508:2010 (SIL3) EN 62061:2005/A2:2015 EN/ISO 13849-1:2015 IEC 61800-5-2:2016 Suitable up to SIL 3, PL e depending from configuration, see instruction leaflet
Approvals and certificates		
UL approval		cULus Recognized, General Purpose, Class 2 Power Source
TÜV approval		Cert. no. Z10 068273 0003
Ambient conditions		
Operating temperature		-20 ... 115 °C (-4 ... 239 °F) , fixed cable
Storage temperature		-40 ... 100 °C (-40 ... 212 °F)
Mechanical specifications		
Material		
Housing		aluminum, blank
Flange		3.1655 aluminum
Shaft		Stainless steel 1.4305 / AISI 303
Mass		approx. 350 g
Rotational speed		max. 8000 min ⁻¹
Moment of inertia		≤ 25 gcm ²
Starting torque		≤ 1.5 Ncm
Shaft load		
Axial		40 N at max. 6000 rpm 10 N at max. 8000 rpm
Radial		at 60 N max. 6000 rpm at 20 N max. 8000 rpm

Release date: 2022-12-12 Date of issue: 2022-12-12 Filename: 215089_eng.pdf

Connection

Signal	Individual leads Ø0.45 mm
GND	White
GND _{sense}	Black
U _b	Brown
U _{b sense}	Violet
A / cos	Green
B / sin	Grey
\bar{A} / $\bar{\cos}$	Yellow
\bar{B} / $\bar{\sin}$	Orange
0	Blue
$\bar{0}$	Red
Screen	-

Operation

Signal outputs

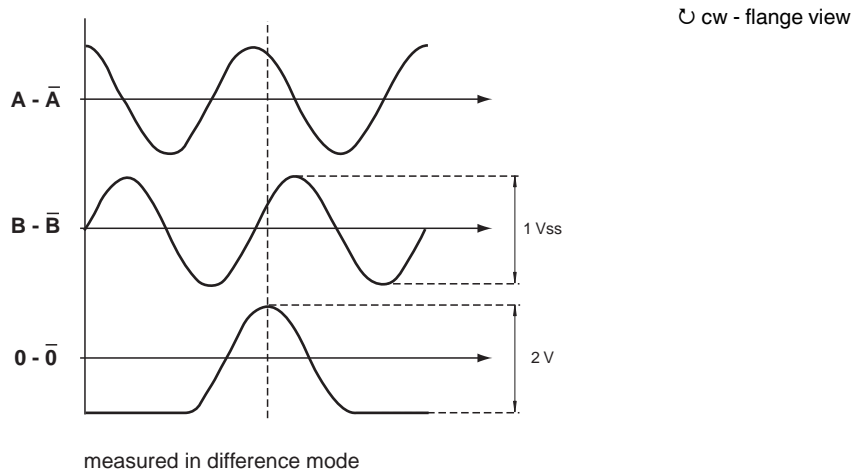

Type Code

Order code

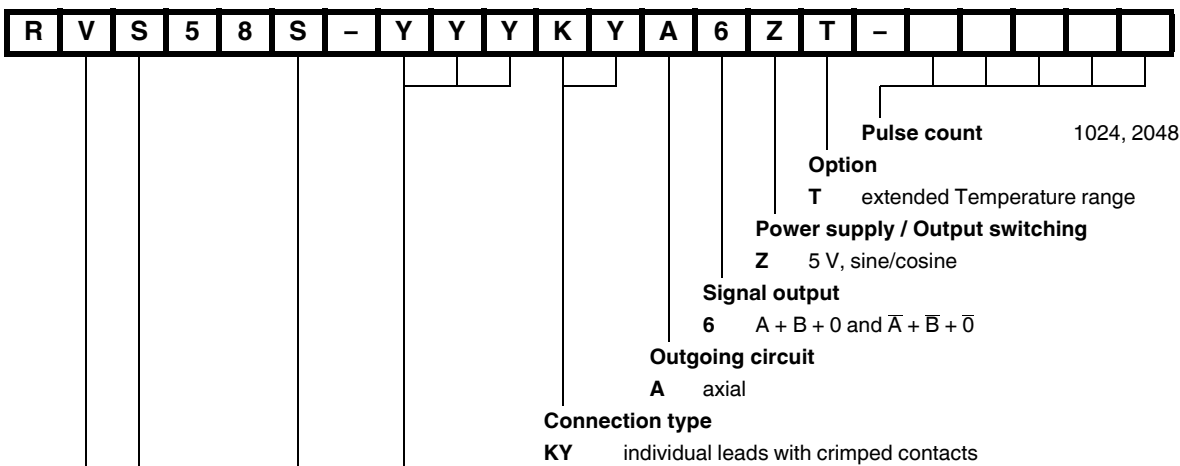

Release date: 2022-12-12 Date of issue: 2022-12-12 Filename: 215089_eng.pdf

Order code

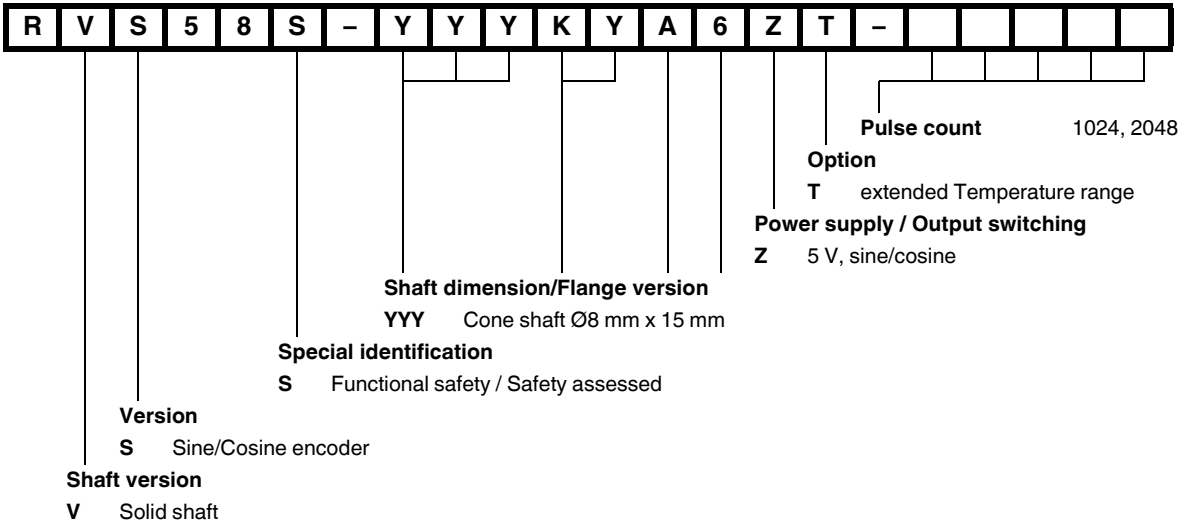

Safety Information

Anti-interference measures

The use of highly sophisticated microelectronics requires a consistently implemented anti-interference and wiring concept. This becomes all the more important the more compact the constructions are and the higher the demands are on the performance of modern machines.

The following installation instructions and proposals apply for "normal industrial environments". There is no ideal solution for all interfering environments.

When the following measures are applied, the encoder should be in perfect working order:

- Termination of the serial line with a 120 Ω resistor (between Receive/Transmit and Receive/Transmit) at the beginning and end of the serial line (e. g. the control and the last encoder).
- The wiring of the encoder should be laid at a large distance to energy lines which could cause interferences.
- Cable cross-section at least 0,14 mm².
- The wiring of 0 V should be arranged radially, if and when possible.
- Do not kink or jam the cables.
- Adhere to the minimum bending radius as given in the data sheet and avoid tensile as well as shearing load.

Operating instructions

Every encoder manufactured by Pepperl+Fuchs leaves the factory in a perfect condition. In order to ensure this quality as well as a faultless operation, the following specifications have to be taken into consideration:

- Avoid any impact on the housing and in particular on the encoder shaft as well as the axial and radial overload of the encoder shaft.
- The accuracy and service life of the encoder is guaranteed only, if a suitable coupling is used.
- The operating voltage for the encoder and the follow-up device (e. g. control) has to be switched on and off simultaneously.
- Any wiring work has to be carried out with the system in a dead condition.
- The maximum operating voltages must not be exceeded. The devices have to be operated at extra-low safety voltage.

Safety instructions



Please observe the national safety and accident prevention regulations as well as the subsequent safety instructions in these operating instructions when working on encoders.
 If failures cannot be remedied, the device has to be shut down and has to be secured against accidental operation.
 Repairs may be carried out only by the manufacturer. Entry into and modifications of the device are not permissible.



Tighten the clamping ring only, if a shaft has been fitted in the area of the clamping ring (hollow shaft encoders).
 Tighten all screws and plug connectors prior to operating the encoder.



Do not stand on the encoder!

Release date: 2022-12-12 Date of issue: 2022-12-12 Filename: 215089_eng.pdf

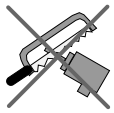

Do not remachine the drive shaft!

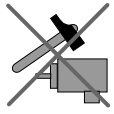

Avoid impact!



Do not remachine the housing!