



## Radar sensor RMS-G-RC-HS



- Industrial gate opener with the ability to differentiate between people and vehicles
- Extra-wide detection area and long detection range
- Easily programmable
- Direction detection
- Version HS for vehicle detection up to 60 km/h
- Programmable by remote control

Premium industrial door opener for detecting vehicles up to 60 km/h, can be operated remotely, detection range 7 m x 6 m, max. installation height 7 m, black housing, 2 relay contact outputs, cable connection



### Function

The microprocessor-controlled microwave motion sensors based on the latest 24 GHz technology provide a high degree of reliability even in difficult operating conditions and can be used with all automatic (industrial) doors up to a height of 7 m. The RMS-G sensors are equipped with intelligent functions, such as vehicle detection, to enable them to be used in a wide variety of applications. The special industrial door microwave sensor can be configured so that the industrial door only opens when a vehicle approaches it, while passing pedestrians are ignored. The sensor differentiates between people and vehicles.

### Application

- Opening impulse sensor for industrial doors
- Motion sensor for people and objects
- Activation sensors for detecting vehicles traveling at a maximum of 60 km/h (RMS-G-RC-HS)

**Dimensions**

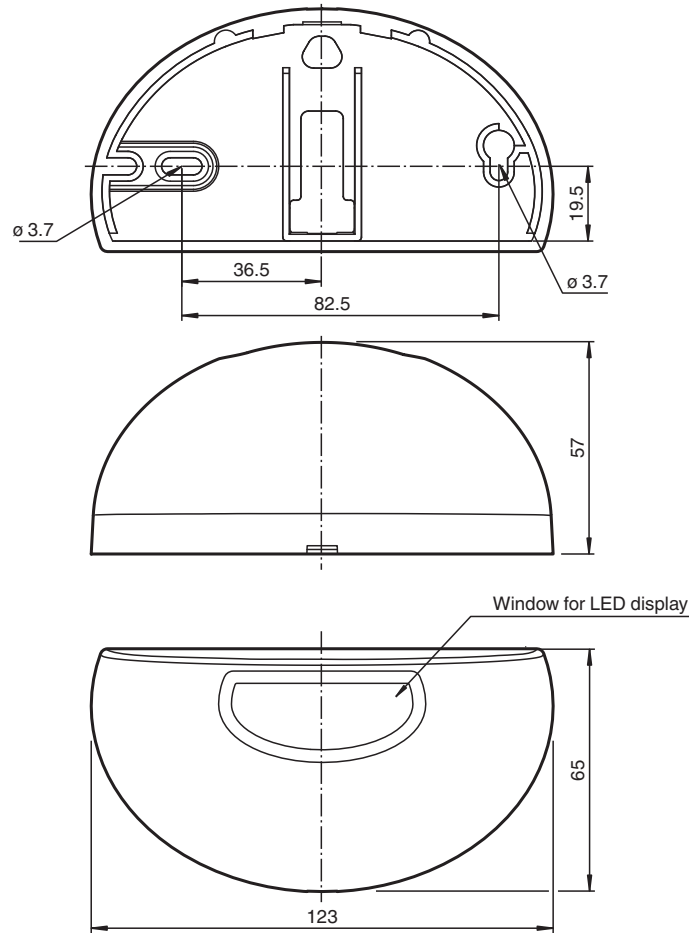

**Technical Data**

**General specifications**

Sensing range	7000 x 6000 mm (DxW) at 5000 mm mounting height and 30° tilt angle 8000 x 5000 mm (DxW) at 7000 mm mounting height and 30° tilt angle
Function principle	Microwave module
Detection speed	min. 0.1 m/s , max. ... 16.7 m/s (60 km/h)
Setting angle	0 ... 40 ° in 5 ° increments
Operating frequency	24.05 ... 24.25 GHz K-Band
Operating mode	Radar motion sensor
Transmitter radiated power (EIRP)	< 20 dBm

**Indicators/operating means**

Function indicator	LED red/green
Control elements	Programming push-button for selection of operating modes : Direction detection , Cross traffic suppression , Vehicle detection , Switching type , relay hold up time
Control elements	Programming via 2 keys , alternative via remote control (Accessories ordered separately)

**Electrical specifications**

Operating voltage	$U_B$	12 ... 36 V DC , 12 ... 28 V AC
No-load supply current	$I_0$	$\leq 50$ mA at 24 V DC
Protection class		III, when operating on safety low power
Power consumption	$P_0$	$\leq 1$ W

**Output**

Switching type		NO/NC
Signal output		2 relay outputs

Release date: 2021-07-20 Date of issue: 2021-07-20 Filename: 220713\_eng.pdf

**Technical Data**

Switching voltage		max. 48 V AC / 48 V DC
Switching current		max. 0.5 A AC / 1 A DC
Switching power		max. 24 W / 60 VA
De-energized delay	t <sub>off</sub>	0.2 ... 5 s adjustable
<b>Directive conformity</b>		
Radio and telecommunication terminal equipment		
Directive 2014/53/EU		yes This device can be used in all countries within the European Union. Use in North America is not permitted. In other countries, all applicable national regulations must be observed.
<b>Approvals and certificates</b>		
CE conformity		2014/53/EU This device can be used in all countries within the European Union. In other countries, all applicable national regulations must be observed.
FCC approval		No - Use in North America is not permitted.
<b>Ambient conditions</b>		
Operating temperature		-20 ... 60 °C (-4 ... 140 °F)
Storage temperature		-30 ... 70 °C (-22 ... 158 °F)
Relative humidity		max. 90 % non-condensing
<b>Mechanical specifications</b>		
Mounting height		max. 7000 mm
Degree of protection		IP54
Connection		plug-in screw terminals 4-pin and 2-pin , 8 m connecting cable included with delivery
Material		
Housing		ABS, anthracite
Mass		120 g
Dimensions		123 mm x 65 mm x 57 mm
<b>Suitable series</b>		
Series		RMS

**Connection Assignment**

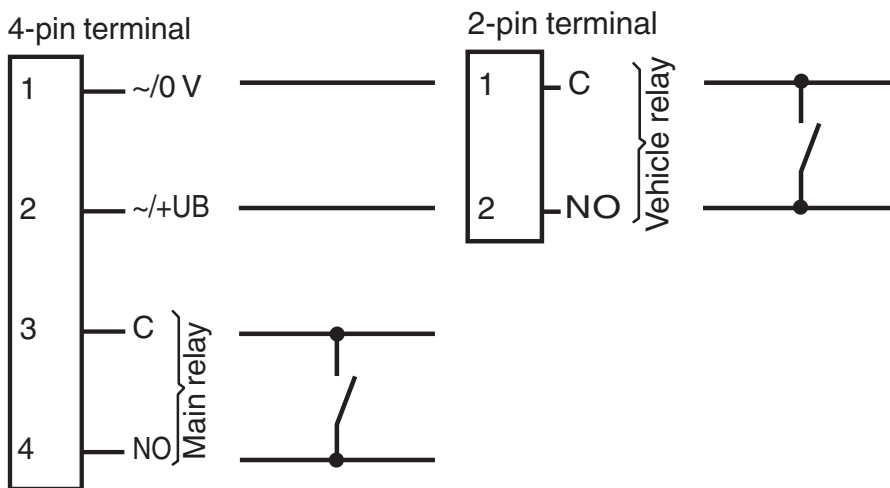

Release date: 2021-07-20 Date of issue: 2021-07-20 Filename: 220713\_eng.pdf

**Assembly**

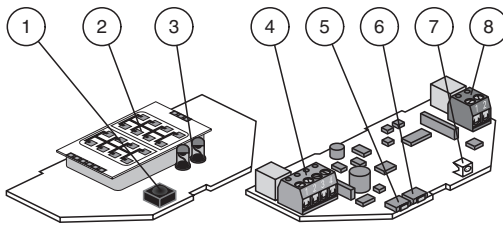

1	IR receiver
2	Antenna
3	IR-transmitter
4	Terminals (power supply/main relay)
5	Pushbutton / Menu
6	Pushbutton / Value
7	LED (red/green)
8	Terminals (vehicle relay)

**Application**

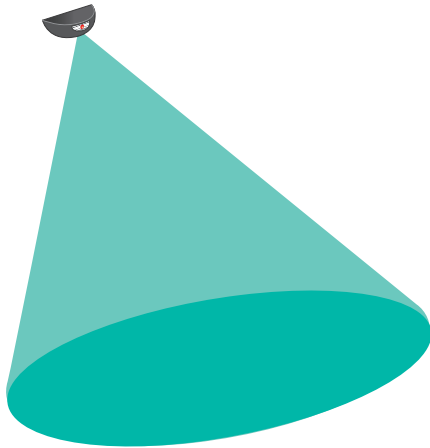

**Function Principle**



Radar sensors are microwave sensors that adopt the principle of Doppler radar. The most important requirement for radar detection is that the object to be detected is moving. The radar sensors emit microwaves of a defined frequency to detect people and large objects moving within the specified velocity range of the radar sensor.

The microwaves emitted by the emitter are reflected back from the ground or other surfaces to the receiver. If there is no motion in the monitored zone, the emitted and reflected frequencies are identical. Nothing is detected. If people, animals or objects are moving in the monitored zone, the reflected frequency changes and therefore triggers a detection.

Based on the latest 24 GHz technology with integrated microprocessor control, these sensors provide a high level of reliability, even in difficult operational conditions. The 24 GHz frequency, known as 'K-band,' is reserved by CETECOM for this application area all round the world.

The RMS-G series of sensors are equipped with intelligent functions to enable them to be used in a wide variety of applications. The cross-traffic suppression system can be configured so that the door only opens when vehicles or people approach it, while passing pedestrians are ignored. With direction detection, the opening impulse can be triggered based on the direction of motion. Depending on the setting, only movements towards or away from the sensor are detected.

**Accessories**

	<b>RMS Weather Cap</b>	All-weather hood for RMS series microwave sensors, for ceiling and wall installation
	<b>RMS Remote Control</b>	Infrared remote control for RMS series and RAVE
	<b>RMS/RaDec Ceiling Kit wh</b>	Ceiling mount kit for radar sensors in the RMS and RaDec Series

Release date: 2021-07-20 Date of issue: 2021-07-20 Filename: 220713\_eng.pdf

Refer to "General Notes Relating to Pepperl+Fuchs Product Information".

t

## Settings

The sensor RMS-G-RC-HS is adjusted in programming mode directly on the device via two keys: --> 8 = key/menu; 7 = key/value. The flash sequence of the LED indicates the respective settings.

By means of the RMS remote control, which is available as an accessory, the sensor can be easily and quickly programmed from the ground in an optimum manner. The bidirectional infrared remote control with LDC display and self-explanatory menu navigation has a range of 10 m. Thus, also sensors with high mounting heights can be precisely and conveniently adjusted.

Order code: **RMS Remote control**

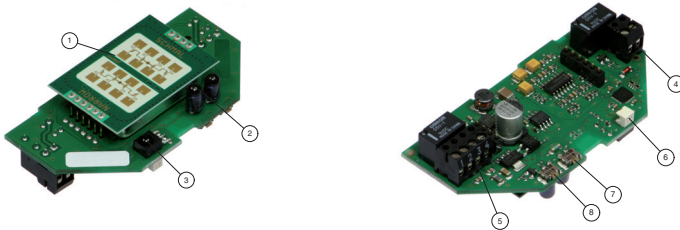

- 1. Antenna
- 2. IR emitter diodes
- 3. IR receiver diodes
- 4. Screw terminal (vehicle relay)
- 5. Screw terminal (voltage/main relay)
- 6. Display LED
- 7. Key/value
- 8. Key/menu

The following properties can be adjusted:

### 1. Dimensions of the detection field

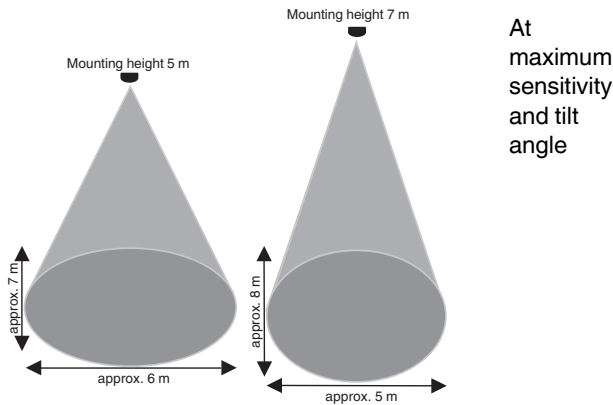

### 2. Dimensions of the detection field

By adjusting the sensitivity by means of the keys or remote control, the size of the detection field can be changed.

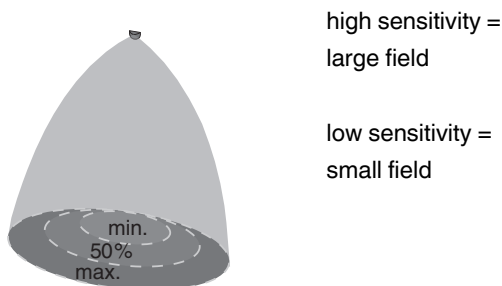

### 3. Position of the detection field

Release date: 2021-07-20 Date of issue: 2021-07-20 Filename: 220713\_eng.pdf

The detection field can be rotated in 5 steps from 0° to 40°. The printed circuit board may also be installed at an angle.

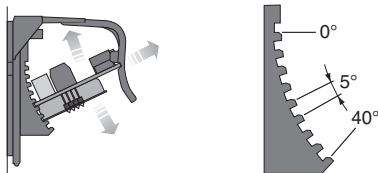

**4. Detection without direction detection**

forward / backward

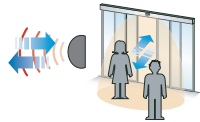

**5. Detection with direction detection**

- a) forward (towards the radar)
- b) backward (away from the radar)

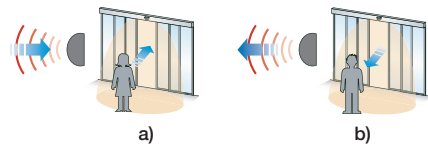

**6. Suppression of crossing traffic**

- a) door opens
- b) door remains closed

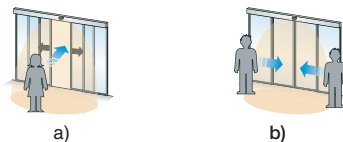

**7. Person, vehicle detection**

The sensor evaluates the movements of persons or vehicles in a different way and, depending on the setting, it switches the main relay or both relays simultaneously.

The differentiated person/vehicle detection makes it possible to open gates for vehicles only. Approaching persons must use the side entrance.

**8. Relay functions**

The main relay always switches, i.e. when detecting objects and vehicles.

The vehicle relay only switches when vehicle detection is switched on and when a vehicle is detected.

**Function indicator**

Release date: 2021-07-20 Date of issue: 2021-07-20 Filename: 220713\_eng.pdf

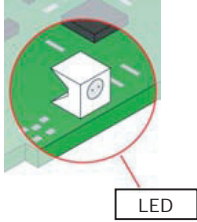

<b>LED green</b>	Device ready to operate
<b>LED red</b>	Main relay switched
<b>LED green/red flashing quickly</b>	Vehicle relay switched
<b>LED green/red flashing slowly</b>	Initialisation (for approx. 10 secs. after switch-on)
<b>LED green flashing</b>	Command received
<b>LED red flashing</b>	Error