

Features

- 1-channel signal conditioner
- 24 V DC supply (Power Rail)
- Input 2-wire and 3-wire SMART transmitters and 2-wire SMART current sources
- 0/4 mA ... 20 mA current sink output
- Terminals with test points
- Up to SIL2 acc. to IEC 61508

Function

This signal conditioner provides the isolation for non-intrinsically safe applications.

The device supplies 2-wire and 3-wire SMART transmitters, and can also be used with 2-wire SMART current sources.

It transfers the analog input signal as an isolated current value.

Digital signals may be superimposed on the input or output signal and are transferred bi-directionally.

It is designed to provide a sink mode output.

If the HART communication resistance in the loop is too low, the internal resistance of 250 Ω between terminals 8 and 9 can be used.

Test sockets for the connection of HART communicators are integrated into the terminals of the device.

Application

The device supports the following SMART protocols:

- HART
- BRAIN
- Foxboro

Assembly

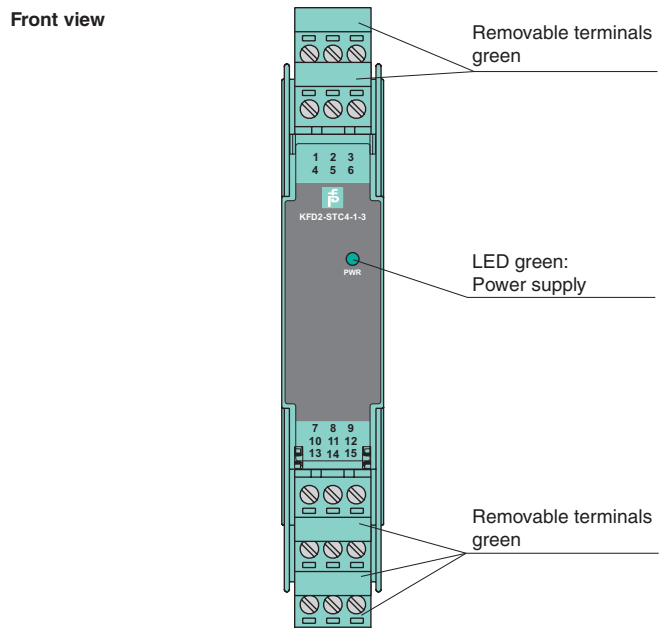

SIL2

Connection

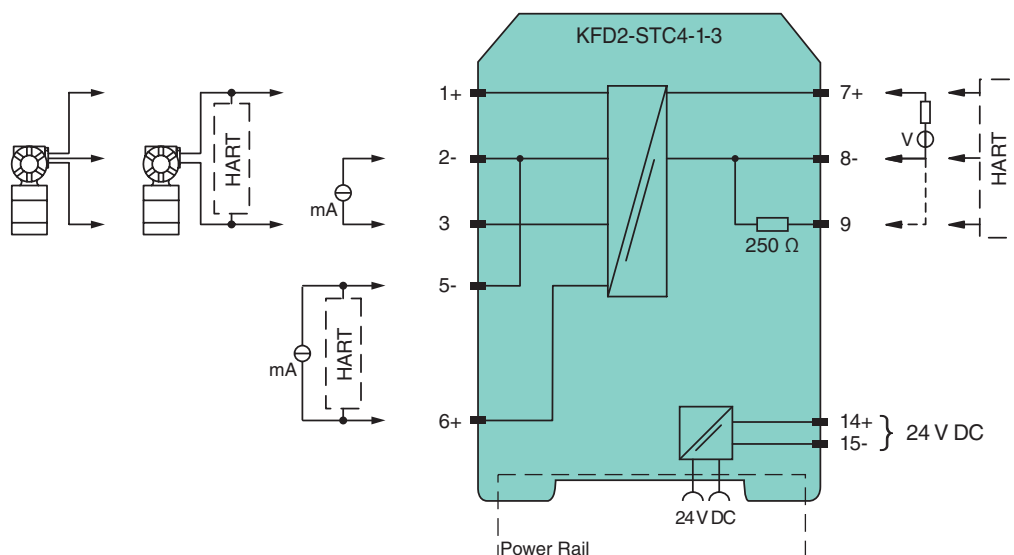

Release date 2010-11-04 14:04 Date of issue 2010-11-04 223217_ENG.xml

General specifications	
Signal type	Analog input
Supply	
Connection	Power Rail or terminals 14+, 15-
Rated voltage	20 ... 35 V DC
Ripple	within the supply tolerance
Power loss	1.6 W
Power consumption	2.5 W
Input	
Connection	terminals 1+, 2-, 3 or 5-, 6+
Input signal	0/4 ... 20 mA
Voltage drop U_d	≤ 2.4 V at 20 mA (terminals 5, 6)
Input resistance	$\leq 64 \Omega$ terminals 2-, 3 ; $\leq 500 \Omega$ terminals 1+, 3 (250 Ω load)
Available voltage	≥ 16 V at 20 mA terminals 1+, 3
Output	
Connection	terminals 7+, 8-; 10+, 11-
Output signal	0/4 ... 20 mA (overload > 25 mA)
Ripple	$\leq 50 \mu A_{rms}$
External supply (loop)	11 ... 30 V DC
Transfer characteristics	
Deviation	at 20 °C (68 °F), 0/4 ... 20 mA $\leq 10 \mu A$ incl. calibration, linearity, hysteresis, loads and fluctuations of supply voltage
Influence of ambient temperature	0.25 $\mu A/K$
Frequency range	input to output: bandwidth with 0.5 V_{pp} signal 0 ... 7.5 kHz (-3 dB) output to input: bandwidth with 0.5 V_{pp} signal 0.3 ... 7.5 kHz (-3 dB)
Rise time	20 μs
Start-up time	200 μs
Electrical isolation	
Output/power supply	functional insulation, rated insulation voltage 50 V AC
Output/Output	functional insulation, rated insulation voltage 50 V AC
Directive conformity	
Electromagnetic compatibility	
Directive 2004/108/EC	EN 61326-1:2006
Conformity	
Electromagnetic compatibility	NE 21:2006
Protection degree	IEC 60529
Ambient conditions	
Ambient temperature	-20 ... 60 °C (-4 ... 140 °F)
Mechanical specifications	
Protection degree	IP20
Mass	approx. 200 g
Dimensions	20 x 124 x 115 mm (0.8 x 4.9 x 4.5 in) , housing type B2
General information	
Supplementary information	Statement of Conformity, Declaration of Conformity, Attestation of Conformity and instructions have to be observed where applicable. For information see www.pepperl-fuchs.com .

Accessories

Power feed module KFD2-EB2

The power feed module is used to supply the devices with 24 V DC via the Power Rail. The fuse-protected power feed module can supply up to 100 individual devices depending on the power consumption of the devices. A galvanically isolated mechanical contact uses the Power Rail to transmit collective error messages.

Power Rail UPR-03

The Power Rail UPR-03 is a complete unit consisting of the electrical inset and an aluminium profile rail 35 mm x 15 mm. To make electrical contact, the devices are simply engaged.

Profile Rail K-DUCT with Power Rail

The profile rail K-DUCT is an aluminum profile rail with Power Rail insert and two integral cable ducts for system and field cables. Due to this assembly no additional cable guides are necessary.



Power Rail and Profile Rail must not be fed via the device terminals of the individual devices!