



Model Number

MLE76000-54-G/25/110/115/123

Retroreflective sensor
with fixed cable

Features

- EHEDG-certified sensors with hygienic design
- Stainless steel version, especially suitable for applications in the food industry
- Integrated mounting solution is part of the EHEDG certificate
- Pressure fitted front panel without the use of adhesives
- Reliable and leak-proof housing, even with repeated thermal shocks

Product information

The EHEDG certificate of compliance for the MLE76 series confirms that this sensor system is easy to clean and ensures a high degree of microbiological safety. This is possible through the integration of various mounting adapters in the overall sensor concept and through the adaptation of all sensor properties to the strict hygiene requirements in the product-contact area. All sensor materials are non-toxic, non-absorbent and highly resistant to corrosion. The rounded stainless steel housing plus mounting adapters have no edges and therefore allow more efficient cleaning without dismantling the sensor.

Dimensions

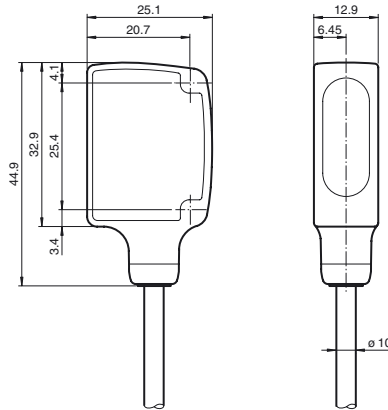

Electrical connection

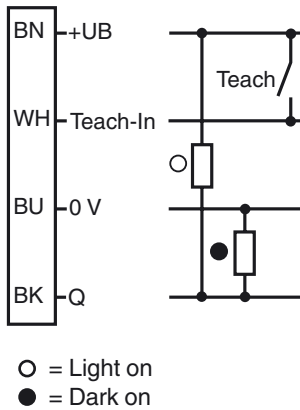

Indicators/operating means

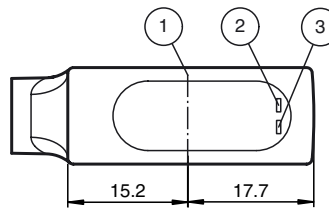

1	Optical axis	
2	Operating display	green
3	Signal display	yellow

Release date: 2011-08-22 15:09 Date of issue: 2011-08-22 22:44:27_eng.xml

Subject to modifications without notice

Pepperl+Fuchs Group
www.pepperl-fuchs.com

USA: +1 330 486 0001
fa-info@us.pepperl-fuchs.com

Germany: +49 621 776-4411
fa-info@pepperl-fuchs.com

Copyright Pepperl+Fuchs
Singapore: +65 6779 9091
fa-info@sg.pepperl-fuchs.com

Technical data**General specifications**

Effective detection range	0 ... 3.2 m in TEACH mode 0 ... 4 m by operating mode "N"
Reflector distance	0 ... 3.2 m in TEACH mode 0 ... 4 m by operating mode "N"
Threshold detection range	5.1 m
Reference target	H85-2 reflector
Light source	LED
Light type	modulated visible red light , 660 nm
Angle deviation	max. $\pm 1^\circ$
Diameter of the light spot	approx. 40 mm at detection range 1 m
Angle of divergence	1.7 °
Ambient light limit	40000 Lux

Indicators/operating means

Operating display	LED green, statically lit Power on , Undervoltage indicator: Green LED, pulsing (approx. 0.8 Hz) , short-circuit : LED green flashing (approx. 4 Hz)
Function display	LED yellow: switching state ; Stability control ; Teach-In
Controls	none
Contrast detection levels	10 % - clean, water filled PET bottles 18 % - clear glass bottles 40 % - colored glass or opaque materials adjustable by external TEACH-IN switch

Electrical specifications

Operating voltage	U_B	10 ... 30 V DC
Ripple		max. 10 %
No-load supply current	I_0	< 20 mA at 24 V DC

Input

Function input	Ext. Teach-In input (ET)
----------------	--------------------------

Output

Switching type	light on	
Signal output	1 push-pull output, short-circuit protected, reverse polarity protected	
Switching voltage	max. 30 V DC	
Switching current	max. 100 mA	
Switching frequency	f	1 kHz
Response time	500 μ s	

Ambient conditions

Ambient temperature	-20 ... 60 °C (-4 ... 140 °F)
Storage temperature	-40 ... 75 °C (-40 ... 167 °F)

Mechanical specifications

Protection degree	IP67 / IP69K
Connection	2 m fixed cable
Material	
Housing	Stainless steel 1.4404 / AISI 316L
Optical face	PMMA
Mass	80 g

Compliance with standards and directives

Standard conformity	
Product standard	EN 60947-5-2:2007

Approvals and certificates

UL approval	cULus
CCC approval	Products with a maximum operating voltage of ≤ 36 V do not bear a CCC marking because they do not require approval.

Curves/Diagrams

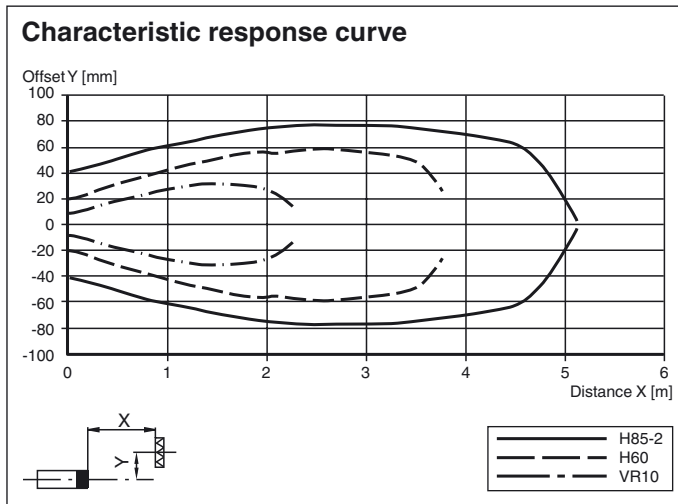

Curves/Diagrams

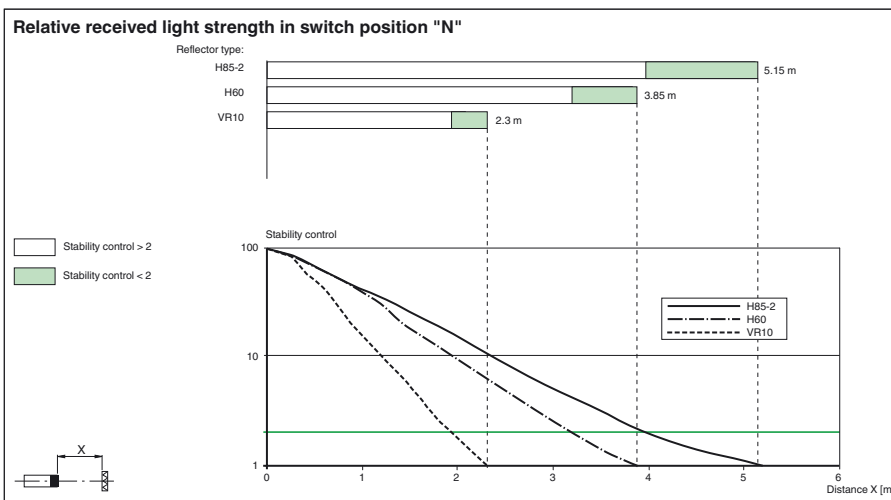
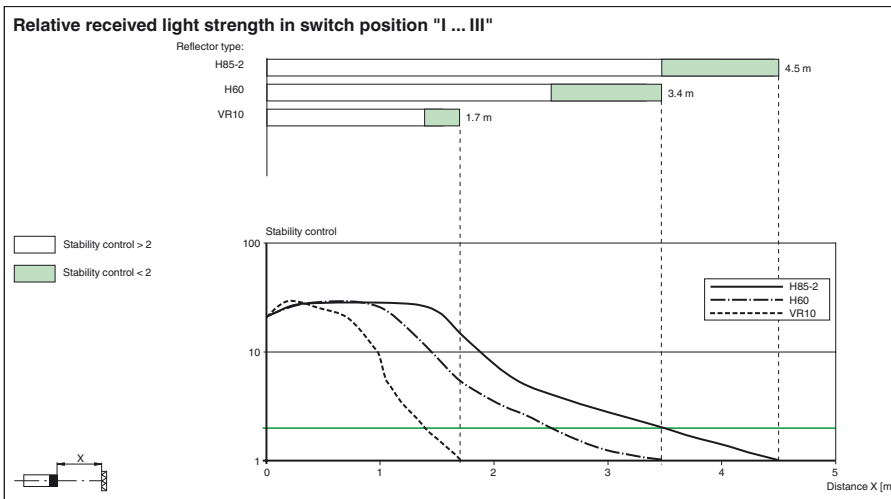

Additional information

Ext. TEACH input:

It is possible to trigger a TEACH-IN process and to select the operating mode by the external connecting of a High pulse of a certain width:

- I: 50 ms (30 ms - 80 ms)
- II: 150 ms (120 ms - 180 ms)
- III: 250 ms (220 ms - 280 ms)
- N: 350 ms (320 ms - 380 ms)

Release date: 2011-08-22 15:09 Date of issue: 2011-08-22 22:4427_eng.xml

Instructions for the TEACH-IN mode:

Operating mode	LED green	LED yellow	Time/ Frequency	Explanations/ Remarks
Teach-In	flashes	flashes	2/s	Slow equiphase flashing: TEACH-IN process is being executed. Max. duration of the TEACH-IN process: 2 s
	off	on	250 ms	TEACH-IN process correctly finished. Operating mode is changed.
	flashes	flashes	8/s	Rapid alternating flashing: TEACH-IN process not correctly executed.(e.g. receiver signal not sufficient, sensor not correctly aligned with reflector) Status is terminated by turning switch to position N.
N	on	flashes	4/s	In operating mode "N" aligned with reflector. Reflector detected without functional reserve.
	on	on	-	In operating mode "N" aligned with reflector. Reflector detected with functional reserve (recommended).
I	on	on	-	Contrast detection 10 % is activated. (e.g. clean PET bottles filled with water)
II	on	on	-	Contrast detection 18 % is activated. (e.g. bottles made of clear glass)
III	on	on	-	Contrast detection 40 % is activated. (e.g. tinted glass or intransparent materials)