

Termination Board

HiDTB08-TRI-DIISQ-EL-SC

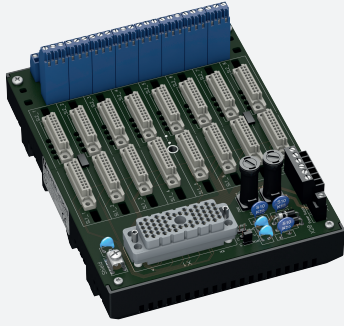

- System board for Schneider Electric, Tricon series by Triconex
- TAN48 approval
- For 64-channel (32+32) DI card 3564
- For 8 modules
- Recommended modules: HiD2824 (DI), HiD2844 (DI)
- 24 V DC supply
- Hazardous area: screw terminals, blue
- Non-hazardous area: ELCO socket, 56-pin



Function

The function of the termination board and the connector pinout is exactly fitted to the requirements of Triconex system. The termination board has a fault bus (Fault) that is available at the redundant terminals. Power supply faults and module faults are indicated via this fault bus. The fault signals of several termination boards can be connected together and can be monitored by an optional fault indication board. The fault signals are then available to the control system as a volt-free contact. The termination board is supplied with a robust plastic housing. This design permits the fast and reliable installation on 35 mm DIN mounting rail according to EN 60715 in the switch cabinet.

Application

- Triconex card Tricon:
- Termination board 1 and cable 1: channel 1 to 32
 - Termination board 2 and cable 2: channel 33 to 64

Connection

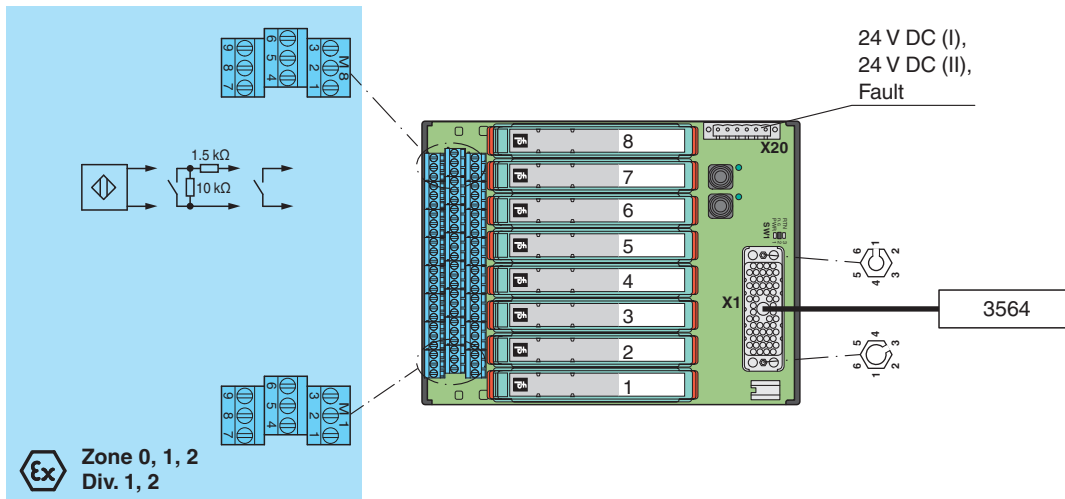

Technical Data

Supply	
Connection	X20: terminals 3, 5(+); 4, 6(-)
Nominal voltage	24 V DC , in consideration of rated voltage of used isolators
Voltage drop	0.9 V , voltage drop across the series diode on the termination board must be considered
Ripple	≤ 10 %
Fusing	2 A , in each case for 8 modules

Release date: 2023-02-20 Date of issue: 2023-02-20 Filename: 227881_eng.pdf

Refer to "General Notes Relating to Pepperl+Fuchs Product Information".

Pepperl+Fuchs Group
www.pepperl-fuchs.com

USA: +1 330 486 0002
pa-info@us.pepperl-fuchs.com

Germany: +49 621 776 2222
pa-info@de.pepperl-fuchs.com

Singapore: +65 6779 9091
pa-info@sg.pepperl-fuchs.com

PEPPERL+FUCHS

Technical Data

Power dissipation	≤ 500 mW , without modules
Reverse polarity protection	yes
Redundancy	
Supply	Redundancy available. The supply for the isolators is decoupled, monitored and fused.
Fault indication output	
Connection	fault bus (Fault) : X20: terminals 1, 2
Output type	volt-free contact
Switch behaviour	fault bus (Fault) - no fault: relay contact of the fault indication board closed - power supply fault: relay contact of the fault indication board open - module fault: relay contact of the fault indication board open
Contact loading	fault bus (Fault) : 30 V DC , 1 A , see fault indication board
Indicators/settings	
Display elements	LED PWR1 (termination board power supply), green LED LED PWR2 (termination board power supply), green LED
Configuration	jumper SW1: card selection - position 1: DI card 3564 - position 2: n.c. (factory setting) - position 3: DI card 3504E
Directive conformity	
Electromagnetic compatibility	
Directive 2014/30/EU	EN 61326-1:2013 (industrial locations)
Conformity	
Electromagnetic compatibility	
	NE 21:2017 For further information see system description.
Degree of protection	IEC 60529:2001
Ambient conditions	
Ambient temperature	-20 ... 60 °C (-4 ... 140 °F)
Storage temperature	-40 ... 70 °C (-40 ... 158 °F)
Mechanical specifications	
Degree of protection	IP20
Connection	
Field side	explosion hazardous area: screw terminals , blue
Control side	non-explosion hazardous area: ELCO socket, 56-pin
Supply	pluggable screw terminals , black
Fault output	pluggable screw terminals , black
Core cross section	screw terminals: 0.2 ... 2.5 mm ² (24 ... 12 AWG)
Material	housing: polycarbonate, 10 % glass fiber reinforced
Mass	approx. 550 g
Dimensions	150 x 200 x 163 mm (5.9 x 7.9 x 6.42 inch) (W x H x D) , depth including module assembly
Mounting	on 35 mm DIN mounting rail acc. to EN 60715:2001
Data for application in connection with hazardous areas	
EU-type examination certificate	CESI 11 ATEX 062
Marking	⊕ II (1)G [Ex ia Ga] IIC ⊕ II (1)D [Ex ia Da] IIIC ⊕ I (M1) [Ex ia Ma] I
Non-hazardous area	
Maximum safe voltage	250 V (Attention! U _m is no rated voltage.)
Galvanic isolation	
Field circuit/control circuit	safe electrical isolation acc. to IEC/EN 60079-11, voltage peak value 375 V
Directive conformity	
Directive 2014/34/EU	EN IEC 60079-0:2018+AC:2020 , EN 60079-11:2012 , EN 50303:2000
International approvals	
CSA approval	
Control drawing	see control drawing of corresponding modules

Release date: 2023-02-20 Date of issue: 2023-02-20 Filename: 227881_eng.pdf

Technical Data

IECEX approval	
IECEX certificate	IECEX CES 11.0022
IECEX marking	[Ex ia Ga] IIC [Ex ia Da] IIC [Ex ia Ma] I
General information	
Supplementary information	Observe the certificates, declarations of conformity, instruction manuals, and manuals where applicable. For information see www.pepperl-fuchs.com .

Accessories

	HiALC-HIDTB-SET-150	Label carrier for HiD termination boards
---	----------------------------	--

Release date: 2023-02-20 Date of issue: 2023-02-20 Filename: 227881_eng.pdf

Refer to "General Notes Relating to Pepperl+Fuchs Product Information".

Pepperl+Fuchs Group
www.pepperl-fuchs.com

USA: +1 330 486 0002
pa-info@us.pepperl-fuchs.com

Germany: +49 621 776 2222
pa-info@de.pepperl-fuchs.com

Singapore: +65 6779 9091
pa-info@sg.pepperl-fuchs.com

Application

Typical circuit

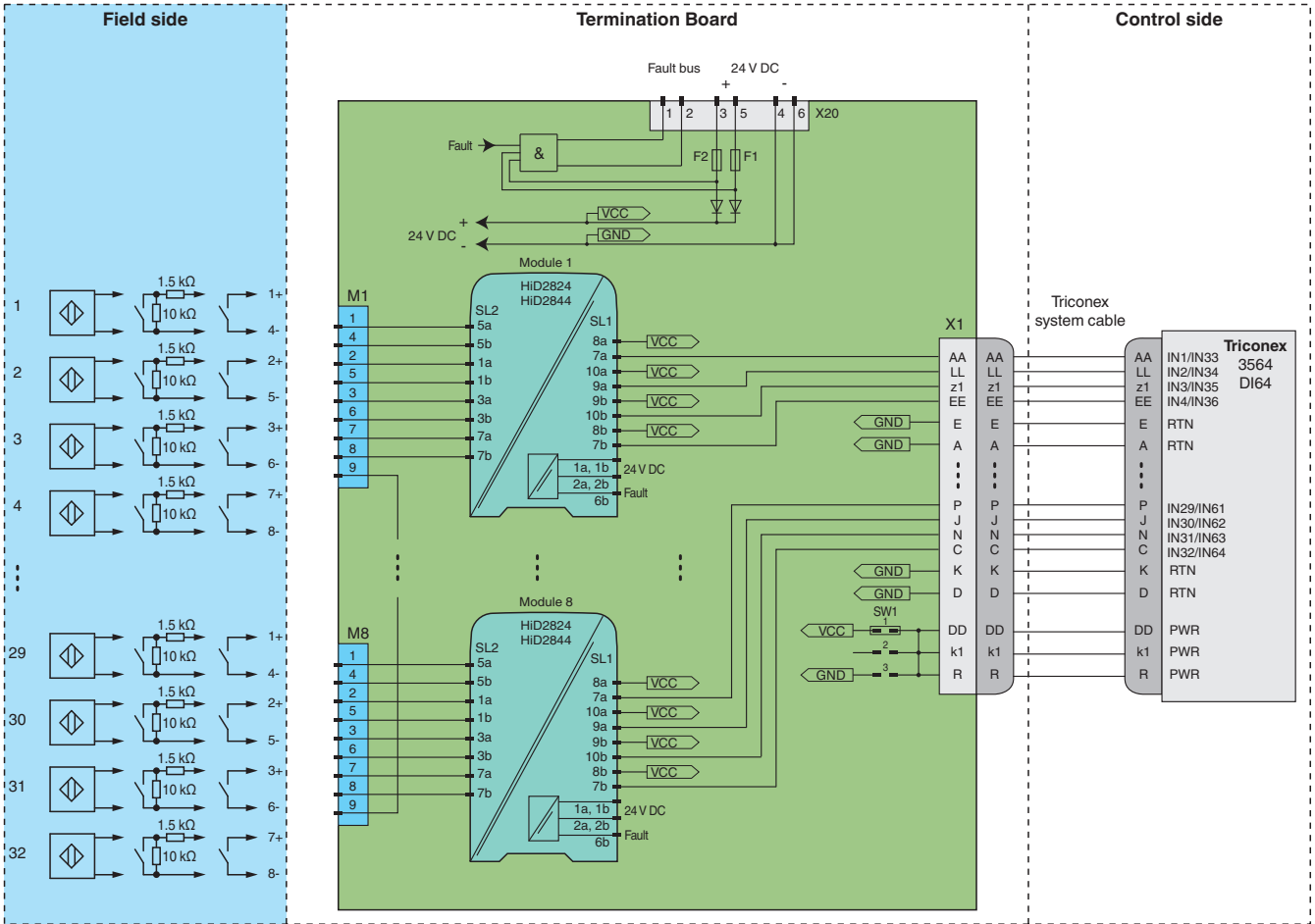

Termination board configuration

Jumper SW1	Position	Card selection
	1	DI card 3564
	2	n.c. (factory setting)
	3	DI card 3504E

Module switch settings

Type (DI)	Channel	DIP switch	Position
HiD2824, HiD2844 • Mode of operation: close – energized open – de-energized • Input line fault detection: enabled	1	S1	OFF
		S2	ON
	2	S3	OFF
		S4	ON
	3	S5	OFF
		S6	ON
	4	S7	OFF
		S8	ON



For exact pin assignment for connection to field side and control side, see the documentation of the isolated barrier.



The pin-out configuration has to be observed. For information see corresponding pin-out table on www.pepperl-fuchs.com.

Release date: 2023-02-20 Date of issue: 2023-02-20 Filename: 227881_eng.pdf